

EFA-SST® TK-100: Braves the frost

With its unique EFA-AFM® technology providing a practically hermetic seal, coupled with an elaborate heater design the EFA-SST® TK-100 provides constant warmth to the structure and blade of the door, avoiding the accumulation of condensation or ice. EFAFLEX's unique construction method makes this door solution suitable for installation outside and inside the freezer area at temperatures down to -30 °C.

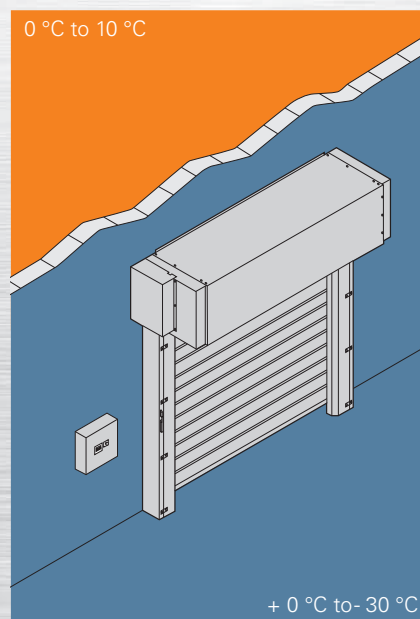
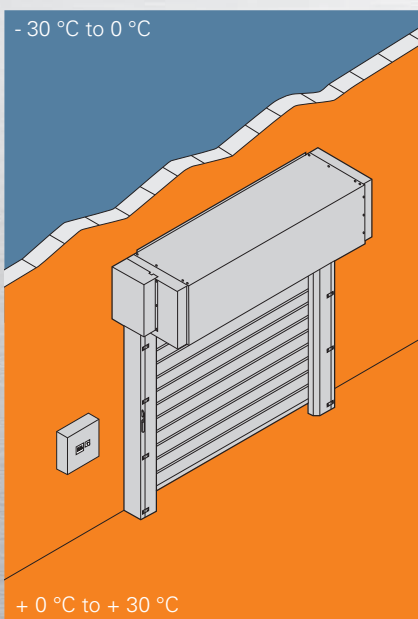

Spiral design

- Extremely fast and quiet operation due to our spiral construction
- Designed to minimise contact, reducing abrasion to the door blade
- Unique EFA-AFM® sealing technology

Door blade

- Thermally separated and insulated EFA-THERM® laths as standard
- Minimising energy costs with U values up to 0.62 W/m²K (depending on door size)
- Elaborate heating system between the laths and around the door blade

Control EFA-TRONIC®

- Externally mounted steel control box
- With integrated frequency converter

Finish

- Galvanised, stainless steel or powder coating acc. to RAL

Safety

- Infra-red light curtain (TLG) combined with heated contact edge
- Optional 2 photo cells combined with heated contact edge

Emergency operation

- Manual opening utilizing spring tension

Speed / Cycles

- Opening speed up to 2.0 m/s (depending on door size)
- Up to 200.000 operating cycles per year

General

- Max. sizes W 4,500 mm x H = 6,000 mm
- Wind class 4
- Air permeability class 5 according to DIN EN 12426
- Tested and certified by ift institute