

961

962



This technical product description
applies to the following door system types:

EFA-SST®-L Classic

EFA-SST®-S Classic

EFA-SST®-ÜS Classic

EFA-STT®-L

EFA-STT®-S

EFA-STT®-ÜS

EFAFLEX Tor- und Sicherheitssysteme GmbH & Co. KG

Fliederstraße 14

84079 Bruckberg

GERMANY

Telephone: +49 8765 82-0

Fax: +49 8765 82-200

Email: info@efaflex.com

Internet: www.efaflex.com

Translation of the original

Version 03-EN

30.03.2021

© EFAFLEX Tor- und Sicherheitssysteme GmbH & Co. KG

Door system designations

Official designation of the door system	Spiral type	Designation of the door system in this product description
EFA-SST®-L Classic	Round spiral	237 R
	Oval spiral	237 O
	Low lintel	243 N
EFA-SST®-S Classic	Round spiral	238 R
	Oval spiral	238 O
	Low lintel	236 N
EFA-SST®-ÜS Classic	Round spiral	235 R
	Oval spiral	235 O
EFA-STT®-L	Round spiral	231 R
	Low lintel	272 N
EFA-STT®-S	Round spiral	232 R
EFA-STT®-ÜS	Round spiral	247 R

Table of contents

1	Short description.....	5
2	Technical properties.....	6
3	Construction of the high-speed spiral door.....	16
4	Door safety.....	36
5	Equipment.....	39
6	Packaging units.....	40

1 Short description

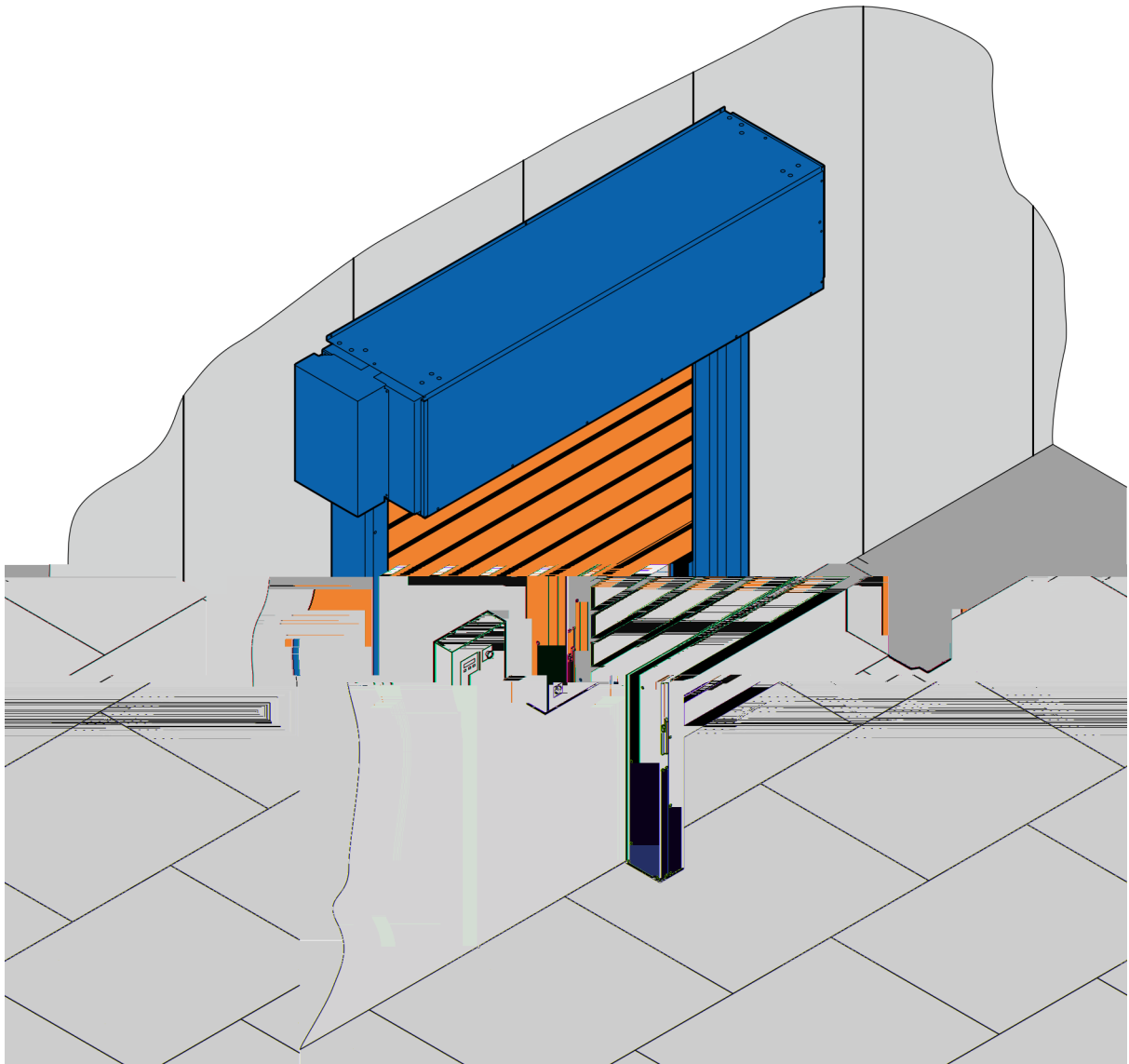

Fig. 1: High-speed spiral door

S series high-speed spiral doors and high-speed turbo doors are door systems designed for industrial and commercial purposes. The basic construction is based on tried and tested spiral door technology.

The door leaf for the EFA-SST® Classic is equipped with 20, 30 and 40 mm thick, double-walled, aluminium extrusion-press laths with a spacing of 151 mm.

The door leaf for the EFA-STT® is equipped with 30, 40 and 60 mm thick, aluminium extrusion-press profiles and a pressure-grouted, single-wall filling with a spacing of 225 mm.

2 Technical properties

Use

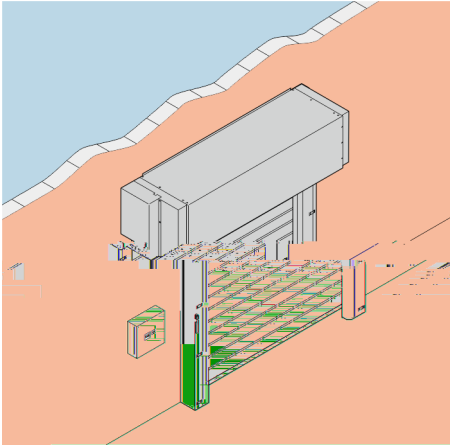

Fig. 2: Use

Use

- Industrial door
- Hall door
- Outdoor installation under a canopy provided by the owner possible

	Outdoor (-15 °C to +50 °C)
	Indoor (+5 °C to +50 °C)

The control cabinet must be installed in an ambient temperature of > +5 °C.

Dimensions 237 R, 237 O

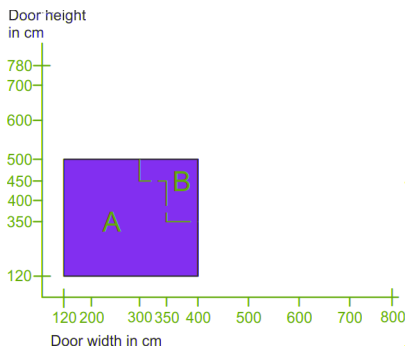

Fig. 3: Diagram of possible door system heights and door system widths

There are two different structural designs of the side frames for the door system type 237.

In door area “A”, the side frame depth of both side frames is 235 mm – 2 springs can be used on the left and on the right in this area.

In door area “B”, the side frame depth of both side frames is 285 mm – up to 3 springs can be used on the left and on the right in this area.

Door system heights and widths (inner clear height)

Door system type	Widths	Heights
237 R; 237 O	1200 – 4000 mm	1200 – 5000 mm

Dimensions 243 N

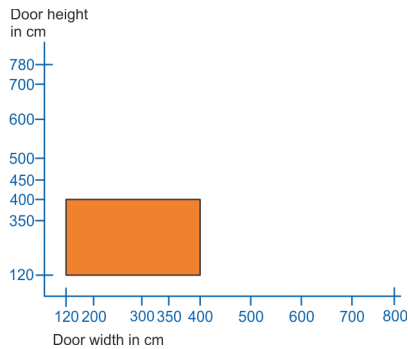

Fig. 4: Diagram of possible door system heights and door system widths

Door system heights and widths (inner clear height)

Door system type	Widths	Heights
243 N	1200 – 4000 mm	1200 – 4000 mm

Dimensions 238 R, 238 O

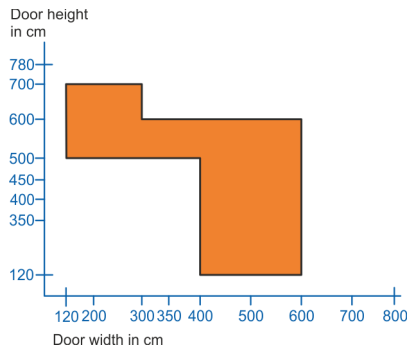

Fig. 5: Diagram of possible door system heights and door system widths

Door system heights and widths (inner clear height)

Door system type	Widths	Heights
238 R; 238 O	1200 – 3000 mm	5000 – 7000 mm
	3001 – 4000 mm	5000 – 6000 mm
	4001 – 6000 mm	1200 – 6000 mm

Dimensions 236 N

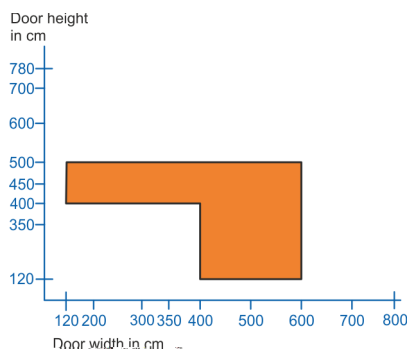

Fig. 6: Diagram of possible door system heights and door system widths

Door system heights and widths (inner clear height)

Door system type	Widths	Heights
236 N	1200 – 4000 mm	4000 – 5000 mm
	4001 – 6000 mm	1200 – 5000 mm

Technical properties

Dimensions 235 R

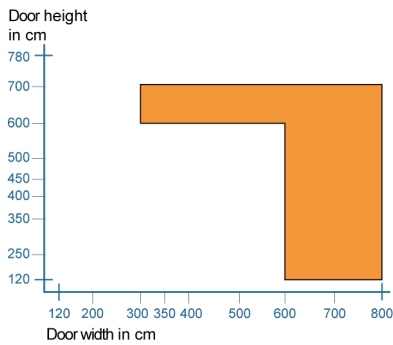

Fig. 7: Diagram of possible door system heights and door system widths

Door system heights and widths (inner clear height)

Door system type	Widths	Heights
235 R	3000 – 6000 mm	6000 – 7000 mm
	6001 – 8000 mm	1200 – 7000 mm

Dimensions 235 O

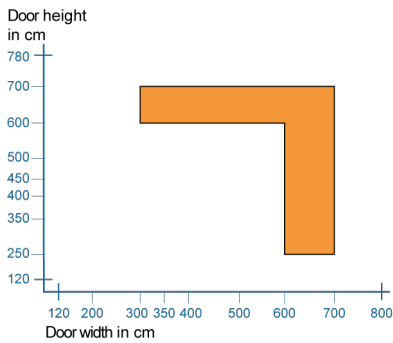

Fig. 8: Diagram of possible door system heights and door system widths

Door system heights and widths (inner clear height)

Door system type	Widths	Heights
235 O	3000 – 6000 mm	6000 – 7000 mm
	6001 – 7000 mm	2500 – 7000 mm

Dimensions 231 R

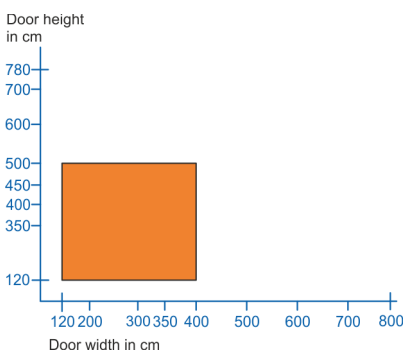

Fig. 9: Diagram of possible door system heights and door system widths

Door system heights and widths (inner clear height)

Door system type	Widths	Heights
231 R	1200 – 4000 mm	1200 – 5000 mm

Dimensions 272 N

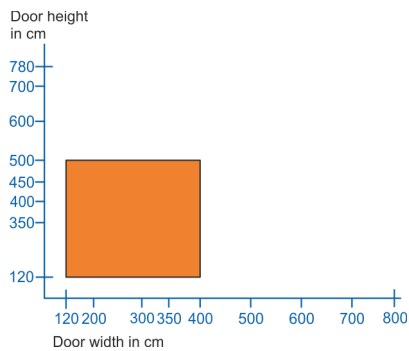

Fig. 10: Diagram of possible door system heights and door system widths

Door system heights and widths (inner clear height)

Door system type	Widths	Heights
272 N	1200 – 4000 mm	1200 – 5000 mm

Dimensions 232 R

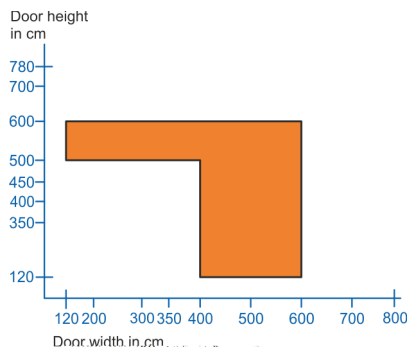

Fig. 11: Diagram of possible door system heights and door system widths

Door system heights and widths (inner clear height)

Door system type	Widths	Heights
232 R	1200 – 4000 mm	5000 – 6000 mm
	4001 – 6000 mm	1200 – 6000 mm

Dimensions 247 R

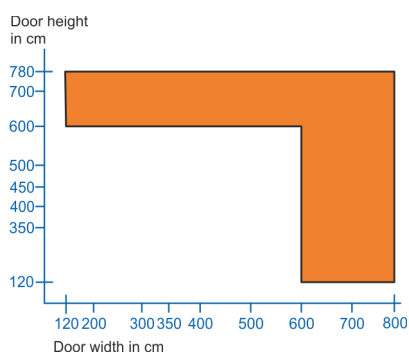

Fig. 12: Diagram of possible door system heights and door system widths

Door system heights and widths (inner clear height)

Door system type	Widths	Heights
247 R	1200 – 6000 mm	6000 – 7800 mm
	6001 – 8000 mm	1200 – 7800 mm

Technical properties

Speeds

Door system type	Average speed (max. speed)		
	Opening speed	Closing speed with door light grid	Closing speed with safety edge and light barrier
237 R, O	1.5 m/s (2.0 m/s)	1.0 m/s	0.75 m/s
243 N	1.0 m/s (1.5 m/s)	1.0 m/s	0.75 m/s
238 R, O	1.2 m/s (2.0 m/s)	1.0 m/s	0.6 m/s
236 N	1.2 m/s (1.5 m/s)	1.0 m/s	0.6 m/s
235 R, O	1.0 m/s (1.5 m/s)	1.0 m/s	0.6 m/s
231 R	2.5 m/s (3.0 m/s)	1.0 m/s	0.75 m/s
272 N	1.5 m/s (1.8 m/s)	1.0 m/s	0.75 m/s
232 R	2.2 m/s (2.8 m/s)	0.6 m/s	0.6 m/s
247 R	1.8 m/s (2.0 m/s)	0.6 m/s	0.6 m/s

Speeds depend on the height of the door system

Performance properties as per DIN EN 13241

Door system type	Indication	Door system width/size, other information	Value	
			237	243
237 R 237 O 243 N	Resistance to wind load as per DIN EN 12424	1200 mm ≤ B ≤ 3100 mm	Class 4	Class 4
		3100 mm < B ≤ 3500 mm	Class 3	Class 3
		3500 mm < B ≤ 4000 mm	Class 2	Class 2
	Resistance to water penetration as per DIN EN 12425	-	Class 0	npd
	Air permeability as per DIN EN 12426	-	Class 2	npd
	Airborne sound insulation as per DIN EN ISO 717-1	for standard aluminium lath	Rw = 23 dB	Rw = 23 dB
Thermal insulation as per DIN EN 12428	for standard aluminium lath			
	for 4000 × 4000 mm	-	U = 5.80 W/m²K	
	for 4000 × 5000 mm	U = 5.80 W/m²K	-	

npd = no performance determined

Technical properties

Door system type	Indication	Door system width/size, other information	Value	
			238	236
238 R 238 O 236 N	Resistance to wind load as per DIN EN 12424	1200 mm ≤ B ≤ 6000 mm	Class 4	Class 4
	Resistance to water penetration as per DIN EN 12425	-	Class 0	npd
	Air permeability as per DIN EN 12426	-	Class 2	npd
	Airborne sound insulation as per DIN EN ISO 717-1	for standard aluminium lath	Rw = 25 dB	Rw = 25 dB
	Thermal insulation as per DIN EN 12428	for 6000 × 5000 mm	-	U = 5.70 W/m²K
		for 6000 × 6000 mm	U = 5.60 W/m²K	-

npd = no performance determined

Door system type	Indication	Door system width/size, other information	Value
235 R	Resistance to wind load as per DIN EN 12424	1200 mm ≤ B ≤ 6000 mm	Class 4
		6000 mm < B ≤ 7000 mm	Class 3
		7000 mm < B ≤ 8000 mm	Class 2
	Resistance to water penetration as per DIN EN 12425	-	Class 0
	Air permeability as per DIN EN 12426	-	Class 2
	Airborne sound insulation as per DIN EN ISO 717-1	for standard aluminium lath	Rw = 25 dB
	Thermal insulation as per DIN EN 12428	for standard aluminium lath for 8000 × 7000 mm	U = 5.60 W/m²K

Technical properties

Door system type	Indication	Door system width/size, other information	Value
235 O	Resistance to wind load as per DIN EN 12424	$1200 \text{ mm} \leq B \leq 6000 \text{ mm}$	Class 4
		$6000 \text{ mm} < B \leq 7000 \text{ mm}$	Class 3
		$7000 \text{ mm} < B \leq 8000 \text{ mm}$	Class 2
	Resistance to water penetration as per DIN EN 12425	-	Class 0
	Air permeability as per DIN EN 12426	-	Class 2
	Airborne sound insulation as per DIN EN ISO 717-1	for standard aluminium lath	Rw = 25 dB
Thermal insulation as per DIN EN 12428	for standard aluminium lath for $7000 \times 7000 \text{ mm}$	U = 5.60 W/m ² K	

Door system type	Indication	Door system width/size, other information	Value	
			231	272
231 R 272 N	Resistance to wind load as per DIN EN 12424	$1200 \text{ mm} \leq B \leq 3500 \text{ mm}$	Class 4	Class 4
		$3500 \text{ mm} < B \leq 4000 \text{ mm}$	Class 3	Class 3
	Resistance to water penetration as per DIN EN 12425	-	Class 0	npd
	Air permeability as per DIN EN 12426	-	Class 2	npd
	Airborne sound insulation as per DIN EN ISO 717-1	-	Rw = 20 dB	Rw = 20 dB
Thermal insulation as per DIN EN 12428	for $4000 \times 5000 \text{ mm}$	U = 6.50 W/m ² K	U = 6.50 W/m ² K	

npd = no performance determined

Technical properties

Door system type	Specification	Door system width/size, other specifications	Value
232 R	Resistance to wind load in compliance with DIN EN 12424	$1200 \text{ mm} \leq B \leq 4600 \text{ mm}$	Class 4
		$4600 \text{ mm} < B \leq 5200 \text{ mm}$	Class 3
		$5200 \text{ mm} < B \leq 6000 \text{ mm}$	Class 2
	Resistance to water penetration in compliance with DIN EN 12425	-	Class 0
	Air permeability in compliance with DIN EN 12426	-	Class 2
	Airborne sound insulation in compliance with DIN EN ISO 717-1	-	Rw = 20 dB
Thermal insulation in compliance with DIN EN 12428	for $6000 \times 6000 \text{ mm}$	U = 6.30 W/m ² K	

Door system type	Specification	Door system width/size, other specifications	Value
247 R	Resistance to wind load in compliance with DIN EN 12424	$1200 \text{ mm} \leq B \leq 6000 \text{ mm}$	Class 4
		$6000 \text{ mm} < B \leq 7000 \text{ mm}$	Class 3
		$7000 \text{ mm} < B \leq 8000 \text{ mm}$	Class 2
	Resistance to water penetration in compliance with DIN EN 12425	-	Class 0
	Air permeability in compliance with DIN EN 12426	-	Class 2
	Airborne sound insulation in compliance with DIN EN ISO 717-1	-	Rw = 20 dB
Thermal insulation in compliance with DIN EN 12428	for $8000 \times 7800 \text{ mm}$	U = 6.20 W/m ² K	

Fire performance as per DIN 4102

Indication	Value
Material class	B2 normally inflammable

Technical properties

Applicable regulation, safety standards and directives

The following regulation, standards and directives were taken into account in planning, engineering and production:

Regulation

EUV 305/2011	Regulation (EU) No 305/2011 of the European Parliament and of the Council of 9 March 2011 laying down harmonised conditions for the marketing of construction products and repealing Council Directive 89/106/EEC
--------------	---

Directives

2006/42/EC	DIRECTIVE 2006/42/EC OF THE EUROPEAN PARLIAMENT AND COUNCIL of 17 May 2006 on machinery, and amending Directive 95/16/EC
2014/30/EU	DIRECTIVE 2014/30/EU OF THE EUROPEAN PARLIAMENT AND COUNCIL of 26 February 2014 on harmonisation of the laws of the member states relating to electromagnetic compatibility
2014/35/EU	DIRECTIVE 2014/35/EU of the European Parliament and Council of 26 February 2014 on harmonisation of the laws of the member states relating to the making available on the market of electrical equipment designed for use within certain voltage limits

Standards

DIN EN 13241	Doors – Product standard, performance characteristics
DIN EN ISO 13849-1	Safety of machinery – Safety-related parts of control systems – Part 1 General principles for design
DIN EN ISO 13849-2	Safety of machinery – Safety-related parts of control systems – Part 2 Validation
DIN EN ISO 12100	Safety of machinery – General principles for design – Risk assessment and risk reduction

Door system type (SST)	Load cycles per year	Life cycle
237 R; 237 O	250,000	10 years
238 R; 238 O		
235 R; 235 O		

Door system type (SST)	Load cycles per year	Life cycle
243 N	150,000	10 years
236 N		

3 Construction of the high-speed spiral door

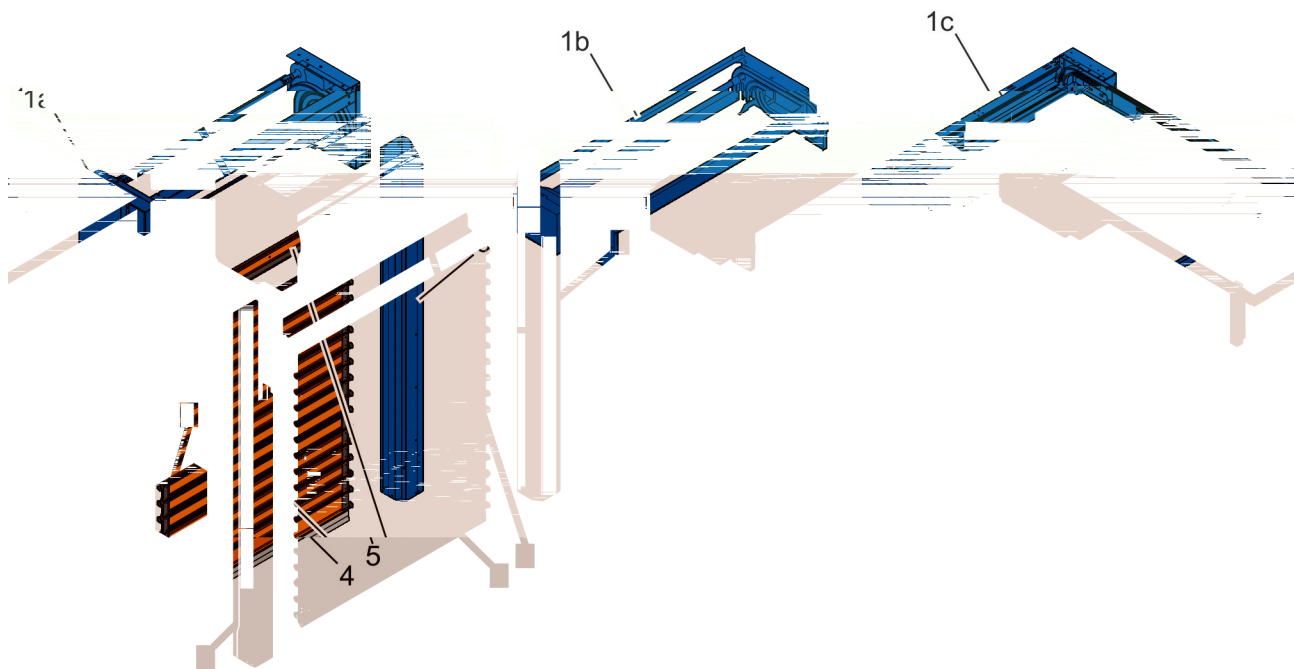

Fig. 13: Assemblies

1	Spiral case round (item 1a), oval (item 1b) or low (item 1c) with main support, spiral guide, motor, drive shaft, bearing, reinforcement profiles, cover (optional)	<ul style="list-style-type: none"> ↳ “Spiral case versions” starting on page 17 ↳ “Overview of drives”, starting on page 31 ↳ “Cover versions” on page 19
2	Control unit	↳ “Overview of the controls”, starting on page 32
3	Side frames with vertical door leaf guide, tooth belt for door leaf, weight counterbalance and door light grid	<ul style="list-style-type: none"> ↳ “Door leaf guide, side frame and optional pivoting side frame cover” on page 25 ↳ ‘Transmission of force’ on page 21 ↳ ‘Weight counterbalance’ on page 22 ↳ “Door light grid” starting on page 36
4	Door leaf	↳ ‘Door leaf’ on page 26
	Laths	↳ “Overview of laths”, starting on page 27
	Safety edge	↳ “Safety edge and light barrier” starting on page 37
5	Horizontal seal	↳ ‘Seal’ on page 30

Spiral case

The spiral case is available in "round", "oval" and "low" versions.

The spiral case comprises:

- Synchronous shaft with bearing (item 1)
- Bevelled main supports with spiral guide on both sides (item 2)
- Sheet metal reinforcement profiles (item 3)

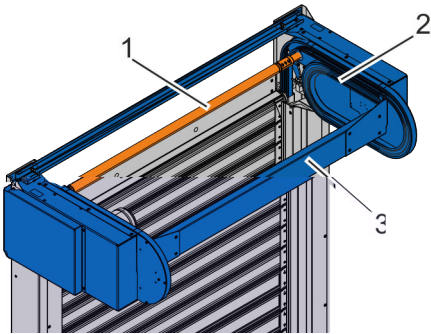

Fig. 14: Oval spiral case

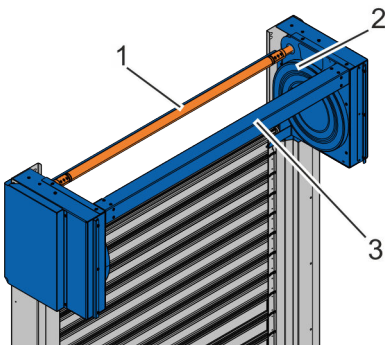

Fig. 15: Round spiral case

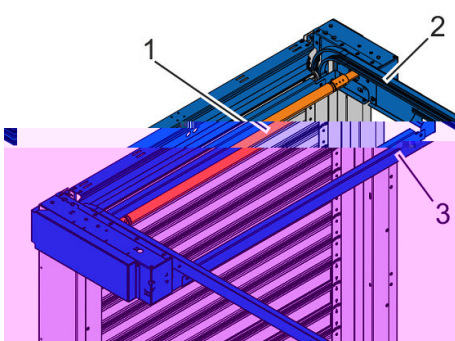

Fig. 16: Low spiral case

The size of the horizontal door leaf guide for doors with a low lintel design depends on the clearance height of the door system. As can be seen from the quotation drawings for low lintel doors (in this case dimension "f", Fig. 17), the size of the horizontal door leaf guide increases at door heights of ≤ 2300 mm by the clearance of 500 mm.

This prevents a possible crush hazard for the body and/or parts of the body and meets the requirements of DIN EN 12453.

Construction of the high-speed spiral door

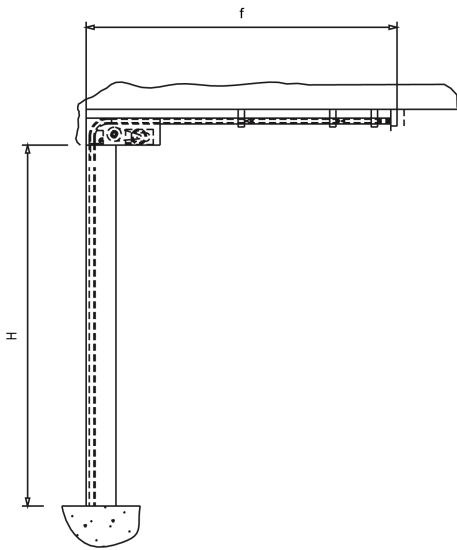

Fig. 17: Low lintel door drawing

Spiral case cover (optional)

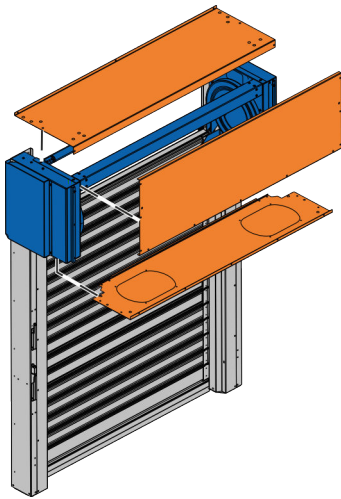

Fig. 18: Round spiral case cover

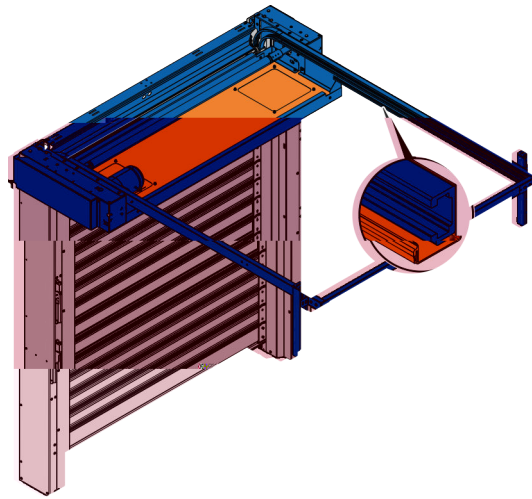

Fig. 19: Low lintel spiral case cover

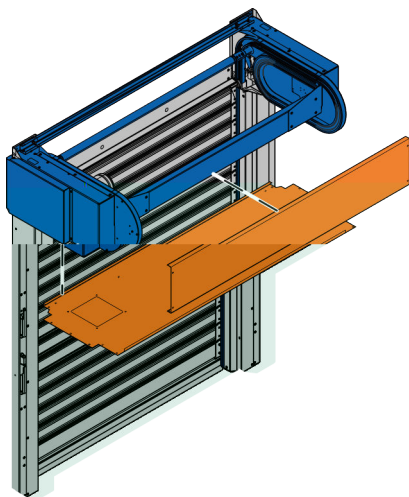

Fig. 20: Oval spiral case cover



Depending on the door system, the sheet metal profiles are equipped with inspection openings, which can be opened for maintenance purposes if necessary.

The cover for the low lintel and the round spiral design has two inspection openings.

The cover for the oval spiral has one inspection opening on the motor side.

Irrespective of the design, type 235 and 247 door systems do not have any inspection openings.

The spiral case can optionally be covered at the bottom, front and top. The covers may reduce the clear height.

Covers on the front and bottom are only possible in combination. The top cover is only possible if the front and bottom are also covered. On door systems with an oval spiral, the cover on the top is not possible. On door systems with a low lintel design, the bottom cover also covers the front cover up to the maximum possible coverable area of the spiral case. A further cover is not possible on low lintel door systems.



The spiral case cover to prevent access is mandatory for door systems with a height of less than 2500 mm or 2300 mm with low lintel.

Construction of the high-speed spiral door

Door system type	Sheet metalprofile			Hinged side frame cover
	bottom + front	top	Restriction of clear height	
237 R	available	available	35 mm*	available
237 O	up to H = 3000 mm	-	35 mm	available
243 N	available	-	none	available
238 R	available	available	35 mm	available
238 O	up to B ≤ 4500 mm and H ≤ 4000 mm	-	55 mm	available
236 N	available	-	none	available
235 R	available	available	40 mm	•
235 O	-	-	-	•
231 R	available	available	35 mm*	available
272 N	available	-	none	available
232 R	available	available	35	available
247 R	available	available	50 mm	•

• Standard

- not available

* Restriction does not apply to H ≤ 3000 mm (237 R) or H ≤ 2900 mm (231 R)

Transmission of force

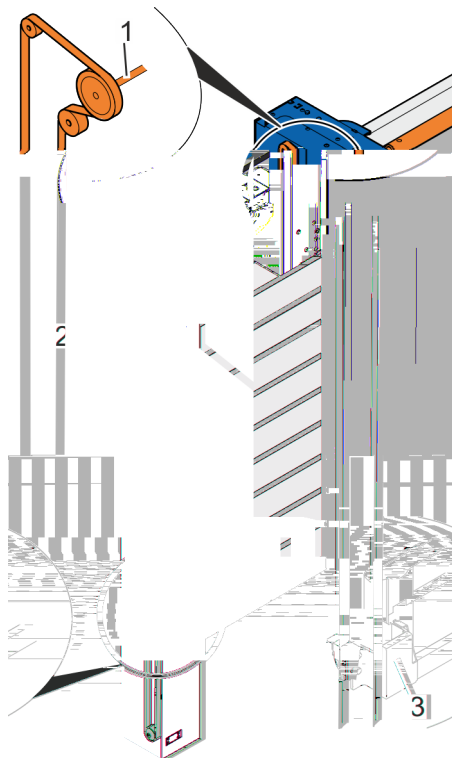

Fig. 21: Low lintel transmission of force

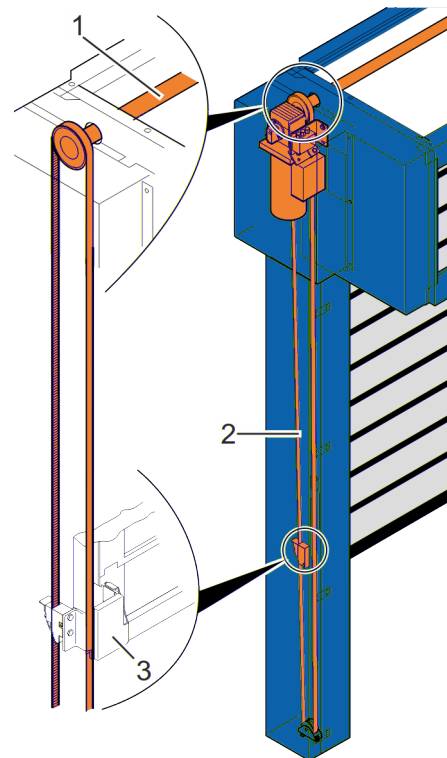

Fig. 22: Round and oval spiral transmission of force

The transmission of force from the drive to the door leaf is performed by the synchronous shaft (Fig. 21/1 and Fig. 22/1), the continuous toothed belt (Fig. 21/2 and Fig. 22/2) and the door leaf mounts (Fig. 21/3 and Fig. 22/3). Unlike a chain, the toothed belt runs very quietly.

The door leaf mounts are situated on the right and left-hand sides of the door leaf and are screwed to the hinge chains and the lowest lath of the door leaf (bottom lath). The hinge chains on both sides of the door system connect the bottom lath to the other laths. When the door leaf moves, the force is only applied to the bottom lath. All the other laths are fastened to the hinge chain and are moved at the same time without the effect of force.

Construction of the high-speed spiral door

Weight counterbalance

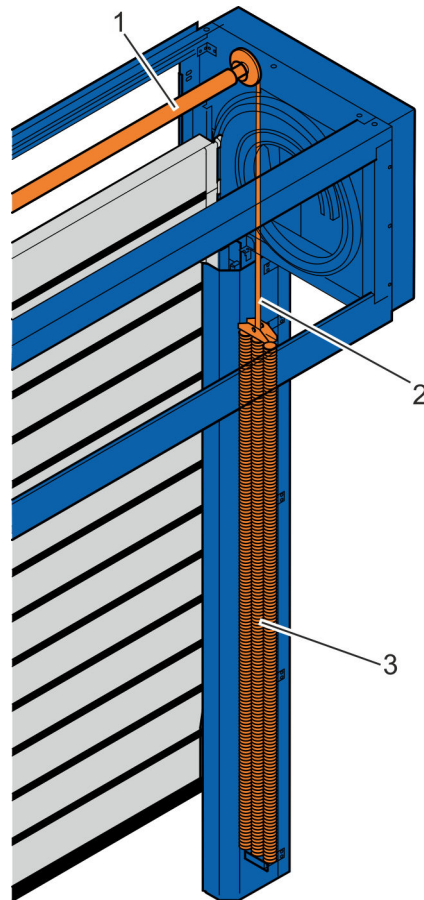

Fig. 23: Weight counterbalance

The door leaf weight counterbalance is a back pull mechanism: Tension springs (Fig. 23/3) are installed in the side frames. The tension springs are connected to the synchronous shaft (Fig. 23/1) by heavy-duty belts (Fig. 23/2). The tension springs are tensioned when the door system is closed and relaxed when the door system is open.

This way the door system can also be opened by hand (without electrical power) in case of emergencies. In normal mode the engine is assisted by the force of the tension springs.

The spring tension is calculated for each individual door.

Manual release lever



Fig. 24: Manual release lever on the side frame (left) and on a separate console (right)

The manual release lever is situated on the side frame or optionally on a separate console. When the lever is pulled gently, the motor brake is released and the door leaf is lifted by the spring counterbalance. The door system can be opened completely by pushing the door leaf upwards manually. The control unit is in EMERGENCY STOP status during this operation. The manual release lever is not designed for regular opening of the door system and does not have a catch position.

The manual release lever is also available in a lockable design (optional).

Door locking mechanism (optional)

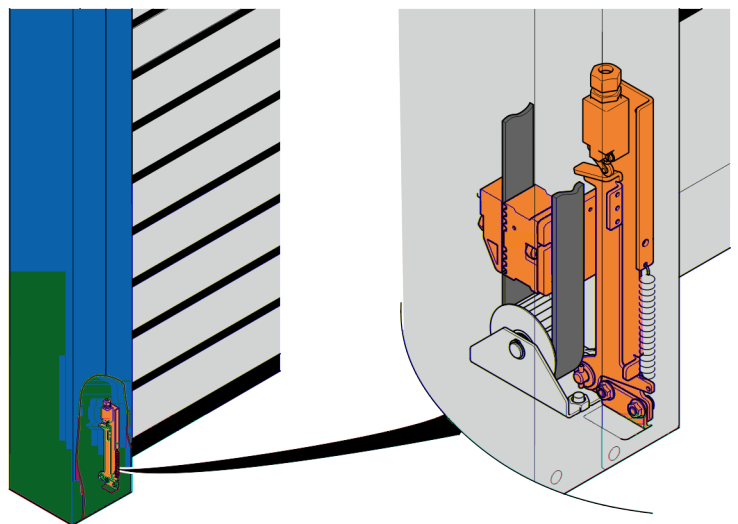
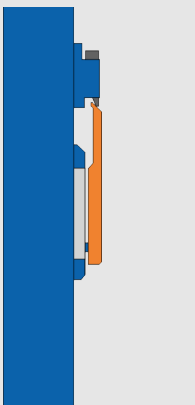
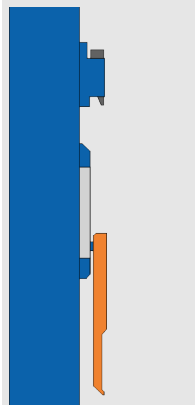
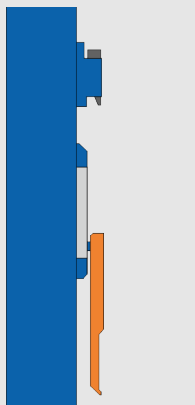
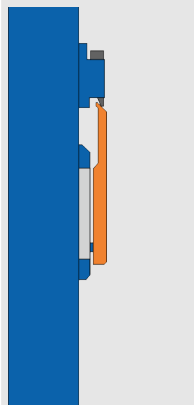
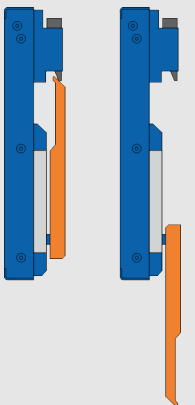

Fig. 25: Door locking mechanism

The mechanical locking mechanism is installed in the vertical side frame on the motor side. The locking mechanism handle keeps the door leaf closed so that it is safe from break-ins. The door locking mechanism is operated using a lever which is fitted to the side frame or on an optional separate console.

Construction of the high-speed spiral door

The following versions are possible:

Standard version: Lever fitted to side frame		Optionally: Lever fitted to the side frame with reversed lever position		Optionally: Lever fitted to a separate console
Door leaf not locked	Door leaf locked	Door leaf not locked	Door leaf locked	
				
Lever position: Lever up	Lever position: Lever down	Lever position: Lever down	Lever position: Lever up	The lever position depends on laying of Bowden cable
Optional locking version			Optional locking version	Lever position up, optional locking version

Door leaf guide, side frame and optional pivoting side frame cover

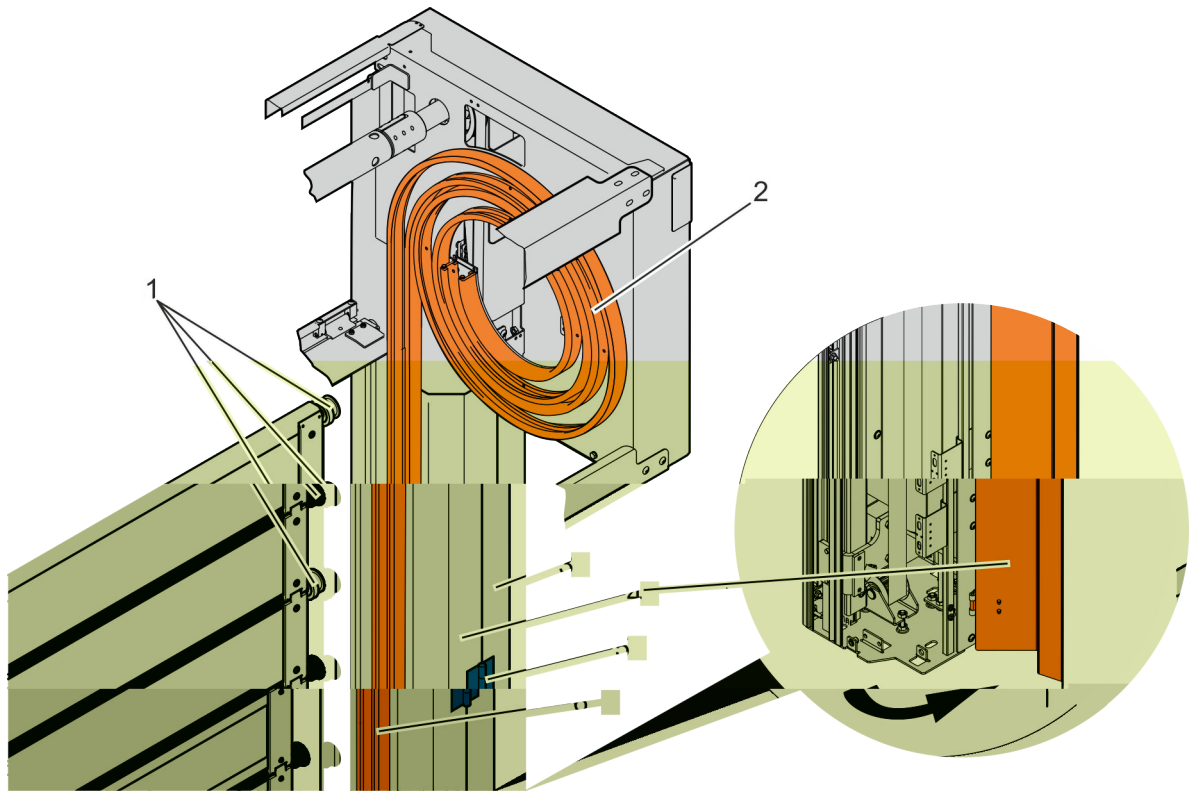

Fig. 26: Door leaf guide

The door leaf comprises laths which are connected by a hinge chain. Rollers (Fig. 26/1) are attached to the hinge chain. When the door system is opened and closed, the rollers are directed through the vertical (Fig. 26/6) and spiral-shaped (Fig. 26/2) door leaf guide. The rolling of the rollers in the door leaf guide only generates very low noise. The roller friction also makes for minimum wear on the rollers as no soiling is generated from abrasion. There is no wear on the door leaf itself. This gives the door system a long service life.

The vertical door leaf guides (Fig. 26/6) are made of sheet metal and aluminium profiles and are situated within the side frames (Fig. 26/3). Each side frame is made up of one main bevelled sheet metal profile and one bevelled sheet metal cover profile (Fig. 26/4). The sheet metal cover profiles are fastened with screws. Optionally, they can also be supplied in a pivoting design with hinges (Fig. 26/5).

For more information about this door-specific design option, see [☞ "Spiral case cover \(optional\)" on page 20.](#)

Construction of the high-speed spiral door

Door leaf

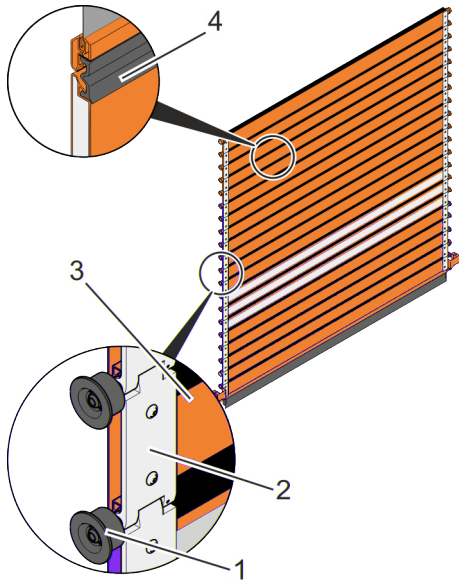

Fig. 27: Door leaf with 20 mm thick EFA-ALUX® aluminium laths and a spacing of 151 mm (AST)

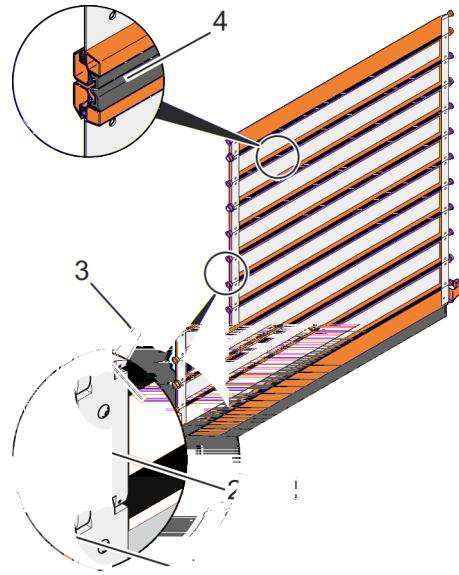

Fig. 28: Door leaf with 30 mm thick EFA-CLEAR® sight laths and a spacing of 225 mm (LKZ)

The door leaf is made up of laths (Fig. 27/3 and Fig. 28/3), which are held at the correct spacing by hinge chains (Fig. 27/2 and Fig. 28/2). This spacing prevents contact between the laths. They are thus free from wear. The forces for opening and closing the door system are transmitted via hinges.

Ball bearing mounted rollers (Fig. 27/1 and Fig. 28/1) keep the door firmly in the guides in the horizontal direction. The laths are connected to each other by rubber hinges (Fig. 27/4 and Fig. 28/4).

The door leaf is equipped with 20, 30 or 40 mm thick EFA-ALUX® aluminium laths with a spacing of 151 mm (AST) or with 30, 40 or 60 mm thick EFA-CLEAR® sight laths with a spacing of 225 mm (LKZ).

As equipment for the door leaf, 20 mm thick EFA-ALUX® aluminium laths (AST), EFA-CLEAR® sight laths (SAN or polycarbonate filling) and EFA-VENT® ventilation laths can be selected.

As an option, the 30 mm thick EFA-CLEAR® sight laths (LKZ) can also be fitted as EFA-VENT® ventilation laths with a polycarbonate or non-transparent SAN filling.

The tried and tested EFAFLEX door leaf design guarantees extremely quiet operation.

Construction of the high-speed spiral door

Laths and door leaf thicknesses

Door system type	EFA-ALUX® aluminium lath	EFA-CLEAR® sight lath single-walled	EFA-VENT® ventilation lath	Door leaf thickness
237 R	x	x	x	20 mm
237 O	x	x	x	
243 N	x	x	x	
238 R	x	x	x	30 mm
238 O	x	x	x	
236 N	x	x	x	
235 R	x	x*	x*	40 mm
235 O	x	x*	x*	
231 R	-	x	x	30 mm
272 N	-	x	x	
232 R	-	x	x	40 mm
247 R	-	x	x	60 mm

* Sight glass/ventilation lath screwed on

Calculation formula
Viewing strip width (235 R, 235 O)
EFA-CLEAR® sight lath

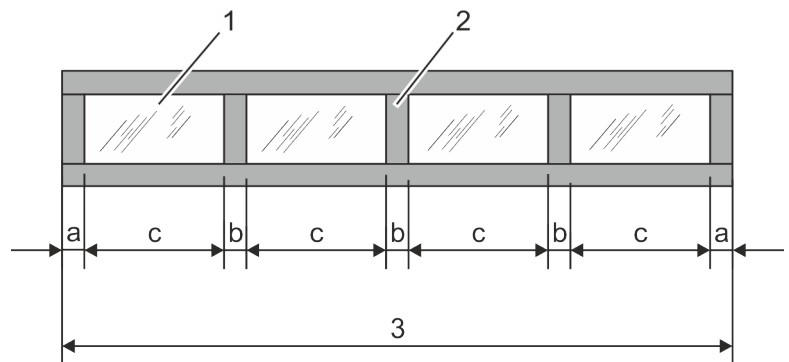

Fig. 29: Sketch of the calculation formula

- 1 Viewing strips, height approx. 82 mm
- 2 Middle bar
- 3 Light width
- a 90 mm
- b 100 mm
- c Dependent on the door width

$(B-575)/5$ for $B \leq 5000$ mm (5 viewing areas)

$(B-675)/6$ for $B > 5000$ mm (6 viewing areas)

Construction of the high-speed spiral door

EFA-ALUX® aluminium lath

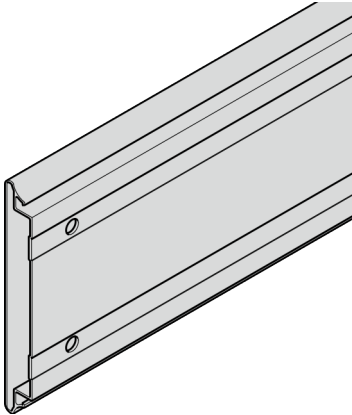

Fig. 30: EFA-ALUX® aluminium lath

The EFA-ALUX® aluminium lath comprises a double-walled anodised aluminium profile.

Dimensions	20/30/40 × 148 mm (AST)
Finish	E6/EV1 (natural anodised)
Optional	Powder coating for aluminium profiles Colours in compliance with SAP

EFA-CLEAR® single-walled transparent lath (option)

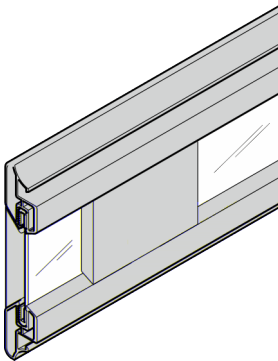

Fig. 31: EFA-CLEAR® transparent lath (single-walled)

The EFA-CLEAR® transparent lath is made up of transparent plastic panes pressed into the aluminium profiles.

Dimensions	20/30/40 × 148 mm (AST)
	30/40/60 × 222 (LKZ)
	Height of the viewing area:
	<ul style="list-style-type: none"> ■ approx. 82 mm (AST) ■ approx. 155 mm (LKZ) ■ approx. 136 mm (LKZ - 60 × 225)
Finish	E6/EV1 (natural anodised)
Glazing	SAN panes (transparent)
	SAN panes (non-transparent, coloured aluminium grey)
	Hard polycarbonate panes (scratch resistant) ⇒ Not for 40 × 148 mm (AST)
Optional	Powder coating for aluminium profiles Colours in compliance with SAP

The number of transparent laths is limited for AST.

EFA-VENT® ventilation lath (optional)

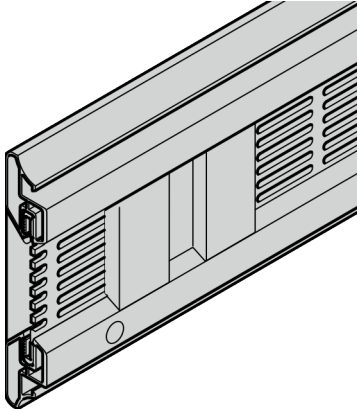

Fig. 32: EFA-VENT® ventilation lath

The EFA-VENT® ventilation lath comprises aluminium metal sheet with elongated holes (50 × 6 mm) which are pressed into the aluminium profiles.

Dimensions	20/30 × 148 mm (AST) 30/40/60 × 222 mm (LKZ)
Finish	E6/EV1 (natural anodised)
Vent cross section (except 235 R, 235 O)	$LA = ((B-0.180) \times 0.041) \times \text{number of laths (AST)}$ $LA = ((B-0.105) \times 0.066) \times \text{number of laths (LKZ)}$ B = door system width in metres
Vent cross section (235 R, 235 O)	B ≤ 5000 mm: $LA = ((B-0.575) \times 0.035) \times \text{laths}$ B > 5000 mm: $LA = ((B-0.675) \times 0.035) \times \text{laths}$
Optional	Powder coating for aluminium profiles and ventilation sheets Colours in compliance with SAP

The number of ventilation laths is limited for AST.

Construction of the high-speed spiral door

Seal

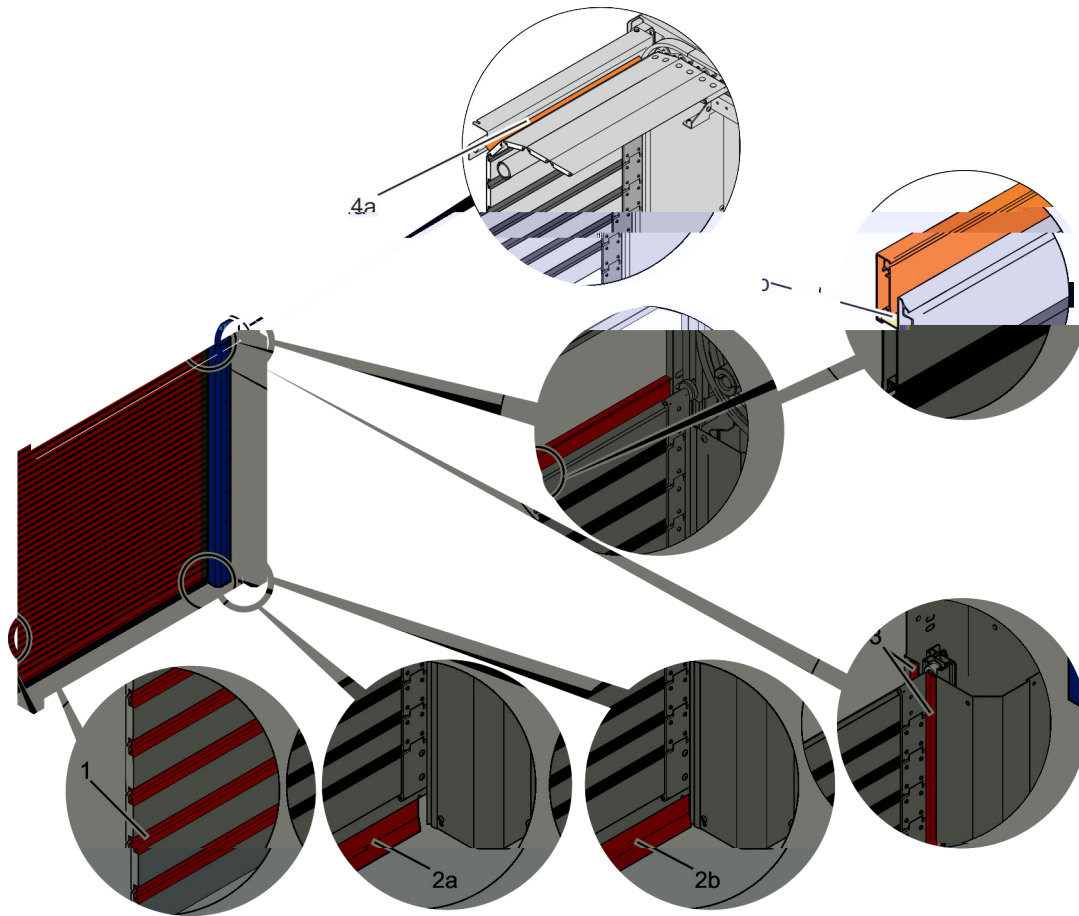

Fig. 33: Seal

The low-wear plastic door leaf seals (Fig. 33/3) provide the vertical sealing effect. The rubber profiles perform this function in the horizontal direction.

On the 237 R, 237 O, 243 N, 238 R, 238 O, 236 N, 231 R and 272 N door system types, the length of the rubber profile is B - 15 mm for design reasons (Fig. 33/2a). On all other door system types with this product description, the rubber profile protrudes as far as the side frame on the left and right (Fig. 33/2b). The laths are sealed off by rubber hinges, one below the other (Fig. 33/1).

A sealing profile, mounted between the consoles or on the lintel, seals off the top of the door system. The top of the door system is also sealed by additional profiles with a rubber lip, which are fastened to the top 1 - 3 laths depending on the size and type of door system. If the door system is closed, the rubber lip seals off the sealing profile (Fig. 33/4a, 4b).

On door systems with a round or oval spiral, the sealing profile is made of aluminium and seals off on the rubber profile of the top lath. The height of the sealing profile is determined by the door leaf height, i.e. the door system height and lath spacing.

Construction of the high-speed spiral door

Drive

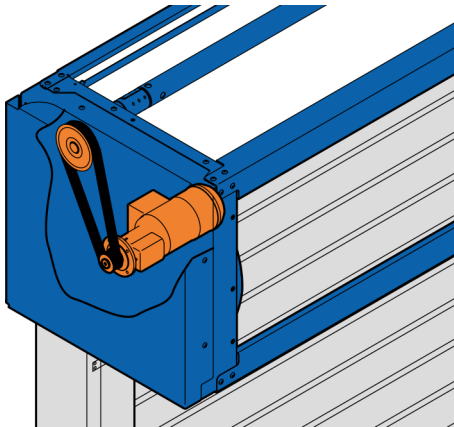

Fig. 34: Drive for door system types 237 R; 237 O; 243 N; 238 R; 238 O; 236 N; 231 R; 272 N; 232 R

237 R; 237 O; 243 N;
238 R; 238 O; 236 N;
231 R; 272 N;
232 R

Drive type	Integrated into the spiral to save space; transmission of force via toothed belt (Spur gear, asynchronous AC motor)
Power classes	0.75 kW – 1.5 kW
Protection type	IP54
Position detection	Absolute encoder. Thus no reference run is required.

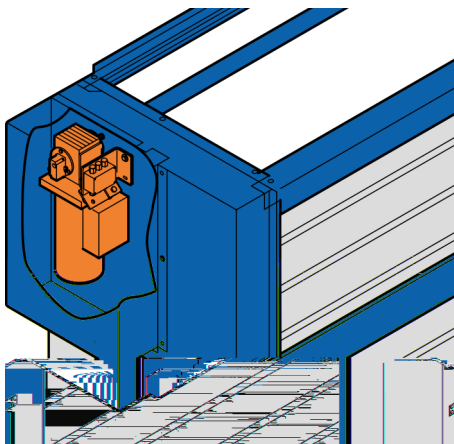

Fig. 35: Drive for door system types 235 R; 235 O; 247 R

235 R; 235 O;
247 R

Drive type	Direct mount drive (Spur gear, asynchronous AC motor)
Power classes	2.2 kW
Protection type	IP54
Position detection	Absolute encoder (thus no reference run is required). Optional incremental encoder.

Construction of the high-speed spiral door

Controls

Door system type	EFA-TRONIC®	EFA-TRONIC® Professional	Standard installation position
237 R	●	○	On the side, next to the side frame
237 O	●	○	
243 N	●	○	
238 R	●	○	
238 O	●	○	
236 N	●	○	
235 R	○	●	
235 O	○	●	
231 R	●	○	
272 N	●	○	
232 R	●	○	
247 R	○	●	

● Standard

○ Option

EFA-TRONIC® control

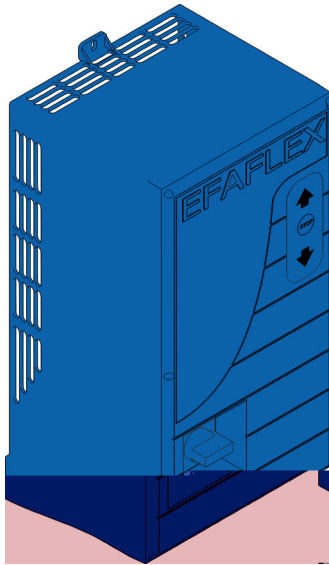

Fig. 36: EFA-TRONIC® control

Control	EFA-TRONIC® with frequency converter
Size (W × H × D)	210 × 400 (565)* × 200 mm (* incl. cable cover)
Housing	Polycarbonate housing
Protection type	IP65
Sight glass for display screen	Display of status messages and fault messages
Operating controls	Operating panel for operation and parametrisation of the door system Master switch
Supply voltage	L/N/PE 230 V ± 10 % or 3~L/N/PE 400 V ± 10 %
Frequency	50 – 60 Hz
Supply cable	Fuse protection of 16 A to be provided by the user (K characteristic)
With residual-current circuit breaker (RCCD) as necessary	300 mA as per DIN VDE 0100-530 (sensitive to universal current)

Construction of the high-speed spiral door

EFA-TRONIC® Professional

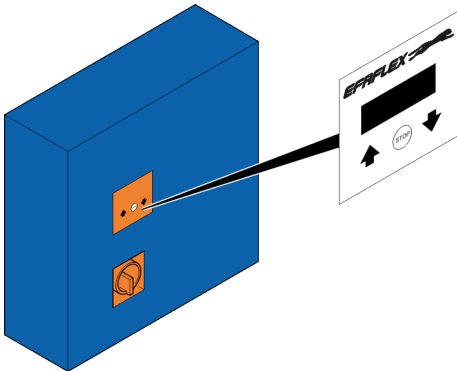
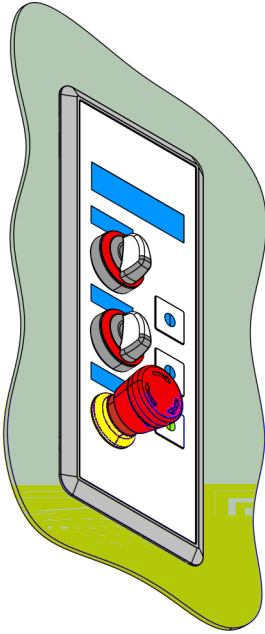

Fig. 37: EFA-TRONIC® Professional

Control unit	EFA-TRONIC® Professional with frequency converter
Size (W × H × D)	380 × 380 × 210 mm
Housing	Steel, colour RAL 7035 Optionally: <ul style="list-style-type: none"> ■ Painted RAL, colours in compliance with SAP ■ V2A
Protection type	IP54
Viewing window for display	Display of status messages and fault messages
Operating controls	Operating panel for operation and parametrisation of the door system Master switch
Supply voltage	L/N/PE 230 V ± 10 % or 3~L/N/PE 400 V ± 10 %
Frequency	50 – 60 Hz
Supply cable	Fuse protection of 16 A to be provided on-site (K characteristic)
With residual current device (RCCD) as necessary	300 mA in compliance with DIN VDE 0100-530 (sensitive to universal current)

EFA-HDI operating unit



As an enhancement of the EFA-TRONIC® Professional, an option to mount an additional operating unit on the wall is available. It is equipped with a display screen and offers full access to all parameters and all basic functions.

Fig. 38: EFA-HDI operating unit

Door safety

4 Door safety

Available door safety

Door system type	Safety edge and light barrier	Door light grid
237 R	●	○
237 O	●	○
243 N	●	○
231 R	●	○
272 N	●	○

Door system type	Door system width	Safety edge and light barrier	Door light grid
238 R; 238 O	≤ 5000 mm:	●	○
236 N	≤ 5000 mm:	●	○
235 R; 235 O	≤ 5000 mm:	●	○
232 R	≤ 5000 mm:	●	○
247 R	≤ 5000 mm:	●	○

Door system type	Door system width	Safety edge and light barrier	Door light grid
238 R; 238 O	> 5000 mm	○	●
232 R			
236 N	> 5000 mm	○	●
235 R; 235 O	> 5000 mm	○	●
247 R	> 5000 mm	○	●

● Standard

○ Optional



Simultaneous installation of a door light grid and light barrier(s) is not possible.

The main closing edge is secured by a combination of a safety edge and light barrier(s) (C device plus D device). This achieves the minimum protection level in line with DIN EN 12453.



In addition, the owner and the manufacturer have to consult with one another on providing protection for the approach area. This will be based on the owner's risk assessment.

Safety edge and light barrier

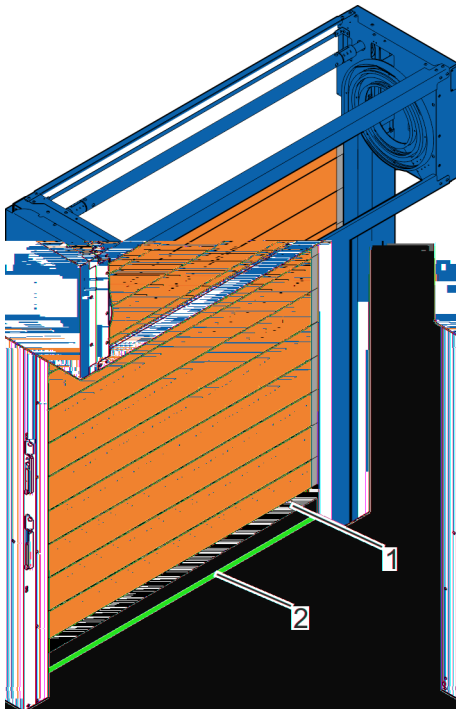

1	Safeguard for the closing edge	Safety edge
2	Light barrier (optional)	Unidirectional light barriers (IP67) max. 2

If the safety edge comes into contact with a person during the closing procedure, the door leaf stops, the door system opens completely and closes automatically again once the "keep-open" time has elapsed.

The light barriers, which are installed in the side frames at the sides, are offset from the door closing level. The height of the light barriers is variable.

Fig. 39: Safety edge and light barrier

Door light grid

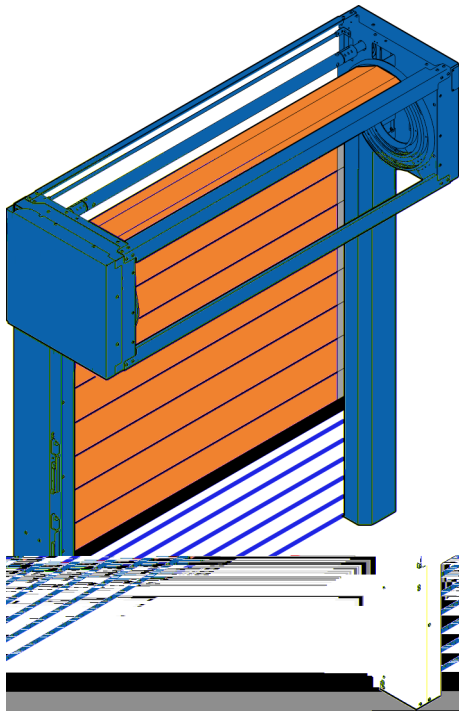

Fig. 40: Door light grid

The door light grid, which is installed in the side of the side frame, monitors the closing level, up to a height of 2.5 metres. The door light grid prevents the door system from closing when a person is detected in the danger area.

On door systems, an optional safety edge can be installed in addition to the door light grid. Simultaneous installation of a door light grid and light barrier is not possible.

5 Equipment

Possible equipment¹

- Galvanised basic door construction, 275 g/m²
- Basic door construction, galvanised (275 g/m²), with powder-coated finish in the colours as per SAP
 - Polyester based decorative powder coating
 - Coat thickness approx. 50 µm +/- 10 µm
 - Sheen level in compliance with DIN EN ISO 2813 (incidence angle 60°)
75 % ± 10 %
 - Smooth surface (no structure)
- Basic door construction stainless steel V2A 1.4301, corrosion resistant, polished grain 220
- EFA-ALUX[®] aluminium laths with a spacing of 151 mm (AST) or EFA-CLEAR[®] sight laths with a spacing of 225 mm (LKZ)
- EFA-CLEAR[®] sight lath
- EFA-VENT[®] ventilation lath
- Door leaf laths with powder-coated finish in the colours as per SAP
 - Polyester based decorative powder coating
 - Coat thickness approx. 50 µm +/- 10µm
 - Sheen level in compliance with DIN EN ISO 2813 (incidence angle 60°)
75 % ± 10 %
 - Smooth surface (no structure)
- EFA-TRONIC[®], EFA-TRONIC[®] Professional control
- Command devices: Push-buttons, pull switches, key switches, etc.
- Command devices/safety: Radar detector, EFA-SCAN[®], IR (infrared presence sensor)
- Door light grid of safety edge with up to two light barriers
- Spiral case covers
- Locking mechanism
- Locking mechanism which can be shut off
- Emergency operation device on side frame, not lockable
- Pivoting side frame cover (235 R and 247 R)
- Frame extension on both sides
- ““Door closed” limit switch, Schmersal roller lever switch type, Euchner CES safety limit switch, Pepperl + Fuchs NJ 15
- “Intermediate stop” limit switch, type Pepperl + Fuchs NJ 15
- “Door open” limit switch, Schmersal roller lever switch type
- EFA-HDI operating unit

¹ Depending on configuration

Special constructions

Special constructions/special orders are design types which are not covered, either mechanically or electrically, by standard versions in the sales price lists or by a design from the technology variants table. They have to be requested specifically. Surcharges and extended delivery times are calculated for special designs in accordance with the actual expenditure.

6 Packaging units

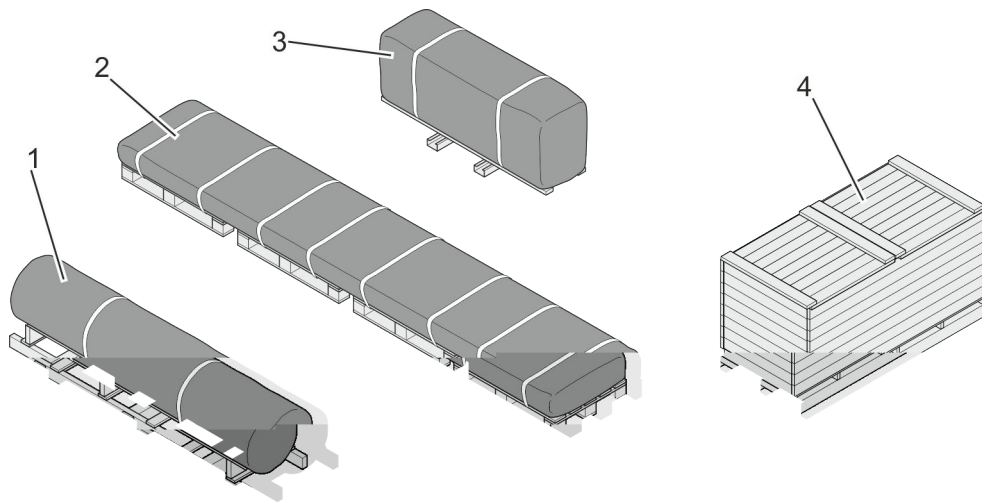

Fig. 41: Scope of delivery (left, standard transport unit), wooden crate (right, optionally for sea and fit-for-purpose* transport)



**Fit-for-purpose packaging is packaging which ensures that the packaged goods reach the recipient without damage, taking into account the shipping loads, shipping route, shipping duration and transportation load profile.*

Transport unit (example)

Transport unit 1: Door leaf package ("low lintel" version only)

Transport unit 2: Side frame sections with covers, control, accessories

Transport unit 3: Spiral case with door leaf, drive

Transport unit 4: Wooden crate (optional)

Number of transport units

The number of standard transport units depends on the selected number of door systems.

The door systems can also be delivered in a wooden crate. The number of wooden crates depends on the configuration of the door system types and the number of door systems.

The wood for the wooden crates optionally complies with the IPPC standard. For sea freight, the wooden crates are lined with film to protect them from moisture.

Packages which are fastened to pallets can be transported by fork lift under the following conditions:

- The fork lift must have the appropriate capacity for the weight of the packages.
- The package must be securely fastened to the pallet.
- The fork lift driver must be authorised to drive industrial trucks with a driver's seat or driver's station in accordance with the local regulations.

EFAFLEX



safe high speed drive