

TOR18

TOR19

Technical product description
High-speed spiral door
Efficient



For internal use only

Door system designations

Official designation of the door system	Spiral type	Designation of the door system in this product description

Table of contents

1	Short description	5
2	Technical properties	7
3	High-speed spiral door construction	10
4	Door safety	29
5	Equipment	30
6	Packaging units	31

1 Short description

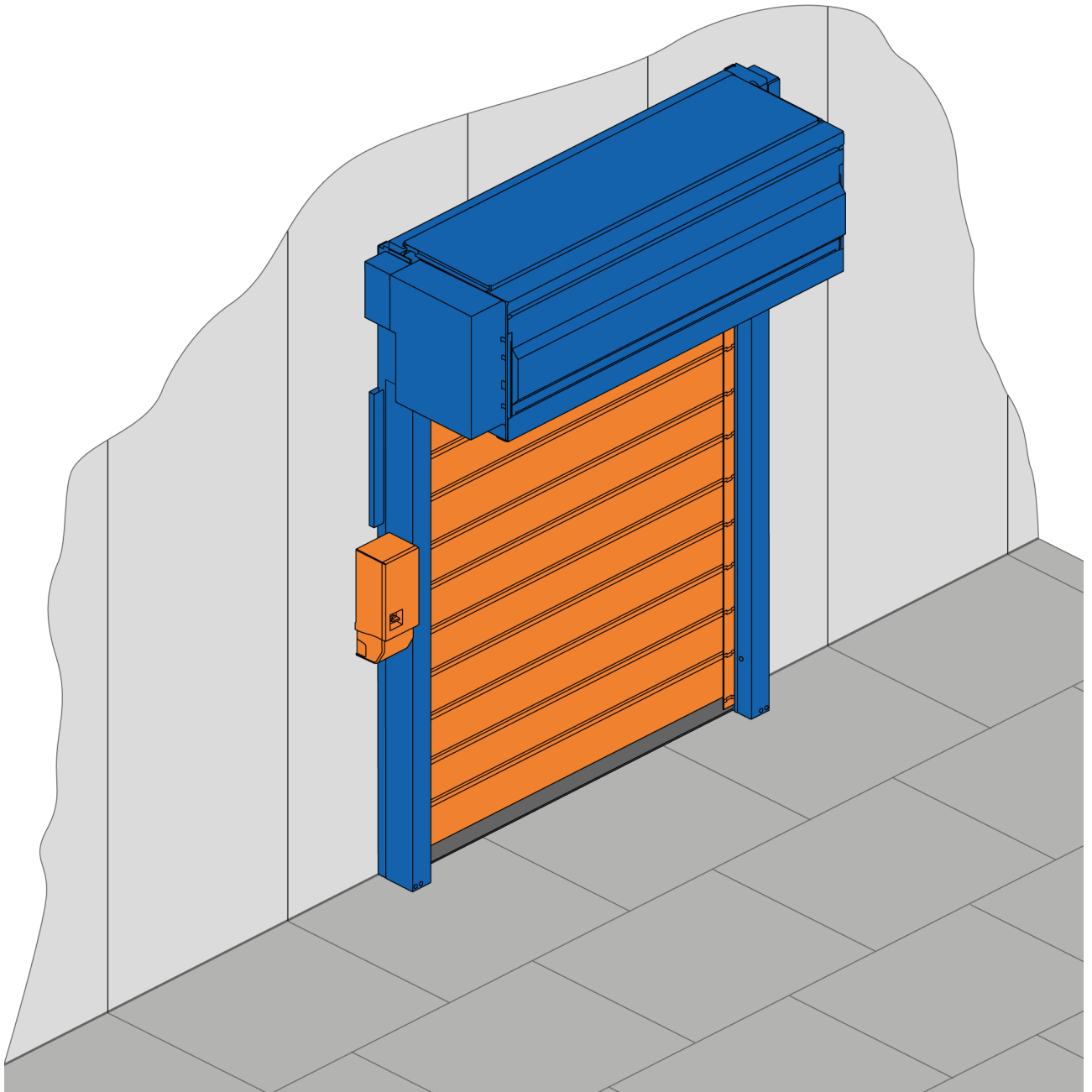

Fig. 1: High-speed spiral door

Short description

on page 25

↳ 'Drive'

-
-

%

2 Technical properties

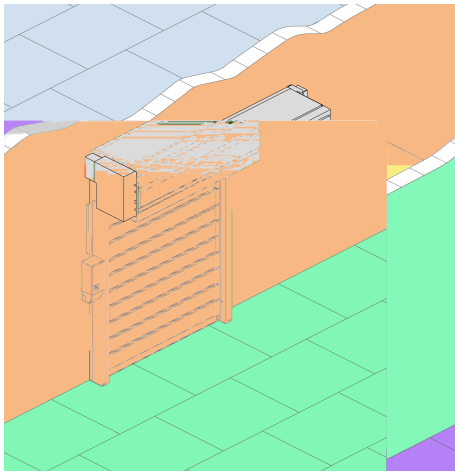

Fig. 2: Use



The control cabinet must be installed in an ambient temperature of $> +5\text{ }^{\circ}\text{C}$.

Dimensions

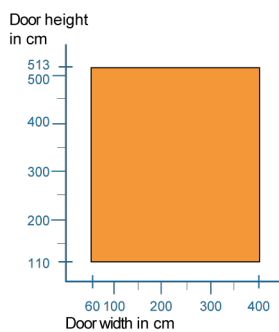

Fig. 3: Diagram of possible door system heights and door system widths

Door system heights and widths (inner clear height)

Door system type	Widths	Heights

Speeds

Door system type	Average speed	
	Opening speed	Closing speed with safety edge and light barrier

Technical properties

Performance properties in accordance with DIN EN 13241

Specification	Door system width/size/other specifications	Value
	≤ ≤	
	< ≤	
	< ≤	
	x	

Fire performance as per DIN 4102

Indication	Value

Performance

Door system type	Load cycles per year	Life cycle

Applicable regulation, safety standards and directives

Regulation

--	--

Directives

Standards

3 High-speed spiral door construction

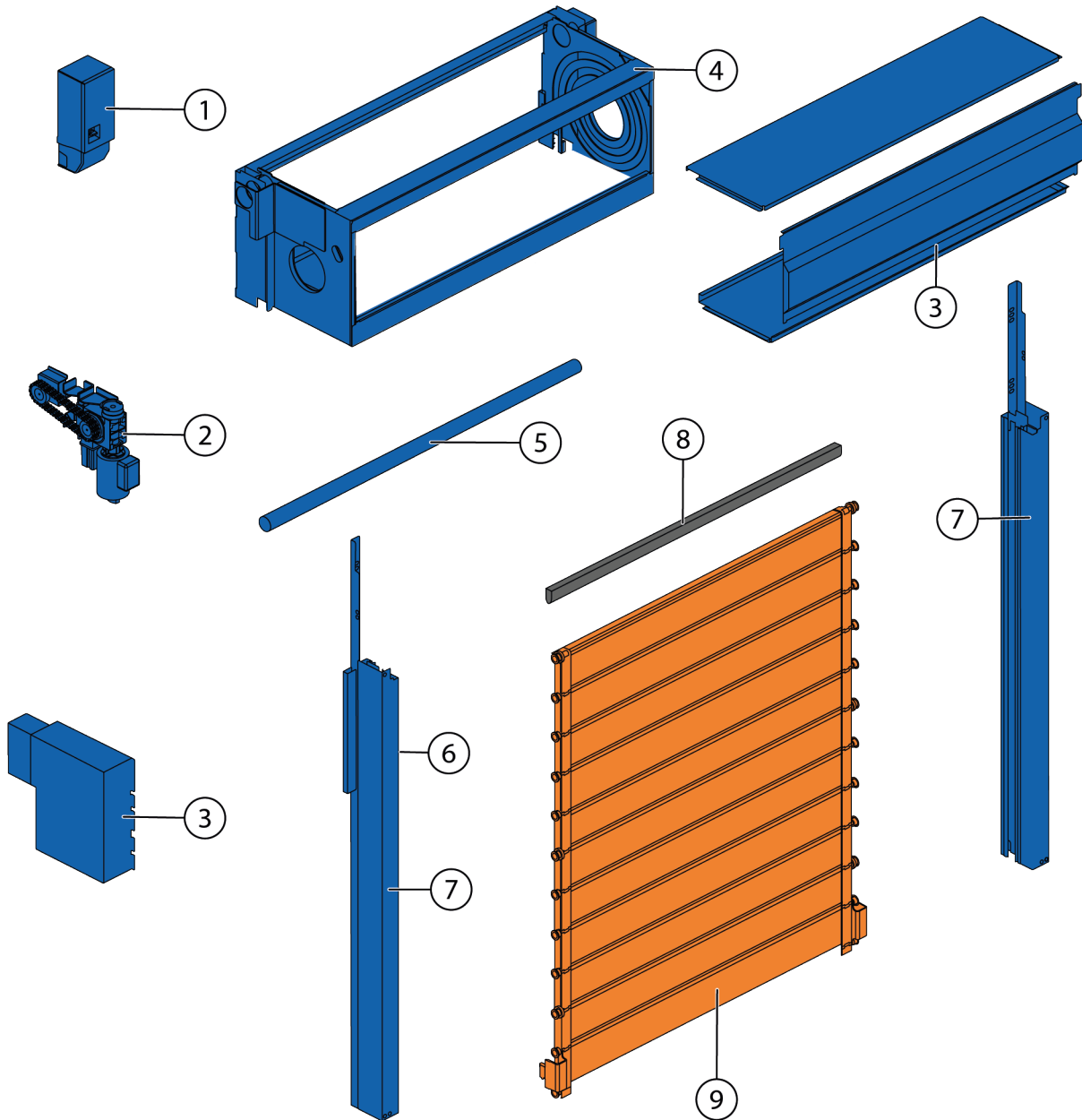

Fig. 4: Assemblies

		<ul style="list-style-type: none"> ↳ 'EFA-TRONIC® control' on page 26 ↳ 'EFA-TRONIC® Professional' on page 27
		↳ 'Drive' on page 25
		↳ 'Spiral case cover (optional)' on page 11
		↳ 'Spiral case' on page 11

High-speed spiral door construction

		↳ 'Spiral case' on page 11
		↳ 'Vertical side frame with door leaf guide' on page 14
		↳ 'Transmission of force' on page 12
		↳ 'Seal' on page 24
		↳ 'Door leaf' on page 16
		↳ "Overview of laths", starting on page 17
		↳ "Safety edge and light barrier" starting on page 29

Spiral case

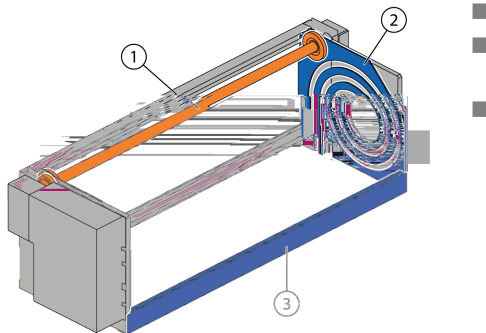

Fig. 5: Spiral case

Spiral case cover (optional)

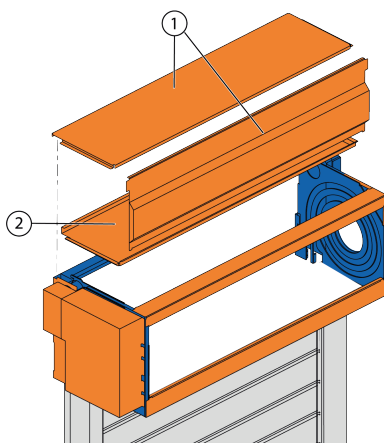

Fig. 6: Spiral case cover

The bottom and front cover reduce the clearance height by 20 mm.



The cover on the spiral case as finger protection is regulation for door systems with a height of less than 2500 mm.

High-speed spiral door construction

Transmission of force

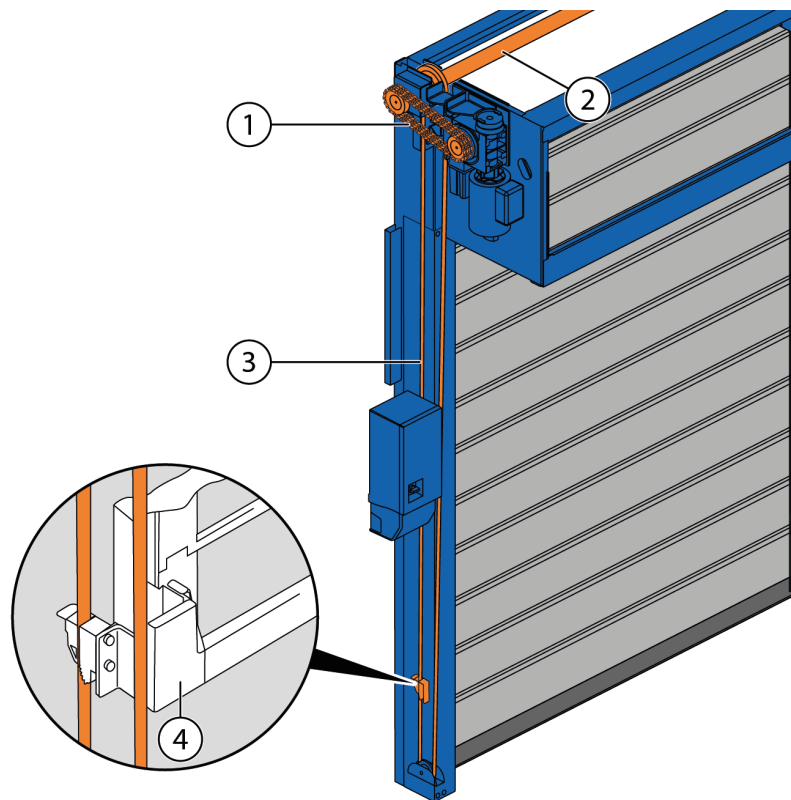

Fig. 7: Transmission of force

Manual emergency operation

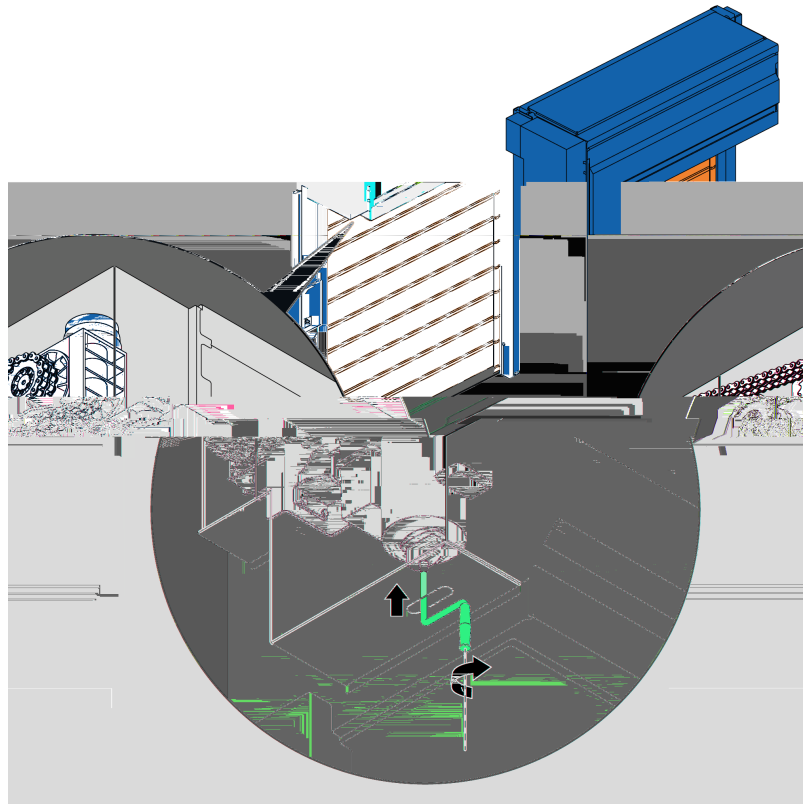

Fig. 8: Manual emergency operation

High-speed spiral door construction

Vertical side frame with door leaf guide

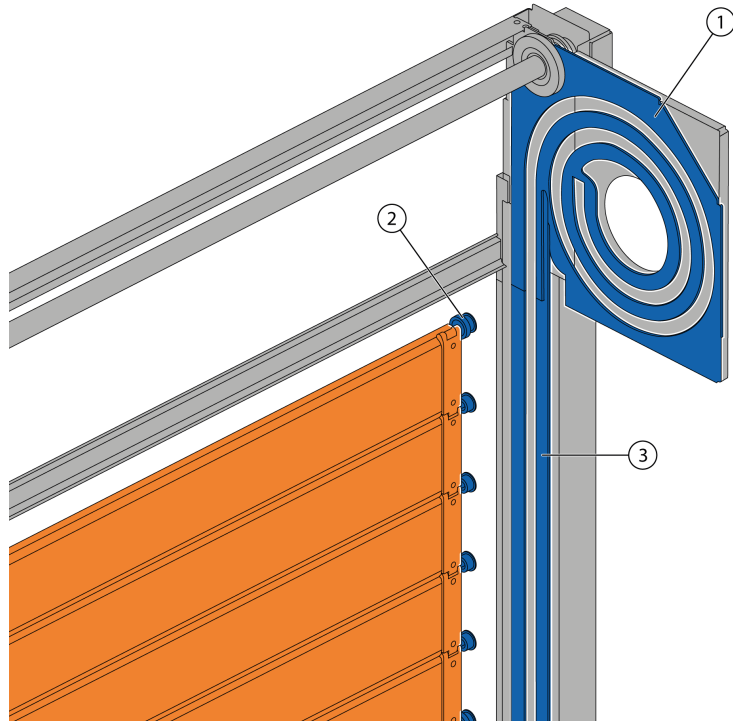

Fig. 9: Door leaf guide

Resistance class 2 (WK2) as defined in DIN V ENV 1627:1999-04 and (RC2) as defined in DIN/TS 18194:2020

”

“



-
-
-
-



Fig. 10: Seal manufacturer directories

High-speed spiral door construction

Door leaf

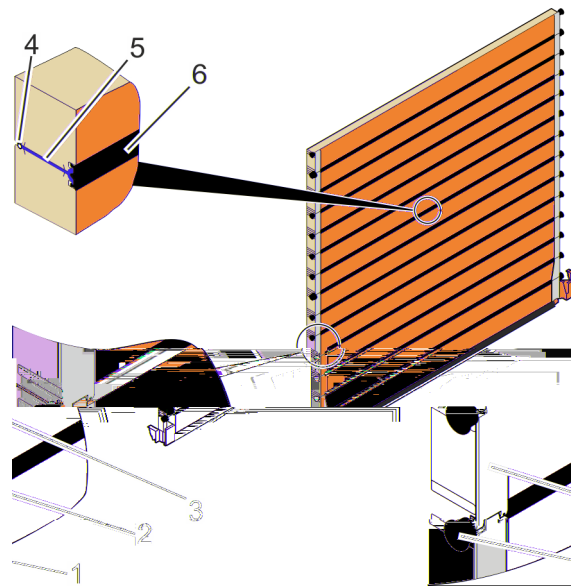

Fig. 11: Door leaf

Structure of the laths

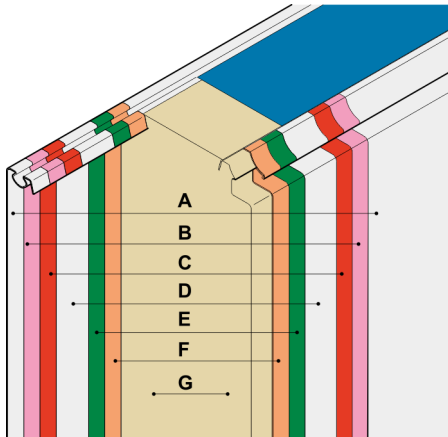

Fig. 12: Structure of the EFA-THERM[®] lath

EFA-THERM[®] lath

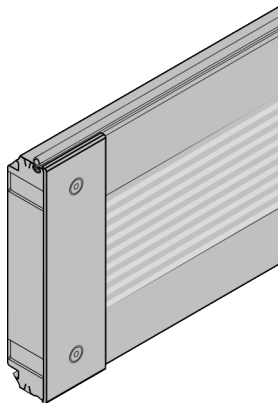

Fig. 13: EFA-THERM[®] lath

	x

High-speed spiral door construction

EFA-CLEAR® transparent lath, double-walled (optional)

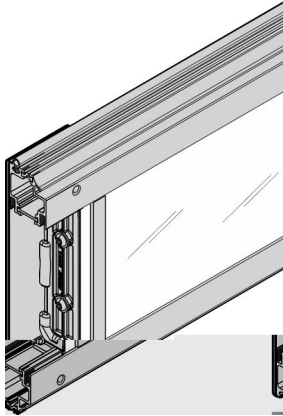

Fig. 14: Transparent lath (double-walled)

	x
	%

EFA-CLEAR® transparent lath, single-walled (optional)

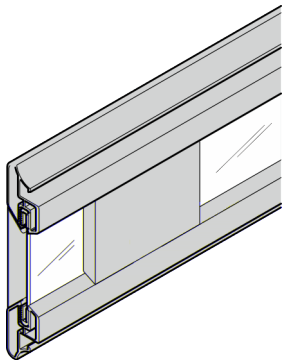
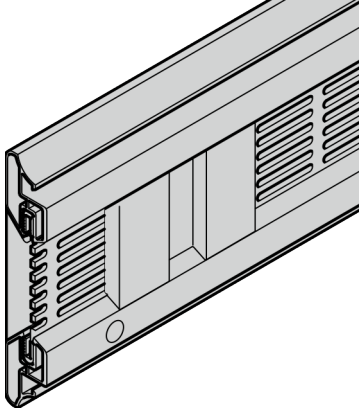

Fig. 15: Transparent lath (single-walled)

	x
	%

EFA-VENT® ventilation lath (optional)



x

	x
	x x

Fig. 16: Ventilation lath

EFA-THERM® lath variants

Door system type 314				

High-speed spiral door construction

LA1

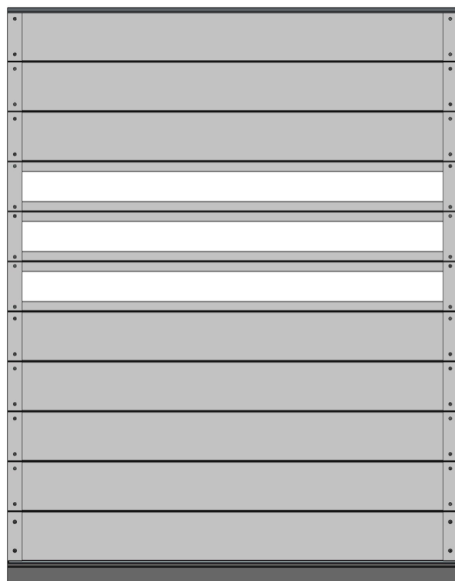

Fig. 17: Door leaf design LA1

LA2

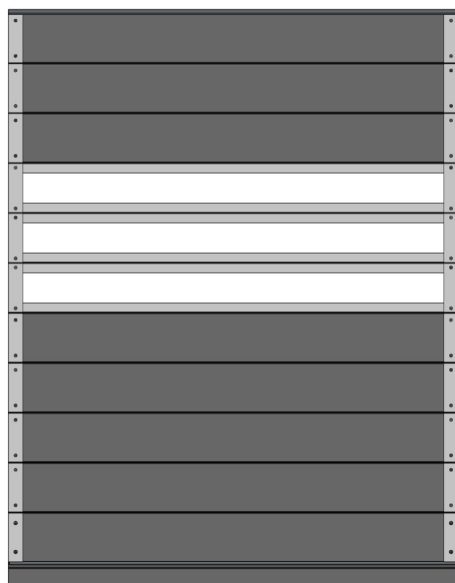

Fig. 18: Door leaf design LA2

LA3

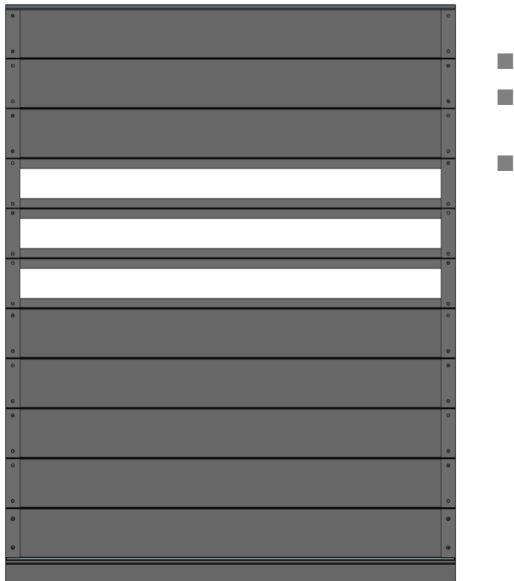

Fig. 19: Door leaf design LA3

LA4

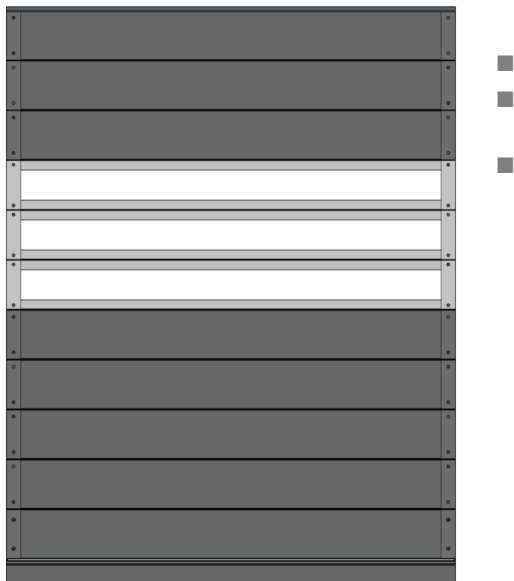

Fig. 20: Door leaf design LA4

High-speed spiral door construction

LA1 (interior)

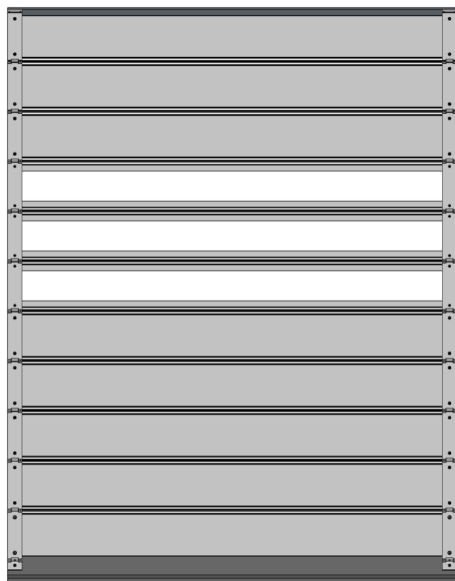

Fig. 21: Door leaf design LA1, interior

LA2 and LA4 (interior)

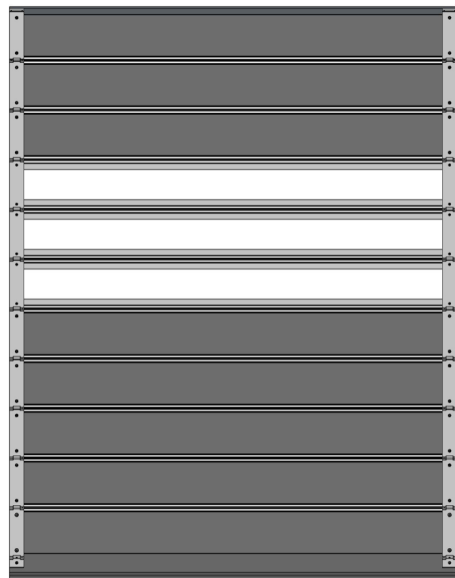

Fig. 22: Door leaf design LA2 and LA4, interior

High-speed spiral door construction

Seal

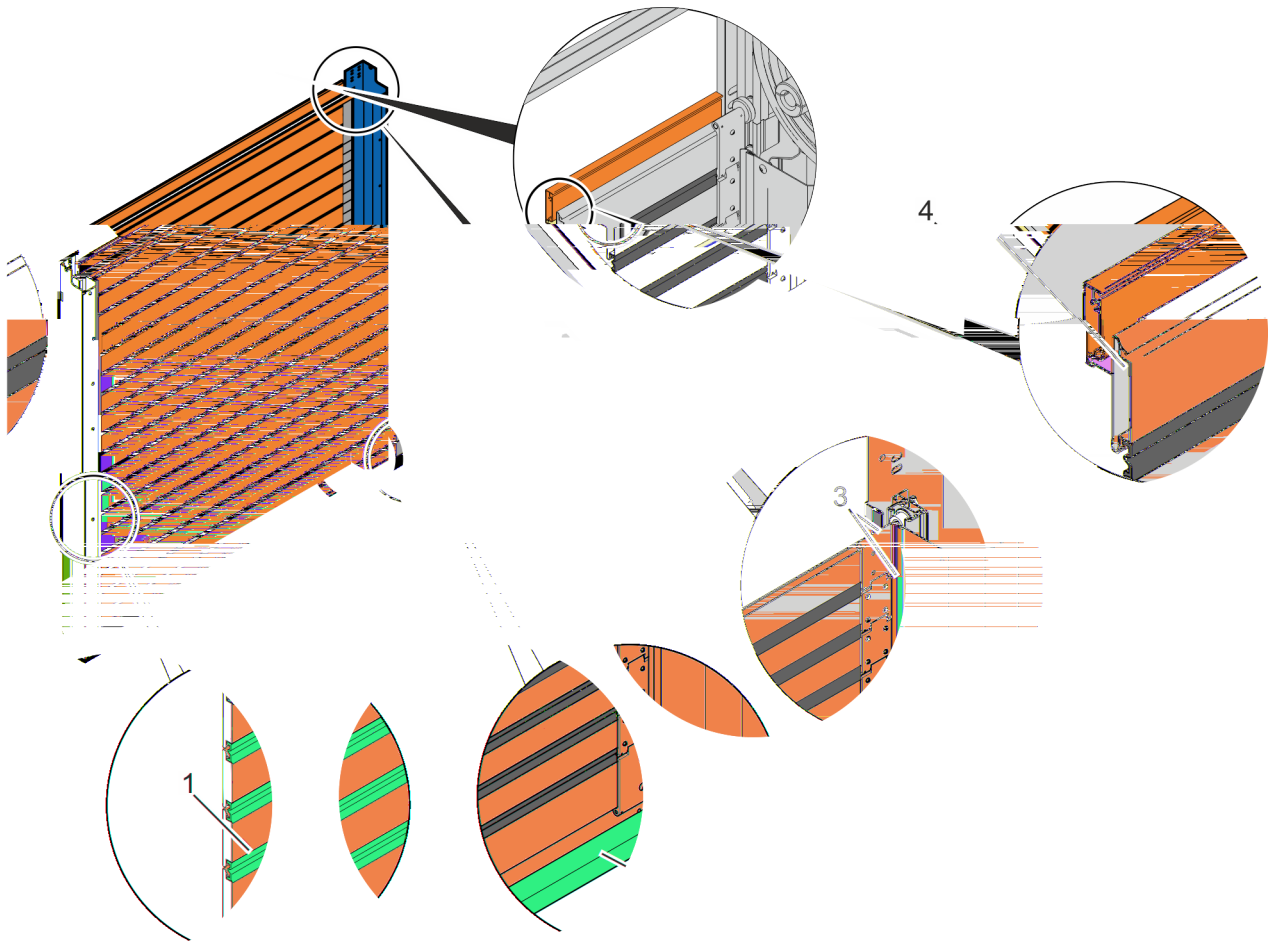

Fig. 24: Seal

High-speed spiral door construction

Drive

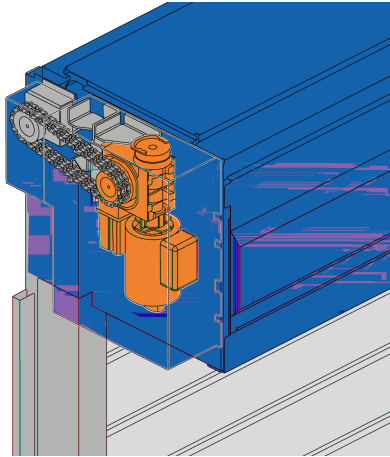

Fig. 25: Drive

Controls

Door system type	EFA-TRONIC®	EFA-TRONIC® Professional	Standard installation position
	●	○	

●

○

High-speed spiral door construction

EFA-TRONIC® control

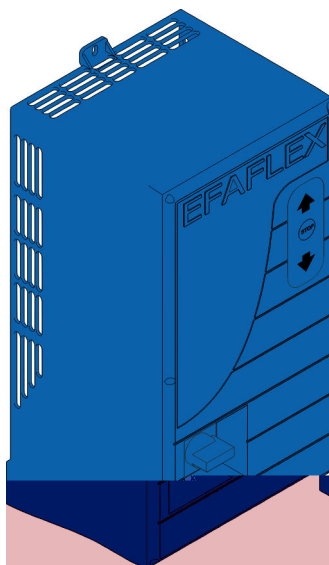

Fig. 26: EFA-TRONIC® control

x x	x x
	~ ±

EFA-TRONIC® Professional

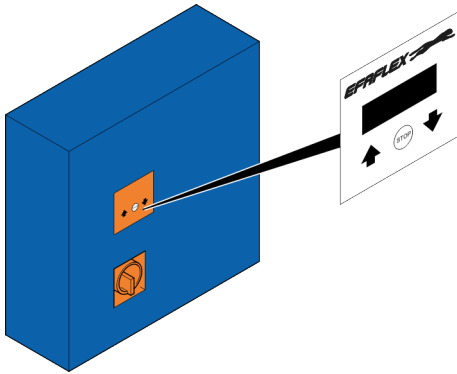

Fig. 27: EFA-TRONIC® Professional

	■
	■
	~

High-speed spiral door construction

EFA-HDI operating unit

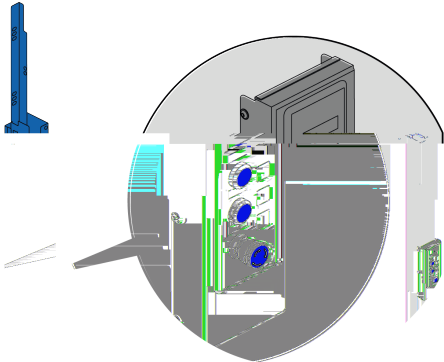

Fig. 28: EFA-HDI operating unit on the side frame

EFA-HDI operating unit

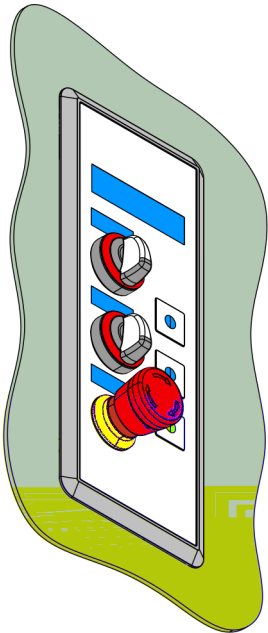

Fig. 29: EFA-HDI operating unit

4 Door safety

Available door safety

Door system type	Safety edge and light barrier	Door light grid
	•	-

•

-

Safety edge and light barrier

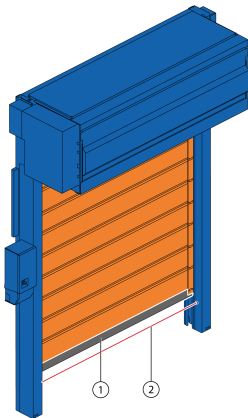

Fig. 30: Safety edge and light barrier

5 Equipment

Possible equipment¹

-
-

○

-
-
-

x

○

-
-
-
-
-
-

■

-
-
-

1

6 Packaging units

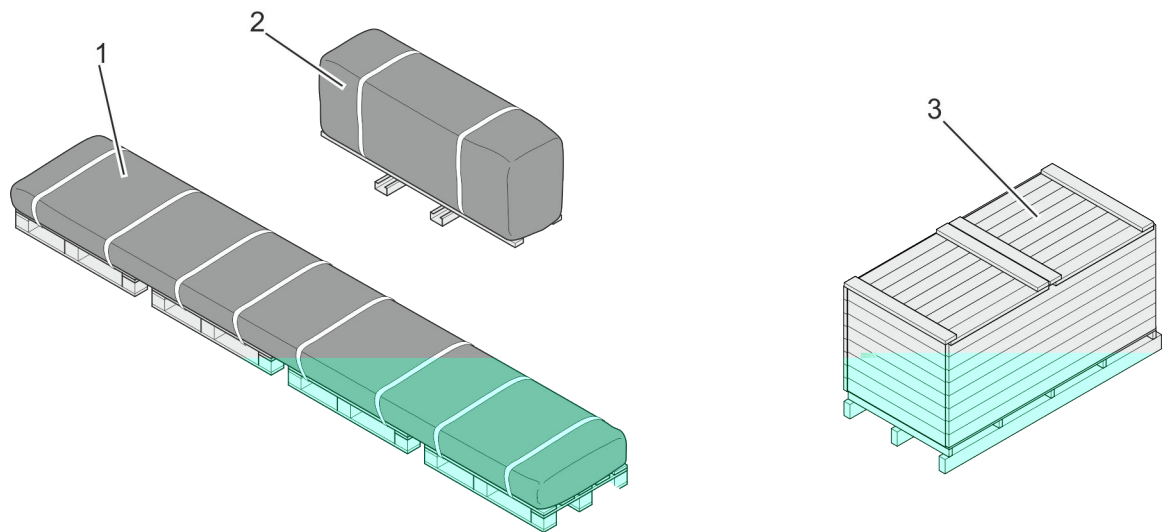

Fig. 31: Scope of delivery



**Fit-for-purpose packaging is packaging that ensures that the packaged goods reach the recipient without damage, taking into account the shipping loads, shipping route, shipping duration and transportation load profile.*

Transport unit (example)

Number of transport units

Packaging units

-
-
-

EFAFLEX



safe high speed drive