



Technical product description
High-speed spiral door
for parking and garage systems

EN

For internal use only

This technical product description applies to
the following door system types:

EFA-SST®-L PS

EFA-SST® PS-N

EFA-SST®-S PS

EFAFLEX Tor- und Sicherheitssysteme GmbH & Co. KG

Fliederstraße 14

84079 Bruckberg

Germany

Telephone: +49 8765 82-0

Fax: +49 8765 82-200

email: info@efaflex.com

Internet: www.efaflex.com

Translation of the original

Version 01-EN

18.12.2015

© EFAFLEX Tor- und Sicherheitssysteme GmbH & Co. KG

Door system designations

Official designation for the door system	Spiral type	Designation in this product description
EFA-SST®-L PS (type 278)	Round spiral	278
EFA-SST® PS-N (type 281)	Low lintel	281
EFA-SST®-S PS (type 304)	Round spiral	304

Table of contents

1	Short description.....	5
2	Technical properties.....	6
3	Construction of the high-speed spiral door.....	10
4	Door safety.....	25
5	Equipment.....	27
6	Packaging units.....	28

1 Short description

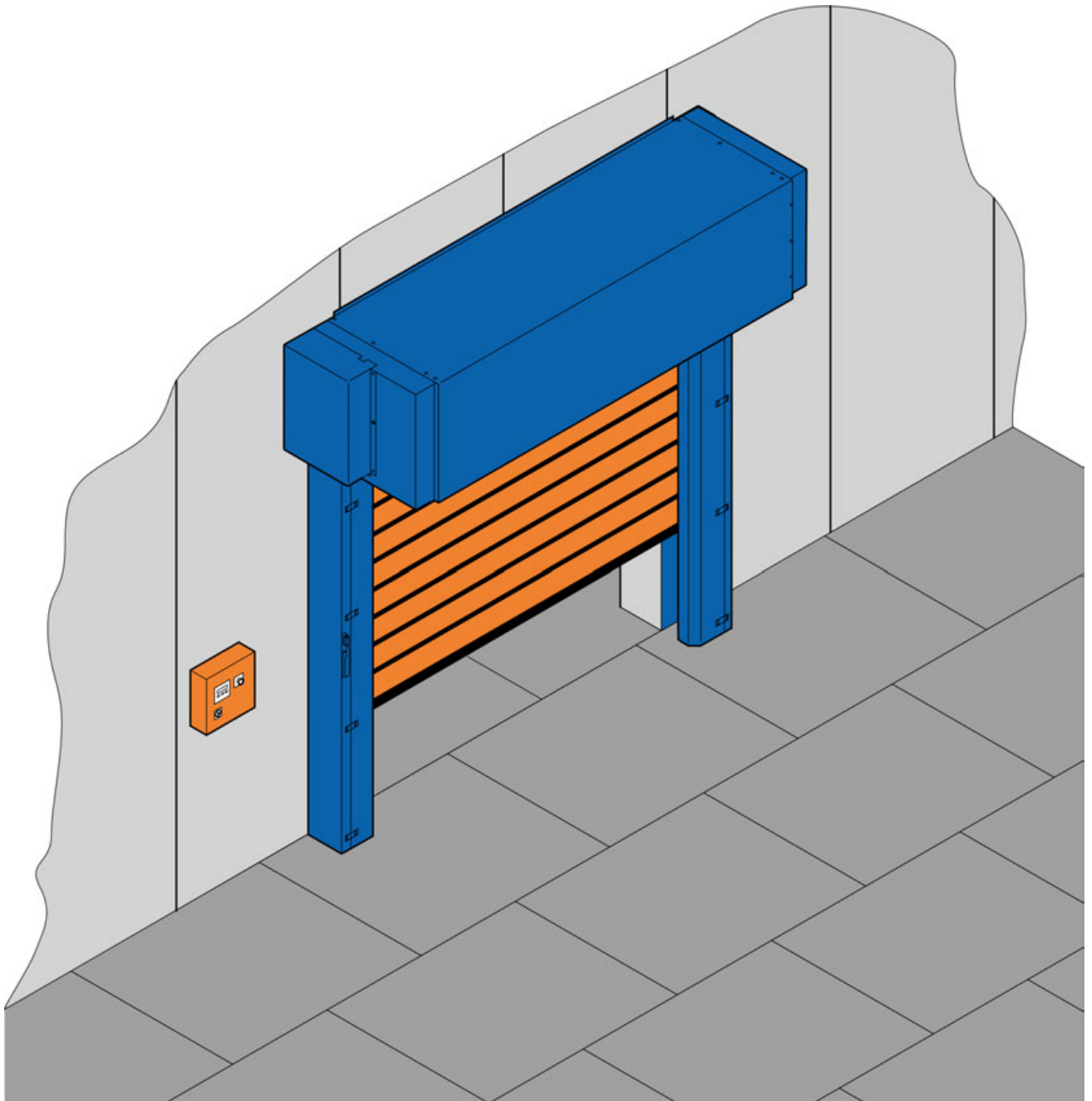

Fig. 1: High-speed spiral door for parking and garage systems

The EFA-SST® PS has been specially developed for parking and garage systems. The basic construction is based on tried and tested spiral door technology. The door leaf with its 105 mm high aluminium laths makes for minimum lintel height requirement.

2 Technical properties

Use

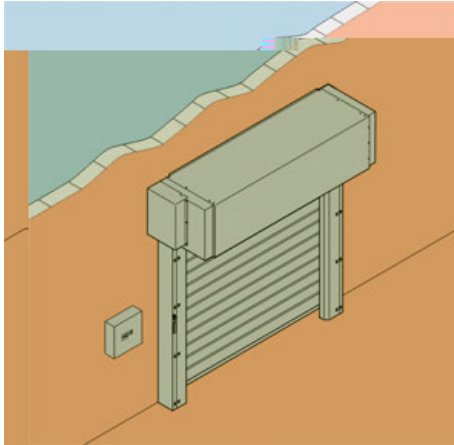

Fig. 2: Use

Use

- Industrial door
- Hall door
- Parking systems
- Garage door

Area of application

- Door for outdoor and indoor use

Temperature range for use

- -15 °C to +50 °C

	Outdoor (-15 °C to +50 °C)
	Indoor (+5 °C to +50 °C)

Dimensions for door system 278

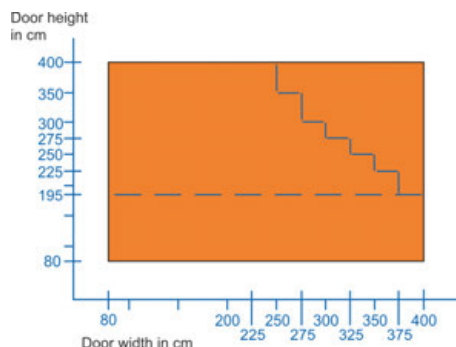

Fig. 3: Diagram of possible door system heights and door system widths (278)

With regard to door system type 278, there are two different structural designs for the side frame on the drive side: “P1” and “P2”. Structural design P2 is a large-sized side frame with space for springs in addition to the springs located in the opposing side frame.

P2 is absolutely essential for door system dimensions in the range to the right of the scaled line (Fig. 3). P1 is intended for door system dimensions in the range to the left of the scaled line (Fig. 3). However, P2 can also be installed in such cases depending on the drive variant (☞ ‘Drive’ on page 21).

i With regard to door heights below 1950 mm, it is not possible to use a door light grid.

Door system heights and widths (clear passage dimensions)

Door system type	Widths	Heights
278 (P1)	800–2500 mm	800–4000 mm
	2501–2750 mm	800–3500 mm
	2751–3000 mm	800–3000 mm
	3001–3250 mm	800–2750 mm
	3251–3500 mm	800–2500 mm

Door system type	Widths	Heights
	3501–3750 mm	800–2250 mm
	3751–4000 mm	800–1950 mm
278 (P2)	2500–2750 mm	3500–4000 mm
	2751–3000 mm	3000–4000 mm
	3001–3250 mm	2750–4000 mm
	3251–3500 mm	2500–4000 mm
	3501–3750 mm	2250–4000 mm
	3751–4000 mm	800–4000 mm

Dimensions for door system 281

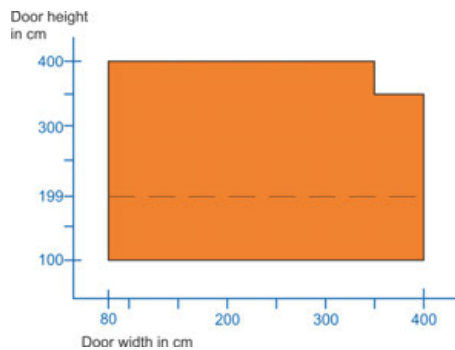

Fig. 4: Diagram of possible door system heights and door system widths (281)



With regard to door heights below 1990 mm, it is not possible to use a door light grid.

Door system heights and widths (clear passage dimensions)

Door system type	Widths	Heights
281	800–3500 mm	1000–4000 mm
	3501–4000 mm	1000–3500 mm

Dimensions for door system 304

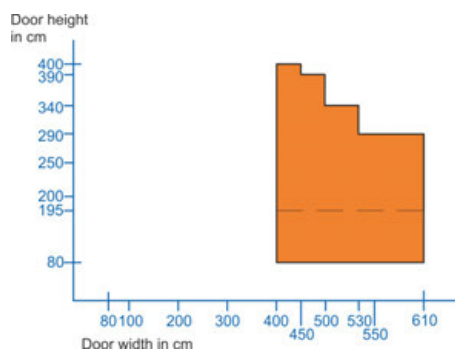

Fig. 5: Diagram of possible door system heights and door system widths (304)



With regard to door heights below 1950 mm, it is not possible to use a door light grid.

Door system heights and widths (clear passage dimensions)

Door system type	Widths	Heights
304	4000–4500 mm	800–4000 mm
	4501–5000 mm	800–3900 mm
	5001–5300 mm	800–3400 mm
	5301–6100 mm	800–2900 mm

Technical properties

Speeds

Door system type	Average speed (max. speed)		
	Opening speed	Closing speed with door light grid	Closing speed with safety edge and light barrier
278	1.8 m/s (2.0 m/s)	1.0 m/s	0.5 m/s
281	1.2 m/s (1.5 m/s)	1.0 m/s	0.5 m/s
304	1.2 m/s (1.5 m/s)	1.0 m/s	0.5 m/s

Speed dependent on the height of the door system

Performance properties as per DIN EN 13241-1

278	
Indication	Value
Resistance to wind load as per DIN EN 12424	Class 4
Resistance to water penetration as per DIN EN 12425	Class 2
Air permeability as per DIN EN 12426	Class 1
Airborne sound insulation as per EN ISO 717-1 (aluminium laths only)	Rw = 23 dB
Thermal insulation as per DIN EN 12428 (with door system 4000 x 4000, only for aluminium laths)	U = 6.5 W/m ² K

281	
Indication	Value
Resistance to wind load as per DIN EN 12424	Class 4
Resistance to water penetration as per DIN EN 12425	Class 0
Air permeability as per DIN EN 12426	Class 0
Airborne sound insulation as per EN ISO 717-1 (aluminium laths only)	Rw = 23 dB
Thermal insulation as per DIN EN 12428 (with door system 4000 x 3500, only for aluminium laths)	U = 6.6 W/m ² K

304	
Indication	Value
Resistance to wind load as per DIN EN 12424	Class 2
Resistance to water penetration as per DIN EN 12425	Class 2
Air permeability as per DIN EN 12426	Class 1
Airborne sound insulation as per EN ISO 717-1 (aluminium laths only)	Rw = 23 dB
Thermal insulation as per DIN EN 12428 (with door system 4000 x 4000, only for aluminium laths)	U = 6.5 W/m ² K

Fire performance as per DIN 4102

Data	Value
Material class	B2 normally inflammable

Applied safety standards

The following standard was applied for planning, engineering and production: DIN EN 13241-1 Doors – Product standard

Performance

Data	Value
Load changes per year	200 000
Service life	10 years

3 Construction of the high-speed spiral door

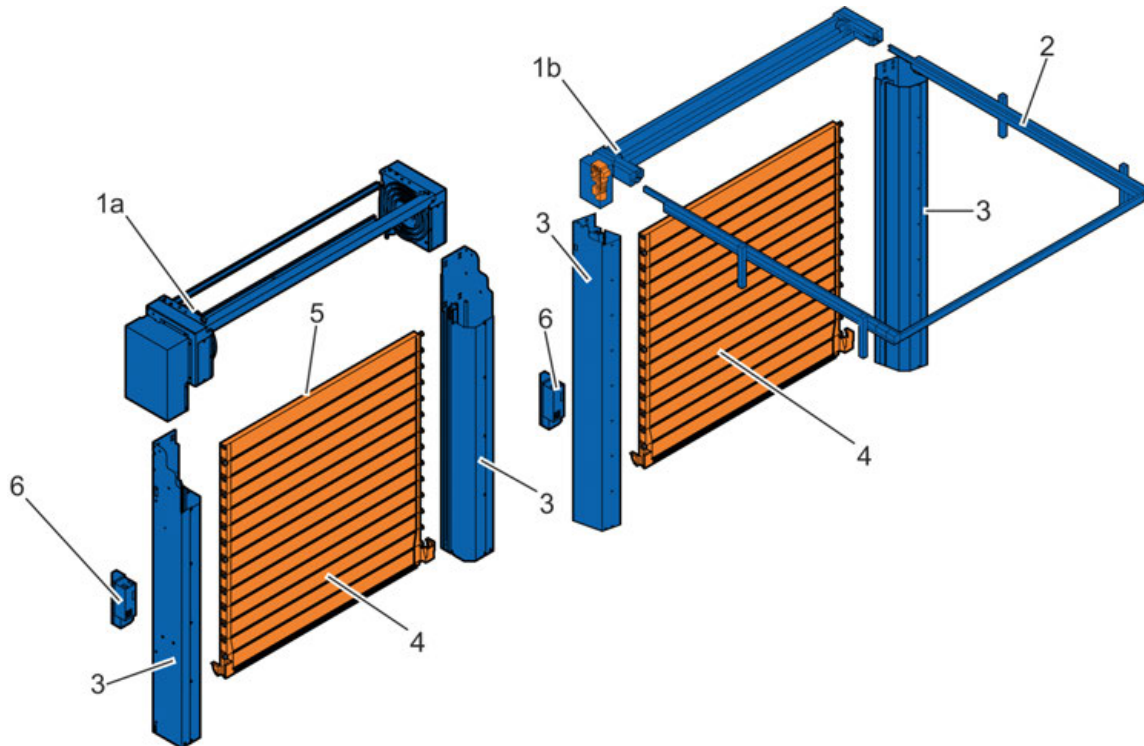

Fig. 6: Assemblies 278/304 (left) and 281 (right)

1	Round (Fig. 6/1a) or low spiral console (Fig. 6/1b) with main support, spiral guide, motor, drive shaft, bearing, reinforcement profiles, cover (optional)	<ul style="list-style-type: none"> ↳ 'Spiral console' on page 11 ↳ 'Round spiral console cover (optional, 278/304)' on page 12 ↳ 'Round spiral console cover (optional, 278/304)' on page 12 ↳ 'Drive' on page 21
2	Side frames with horizontal door leaf guide, door leaf belt and support	↳ 'Transmission of force (281)' on page 13
3	Side frames with vertical door leaf guide, counterbalance and safety devices (light barriers and door light grids)	<ul style="list-style-type: none"> ↳ 'Side frames with door leaf guide' on page 17 ↳ 'Counterbalance' on page 14
4	Door leaf	↳ 'Door leaf' on page 17
	Laths	<ul style="list-style-type: none"> ↳ 'Lath' on page 18 ↳ 'Sight lath (optional)' on page 18 ↳ 'Ventilation lath (optional)' on page 19
	Safety edge	

Construction of the high-speed spiral door

5	Horizontal seal	☞ 'Seal' on page 19
6	Control unit	

Spiral console

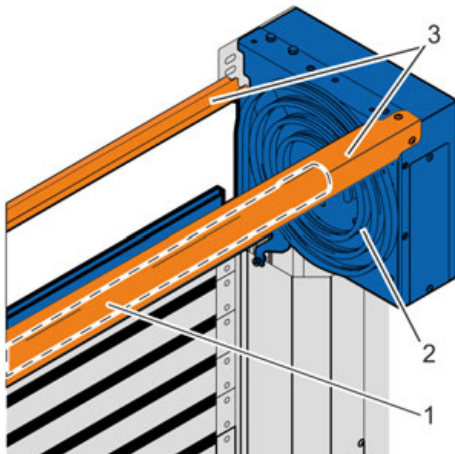

Fig. 7: Round spiral console (278, 304)

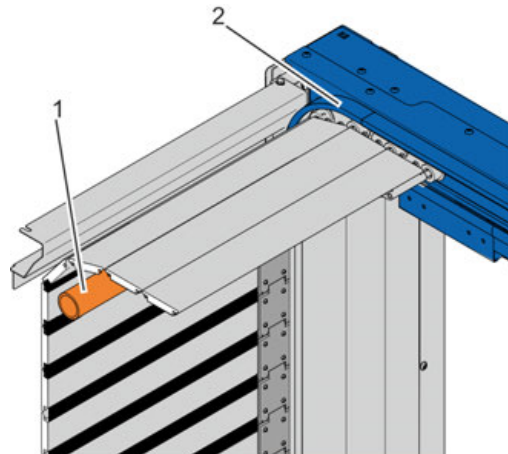

Fig. 8: Low spiral console (281)

The spiral console has a “round” design for door system types 278 and 304 and a “low” design for door system type 281.

The spiral console comprises:

- Synchronous shaft with bearing (Fig. 7/1 and Fig. 8/1)
- Bevelled, main supports with spiral guide (Fig. 7/2) on both sides or horizontal guide (Fig. 8/2)
- Sheet metal reinforcement profiles (only for 278 and 304 Fig. 7/3)

Construction of the high-speed spiral door

Round spiral console cover (optional, 278/304)

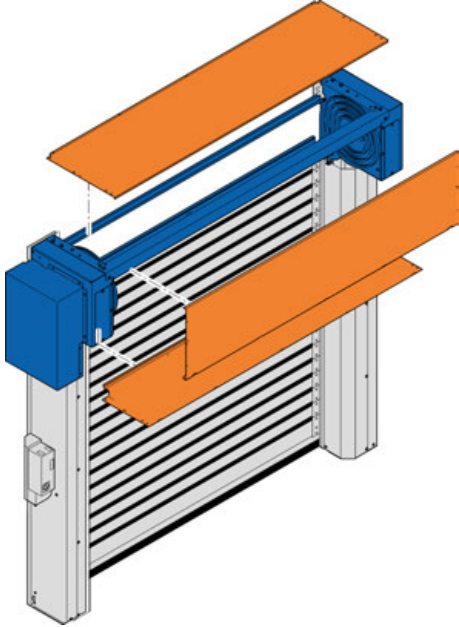

Fig. 9: Round spiral console cover with sheet metal covers (278/304)

The cover of the spiral console is made up of sheet metal covers.

The spiral console can optionally be covered at the bottom, front and top. The clearance height is consequently reduced by 40 mm

The cover on the front and bottom are only possible in combination. The top cover is only possible if the front and bottom are also covered.

The cover on the spiral console as a protective guard is regulation for door systems with a height of less than 2500 mm.

Low spiral console cover (optional, 281)

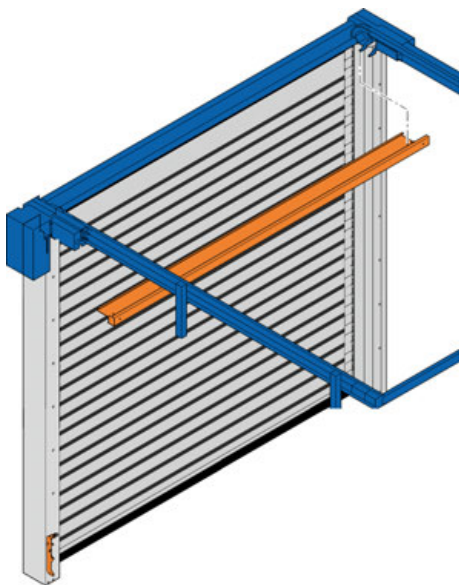
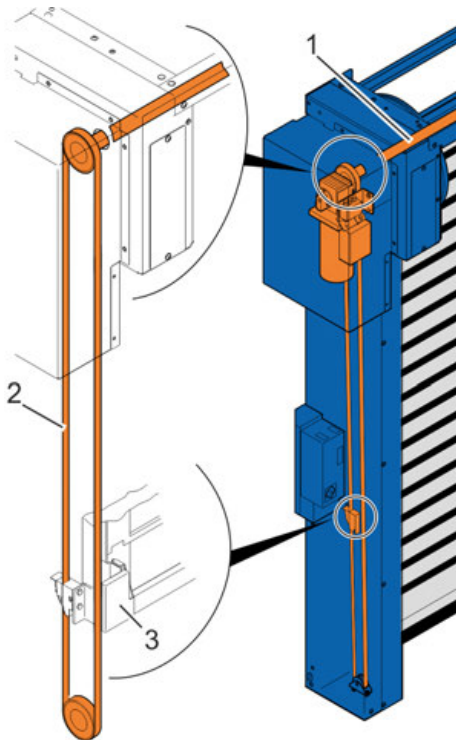

Fig. 10: Low spiral console cover (281)

The lower area between the two consoles can be covered with optional sheet metal covers.

The cover on the spiral console as a protective guard is regulation for door systems with a height of less than 2300 mm with low lintel.

Transmission of force (278/304)



The transmission of force from the drive to the door leaf is performed by the synchronous shaft (Fig. 11/1), the continuous toothed belt (Fig. 11/2) and the door leaf mounts (Fig. 11/3). Unlike a chain, the toothed belt runs very quietly.

Fig. 11: Round spiral transmission of force (278/304)

Transmission of force (281)

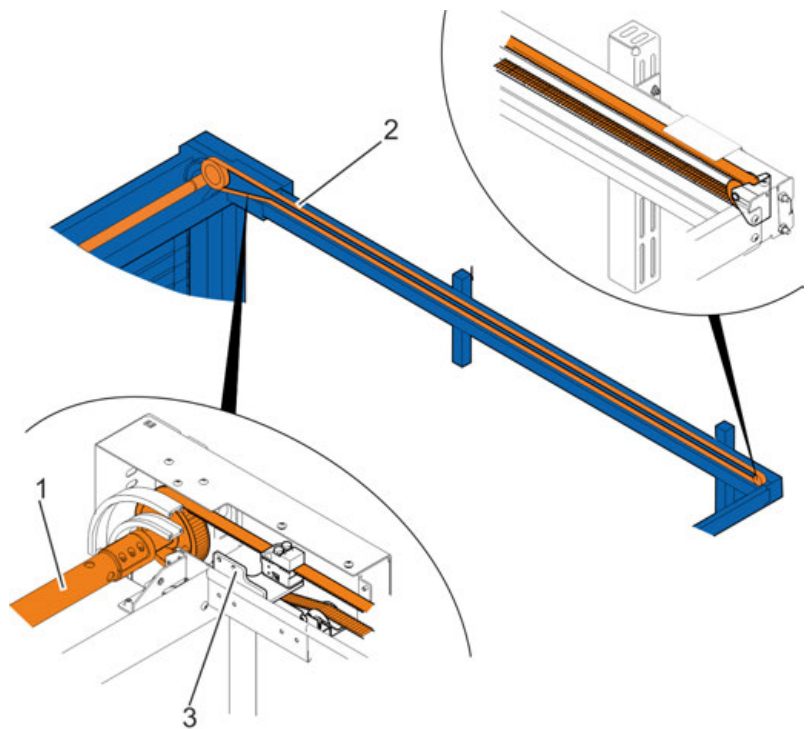

Fig. 12: Low lintel transmission of force (281)

Construction of the high-speed spiral door

The horizontal side frames are made up of bevelled sheet metal covers and an aluminium guide and are fitted to the ceiling with supports. Protection from reaching in to prevent finger injuries is provided by low-wear door leaf seals.

The transmission of force from the drive to the door leaf is performed by the synchronous shaft (Fig. 12/1), the continuous toothed belt (Fig. 12/2) and the door leaf mount (Fig. 12/3). Unlike a chain, the toothed belt runs very quietly.

Counterbalance

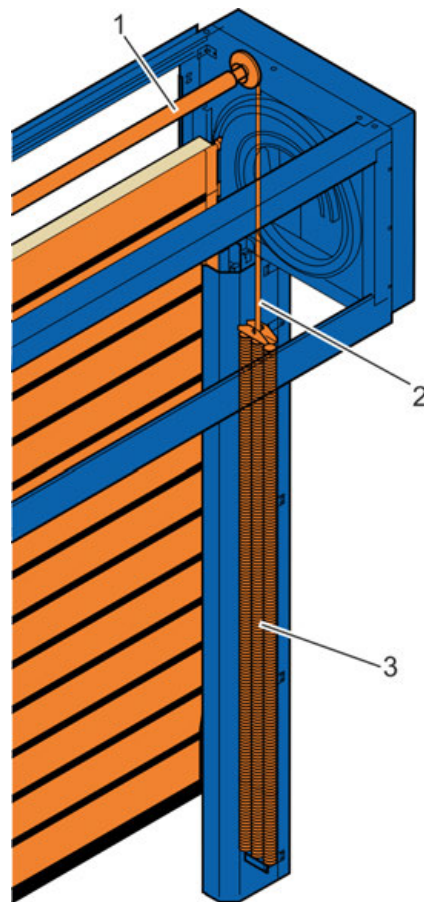

Fig. 13: Counterbalance

The door leaf counterbalance is a back pull mechanism: Tension springs (Fig. 13/3) are installed in the side frames. The tension springs are connected to the synchronous shaft (Fig. 13/1) by heavy-duty belts (Fig. 13/2). The tension springs are tensioned when the door system is closed and relaxed when the door system is open.

This way the door system can also be opened by hand (without electrical power) in case of emergencies. In normal mode the motor is assisted by the force of the tension springs.

The spring tension is calculated for each individual order.

Emergency lever

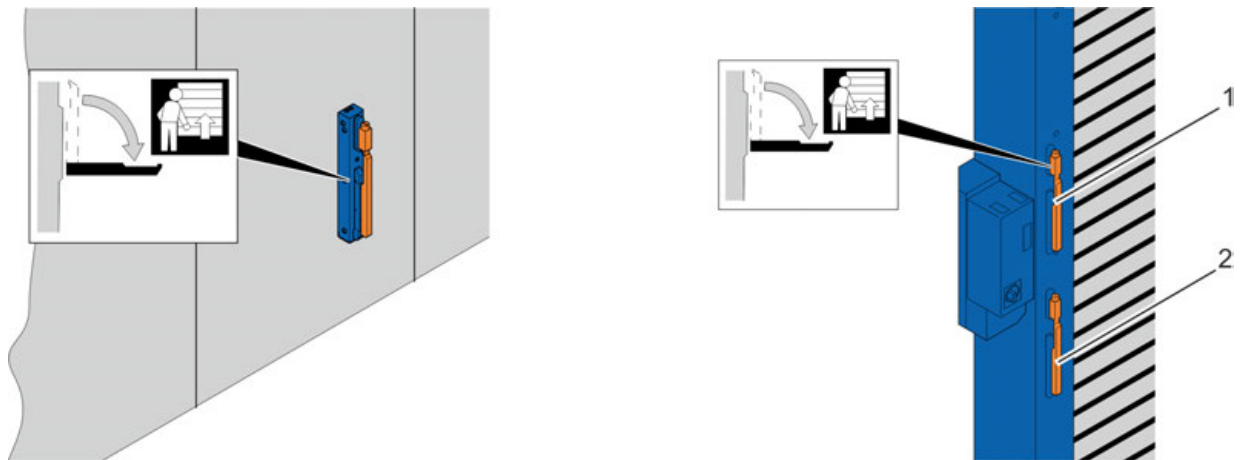

Fig. 14: Emergency lever on separate console (left) and on the side frame (right)

- 1 Emergency lever
- 2 Lever for door locking mechanism (optional)

The emergency lever is situated on the side frame or optionally on a separate console. When the lever is pulled, the drive brake is enabled and the door system is partially opened automatically by the tension springs of the counterbalance system. The door system can be opened completely by pushing the door leaf upwards. The control unit is in EMERGENCY STOP status during this operation.

Door locking mechanism (278/304, optional)

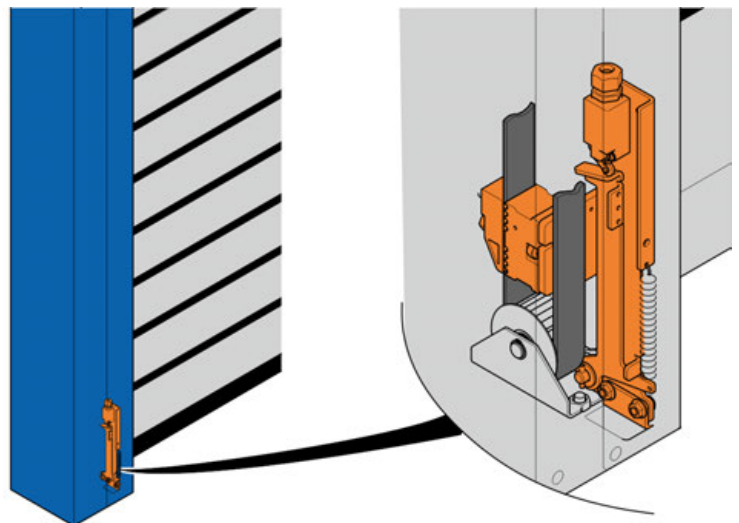

Fig. 15: Door locking mechanism

The mechanical locking mechanism is installed in the vertical side frame on the motor side. The locking mechanism handle keeps the door leaf closed so that it is safe from break-ins. The door locking mechanism is operated using a lever which is fitted to the side frame or on an optional separate console.

Construction of the high-speed spiral door

Door locking mechanism (281, optional)

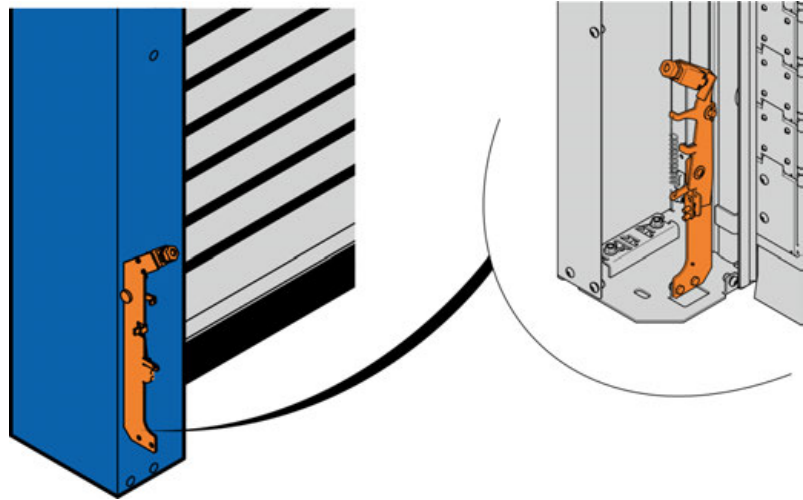

Fig. 16: Door locking mechanism

The mechanical locking mechanism is installed in the vertical side frame on the motor side. The locking mechanism handle keeps the door leaf closed so that it is safe from break-ins. The door locking mechanism is operated using a lever which is fitted in the side frame.

Possible designs for the door locking mechanism

Standard version: Lever attached to the side frame		Optionally: Lever attached to the side frame with reversed lever position		Optionally: Lever attached to a separate console
Door leaf not locked	Door leaf locked	Door leaf not locked	Door leaf locked	
Lever position: Lever up	Lever position: Lever down	Lever position: Lever down	Lever position: Lever up	The lever position depends on laying of Bowden cable
Optional locking version			Optional locking version	Lever position up, optional locking version

Side frames with door leaf guide

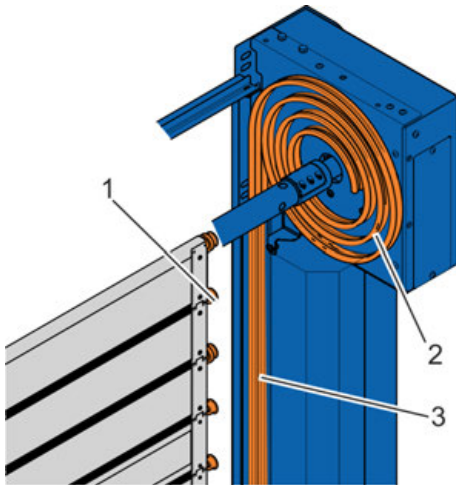

Fig. 17: Door leaf guide (round spiral, 278/304)

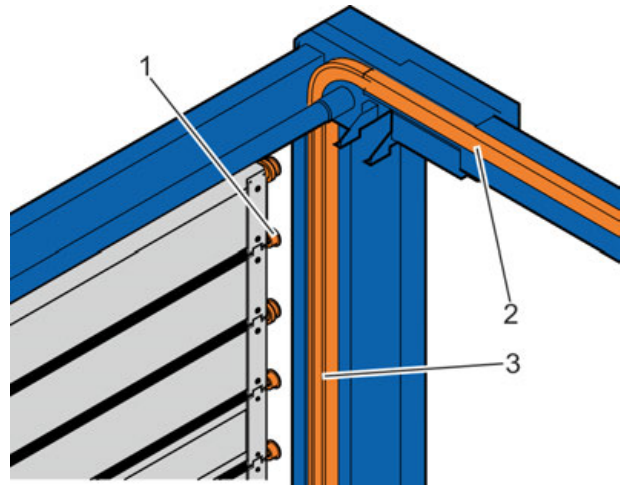

Fig. 18: Door leaf guide (low lintel, 281)

The door leaf comprises laths which are connected by a hinge chain. Rollers (Fig. 17/1 and Fig. 18/1) are attached to the hinge chain. When the door system is opened and closed, the rollers are directed through the horizontal (Fig. 18/2) and vertical (Fig. 18/3) or spiral-shaped (Fig. 17/2) door leaf guide. The rolling of the rollers in the door leaf guide generates very little noise. The roller friction also makes for minimum wear on the rollers as no soiling is generated from abrasion. There is no wear on the door leaf itself. This means that the door system has a long service life.

The vertical door leaf guides (Fig. 18/3) are made of sheet metal and aluminium covers and are situated within the side frames. Each side frame is made up of one main bevelled sheet metal profile and one bevelled sheet metal cover profile. The sheet metal cover profiles are fastened with screws. Optionally they can also be supplied in a pivoting design with hinges.

Door leaf

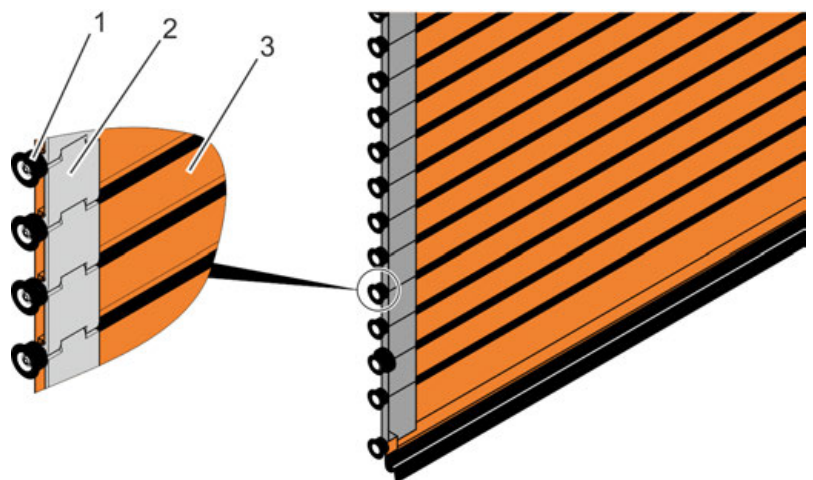

Fig. 19: Door leaf

Construction of the high-speed spiral door

The door leaf is assembled from laths (Fig. 19/3) which are held at the correct spacing by hinge chains (Fig. 19/2) attached at the sides. This spacing prevents contact between the laths. They are thus free from wear. The forces for opening and closing the door system are transmitted via the hinges.

Ball-bearing mounted rollers (Fig. 19/1) keep the door leaf firmly in the guides in the horizontal direction. The laths are connected by rubber hinge profiles.

This homogeneous door leaf construction ensures the very good running performance and the high running speed.

Lath

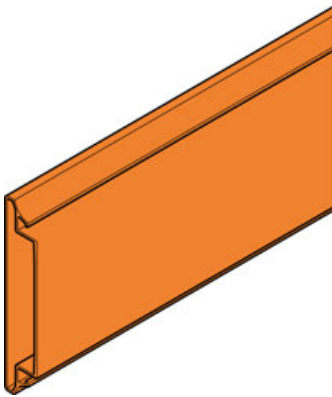

Fig. 20: Lath

The aluminium laths are made of a double-walled extruded profile.

Dimensions	20 x 105 mm (278, 281); 30 x 105 (304)
Finish	Anodised E6/EV1
Optional	Powder coating, colours as per RAL

Sight lath (optional)

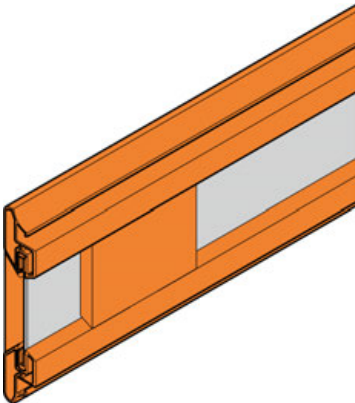

Fig. 21: Sight lath

The sight laths comprise transparent plastic panes pressed into the aluminium profiles.

Dimensions	20 x 105 mm (278, 281); 30 x 105 (304)
Height of the viewing area	Approx. 39 mm
Finish	Anodised E6/EV1
Glazing	SAN panes Hard polycarbonate panes, scratch resistant (278, 281)
Optional	Powder coating for aluminium profiles, colours as per RAL

The number of sight laths is limited.

Construction of the high-speed spiral door

Ventilation lath (optional)

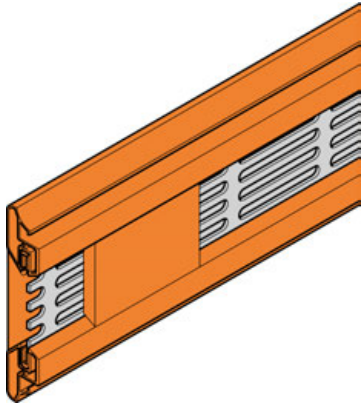

Fig. 22: Ventilation lath

The ventilation laths comprise aluminium metal sheets with elongated holes (50 x 6 mm) which are pressed into the aluminium profiles.

Dimensions	20 x 105 mm (278, 281); 30 x 105 (304)
Finish	Anodised E6/EV1
Vent cross section	$LA = ((B-0.110) * 0.020) * \text{number of laths}$ W = door system width in metres
Optional	Powder coating for aluminium profiles and ventilation sheets, colours as per RAL

The number of ventilation laths is limited.

Seal

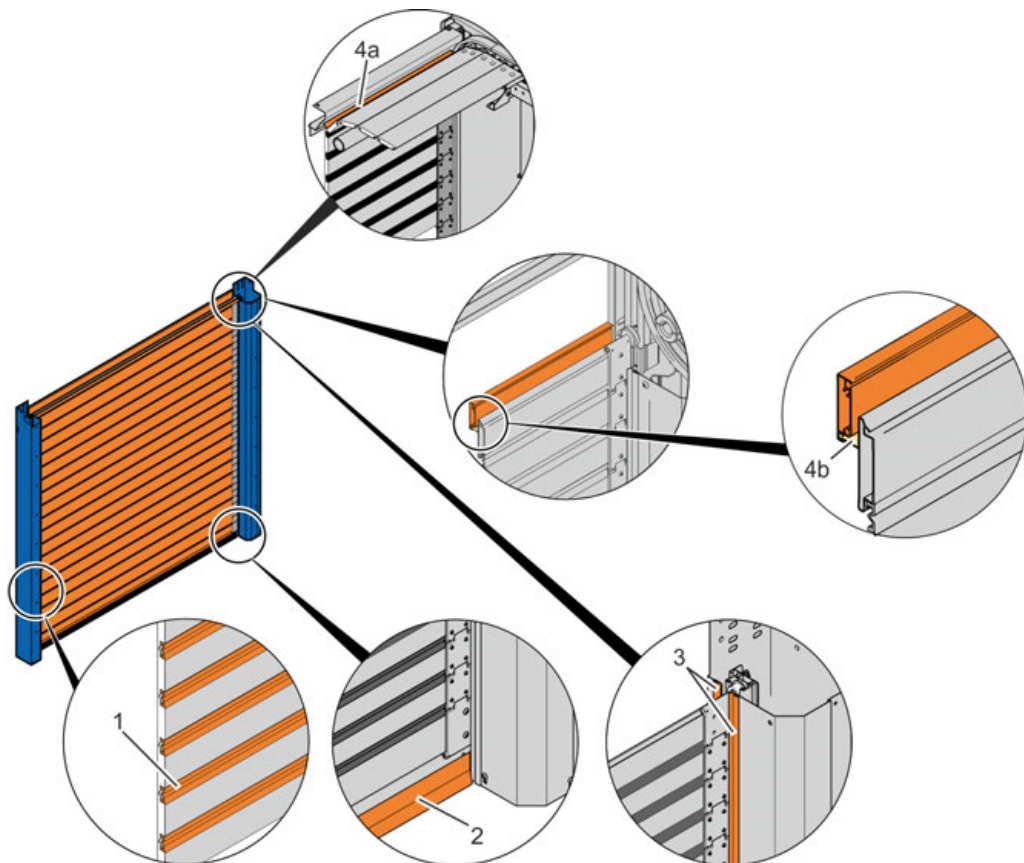

Fig. 23: Seal 278/304 (4a) und 281 (4b)

The low-wear plastic door leaf seals (Fig. 23/3) provide the vertical sealing effect. The rubber profiles perform this function in the horizontal direction (Fig. 23/2). The laths are sealed off by rubber hinges one below the other (Fig. 23/1).

Construction of the high-speed spiral door

The top of the door system is sealed by a sealing profile, which is mounted between the consoles or on the lintel and by additional profiles with a rubber lip which, depending on the door system type and size, are attached to the uppermost 1 - 3 laths. If the door system is closed, the rubber lip on the sealing profile effects the sealing (278/304: Fig. 23/4a; 281: Fig. 23/4b).

Construction of the high-speed spiral door

Drive

Depending on the installation situation the drive can be attached on the side, next to the console (standard) or underneath the console (optional).

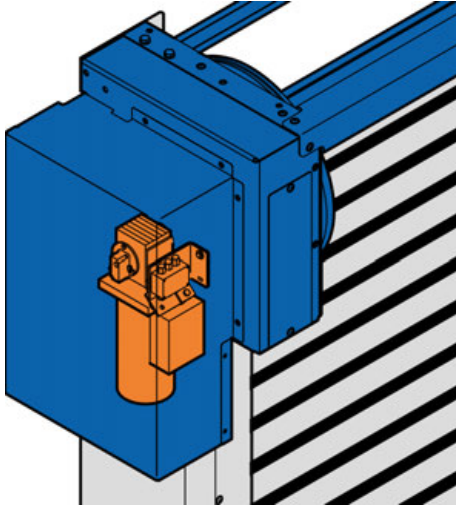

Fig. 24: Drive on the side of the console (278/304)

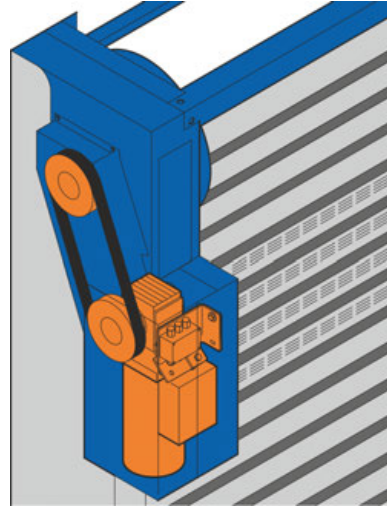

Fig. 25: Drive at an oblique angle on the side underneath the console (304 and only possible for 278 with the P2 structural design
 ↪ 'Dimensions for door system 278' on page 6)

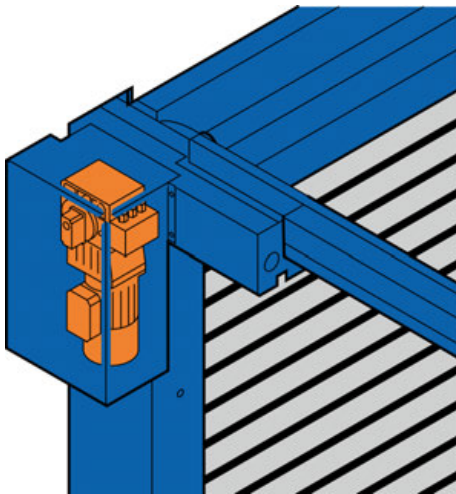

Fig. 26: Drive on the side of the console (281)

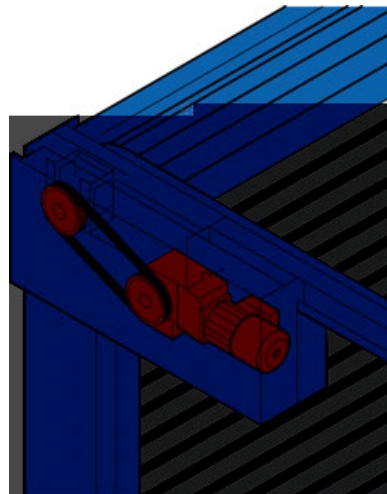

Fig. 27: Drive underneath the console (281)

Drive type	Direct mount drive Asynchronous AC motor with spur gear
Power classes	1.1 kW / 120 Hz
Protection type	IP 54
Position detection	Absolute encoder

Construction of the high-speed spiral door

Control units

Door system type	EFA-TRONIC®	EFA-CON®	mcp®2	EFA-CON® Industrial
278	Standard	Optional	Optional	Optional
281	Standard	Optional	Optional	Optional
304	Standard	Optional	Optional	Optional

EFA-TRONIC® control unit

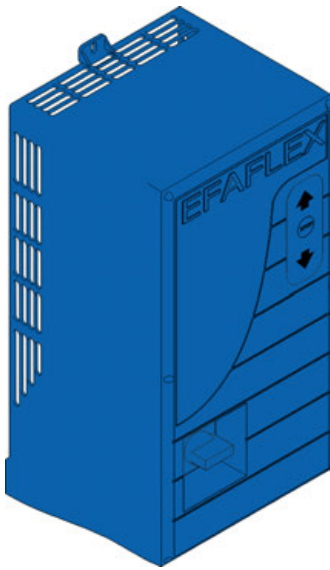

Fig. 28: EFA-TRONIC® control unit

Control unit	EFA-TRONIC® with frequency converter
Size	565 x 210 x 200 mm (including cable hood)
Housing	Polycarbonate housing
Protection type	IP65
Viewing window for display screen	Display for status and fault messages
Operating controls	Operating panel for operation and parameterisation of the door system Master switch
Supply voltage	L/N/PE 230 V +/- 10 % (400 V version provisionally available from 04/2016)
Frequency	50–60 Hz
Supply cable	Fuse protection of 16 A to be provided by the user (K characteristic)
With residual-current circuit breaker (RCCD) as necessary	300 mA as per DIN VDE 0100-530 (AC/DC sensitive)

EFA-CON® control unit

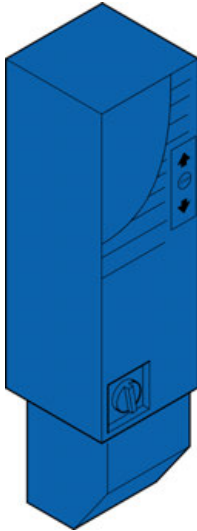

Fig. 29: EFA-CON® control unit

Control unit	EFA-CON® with frequency converter
Size	530 x 160 x 160 mm
Housing	Polycarbonate housing
Protection type	IP65
Viewing window for display screen	Display for status and fault messages
Operating controls	Operating panel for operation and parameterisation of the door system Master switch
Supply voltage	L/N/PE 230 V +/- 10%
Frequency	50–60 Hz
Supply cable	Fuse protection of 16 A to be provided by the user (K characteristic)
With residual-current circuit breaker (RCCD) as necessary	300 mA as per DIN VDE 0100-530 (AC/DC sensitive)

Control unit mcp@2

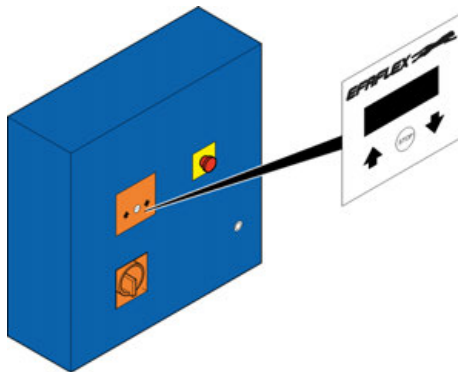

Fig. 30: Control unit mcp@2

Control unit	mcp@2 with frequency converter
Size	380 x 380 x 210 mm
Housing	Steel (V2A on request) Colour: RAL 7035
Protection type	IP65
Viewing window for display screen	Display for status and fault messages
Operating controls	Operating panel for operation and parameterisation of the door system Master switch
Supply voltage	L/N/PE 230 V +/- 10% or 3~L/N/PE 400 V +/- 10%
Frequency	50–60 Hz
Supply cable	Fuse protection of 16 A to be provided by the user (K characteristic)
With residual-current circuit breaker (RCCD) as necessary	300 mA as per DIN VDE 0100-530 (AC/DC sensitive)

Construction of the high-speed spiral door

EFA-CON® Industrial control unit

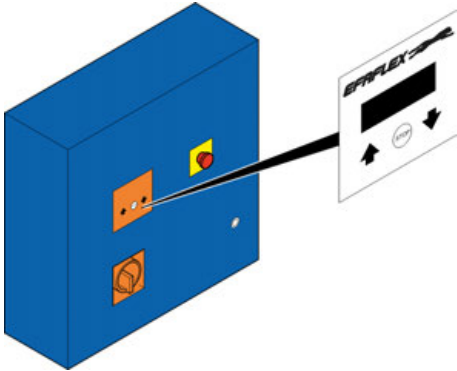

Fig. 31: EFA-CON® Industrial

Control unit	EFA-CON® with frequency converter
Size	380 x 380 x 210 mm
Housing	Steel (V2A on request) Colour: RAL 7035
Protection type	IP65
Viewing window for display screen	Display for status and fault messages
Operating controls	Operating panel for operation and parameterisation of the door system Master switch
Supply voltage	L/N/PE 230 V +/- 10%
Frequency	50–60 Hz
Supply cable	Fuse protection of 16 A to be provided by the user (K characteristic)
With residual-current circuit breaker (RCCD) as necessary	300 mA as per DIN VDE 0100-530 (AC/DC sensitive)

4 Door safety

Safety edge and light barrier

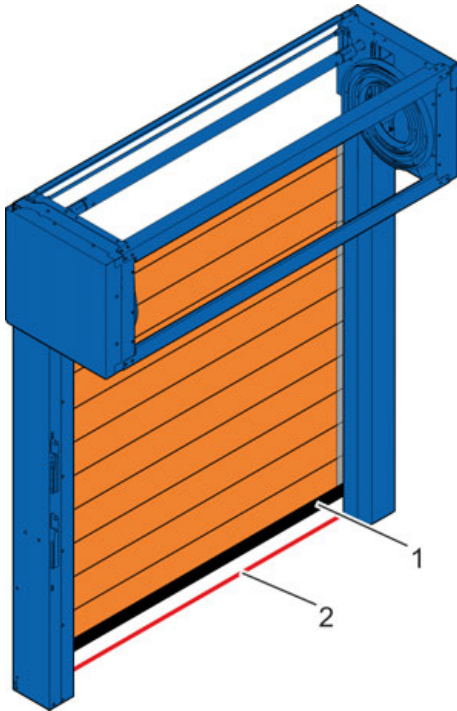

Fig. 32: Safety edge and light barrier

The main closing edge is secured by a combination of a safety edge and light barrier (C device plus D device). This achieves the minimum protection level as per EN 12453.

If the safety edge of the door system comes into contact with an obstruction during the closing procedure, the door leaf stops, the door system opens completely and closes automatically again once the "keep-open" time has elapsed.

The safety edge complies with the requirements of the product standard for doors DIN EN 13241-1. In addition, the owner and the manufacturer have to consult with each other in order to provide a safeguard for the approach area. This will be based on the owner's risk assessment.

The light barriers (max. 2, IP 67) which are installed in the side frames at the sides are positioned directly at the door closing level. The height of the light barriers is variable.

Door light grid

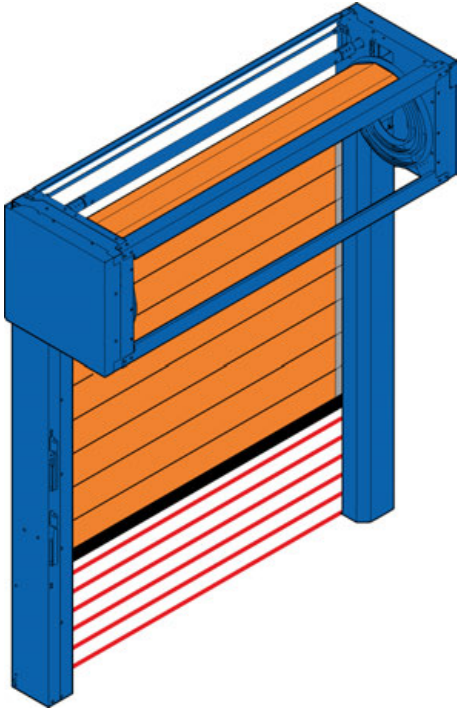

Fig. 33: Door light grid

The door light grid (IP 67) which is installed in the side of the side frames monitors the closing level exactly, up to a height of 2.5 metres. The door light grid prevents the door system from closing when an obstruction is detected.

Door light grid – certified safety system (BWS 2) as per EN 12978 and EN 61496 – for door system heights according to the respective technical properties (☞ *Technical properties* on page 6); lower heights approved on an individual basis.

Simultaneous installation of a door light grid and light barrier is not possible.

5 Equipment

Standard equipment

- Basic door construction, galvanised (275 g/m²)
- Round spiral door leaf guide (278, 304)
- Low lintel door leaf guide (281)
- Aluminium lath, 105 mm x 20 mm (278, 281) or 105 mm x 30 mm (304)
- EFA-TRONIC® control unit
- Safety edge

Optional equipment (special equipment subject to surcharge)

- Basic door construction, galvanised (275 g/m²), with powder-coated finish as per RAL
- Basic stainless steel (V2A 1.4301) door construction, corrosion resistant, ground (grain 220)
- Sight lath with SAN glass, 105 mm x 20 mm (278, 281) or 105 x 30 mm (304)
- Sight lath with polycarbonate glass (scratch resistant surface), 105 mm x 20 mm (278/281)
- Ventilation lath, 105 mm x 20 mm (278, 281) or 105 x 30 mm (304)
- Door leaf laths with powder coated finish with RAL colour
- Mcp2 control unit in steel control cabinet
- Mcp2 control unit in V2A control cabinet
- EFA-CON® Industrial control unit in steel control cabinet
- EFA-CON® Industrial control unit in V2A control cabinet
- EFA-TRONIC® control unit in steel control cabinet
- EFA-TRONIC® control unit in V2A control cabinet
- Door light grid
- Up to 2 safety light barriers
- Command devices: Push-buttons, pull switches, key switches etc.
- Command devices/safety: Radar detector, EFA-SCAN®, IR (infrared presence sensor)
- Complete spiral console cover (278, 304)
- Spiral console bottom cover (281)
- Locking mechanism
- Locking mechanism which can be shut off
- Side frame extension on both sides
- "Door open" limit switch, roller lever limit switch type
- "Intermediate stop" limit switch, type Pepperl and Fuchs NJ 15
- "Door closed" limit switch, Schmersal roller lever limit switch type, Euchner CES safety limit switch, Pepperl and Fuchs NJ 15

Special constructions

Special constructions/special orders are design types which are not covered, either mechanically or electrically, by standard versions in the sales price lists or by a design from the technology variants table. They have to be requested specifically. Surcharges and extended delivery times are calculated for special designs in accordance with the actual expenditure.

6 Packaging units

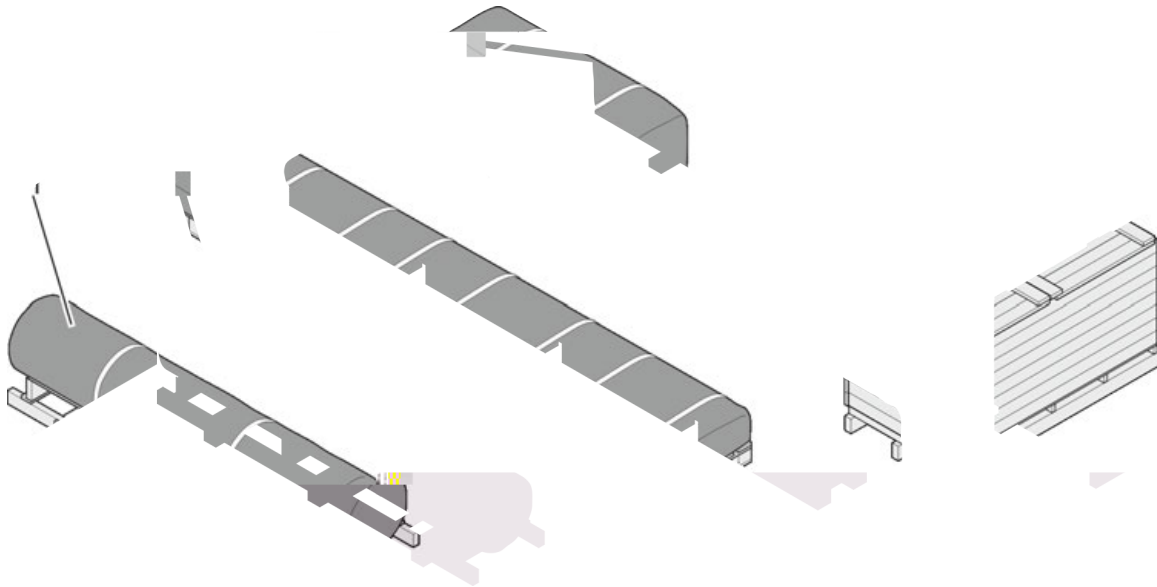

Fig. 34: Scope of delivery (standard transport units)

- | | | | |
|---|--|---|--|
| 1 | Transport unit 1 (example): Door leaf package ("low lintel" version only) | 3 | Transport unit 3 (example): Spiral console with door leaf, drive |
| 2 | Transport unit 2 (example): Side frames with covers, control unit, accessories | 4 | Wooden crate (optional) |

Number of transport units

The number of transport units depends on the selected configuration.

The transport units can also be delivered in a wooden crate. The number of wooden crates depends on the dimensions of the standard transport units.

The wood for the wooden crates complies with the IPPC standard. The wooden crates are lined with film to protect them from moisture and are thus suitable for sea freight.

Packages which are fastened to pallets can be transported by fork lift under the following conditions:

- The fork lift must have the appropriate capacity for the weight of the packages.
- The package must be securely fastened to the pallet.
- The fork lift driver must be authorised to drive industrial trucks with a driver's seat or driver's station in accordance with the local regulations.

The transport units are not stackable.



EFAFLEX Tor- und Sicherheitssysteme

GmbH & Co. KG

Fliederstraße 14

84079 Bruckberg

Germany

Telephone: + 49 8765 82-0

Fax: + 49 8765 82-200

email: info@efaflex.com

Internet: www.efaflex.com