

## Spare Parts Overview

**Valid from 01.03.2026**

# High-speed doors [2 / 3]

Doors with fixed door leaf

High-quality wet coating

Controls

Light grille cable concept

Accessories for operators and controls

# Hörmann international sales companies and distribution partners

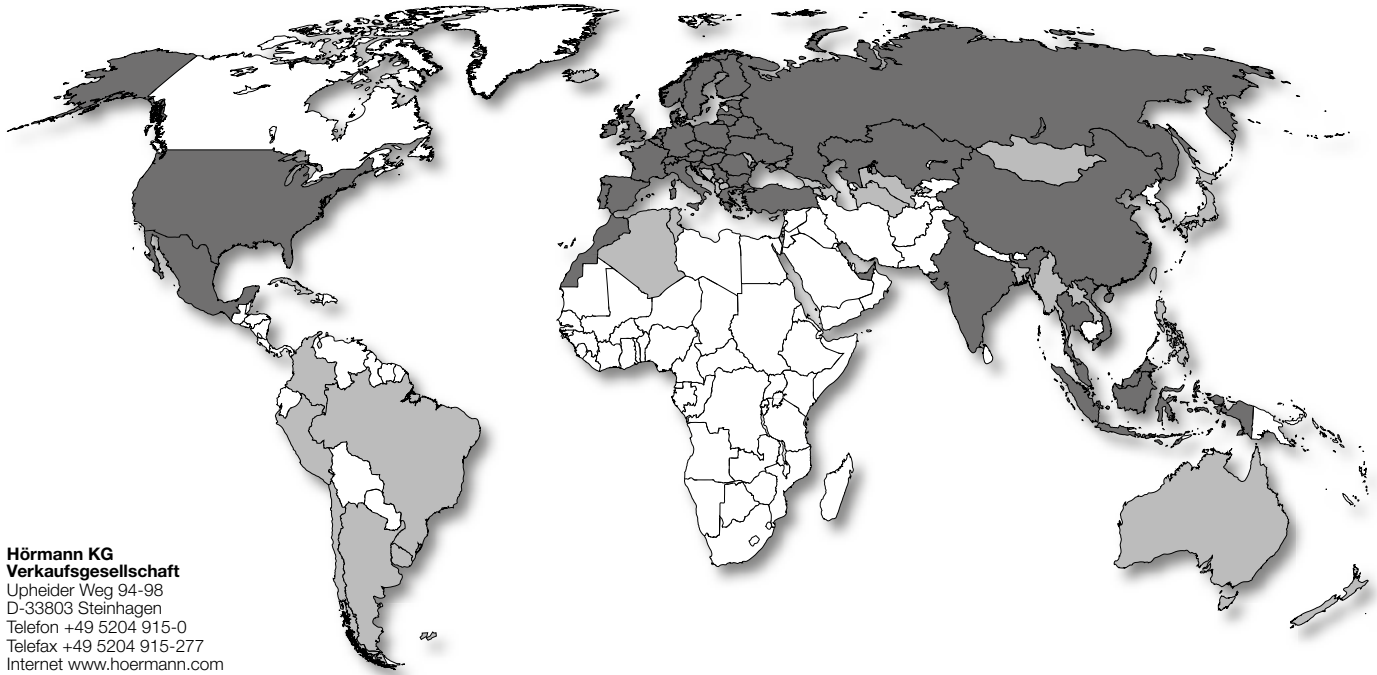

**Hörmann KG  
Verkaufsgesellschaft**  
Upheider Weg 94-98  
D-33803 Steinhagen  
Telefon +49 5204 915-0  
Telefax +49 5204 915-277  
Internet [www.hoermann.com](http://www.hoermann.com)

**Hörmann international sales companies**

**International distribution partners**

## Hörmann international sales companies

**Hörmann Austria**  
A-5310 Mondsee  
[info@hoermann.at](mailto:info@hoermann.at)

**Hörmann Baltic**  
LT-14247 Vilnius r.  
[info@hoermann.lt](mailto:info@hoermann.lt)  
LV-2167 Marupe  
[info@hoermann.lv](mailto:info@hoermann.lv)

**Hörmann Bel**  
BY-220125 Minsk  
[info@hoermann.by](mailto:info@hoermann.by)

**Hörmann Belgium**  
B-3700 Tongeren  
[info@hoermann.be](mailto:info@hoermann.be)

**Hörmann Bulgaria**  
BG-1532 Sofia  
[info.sof@hoermann.bg](mailto:info.sof@hoermann.bg)

**Hörmann Česká republika**  
CZ-252 68 Středokluky  
[info@hoermann.cz](mailto:info@hoermann.cz)

**Hörmann China**  
CN-100176 Beijing  
[sales.tjn@hoermann.cn](mailto:sales.tjn@hoermann.cn)

**Hörmann Danmark**  
DK-8940 Randers  
[info@hoermann.dk](mailto:info@hoermann.dk)

**Hörmann Eesti**  
EST-76505 Saue  
[info.tll@hoermann.ee](mailto:info.tll@hoermann.ee)

**Hörmann España**  
E-08228 Terrassa  
[info@hoermann.es](mailto:info@hoermann.es)

**Mesvac Oy**  
FI-02420 Jorvas  
[myynti@mesvac.fi](mailto:myynti@mesvac.fi)

**Hörmann France**  
F-89102 Sens Cedex  
[info@hoermann.fr](mailto:info@hoermann.fr)

**Hörmann Hellas**  
GR-19400 Koropi  
[info@hoermann.gr](mailto:info@hoermann.gr)

**Hörmann Hong Kong**  
HK-Quarry Bay  
[info@hoermann.com.hk](mailto:info@hoermann.com.hk)

**Hörmann Hrvatska**  
HR-10290 Zaprešić  
[info@hoermann.hr](mailto:info@hoermann.hr)

**Hörmann Hungaria**  
H-2310 Szigetszentmiklós  
[info@hoermann.hu](mailto:info@hoermann.hu)

**Hörmann Indien**  
Shakti Hormann  
IND-500 043 Hyderabad,  
Telangana  
[sales@shaktihormann.com](mailto:sales@shaktihormann.com)

**Hörmann Indonesia**  
ID-12520 Jakarta  
[info@hoermann.id](mailto:info@hoermann.id)

**Hörmann Dock & Door Ltd.**  
IRL-W23 E6TX Kildare  
[info@hoermann.ie](mailto:info@hoermann.ie)

**Hörmann Italia**  
I-38015 Lavis (Trento)  
[info@hoermann.it](mailto:info@hoermann.it)

**Hörmann Kazakhstan**  
KZ-050019 Almaty  
[info@hoermann.kz](mailto:info@hoermann.kz)

**Hörmann Maghreb**  
MA-28810 Mohammedia  
[info@hoermann.ma](mailto:info@hoermann.ma)

**Hörmann Malaysia**  
MAL-40150 Shah Alam,  
Selangor  
[info\\_apac@hoermann.com](mailto:info_apac@hoermann.com)

**Hörmann Mexico**  
MEX-66350  
Santa Catarina  
[info@hoermann.com.mx](mailto:info@hoermann.com.mx)

**Hörmann Middle East & Africa**  
UAE-Dubai  
[info.dxb@hoermann.com](mailto:info.dxb@hoermann.com)

**Hörmann Nederland**  
NL-7324 CV Apeldoorn  
[info@hoermann.nl](mailto:info@hoermann.nl)

**Hörmann Norge**  
N-4640 Søgne  
[info@hoermann.no](mailto:info@hoermann.no)

**Hörmann Polska**  
PL-62-052 Komorniki  
[info@hoermann.pl](mailto:info@hoermann.pl)

**Hörmann Portugal**  
P-2710-297 Sintra  
[info@hoermann.pt](mailto:info@hoermann.pt)

**Hörmann Romania**  
RO-077040, Chiajna,  
Județul Ilfov  
[info@hoermann.ro](mailto:info@hoermann.ro)

**Hörmann Russia**  
RUS-196626  
Sankt Petersburg  
[info@hoermann.ru](mailto:info@hoermann.ru)

**Hörmann Schweiz**  
CH-4702 Oensingen  
[info@hoermann.ch](mailto:info@hoermann.ch)

**Hörmann Serbia**  
SRB-11272  
Beograd-Dobanovci  
[info@hoermann.rs](mailto:info@hoermann.rs)

**Hörmann Slovenija**  
SI-3301 Petrovče  
[info@hoermann.si](mailto:info@hoermann.si)

**Hörmann Slovenská republika**  
SK-903 01 Senec  
[info.bts@hoermann.com](mailto:info.bts@hoermann.com)

**Hörmann Svenska**  
S-70369 Örebro  
[info@hoermann.se](mailto:info@hoermann.se)

**Hörmann Thailand**  
TH-Bangplee,  
Samutprakarn 10540  
[info@hoermann.co.th](mailto:info@hoermann.co.th)

**Hörmann Türkiye**  
TR-34870 Kartal – Istanbul  
[info.ist@hoermann.com.tr](mailto:info.ist@hoermann.com.tr)

**Hörmann UK**  
GB-Leicestershire  
LE67 4JW  
[info@hoermann.co.uk](mailto:info@hoermann.co.uk)

**Hörmann Ukraine**  
UA-08300 Boryspil,  
Kyivska Obl.  
[info@hoermann.com.ua](mailto:info@hoermann.com.ua)

**Hörmann Group Americas**  
USA-Sparta,  
TN 38583  
[info@hoermann.us](mailto:info@hoermann.us)

**Hörmann Vietnam**  
VN-Hanoi  
[info.han@hoermann.vn](mailto:info.han@hoermann.vn)

## International distribution partners

Albania  
Algeria  
Argentina  
Armenia  
Australasia  
Azerbaijan  
Balearic Islands

Bangladesh  
Bosnia-Herzegovina  
Brazil  
Cambodia  
Canary Islands  
Chile  
Colombia

Cuba  
Cyprus  
Georgia  
Iceland  
Israel  
Japan  
Kosovo

Laos  
Luxembourg  
Malta  
Moldova  
Mongolia  
Montenegro  
Myanmar

New Zealand  
North Macedonia  
Peru  
South Korea  
Taiwan  
The Philippines  
Tunisia

Turkmenistan  
Uruguay  
Uzbekistan

For more information on our sales companies and sales partners, visit [www.hoermann.com](http://www.hoermann.com).

Our General terms and conditions of sale and delivery valid at the time of the order apply.  
The current version of our General terms and conditions of sale and delivery is available on our website: [www.hoermann.com/en/gtc](http://www.hoermann.com/en/gtc)

Prices in €. Copyright. No part of this price list may be reproduced without our permission. All details subject to change.



# Table of contents

■ Overview of data label	5
■ Wearing parts	6
■ HS 7030 PU	7
■ 1. High-Speed Door HS 7030 PU	8
■ HS 5015 PU N	17
■ 2. High-Speed Door HS 5015 PU N	18
■ HS 5015 PU H	27
■ 3. High-Speed Door HS 5015 PU H	28
■ HS 6015 PU V	36
■ 4. High-Speed Door HS 6015 PU V	37
■ HS 7030 PU 42	45
■ 5. High-Speed Door HS 7030 PU 42	46
■ HS 5015 PU N 42	60
■ 6. High-Speed Door HS 5015 PU N 42	61
■ HS 5015 PU H 42	70
■ 7. High-Speed Door HS 5015 PU H 42	71
■ HS 6015 PU V 42	80
■ 8. High-Speed Door HS 6015 PU V 42	81
■ HS 5012 PU 42 S	89
■ 9. High-Speed Door HS 5012 PU 42 S	90
■ HS 5015 PU H 67	102
■ 10. High-Speed Door HS 5015 PU H 67	103
■ HS 6015 PU V 67	111
■ 11. High-Speed Door HS 6015 PU V 67	112







# Table of contents

■ HS 5015 Acoustic H	120
■ 12. High-speed door HS 5015 Acoustic H	121
■ IsoSpeed Cold H 100	130
■ 13. High-speed door IsoSpeed Cold H 100	131
■ IsoSpeed Cold V 100	140
■ 14. High-speed door IsoSpeed Cold V 100	141
■ HS 5040 TurboLux (S)	149
■ 15. High-speed door HS 5040 TurboLux (S)	150
■ HS 5015 PU N 42 S	164
■ 16. High-speed door HS 5015 PU N 42 S	165
■ 17. High-quality wet coating	173
■ 18. 1-phase / 3-phase controls, SmartControl	174
■ 19. Light grille cable concept	176
■ 20. Accessories for operators and controls	179
■ Spare parts order form	187

## Symbols used

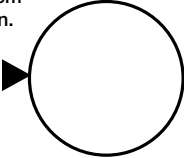
Symbol	Description
	Price on request
	Please note the extended delivery times
	Prices marked with a dot indicate articles that <b>are available from stock</b> and available immediately ex works.

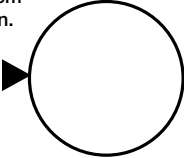
# Overview of data label

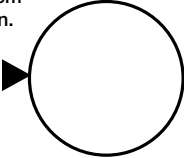
<b>DEUTSCH</b>	<b>Bei Ersatzbestellung:</b> Vom Typenschild, Tortyp: ①, Seriennummer: ②, Erklärung: <b>0410 - 00900320010101</b> = feststehende Werknummer <b>0410 - 00900320010101</b> = Werksauftragsnummer <b>0410 - 00900320010101</b> = Torpositionsnummer <b>0410 - 00900320010101</b> = Tor 1 aus der Torpositionsnummer Baujahr: ③ Größe: ④, zusammen mit der Artikelnummer des Ersatzteils angeben.	<table border="1"> <tr> <td>Hersteller Manufacturer Fabricant</td> <td colspan="2"><b>Hörmann VKG</b> <b>D-33803 Steinhagen</b> <b>Upheider Weg 94-98</b> <b>Made in Germany</b></td> </tr> <tr> <td>Tor Typ Door type Type de port</td> <td><b>V5030SEL</b></td> <td>①</td> </tr> <tr> <td>Seriennummer Serial No N° de Série</td> <td><b>0410-00900320010101</b></td> <td>②</td> </tr> <tr> <td>Baujahr Year of product Année de fabrication</td> <td><b>2015</b></td> <td>③</td> </tr> <tr> <td>Größe Size Dimensions</td> <td><b>3750 x 3500</b></td> <td>④</td> </tr> <tr> <td>Wasserdichtheit Water tightness Étanchéité à l'eau</td> <td>Klasse Class Classe</td> <td><b>NPD</b></td> </tr> <tr> <td>Widerstand geg. Windlast Resistance to wind load Résistance à la charge du vent</td> <td>Klasse Class Classe</td> <td><b>NPD</b></td> </tr> <tr> <td>Wärmewiderstand Thermal resistance Résistance thermique</td> <td>W/m²K</td> <td><b>NPD</b></td> </tr> <tr> <td>Luftdurchlässigkeit Air permeability Perméabilité à l'air</td> <td>Klasse Class Classe</td> <td><b>NPD</b></td> </tr> <tr> <td colspan="3" style="text-align: center;">  <b>EN 13241</b> </td> </tr> <tr> <td colspan="3">         Diese Anlage wurde gemäß der technischen Regel für Arbeitsstätten ASR A 1.7 sachkundig geprüft. Die Durchführung und das Ergebnis der Prüfung ist dem Prüfprotokoll zu entnehmen.       </td> </tr> <tr> <td colspan="2">          Nächster Prüftermin       </td> <td>  </td> </tr> </table>	Hersteller Manufacturer Fabricant	<b>Hörmann VKG</b> <b>D-33803 Steinhagen</b> <b>Upheider Weg 94-98</b> <b>Made in Germany</b>		Tor Typ Door type Type de port	<b>V5030SEL</b>	①	Seriennummer Serial No N° de Série	<b>0410-00900320010101</b>	②	Baujahr Year of product Année de fabrication	<b>2015</b>	③	Größe Size Dimensions	<b>3750 x 3500</b>	④	Wasserdichtheit Water tightness Étanchéité à l'eau	Klasse Class Classe	<b>NPD</b>	Widerstand geg. Windlast Resistance to wind load Résistance à la charge du vent	Klasse Class Classe	<b>NPD</b>	Wärmewiderstand Thermal resistance Résistance thermique	W/m²K	<b>NPD</b>	Luftdurchlässigkeit Air permeability Perméabilité à l'air	Klasse Class Classe	<b>NPD</b>	 <b>EN 13241</b>			Diese Anlage wurde gemäß der technischen Regel für Arbeitsstätten ASR A 1.7 sachkundig geprüft. Die Durchführung und das Ergebnis der Prüfung ist dem Prüfprotokoll zu entnehmen.			 Nächster Prüftermin		
Hersteller Manufacturer Fabricant	<b>Hörmann VKG</b> <b>D-33803 Steinhagen</b> <b>Upheider Weg 94-98</b> <b>Made in Germany</b>																																					
Tor Typ Door type Type de port	<b>V5030SEL</b>		①																																			
Seriennummer Serial No N° de Série	<b>0410-00900320010101</b>		②																																			
Baujahr Year of product Année de fabrication	<b>2015</b>		③																																			
Größe Size Dimensions	<b>3750 x 3500</b>	④																																				
Wasserdichtheit Water tightness Étanchéité à l'eau	Klasse Class Classe	<b>NPD</b>																																				
Widerstand geg. Windlast Resistance to wind load Résistance à la charge du vent	Klasse Class Classe	<b>NPD</b>																																				
Wärmewiderstand Thermal resistance Résistance thermique	W/m²K	<b>NPD</b>																																				
Luftdurchlässigkeit Air permeability Perméabilité à l'air	Klasse Class Classe	<b>NPD</b>																																				
 <b>EN 13241</b>																																						
Diese Anlage wurde gemäß der technischen Regel für Arbeitsstätten ASR A 1.7 sachkundig geprüft. Die Durchführung und das Ergebnis der Prüfung ist dem Prüfprotokoll zu entnehmen.																																						
 Nächster Prüftermin																																						
<b>ENGLISH</b>	<b>For spare part order:</b> From data label, door type: ①, serial number: ②, Explanation: <b>0410 - 00900320010101</b> = permanent factory number <b>0410 - 00900320010101</b> = factory order number <b>0410 - 00900320010101</b> = door item number <b>0410 - 00900320010101</b> = door 1 from the door item number Year of manufacture: ③ size: ④, indicate along with the article number of the spare part.																																					
<b>FRANÇAIS</b>	<b>Lors de la commande de pièces détachées :</b> A partir de la plaque d'identification, indiquez le type de porte : ①, le numéro de série : ②, explication : <b>0410 - 00900320010101</b> = numéro de fabrication fixe <b>0410 - 00900320010101</b> = numéro de commande usine <b>0410 - 00900320010101</b> = numéro de poste de la porte <b>0410 - 00900320010101</b> = porte 1 sur nombre total de postes de porte l'année de construction : ③ et les dimensions : ④, ainsi que le numéro d'article de la pièce détachée.																																					
<b>ESPAÑOL</b>	<b>Para pedidos de recambios:</b> De la placa de características, tipo de puerta: ①, n.º de serie: ②, explicación: <b>0410 - 00900320010101</b> = número fijo de fábrica <b>0410 - 00900320010101</b> = número de orden de fábrica <b>0410 - 00900320010101</b> = número de posición de la puerta <b>0410 - 00900320010101</b> = puerta 1 del número de posición de la puerta Indicar año de construcción: ③ y tamaño: ④, junto con el número de artículo del recambio.																																					
<b>РУССКИЙ</b>	<b>При заказе запасных частей:</b> На заводской табличке, тип ворот: ①, серийный номер: ②, Пояснение: <b>0410 - 00900320010101</b> = постоянный номер завода <b>0410 - 00900320010101</b> = номер заказа с завода <b>0410 - 00900320010101</b> = номер позиции ворот <b>0410 - 00900320010101</b> = ворота 1 из номера позиции ворот Год изготовления: ③ размер: ④, указать вместе с номером артикула запасной части.																																					

# Wearing parts

Verschleißteile	Zyklen	Zeitraum
Antrieb HS 5040 TurboLux (S) <sup>2)</sup>	1 000 000	2 Jahre
Rohrmotor (V 4020 SEL Alu-R) <sup>1)</sup>	1 500 000	
Rohrmotor (V 4020 Protect / Cold / RFID) <sup>1)</sup>	2 500 000	
Antrieb V 5025 Z <sup>1)</sup>	1 000 000	
Antrieb (60 % ED)	500 000	
Bremse	250 000	
FunkCrash-Schalterbatterie	-/-	
Energiekette mit Kabel	250 000	
Federn <sup>3)</sup>	100 000	
Gewebegurte	100 000	
Flachriemen (Gegengewicht / Torblatt, Federn TurboLux)	500 000	
Gummiseil <sup>3)</sup>	100 000	
Laufrollen	250 000	
Gleiter (Gegengewicht / Torblatt / Federn)	100 000	
USV-Batterie	-/-	
USV-Batterie (RW-Tore)	-/-	1 Jahre
Scharniere	250 000	2 Jahre
Dichtungen, Dichtleisten	150 000	

- 1) zwingender Tausch der Bauteile bei den o. g. Zyklen
- 2) zwingender Tausch der Bremse bei den o. g. Zyklen
- 3) Tausch der Bauteile bei den o.g. Zyklen empfohlen (außer Stützfedern für Doppelrollen)

Wearing parts	Cycles	Period
Operator HS 5040 TurboLux (S) <sup>2)</sup>	1 000 000	2 Years
Tubular drive (V 4020 SEL Alu-R) <sup>1)</sup>	1 500 000	
Tubular drive (V 4020 Protect / Cold / RFID) <sup>1)</sup>	2 500 000	
Operator V 5025 Z <sup>1)</sup>	1 000 000	
Operator (60% ON time)	500 000	
Brake	250 000	
Radio crash switch battery	-/-	
Energy chain with cable	250 000	
Springs <sup>3)</sup>	100 000	
Fabric belts	100 000	
Flat belt (counter weight / door leaf, springs TurboLux)	500 000	
Rubber cord <sup>3)</sup>	100 000	
Rollers	250 000	
Glider (counter weight / door leaf / springs)	100 000	
UPS battery	-/-	
UPS battery (RW doors)	-/-	1 year
Hinges	250 000	2 Years
Seals, sealing strips	150 000	

- 1) Compulsory replacement of the components in the above-mentioned cycles
- 2) Compulsory replacement of the brake in the above-mentioned cycles
- 3) Component replacement recommended for the aforementioned cycles (excluding supporting springs for double castors)

Pièces d'usure	Cycles	Intervalle
Motorisation HS 5040 TurboLux (S) <sup>2)</sup>	1 000 000	2 ans
Moteur tubulaire (V 4020 SEL Alu-R) <sup>1)</sup>	1 500 000	
Moteur tubulaire (V 4020 Protect / Cold / RFID) <sup>1)</sup>	2 500 000	
Motorisation V 5025 Z <sup>1)</sup>	1 000 000	
Motorisation (durée de mise en marche 60%)	500 000	
Frein	250 000	
Batterie interrupteur anticrash radio	-/-	
Chaîne de puissance avec câble	250 000	
Ressorts <sup>3)</sup>	100 000	
Bandes en tissu	100 000	
Courroie plate (contrepois / tablier de porte, ressorts TurboLux)	500 000	
Tendeur <sup>3)</sup>	100 000	
Galets de guidage	250 000	
Patins (contrepois / tablier de porte / ressorts)	100 000	
Batterie UPS	-/-	
Batterie UPS (portes RW)	-/-	1 an
Charnières	250 000	2 ans
Joints, listels d'étanchéité	150 000	

- 1) Remplacement obligatoire des composants pour les cycles mentionnés plus haut
- 2) Remplacement obligatoire du frein pour les cycles mentionnés plus haut
- 3) Remplacement recommandé des composants pour les cycles mentionnés plus haut (sauf ressorts de soutien pour galets doubles)

Piezas de desgaste	Ciclos	Intervalo de tiempo
Automatismo HS 5040 TurboLux (S) <sup>2)</sup>	1 000 000	2 años
Motor tubular (V 4020 SEL Alu-R) <sup>1)</sup>	1 500 000	
Motor tubular (V 4020 Protect / Cold / RFID) <sup>1)</sup>	2 500 000	
Automatismo V 5025 Z <sup>1)</sup>	1 000 000	
Automatismo (60% ED)	500 000	
Freno	250 000	
Batería del conmutador del choque por radio	-/-	
Cadena energética con cable	250 000	
Muelles <sup>3)</sup>	100 000	
Correas de tejido	100 000	
Correa plana (contrapeso / hoja de puerta, muelles TurboLux)	500 000	
Cuerda elástica <sup>3)</sup>	100 000	
Ruedas-guía	250 000	
Deslizador (contrapeso / hoja de puerta / muelles)	100 000	
Batería USV	-/-	
Batería USV (puerta RW)	-/-	1 año
Bisagras	250 000	2 años
Juntas, labios de sellado	150 000	

- 1) cambio obligatorio de los componentes en los ciclos nombrados arriba
- 2) cambio obligatorio del freno en los ciclos nombrados arriba
- 3) Cambio recomendado de los componentes en los ciclos nombrados arriba (excepto muelles de apoyo para ruedas dobles)

# HS 7030 PU

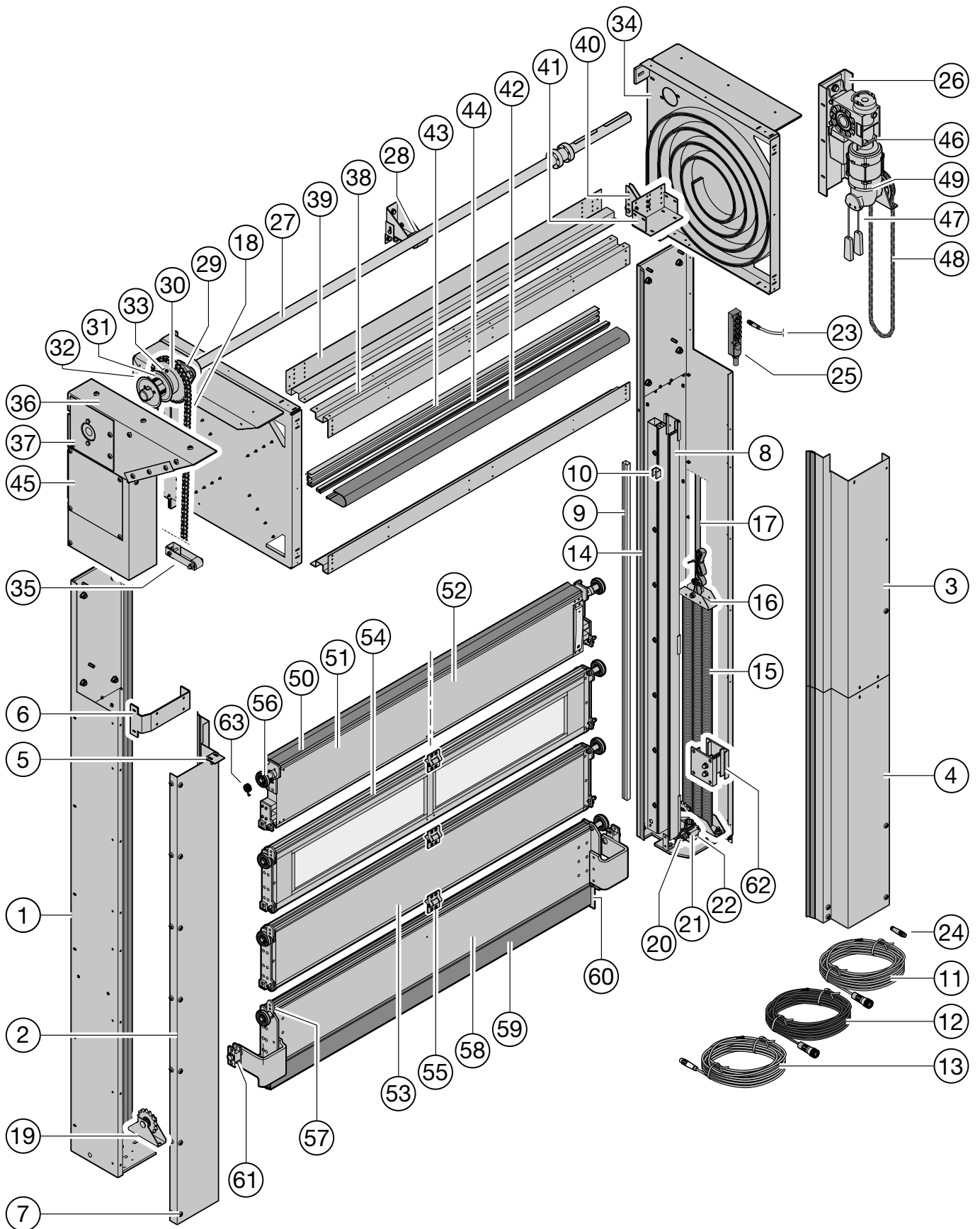



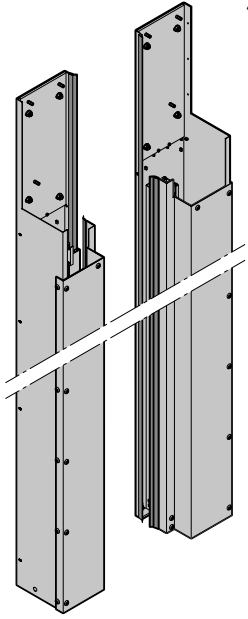
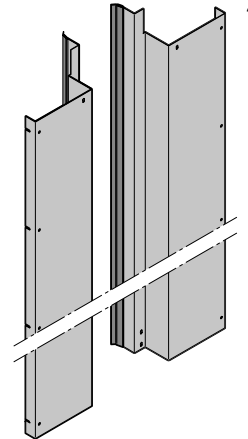
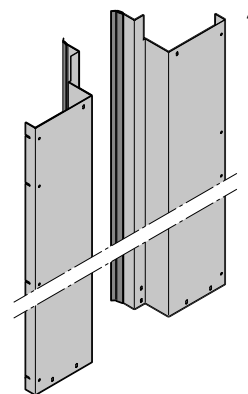

# 1. High-Speed Door HS 7030 PU

Article	Item	Description	Production period	Art. no.	Quantity	€
	*	<b>1.1 Side element</b>			Unit(s)	
		Right	01.03.2011 – 31.12.2015	4990890	_____	/ each
		Left	01.03.2011 – 31.12.2015	4990896	_____	/ each
	*	<b>1.2 Cover, 1-part, LDH ≥ 3250 mm</b>			Unit(s)	
		Right	01.03.2011 – 31.12.2015	4991900	_____	/ m / each
		Left	01.03.2011 – 31.12.2015	4991901	_____	/ m / each
	*	<b>1.3 Top cover, 2-part, LDH &gt; 3250 mm</b>			Unit(s)	
		Right	01.03.2011 – 31.12.2015	4991876	_____	/ m / each
		Left	01.03.2011 – 31.12.2015	4991902	_____	/ m / each

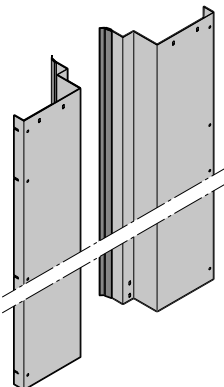

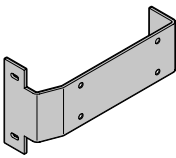
\* State purchase order number  
 Surcharge for high-quality wet coating panel (see page 173)

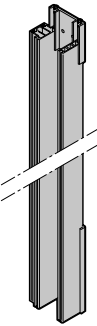
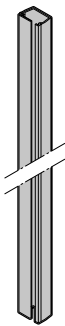
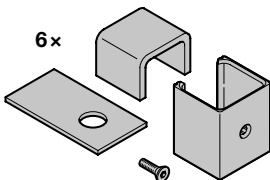
# 1. High-Speed Door HS 7030 PU

Article	Item	Description	Production period	Art. no.	Quantity	€
	*	<b>1.4 Bottom cover, 2-part, LDH &gt; 3250 mm</b>			Unit(s)	
	Right		01.03.2011 – 31.12.2015	4990803	_____	/ m
	Left		01.03.2011 – 31.12.2015	4990806	_____	/ m
	<b>1.5</b>	<b>Cover support bracket</b>	01.03.2011 – 31.12.2015	4990831	Unit(s) _____	/ each
	<b>1.6</b>	<b>Cover bar</b>	01.03.2011 – 31.12.2015	4990830	Unit(s) _____	/ each
 50x	<b>1.7</b>	<b>Self-tapping screws M6 x 12</b> Screws for cover		4992181	Unit(s) _____	/ each
	*	<b>1.8 Complete aluminium profile guide</b>			Unit(s)	
	Right		01.03.2011 – 31.12.2015	4990816	_____	/ m
	Left		01.03.2011 – 31.12.2015	4990817	_____	/ m
	*	<b>1.9 Light grille</b> For article numbers and lengths see pages 176 – 178 light grille / cable concept	01.03.2011 – 31.12.2015		Unit(s) _____	/ each
 6x	<b>1.10</b>	<b>Holder for light grille</b>	01.03.2011 – 31.12.2015	4981440	Unit(s) _____	/ each

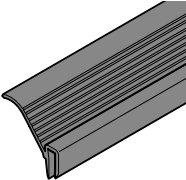
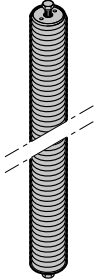
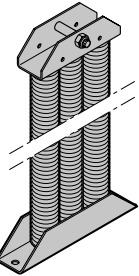
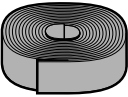

\* State purchase order number  
Surcharge for high-quality wet coating panel (see page 173)

# 1. High-Speed Door HS 7030 PU

Article	Item	Description	Production period	Art. no.	Quantity	€
	<b>1.11</b>	<b>Cable, light grille, grey, 15 m</b> Receiver always fitted on left, only FUEH	01.03.2011 – 31.05.2015	4990759	Unit(s) _____	/ each
	<b>1.12</b>	<b>Cable, light grille, black, 15 m</b> Transmitter always fitted on right, only FUEH	01.03.2011 – 31.05.2015	4990760	Unit(s) _____	/ each
	*	<b>1.13 Snap cable, white, light grille</b> For article numbers and lengths see pages 176 – 178 light grille / cable concept	01.06.2015 – 31.12.2015		Unit(s) _____	/ each
	*	<b>1.14 Seal for guide</b> Additional 2 × per side element required  4000 mm 5000 mm 6000 mm	01.03.2011 – 31.12.2015 01.03.2011 – 31.12.2015 01.03.2011 – 31.12.2015	4991585 4991586 4991490	Unit(s) _____ _____ _____	/ each / each / each
	*	<b>1.15 Single spring</b>	01.03.2011 – 31.12.2015		Unit(s) _____	/ each
	*	<b>1.16 Complete spring assembly</b>  Right Left	01.03.2011 – 31.05.2015 01.03.2011 – 31.05.2015		Unit(s) _____ _____	/ each / each
	*	<b>1.17 Belt</b>  3950 mm 5200 mm 7200 mm LDH + 300 mm serves as a calculation aid	01.01.2016 – 01.01.2016 – 01.01.2016 –	4990496 4990495 4990494	Unit(s) _____ _____ _____	/ each / each / each



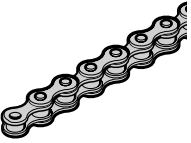
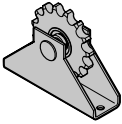
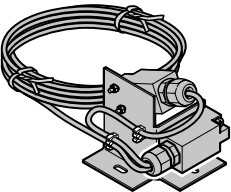
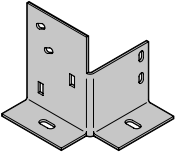

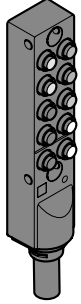
\* State purchase order number  
Surcharge for high-quality wet coating panel (see page 173)

# 1. High-Speed Door HS 7030 PU

Article	Item	Description	Production period	Art. no.	Quantity	€
	*	<b>1.18 Roller chain reinforced</b>	01.03.2011 – 31.12.2015	159568	m	/ m
		<b>1.19 Complete chain tensioner wheel</b>			Unit(s)	
		Right	01.03.2011 – 31.12.2015	4990809	_____	/ each
		Left	01.03.2011 – 31.12.2015	4990810	_____	/ each
		<b>1.20 Button with wiring</b>			Unit(s)	
		For spring and chain monitoring				
		Right	01.03.2011 – 31.05.2015	4990812	_____	/ each
			01.06.2015 – 31.12.2015	4980327	_____	/ each
		Left	01.03.2011 – 31.05.2015	4990813	_____	/ each
			01.06.2015 – 31.12.2015	4980337	_____	/ each
		<b>1.21 Chain test button</b>			Unit(s)	
		For chain monitoring				
		Right	01.03.2011 – 31.05.2015	4991156	_____	/ each
			01.06.2015 – 31.12.2015	4992012	_____	/ each
		Left	01.03.2011 – 31.05.2015	4991155	_____	/ each
			01.06.2015 – 31.12.2015	4992011	_____	/ each
		<b>1.22 Button support</b>			Unit(s)	
		Right	01.03.2011 – 31.12.2015	4991130	_____	/ each
		Left	01.03.2011 – 31.12.2015	4991131	_____	/ each
	*	<b>1.23 Snap cable blue, spring / counter weight</b>	01.06.2015 – 31.12.2015		Unit(s)	/ each
		For article numbers and lengths see pages 176 – 178 light grille / cable concept				
		<b>1.24 Bridge plug snap8</b>	01.06.2015 – 31.12.2015	4980188	Unit(s)	/ each
	*	<b>1.25 Distributor 10 x M8 snap</b>	01.06.2015 – 31.12.2015		Unit(s)	/ each
		For article numbers and lengths see pages 176 – 178 light grille / cable concept				

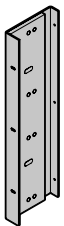
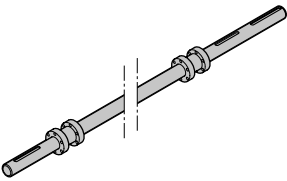
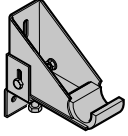
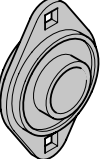
\* State purchase order number  
Surcharge for high-quality wet coating panel (see page 173)

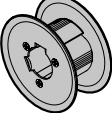
# 1. High-Speed Door HS 7030 PU

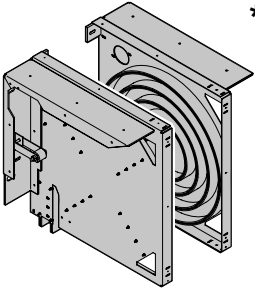
Article	Item	Description	Production period	Art. no.	Quantity	€
	1.26	Complete operator support bracket	01.03.2011 – 31.12.2015	4990800	Unit(s) _____	/ each
	1.27	Complete shaft	01.03.2011 – 31.12.2015	4990841	Unit(s) _____	/ m / each
	1.28	Shaft support complete	01.03.2011 – 31.12.2015	4990877	Unit(s) _____	/ each
	1.29	Grooved ball-bearing ASPFL 208	01.03.2011 – 31.12.2015	159403	Unit(s) _____	/ each
	1.30	Chain sprocket	01.03.2011 – 31.12.2015	4990808	Unit(s) _____	/ each
	1.31	Guide roller Ø 70	01.03.2011 – 31.12.2015	4981037	Unit(s) _____	/ each
	1.32	Distance sleeve 10 mm	01.03.2011 – 31.12.2015	4991703	Unit(s) _____	/ each
	1.33	Adjusting ring	01.03.2011 – 31.12.2015	159163	Unit(s) _____	/ each
	1.34	Complete spiral support Right, LDH ≤ 5000 Left, LDH ≤ 5000 Right, LDH > 5000 Left, LDH > 5000	01.03.2011 – 31.12.2015 01.03.2011 – 31.12.2015 01.03.2011 – 31.12.2015 01.03.2011 – 31.12.2015	4990832 4990833 4990875 4990876	Unit(s) _____ _____ _____ _____	/ each / each / each / each

\* State purchase order number  
Surcharge for high-quality wet coating panel (see page 173)

# 1. High-Speed Door HS 7030 PU

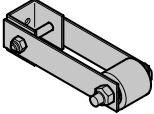
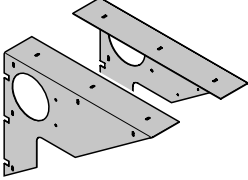
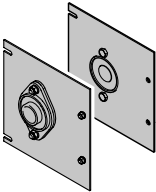
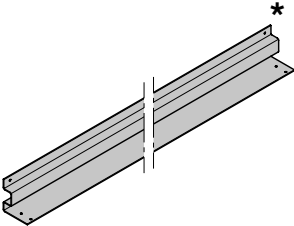
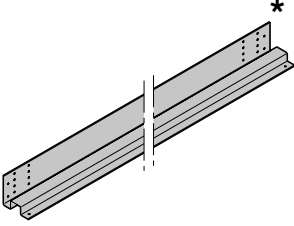
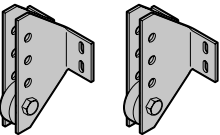
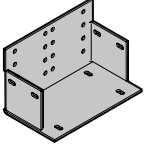
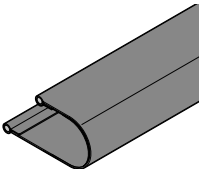
Article	Item Description	Production period	Art. no.	Quantity	€
	<b>1.35 Complete return pulley</b>	01.03.2011 – 31.12.2015	4991214	Unit(s) _____	/ each
	<b>1.36 Support sheet</b> <b>Right</b> , operator left <b>Left</b> , operator right	01.03.2011 – 31.12.2015 01.03.2011 – 31.12.2015	4990834 4990835	Unit(s) _____ _____	/ each / each
	<b>1.37 Complete inspection cover with bearing</b> <b>Right</b> , operator left <b>Left</b> , operator right	01.03.2011 – 31.12.2015 01.03.2011 – 31.12.2015	4990842 4990843	Unit(s) _____ _____	/ each / each
	<b>1.38 U-profile</b>	01.03.2011 – 31.12.2015	4990839	Unit(s) _____	/ m
	<b>1.39 Rear U-profile</b> 3-sided cladding only	01.03.2011 – 31.12.2015	4991399	Unit(s) _____	/ m
	<b>1.40 Complete pressure roller</b> (2 units)	01.03.2011 – 31.12.2015	4991839	Unit(s) _____	/ each
	<b>1.41 Support bracket</b> For pressure roller	01.03.2011 – 31.12.2015	4991849	Unit(s) _____	/ each
	<b>1.42 Curtain loop complete</b> 80, without ThermoFrame 100, with ThermoFrame	01.03.2011 – 31.12.2015 01.03.2011 – 31.12.2015	4991415 4991342	Unit(s) _____ _____	/ m / m

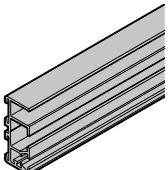
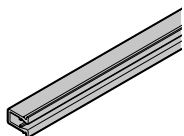
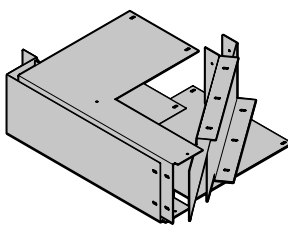
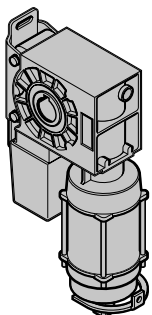
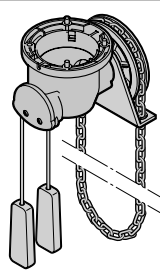
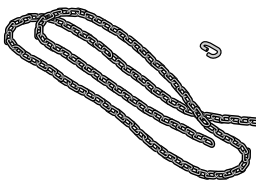
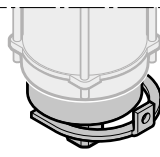

\* State purchase order number  
Surcharge for high-quality wet coating panel (see page 173)

# 1. High-Speed Door HS 7030 PU

Article	Item	Description	Production period	Art. no.	Quantity	€
	*	<b>1.43 Sealing frame channel</b>			Unit(s)	
		4000 mm	01.03.2011 – 31.12.2015	4991263	_____	/ each
		5000 mm	01.03.2011 – 31.12.2015	4991770	_____	/ each
		6000 mm	01.03.2011 – 31.12.2015	4991426	_____	/ each
	*	<b>1.44 Sealing frame clips</b>			Unit(s)	
		4000 mm	01.03.2011 – 31.12.2015	4991264	_____	/ each
		5000 mm	01.03.2011 – 31.12.2015	4991771	_____	/ each
		6000 mm	01.03.2011 – 31.12.2015	4991427	_____	/ each
		<b>1.45 Cladding, complete</b>	01.03.2011 – 31.12.2015	4991158	Unit(s) _____	/ each
	*	<b>1.46 Operator</b>	01.03.2011 – 31.12.2015		Unit(s) _____	/ each
		<b>1.47 Emergency hand chain gearbox</b>	01.03.2011 – 31.12.2015	158171	Unit(s) _____	/ each
		<b>1.48 hand chain 10 m</b> With chain link	01.03.2011 – 31.12.2015	4982733	Unit(s) _____	/ each
		<b>1.49 Brake 11 Nm</b>			Unit(s)	
		103 V DC	01.03.2011 – 31.05.2015	157686	_____	/ each
		24 V LH U	01.06.2015 – 31.12.2015	4982120	_____	/ each

\* State purchase order number  
 Surcharge for high-quality wet coating panel (see page 173)

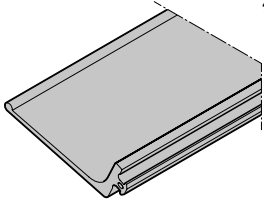
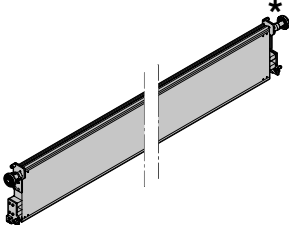
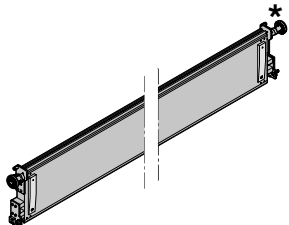
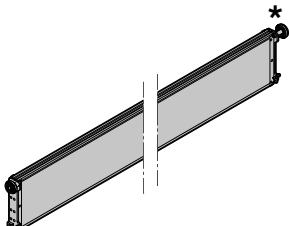
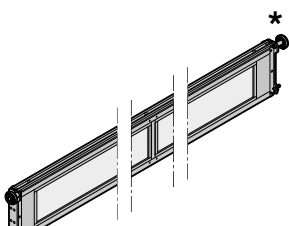
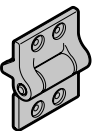
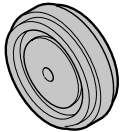
# 1. High-Speed Door HS 7030 PU

Article	Item	Description	Production period	Art. no.	Quantity	€
	*	<b>1.50 Panel lintel seal</b>	01.07.2012 – 31.12.2015	4991790	Unit(s) _____	/ m
	*	<b>1.51 Complete top panel</b> Section height: 225 mm Standard version: RAL 9006	01.03.2011 – 30.06.2014	4991506	Unit(s) _____ _____	/ m / each
	*	<b>1.52 Top panel, complete with alignment mechanism</b> Section height: 225 mm Standard version: RAL 9006	01.07.2014 – 31.12.2015	4991848	Unit(s) _____ _____	/ m / each
	*	<b>1.53 Inclination panel</b> Section height: 225 mm Standard version: RAL 9006	01.03.2011 – 31.12.2015	4990820	Unit(s) _____ _____	/ m / each
	*	<b>1.54 Complete window profile</b> Double glazing Triple glazing Section height: 225 mm	01.03.2011 – 31.12.2015 01.03.2011 – 31.12.2015	4990819 4990819	Unit(s) _____ _____ _____	/ m / each / m / each
		<b>1.55 Complete centre hinge</b> With screws black Silver	01.03.2011 – 31.12.2015 01.03.2011 – 31.12.2015	4990838 4990797	Unit(s) _____ _____	/ each / each
		<b>1.56 Roller with band</b> For panels	01.03.2011 – 31.12.2015	4990818	Unit(s) _____	/ each
		<b>1.57 Complete hinge connector</b>	01.03.2011 – 31.12.2015	4981937	Unit(s) _____	/ each

\* State purchase order number  
Surcharge for high-quality wet coating panel (see page 173)

# 1. High-Speed Door HS 7030 PU

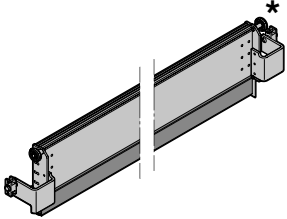
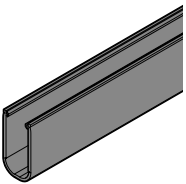
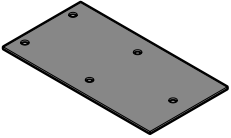
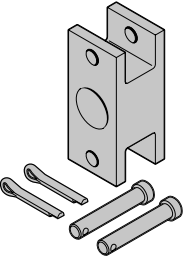
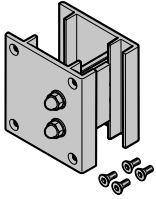
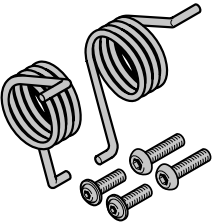
Article	Item Description	Production period	Art. no.	Quantity	€
	<b>1.58 Bottom part Complete</b>	01.03.2011 – 31.12.2015	4990821	Unit(s) _____ _____	/ m / each
	<b>1.59 Rubber profile Velcro strap</b> (additionally required: Velcro strap 1 m and 2 x light grille cover)	01.03.2011 – 31.12.2015 01.03.2011 –	306843 159601	Unit(s) _____ _____	/ m / m
	<b>1.60 Light grille cover</b>	01.03.2011 –	4991720	Unit(s) _____	/ each
	<b>1.61 Complete chain connection</b>	01.03.2011 – 31.12.2015	4990824	Unit(s) _____	/ each
	<b>1.62 Fixing clip</b> To hold the curtain in place when exchanging panels	01.03.2011 – 31.12.2015	4990854	Unit(s) _____	/ each
	<b>1.63 Replacement of leg springs</b>	01.06.2014 –	4981012	Unit(s) _____	/ each

\* State purchase order number  
Surcharge for high-quality wet coating panel (see page 173)

# HS 5015 PU N

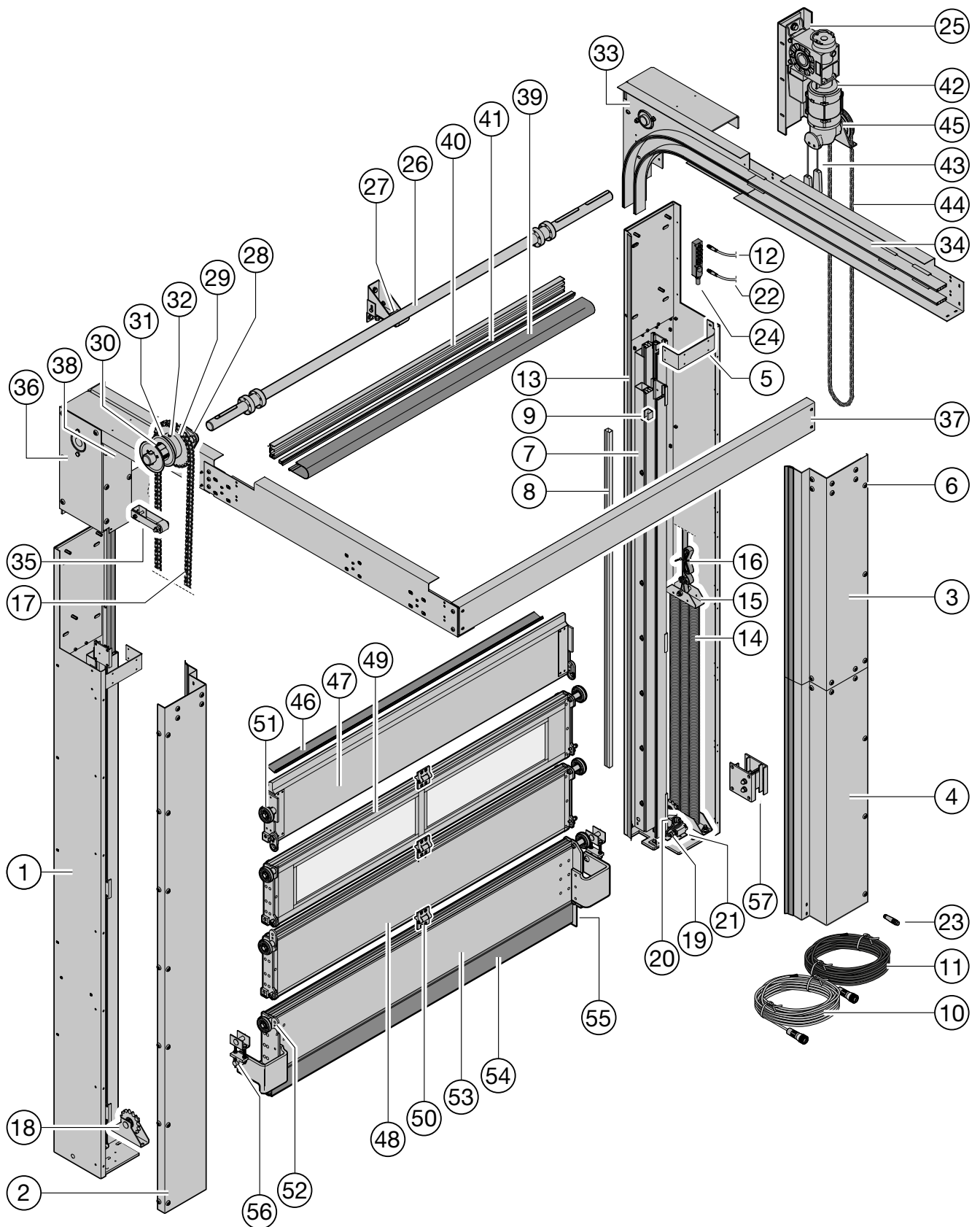

## 2. High-Speed Door HS 5015 PU N

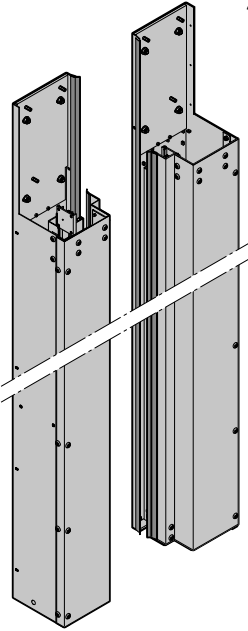
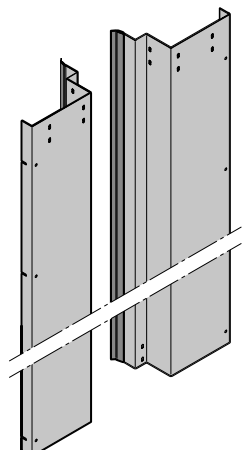
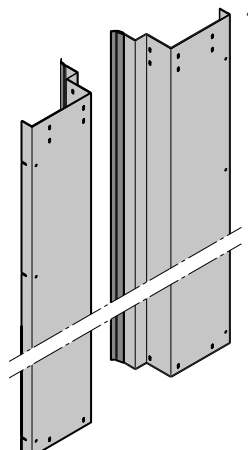
Article	Item	Description	Production period	Art. no.	Quantity	€
	*	<b>2.1 Side element</b>			Unit(s)	
		Right	01.07.2012 – 31.12.2015	4991345	_____	/ each
		Left	01.07.2012 – 31.12.2015	4991346	_____	/ each
	*	<b>2.2 Cover, 1-part</b>			Unit(s)	
		LDH ≤ 3250 mm Right	01.07.2012 – 31.12.2015	4991180	_____	/ m / each
		Left	01.07.2012 – 31.12.2015	4991183	_____	/ m / each
	*	<b>2.3 Top cover, 2-part</b>			Unit(s)	
		LDH > 3250 mm Right	01.07.2012 – 31.12.2015	4991182	_____	/ m / each
		Left	01.07.2012 – 31.12.2015	4991185	_____	/ m / each

\* State purchase order number

Surcharge for high-quality wet coating panel (see page 173)

EN Ceiling height

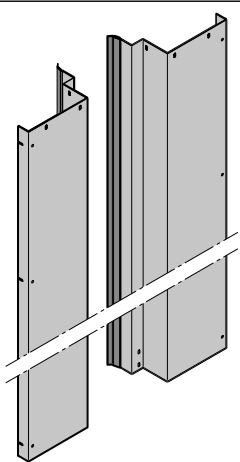
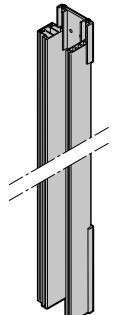
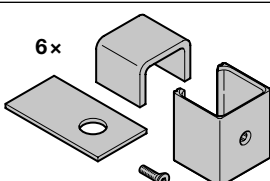

DA Distance to ceiling

## 2. High-Speed Door HS 5015 PU N

Article	Item	Description	Production period	Art. no.	Quantity	€
	*	<b>2.4 Bottom cover, 2-part</b> LDH > 3250 mm Right Left	01.07.2012 – 31.12.2015 01.07.2012 – 31.12.2015	4991181 4991184	Unit(s) _____ _____	/ m / each / m / each
		<b>2.5 Cover bar</b>	01.07.2012 – 31.12.2015	4990830	Unit(s) _____	/ each
		<b>2.6 Self-tapping screws M6 x 12</b> Screws for cover 50x		4992181	Unit(s) _____	/ each
	*	<b>2.7 Complete aluminium profile guide</b> Right Left	01.07.2012 – 31.12.2015 01.07.2012 – 31.12.2015	4980066 4980065	Unit(s) _____ _____	/ m / each / m / each
	*	For article numbers and lengths, see pages 176 – 178 / cable concept	01.07.2012 – 31.12.2015		Unit(s) _____	/ each
	6x	<b>2.8 Holder for</b>	01.07.2012 – 31.12.2015	4981440	Unit(s) _____	/ each

\* State purchase order number  
 Surcharge for high-quality wet coating panel (see page 173)  
 EN Ceiling height  
 DA Distance to ceiling

## 2. High-Speed Door HS 5015 PU N

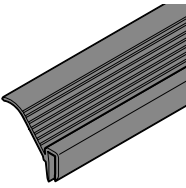
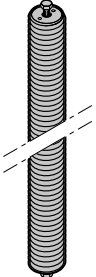
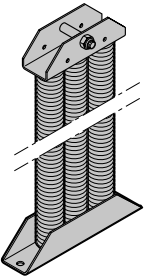
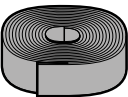
Article	Item	Description	Production period	Art. no.	Quantity	€
	<b>2.9</b>	<b>Grey cable, 15 m</b> Receiver always fitted on left, only FUEH	01.07.2012 – 31.05.2015	4990759	Unit(s) _____	/ each
	<b>2.10</b>	<b>Black cable, 15 m</b> Transmitter always fitted on right, only FUEH	01.07.2012 – 31.05.2015	4990760	Unit(s) _____	/ each
	*	<b>2.11 Snap cable, white</b> For article numbers and lengths, see pages 176 – 178 / cable concept	01.06.2015 – 31.12.2015		Unit(s) _____	/ each
	*	<b>2.12 Seal for guide</b> Additional 2 × per side element required  4000 mm 5000 mm 6000 mm	01.06.2015 – 31.12.2015 01.06.2015 – 31.12.2015 01.06.2015 – 31.12.2015	4991585 4991586 4991490	Unit(s) _____ _____ _____	/ each / each / each
	*	<b>2.13 Single spring</b>	01.07.2012 – 31.12.2015		Unit(s) _____	/ each
	*	<b>2.14 Complete spring assembly</b>  Right Left	01.07.2012 – 31.12.2015 01.07.2012 – 31.12.2015		Unit(s) _____ _____	/ each / each
	*	<b>2.15 Belt</b>  3950 mm 5200 mm 7200 mm LDH + 100 mm per side serves as a calculation aid	01.01.2016 – 01.01.2016 – 01.01.2016 –	4990496 4990496 4990496	Unit(s) _____ _____ _____	/ each / each / each



\* State purchase order number

Surcharge for high-quality wet coating panel (see page 173)

EN Ceiling height

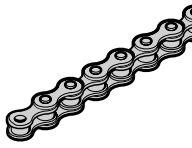
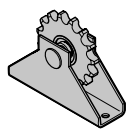
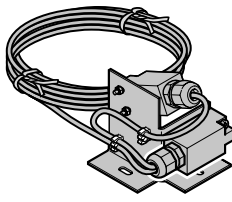
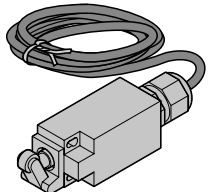
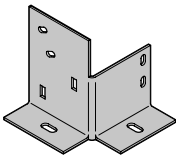

DA Distance to ceiling

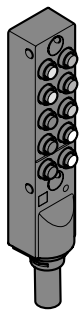
## 2. High-Speed Door HS 5015 PU N

Article	Item	Description	Production period	Art. no.	Quantity	€
	<b>2.16</b>	<b>Roller chain reinforced</b>	01.07.2012 – 31.12.2015	159568	m	/ m
	<b>2.17</b>	<b>Complete chain tensioner wheel</b>			Unit(s)	
		Right	01.07.2012 – 31.12.2015	4990809	_____	/ each
		Left	01.07.2012 – 31.12.2015	4990810	_____	/ each
	<b>2.18</b>	<b>Button with wiring</b>			Unit(s)	
		For spring and chain monitoring				
		Right	01.07.2012 –	4980327	_____	/ each
		Left	01.07.2012 –	4980337	_____	/ each
	<b>2.19</b>	<b>Chain test button</b>			Unit(s)	
		Right	01.07.2012 –	4992012	_____	/ each
		Left	01.07.2012 –	4992011	_____	/ each
	<b>2.20</b>	<b>Button support</b>			Unit(s)	
		Right	01.07.2012 – 31.12.2015	4991130	_____	/ each
		Left	01.07.2012 – 31.12.2015	4991131	_____	/ each
	<b>* 2.21</b>	<b>Snap cable</b>			Unit(s)	
		blue, spring / counter weight	01.06.2015 – 31.12.2015		_____	/ each
		yellow, belt monitoring	01.06.2015 – 31.12.2015		_____	/ each
		For article numbers and lengths, see pages 176 – 178 / cable concept				
	<b>2.22</b>	<b>Bridge plug snap 8</b>	01.06.2015 – 31.12.2015	4980188	Unit(s)	/ each
	<b>* 2.23</b>	<b>Distributor 10 x M8 snap</b>	01.06.2015 – 31.12.2015		Unit(s)	/ each
		For article numbers and lengths, see pages 176 – 178 / cable concept				

\* State purchase order number  
 Surcharge for high-quality wet coating panel (see page 173)  
 EN Ceiling height  
 DA Distance to ceiling

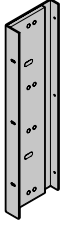
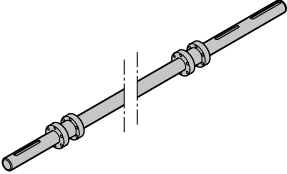
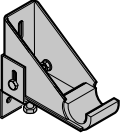
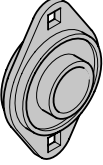
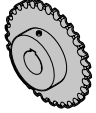
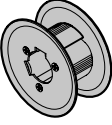
## 2. High-Speed Door HS 5015 PU N

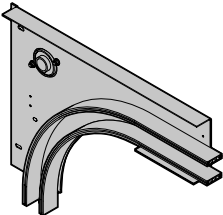
Article	Item	Description	Production period	Art. no.	Quantity	€
	2.24	Complete operator support bracket	01.07.2012 – 31.12.2015	4990800	Unit(s) _____	/ each
	2.25	Complete shaft	01.07.2012 – 31.12.2015	4991591	Unit(s) _____	/ m / each
	2.26	Shaft support	01.07.2012 – 31.12.2015	4990877	Unit(s) _____	/ each
	2.27	Grooved ball-bearing ASPFL 208	01.07.2012 – 31.12.2015	159403	Unit(s) _____	/ each
	2.28	Chain sprocket	01.07.2012 – 31.12.2015	4990808	Unit(s) _____	/ each
	2.29	Guide roller Ø 70	01.07.2012 – 31.12.2015	4981037	Unit(s) _____	/ each
	2.30	Distance sleeve 10 mm	01.07.2012 – 31.12.2015	4991703	Unit(s) _____	/ each
	2.31	Adjusting ring	01.07.2012 – 31.12.2015	159163	Unit(s) _____	/ each
	2.32	Complete support curve	01.07.2012 – 31.12.2015	4991173	Unit(s) _____	/ each
		Right	01.07.2012 – 31.12.2015	4991173	_____	/ each
		Left	01.07.2012 – 31.12.2015	4991174	_____	/ each

- \* State purchase order number  
 Surcharge for high-quality wet coating panel (see page 173)  
 EN Ceiling height  
 DA Distance to ceiling

## 2. High-Speed Door HS 5015 PU N

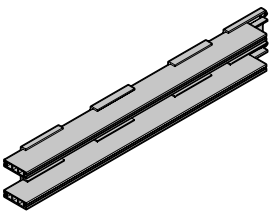
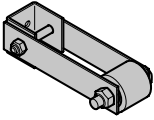
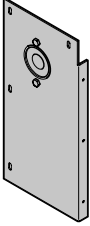
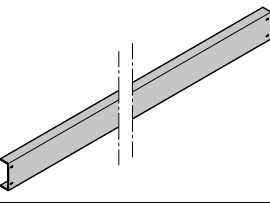
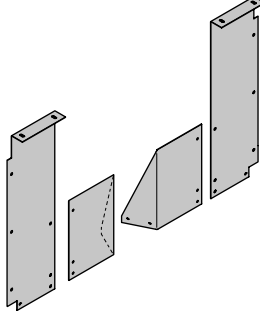
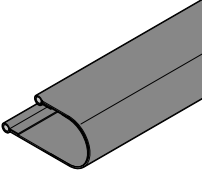
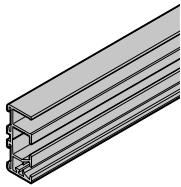
Article	Item	Description	Production period	Art. no.	Quantity	€
	*	<b>2.33 Complete horizontal guide</b>			Unit(s)	
		Right	01.07.2012 – 31.12.2015	4991186	_____	/ m
		Left	01.07.2012 – 31.12.2015	4991187	_____	/ m
		<b>2.34 Complete return pulley</b>	01.07.2012 – 31.12.2015	4991214	Unit(s) _____	/ each
		<b>2.35 Complete cladding, bearing side</b>			Unit(s)	
		Right	01.07.2012 – 31.12.2015	4991189	_____	/ each
		Left	01.07.2012 – 31.12.2015	4991188	_____	/ each
	*	<b>2.36 Transverse cross strut</b>	01.07.2012 – 31.12.2015	4991215	Unit(s) _____	/ m
		<b>2.37 Cladding, complete</b>	01.07.2012 – 31.12.2015	4991492	Unit(s) _____	/ each
	*	<b>2.38 Curtain loop complete</b>			Unit(s)	
		80, without ThermoFrame	01.07.2012 – 31.12.2015	4991415	_____	/ m
		100, with ThermoFrame	01.07.2012 – 31.12.2015	4991342	_____	/ m
	*	<b>2.39 Sealing frame channel</b>			Unit(s)	
		4000 mm	01.07.2012 – 31.12.2015	4991263	_____	/ each
		5000 mm	01.07.2012 – 31.12.2015	4991770	_____	/ each
		6000 mm	01.07.2012 – 31.12.2015	4991426	_____	/ each

\* State purchase order number

Surcharge for high-quality wet coating panel (see page 173)

EN Ceiling height

DA Distance to ceiling

## 2. High-Speed Door HS 5015 PU N

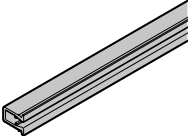
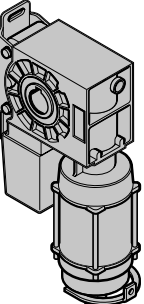
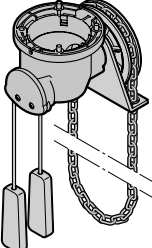
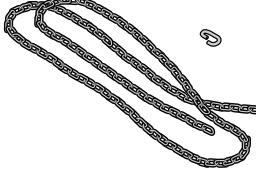
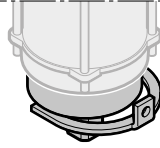
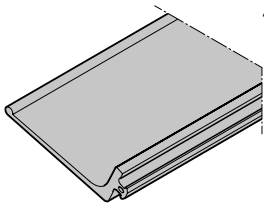
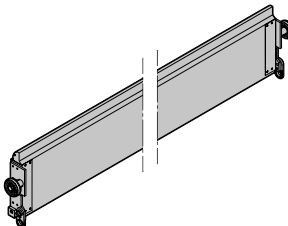
Article	Item	Description	Production period	Art. no.	Quantity	€
	*	<b>2.40 Sealing frame clips</b>			Unit(s)	
		4000 mm	01.07.2012 – 31.12.2015	4991264	_____	/ each
		5000 mm	01.07.2012 – 31.12.2015	4991771	_____	/ each
		6000 mm	01.07.2012 – 31.12.2015	4991427	_____	/ each
	*	<b>2.41 Operator</b>	01.07.2012 – 31.12.2015		Unit(s)	/ each
		<b>2.42 Emergency hand chain gearbox</b>	01.07.2012 – 31.12.2015	158171	Unit(s)	/ each
		<b>2.43 hand chain 10 m</b> With chain link	01.07.2012 – 31.12.2015	4982733	Unit(s)	/ each
		<b>2.44 Brake 11 Nm</b>			Unit(s)	
		103 V DC	01.07.2012 – 31.05.2015	157686	_____	/ each
		24 V LH U	01.07.2012 – 31.12.2015	4982120	_____	/ each
	*	<b>2.45 Panel lintel seal</b>	01.07.2012 – 31.12.2015	4991790	Unit(s)	/ m
	*	<b>2.46 Complete top panel</b>	01.07.2012 – 31.12.2015	4991507	Unit(s)	/ m
		Section height: 225 mm			_____	/ each
		Standard version: RAL 9006			_____	

\* State purchase order number

Surcharge for high-quality wet coating panel (see page 173)

EN Ceiling height

DA Distance to ceiling

## 2. High-Speed Door HS 5015 PU N

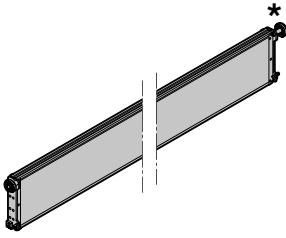
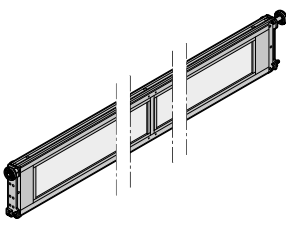
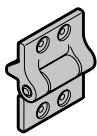
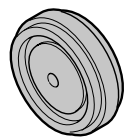
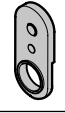
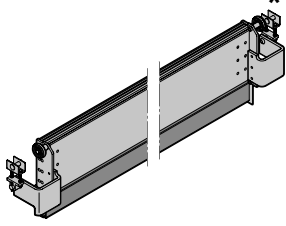
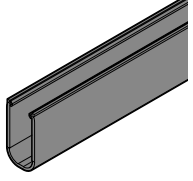
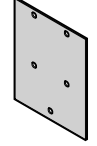
Article	Item Description	Production period	Art. no.	Quantity	€
	<b>2.47 Inclination panel</b> Section height: 225 mm Standard version: RAL 9006	01.07.2012 – 31.12.2015	4990820	Unit(s) _____	/ m / each
	<b>2.48 Complete window profile</b> Double glazing Triple glazing Section height: 225 mm Standard version: RAL 9006	01.07.2012 – 31.12.2015 01.07.2012 – 31.12.2015	4990819 4990819	Unit(s) _____ _____	/ m / each / m / each
	<b>2.49 Complete centre hinge</b> With screws black Silver	01.07.2012 – 31.12.2015 01.07.2012 – 31.12.2015	4990838 4990797	Unit(s) _____ _____	/ each / each
	<b>2.50 Roller with band</b> For panels	01.07.2012 – 31.12.2015	4990818	Unit(s) _____	/ each
	<b>2.51 Complete hinge connector</b>	01.07.2012 – 31.12.2015	4981937	Unit(s) _____	/ each
	<b>2.52 Bottom part Complete</b>	01.07.2012 – 31.12.2015	4991169	Unit(s) _____	/ m / each
	<b>2.53 Rubber profile Velcro strap</b> (additionally required Velcro strap 1 m)	01.07.2012 – 31.12.2015 01.03.2011 –	306843 159601	Unit(s) _____ _____	/ m / m
	<b>2.54 UPVC canopy</b>	01.07.2012 – 31.12.2015	4991720	Unit(s) _____	/ each

\* State purchase order number

Surcharge for high-quality wet coating panel (see page 173)

EN Ceiling height

DA Distance to ceiling

## 2. High-Speed Door HS 5015 PU N

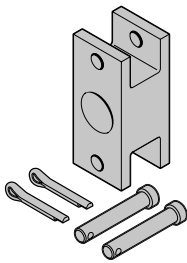
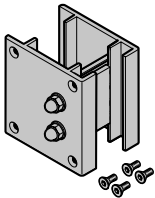
Article	Item	Description	Production period	Art. no.	Quantity	€
	<b>2.55</b>	<b>Complete chain connection</b>	01.07.2012 – 31.12.2015	4991430	Unit(s) _____	/ each
	<b>2.56</b>	<b>Fixing clip</b> To hold the curtain in place when exchanging panels	01.07.2012 – 31.12.2015	4990854	Unit(s) _____	/ each

\* State purchase order number

Surcharge for high-quality wet coating panel (see page 173)

EN Ceiling height

DA Distance to ceiling

# HS 5015 PU H

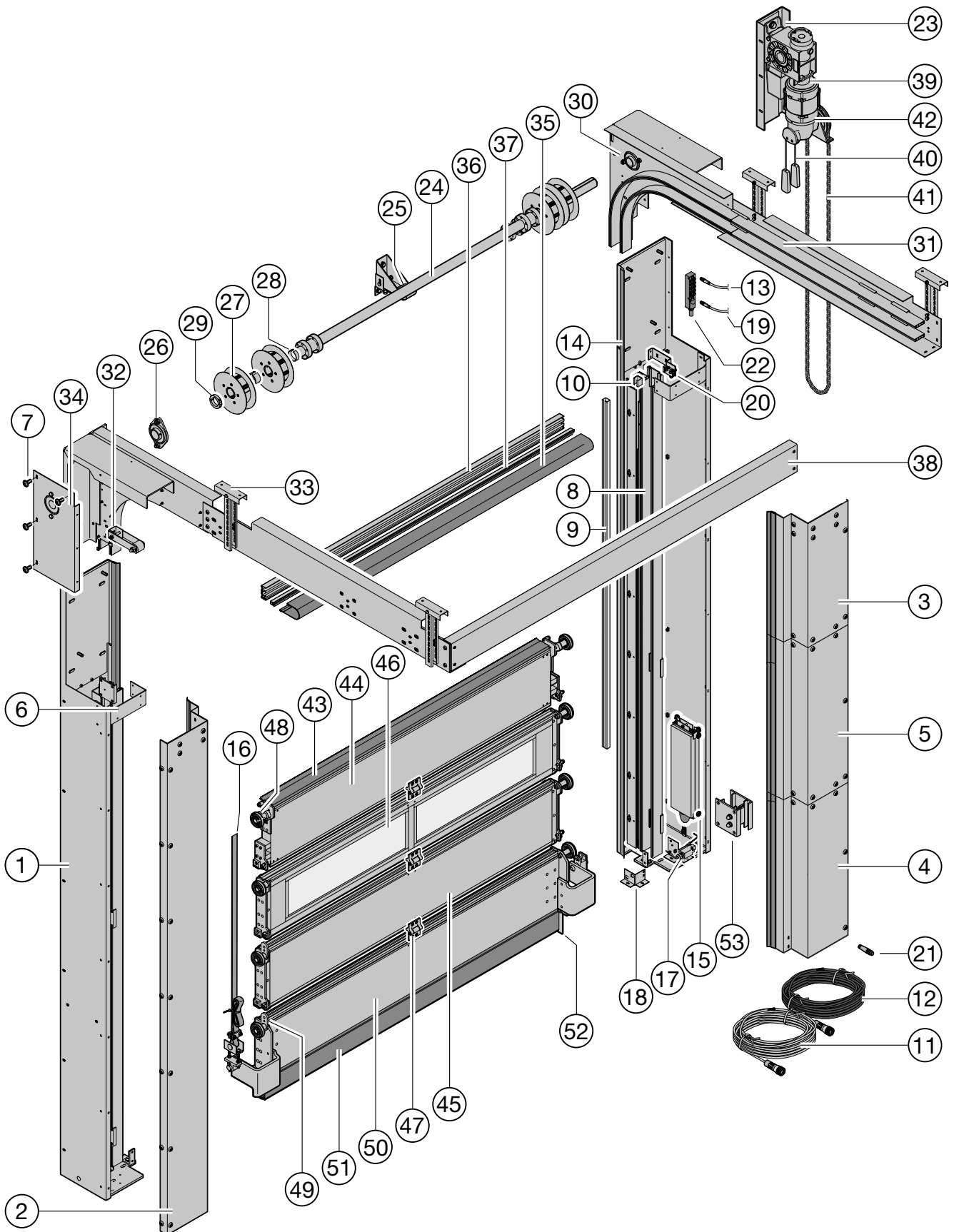

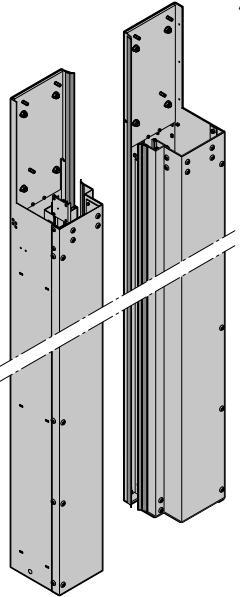
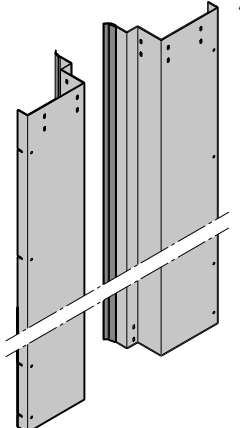
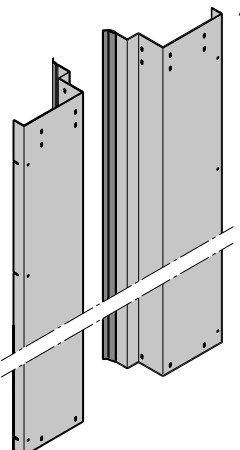

### 3. High-Speed Door HS 5015 PU H

Article	Item	Description	Production period	Art. no.	Quantity	€
	*	<b>3.1 Side element</b>			Unit(s)	
		Right	01.08.2013 – 31.12.2015	4991589	_____	/ each
		Left	01.08.2013 – 31.12.2015	4991590	_____	/ each
	*	<b>3.2 Cover, 1-part</b>			Unit(s)	
		DH ≤ 4000 mm Right	01.08.2013 – 31.12.2015	4991439	_____	/ m / each
	Left	01.08.2013 – 31.12.2015	4991443	_____	/ m / each	
	*	<b>3.3 Top cover, 2-part</b>			Unit(s)	
		DH > 4000 mm Right	01.08.2013 – 31.12.2015	4991440	_____	/ m / each
	Left	01.08.2013 – 31.12.2015	4991444	_____	/ m / each	



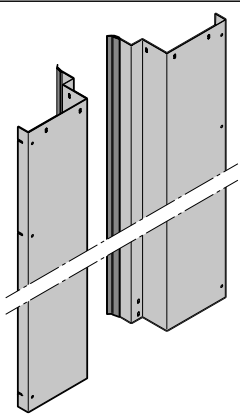
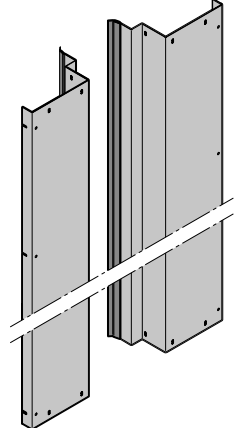
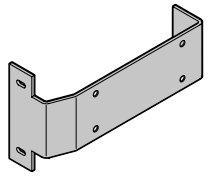

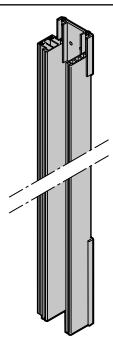
\* State purchase order number  
 Surcharge for high-quality wet coating panel (see page 173)  
 DH Ceiling height

### 3. High-Speed Door HS 5015 PU H

Article	Item	Description	Production period	Art. no.	Quantity	€
	*	<b>3.4 Bottom cover, 2-part</b>			Unit(s)	
		DH > 4000 mm Right	01.08.2013 – 31.12.2015	4991441	_____	/ m
		Left	01.08.2013 – 31.12.2015	4991445	_____	/ each / m / each
	*	<b>3.5 Centre cover, 3-part</b>			Unit(s)	
		DH > 6500 mm Right	01.08.2013 – 31.12.2015	4991442	_____	/ m
		Left	01.08.2013 – 31.12.2015	4991436	_____	/ each / m / each
		<b>3.6 Cover bar</b>	01.08.2013 – 31.12.2015	4990830	Unit(s) _____	/ each
 50x		<b>3.7 Self-tapping screws M6 x 12</b> Screws for cover		4992181	Unit(s) _____	/ each
	*	<b>3.8 Complete aluminium profile guide</b>			Unit(s)	
		Right	01.08.2013 – 31.12.2015	4991475	_____	/ m
		Left	01.08.2013 – 31.12.2015	4991476	_____	/ each / m / each

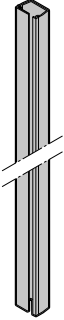
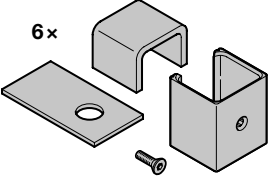



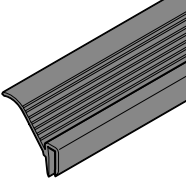
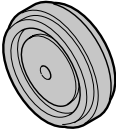
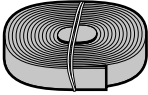

\* State purchase order number  
 Surcharge for high-quality wet coating panel (see page 173)  
 DH Ceiling height

### 3. High-Speed Door HS 5015 PU H

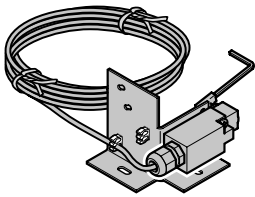
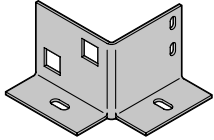
Article	Item	Description	Production period	Art. no.	Quantity	€
	*	<b>3.9 Light grille</b> For article numbers and lengths see pages 176 – 178 light grille / cable concept	01.08.2013 – 31.12.2015		Unit(s) _____	/ each
	6x	<b>3.10 Holder For light grille</b>	01.08.2013 – 31.12.2015	4981440	Unit(s) _____	/ each
		<b>3.11 Cable, light grille, grey, 15 m</b> Receiver always fitted on left, only FUEH	01.08.2013 – 31.05.2015	4990759	Unit(s) _____	/ each
		<b>3.12 Cable, light grille, black, 15 m</b> Transmitter always fitted on right, only FUEH	01.08.2013 – 31.05.2015	4990760	Unit(s) _____	/ each
	*	<b>3.13 Snap cable, white, light grille</b> For article numbers and lengths see pages 176 – 178 light grille / cable concept	01.06.2015 – 31.12.2015		Unit(s) _____	/ each
	*	<b>3.14 Seal for guide</b> Additional 2 x per side element required  4000 mm 5000 mm 6000 mm	01.03.2011 – 31.05.2015 01.03.2011 – 31.05.2015 01.03.2011 – 31.05.2015	4991585 4991586 4991490	Unit(s) _____ _____ _____	/ each / each / each
		<b>3.15 Roller</b> For the counter weight	01.08.2013 – 31.12.2015	159413	Unit(s) _____	/ each
		<b>3.16 Flat belt 30 mm</b> For curtain and weight	01.08.2013 – 31.12.2015	4991432	Unit(s) _____	/ m

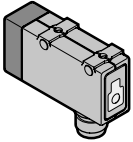
\* State purchase order number  
 Surcharge for high-quality wet coating panel (see page 173)  
 DH Ceiling height

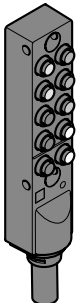
### 3. High-Speed Door HS 5015 PU H





Article	Item	Description	Production period	Art. no.	Quantity	€
	<b>3.17</b>	<b>Button counter weight wired, M8 snap</b>			Unit(s)	
	Right		01.08.2013 –	4980425	_____	/each
	Left		01.08.2013 –	4980424	_____	/each
	<b>3.18</b>	<b>Button support</b>			Unit(s)	
	Right		01.03.2011 – 31.12.2015	4981585	_____	/each
	Left		01.03.2011 – 31.12.2015	4981586	_____	/each
	*	<b>3.19</b> <b>Snap cable</b>			Unit(s)	
		blue, spring / counter weight yellow, belt monitoring For article numbers and lengths see pages 176 – 178 light grille / cable concept	01.06.2015 – 31.12.2015 01.06.2015 – 31.12.2015		_____ _____	/each /each
	<b>3.20</b>	<b>Light button reflection</b>			Unit(s)	
		Discontinued articles The support bracket of the existing switch is not compatible with the new switch. You need the new support bracket (7992043, €8.40) to replace the switch. For curtain belt monitoring	01.08.2013 – 31.12.2015 01.08.2013 – 31.12.2015	4991409 4982897	_____ _____	/each /each
	<b>3.21</b>	<b>Bridge plug snap8</b>	01.06.2015 – 31.12.2015	4980188	Unit(s) _____	/each
	*	<b>3.22</b> <b>Distributor 10 x, M8 snap</b>	01.06.2015 – 31.12.2015		Unit(s) _____	/each
		For article numbers and lengths see pages 176 – 178 light grille / cable concept				
	<b>3.23</b>	<b>Complete operator support bracket</b>	01.08.2013 – 31.12.2015	4990800	Unit(s) _____	/each

\* State purchase order number

Surcharge for high-quality wet coating panel (see page 173)

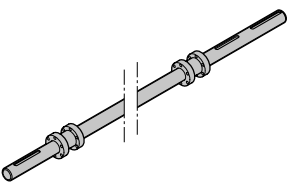
DH Ceiling height

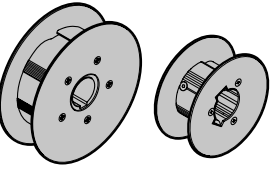
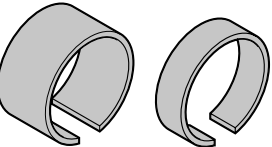
### 3. High-Speed Door HS 5015 PU H

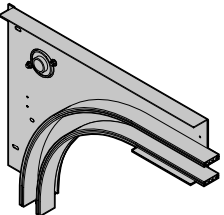
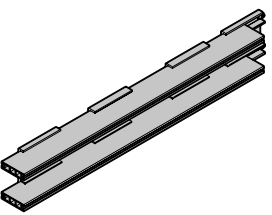
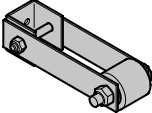
Article	Item	Description	Production period	Art. no.	Quantity	€
	*	<b>3.24 Complete shaft</b>	01.08.2013 – 31.12.2015	4991592	Unit(s) _____	/ m / each
		<b>3.25 Shaft support complete</b>	01.08.2013 – 31.12.2015	4990877	Unit(s) _____	/ each
		<b>3.26 Grooved ball-bearing ASPFL 208</b>	01.08.2013 – 31.12.2015	159403	Unit(s) _____	/ each
		<b>3.27 Pulley</b> Ø 145 Ø 70	01.08.2013 – 31.12.2015 01.08.2013 – 31.12.2015	4991433 4991632	Unit(s) _____ _____	/ each / each
		<b>3.28 distance sleeve</b> 27 mm 14 mm	01.08.2013 – 31.12.2015 01.08.2013 – 31.12.2015	4991434 4991438	Unit(s) _____ _____	/ each / each
		<b>3.29 Adjusting ring</b>	01.08.2013 – 31.12.2015	159163	Unit(s) _____	/ each
	*	<b>3.30 Complete support curve</b> Right Left	01.08.2013 – 31.12.2015 01.08.2013 – 31.12.2015	4991173 4991174	Unit(s) _____ _____	/ each / each
	*	<b>3.31 Complete horizontal guide</b> Right Left	01.08.2013 – 31.12.2015 01.08.2013 – 31.12.2015	4991480 4991481	Unit(s) _____ _____	/ m / m
		<b>3.32 Complete return pulley</b>	01.08.2013 – 31.12.2015	4991214	Unit(s) _____	/ each

\* State purchase order number  
 Surcharge for high-quality wet coating panel (see page 173)  
 DH Ceiling height

### 3. High-Speed Door HS 5015 PU H

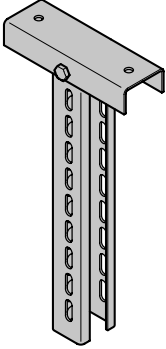
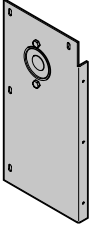
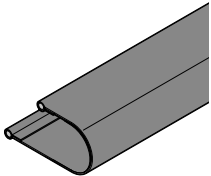
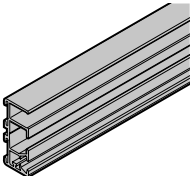
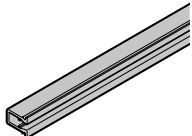
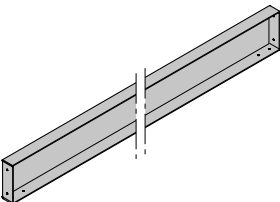
Article	Item Description	Production period	Art. no.	Quantity	€
	<b>3.33 Track suspension</b> Additionally required fixing material	01.08.2013 – 31.12.2015 01.08.2013 – 31.12.2015	4991282 4981415	Unit(s) _____ _____	/ each / each
	<b>3.34 Complete cladding, bearing side</b>  Right Left	01.08.2013 – 31.12.2015 01.08.2013 – 31.12.2015	4991189 4991188	Unit(s) _____ _____	/ each / each
	* <b>3.35 Curtain loop complete</b>  80, without ThermoFrame 100, with ThermoFrame	01.08.2013 – 31.12.2015 01.08.2013 – 31.12.2015	4991415 4991342	Unit(s) _____ _____	/ m / m
	* <b>3.36 Sealing frame channel</b>  4000 mm 5000 mm 6000 mm	01.08.2013 – 31.12.2015 01.08.2013 – 31.12.2015 01.08.2013 – 31.12.2015	4991263 4991770 4991426	Unit(s) _____ _____ _____	/ each / each / each
	* <b>3.37 Sealing frame clips</b>  4000 mm 5000 mm 6000 mm	01.08.2013 – 31.12.2015 01.08.2013 – 31.12.2015 01.08.2013 – 31.12.2015	4991264 4991771 4991427	Unit(s) _____ _____ _____	/ each / each / each
	* <b>3.38 Transverse cross strut</b>	01.08.2013 – 31.12.2015	4991477	Unit(s) _____	/ m / each

\* State purchase order number  
 Surcharge for high-quality wet coating panel (see page 173)  
 DH Ceiling height

### 3. High-Speed Door HS 5015 PU H

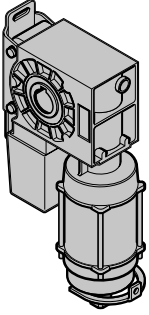
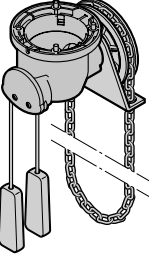
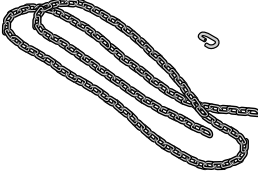
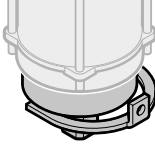
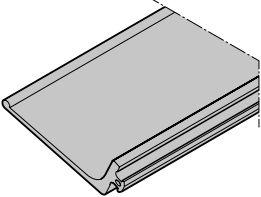
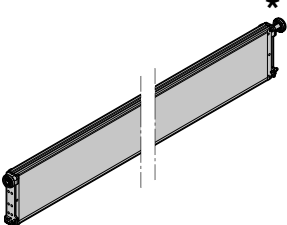
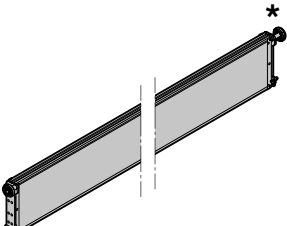
Article	Item	Description	Production period	Art. no.	Quantity	€
	*	<b>3.39 Operator</b>	01.08.2013 – 31.12.2015		Unit(s) _____	/ each
		<b>3.40 Emergency hand chain gearbox</b>	01.08.2013 – 31.12.2015	158171	Unit(s) _____	/ each
		<b>3.41 hand chain 10 m</b> With chain link	01.08.2013 – 31.12.2015	4982733	Unit(s) _____	/ each
		<b>3.42 Brake 11 Nm</b> 103 V DC 24 V LH U	01.08.2013 – 31.05.2015 01.06.2015 –	157686 4982120	Unit(s) _____ _____	/ each / each
		<b>3.43 Panel lintel seal</b>	01.08.2013 – 31.12.2015	4991790	Unit(s) _____	/ m
	*	<b>3.44 Complete top panel</b> Section height: 225 mm Standard version: RAL 9006	01.08.2013 – 31.12.2015	4991661	Unit(s) _____	/ m / each
	*	<b>3.45 Inclination panel</b> Section height: 225 mm Standard version: RAL 9006	01.08.2013 – 31.12.2015	4990820	Unit(s) _____	/ m / each

\* State purchase order number  
 Surcharge for high-quality wet coating panel (see page 173)  
 DH Ceiling height

### 3. High-Speed Door HS 5015 PU H

Article	Item	Description	Production period	Art. no.	Quantity	€
	*	<b>3.46 Complete window profile</b>			Unit(s)	
		Double glazing	01.08.2013 – 31.12.2015	4990819	_____	/ m
		Triple glazing	01.08.2013 – 31.12.2015	4990819	_____	/ each / m / each
		Section height: 225 mm Standard version: RAL 9006				
		<b>3.47 Complete centre hinge</b> With screws			Unit(s)	
		black	01.08.2013 – 31.12.2015	4990838	_____	/ each
		Silver	01.08.2013 – 31.12.2015	4990797	_____	/ each
		<b>3.48 Roller with band</b> For panels	01.08.2013 – 31.12.2015	4990818	Unit(s) _____	/ each
		<b>3.49 Complete hinge connector</b>	01.08.2013 – 31.12.2015	4981937	Unit(s) _____	/ each
	*	<b>3.50 Bottom part Complete</b>			Unit(s)	
			01.08.2013 – 31.12.2015	4991478	_____	/ m / each
	*	<b>3.51 Rubber profile Velcro strap</b> (additionally required: Velcro strap 1 m)			Unit(s)	
			01.08.2013 – 31.12.2015 01.03.2011 –	306843 159601	_____ _____	/ m / m
		<b>3.52 UPVC canopy</b>	01.08.2013 – 31.12.2015	4991720	Unit(s) _____	/ each
		<b>3.53 Fixing clip</b> To hold the curtain in place when exchanging panels	01.08.2013 – 31.12.2015	4990854	Unit(s) _____	/ each

\* State purchase order number  
 Surcharge for high-quality wet coating panel (see page 173)  
 DH Ceiling height

# HS 6015 PU V

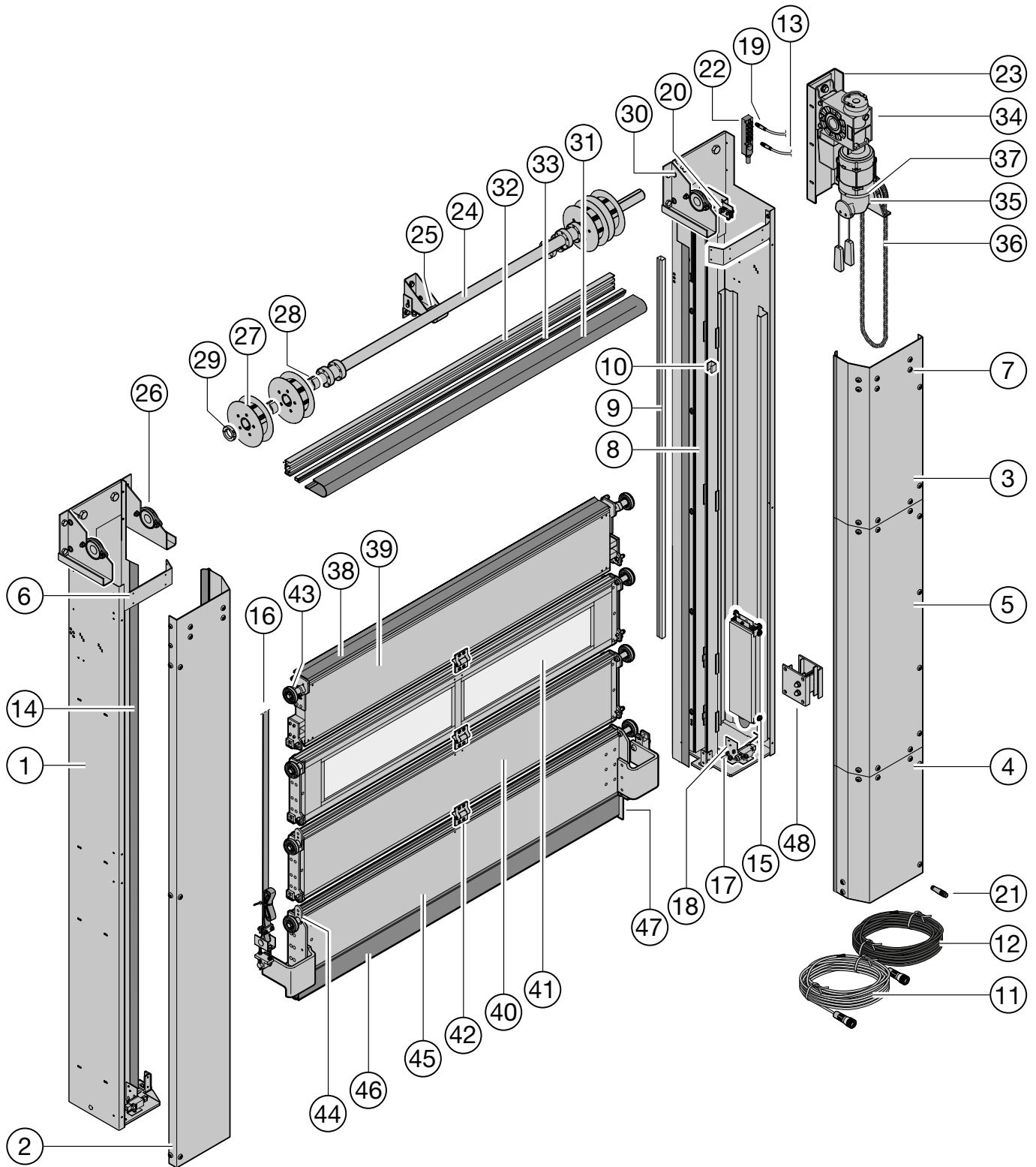

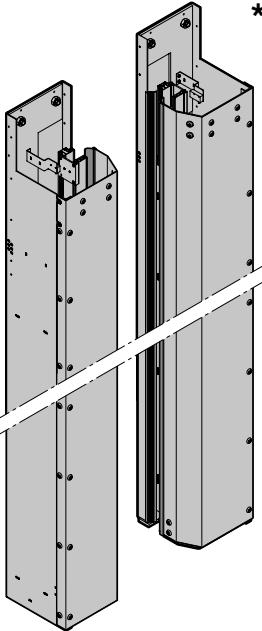
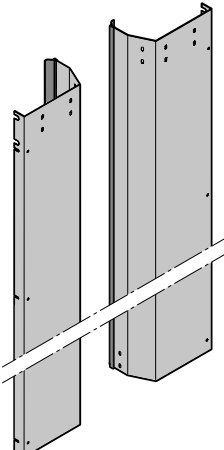
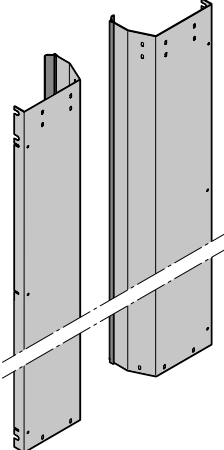

## 4. High-Speed Door HS 6015 PU V

Article	Item	Description	Production period	Art. no.	Quantity	€
	*	<b>4.1 Side element</b>			Unit(s)	
		Right	01.08.2013 – 31.12.2015	4991587	_____	/ each
		Left	01.08.2013 – 31.12.2015	4991588	_____	/ each
	*	<b>4.2 Cover, 1-part</b>			Unit(s)	
		LDH ≤ 2000 mm Right	01.08.2013 – 31.12.2015	4991416	_____	/ m / each
		Left	01.08.2013 – 31.12.2015	4991420	_____	/ m / each
	*	<b>4.3 Top cover, 2-part</b>			Unit(s)	
		LDH ≤ 3000 mm Right	01.08.2013 – 31.12.2015	4991417	_____	/ m / each
		Left	01.08.2013 – 31.12.2015	4991421	_____	/ m / each



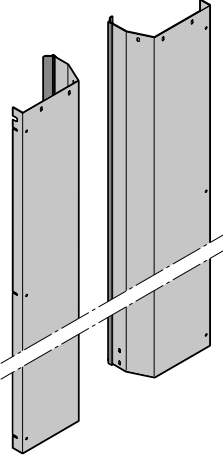
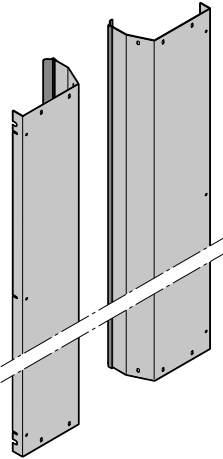
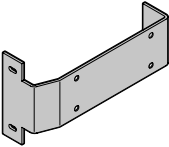

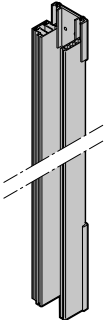
\* State purchase order number  
Surcharge for high-quality wet coating panel (see page 173)

## 4. High-Speed Door HS 6015 PU V

Article	Item	Description	Production period	Art. no.	Quantity	€
	*	<b>4.4 Bottom cover, 2-part</b>			Unit(s)	
		LDH ≤ 3000 mm Right	01.08.2013 – 31.12.2015	4991418	_____	/ m / each
		Left	01.08.2013 – 31.12.2015	4991422	_____	/ m / each
	*	<b>4.5 Centre cover, 3-part</b>			Unit(s)	
		LDH > 3000 mm Right	01.08.2013 – 31.12.2015	4991419	_____	/ m / each
		Left	01.08.2013 – 31.12.2015	4991423	_____	/ m / each
		<b>4.6 Cover bar</b>	01.08.2013 – 31.12.2015	4990830	Unit(s) _____	/ each
 50x		<b>4.7 Self-tapping screws M6 x 12</b> Screws for cover		4992181	Unit(s) _____	/ each
	*	<b>4.8 Complete aluminium profile guide</b>			Unit(s)	
		Right	01.08.2013 – 31.12.2015	4991470	_____	/ m / each
		Left	01.08.2013 – 31.12.2015	4991471	_____	/ m / each

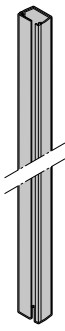
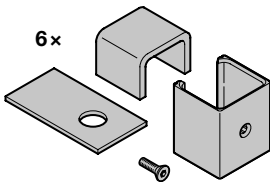

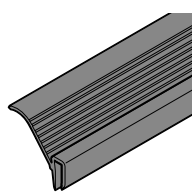
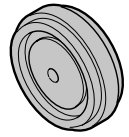
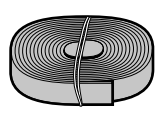

\* State purchase order number  
Surcharge for high-quality wet coating panel (see page 173)

## 4. High-Speed Door HS 6015 PU V

Article	Item	Description	Production period	Art. no.	Quantity	€
	*	<b>4.9 Light grille</b> For article numbers and lengths see pages 176 – 178 light grille / cable concept	01.08.2013 – 31.12.2015		Unit(s) _____	/ each
	6x	<b>4.10 Holder for light grille</b>	01.08.2013 – 31.12.2015	4981440	Unit(s) _____	/ each
		<b>4.11 Cable, light grille, grey, 15 m</b> Receiver always fitted on left, only FUEH	01.08.2013 – 31.05.2015	4990759	Unit(s) _____	/ each
		<b>4.12 Cable, light grille, black, 15 m</b> Transmitter always fitted on right, only FUEH	01.08.2013 – 31.05.2015	4990760	Unit(s) _____	/ each
	*	<b>4.13 Snap cable, white, light grille</b> For article numbers and lengths see pages 176 – 178 light grille / cable concept	01.06.2015 – 31.12.2015		Unit(s) _____	/ each
	*	<b>4.14 Seal for guide</b> Additional 2 x per side element required  4000 mm 5000 mm 6000 mm	01.03.2011 – 31.05.2015 01.03.2011 – 31.05.2015 01.03.2011 – 31.05.2015	4991585 4991586 4991490	Unit(s) _____ _____ _____	/ each / each / each
		<b>4.15 Roller</b> For the counter weight	01.08.2013 – 31.12.2015	159413	Unit(s) _____	/ each
		<b>4.16 Flat belt 30 mm</b> For curtain and weight 2 x LDH + 1200 mm serves as a calculation aid	01.08.2013 – 31.12.2015	4991432	Unit(s) _____	/ m

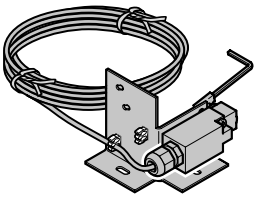
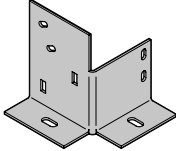

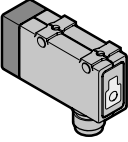
\* State purchase order number  
Surcharge for high-quality wet coating panel (see page 173)

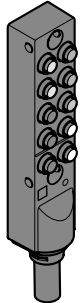
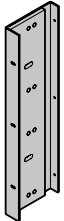
## 4. High-Speed Door HS 6015 PU V

Article	Item	Description	Production period	Art. no.	Quantity	€
	<b>4.17 Counter weight button with wiring snapM8</b>				Unit(s)	
	Right		01.08.2013 –	4980425	_____	/ each
	Left		01.08.2013 –	4980424	_____	/ each
	<b>4.18 Button support</b>		01.03.2011 –	4991131	Unit(s) _____	/ each
	* <b>4.19 Snap cable</b>				Unit(s)	
	blue, spring / counter weight yellow, belt monitoring For article numbers and lengths see pages 176 – 178 light grille / cable concept		01.06.2015 – 31.12.2015 01.06.2015 – 31.12.2015		_____ _____	/ each / each
	<b>4.20 Light button reflection</b>				Unit(s)	
	Discontinued articles The support bracket of the existing switch is not compatible with the new switch. You need the new support bracket to replace the switch (7992042, €9.60). For curtain belt monitoring		01.08.2013 – 31.12.2015 01.08.2013 – 31.12.2015	4991409 4982897	_____ _____	/ each / each
	<b>4.21 Bridge plug snap8</b>		01.06.2015 – 31.12.2015	4980188	Unit(s) _____	/ each
	* <b>4.22 Distributor 10 x M8 snap</b>				Unit(s)	
	For article numbers and lengths see pages 176 – 178 light grille / cable concept		01.06.2015 – 31.12.2015		_____	/ each
	<b>4.23 Complete operator support bracket</b>		01.08.2013 – 31.12.2015	4990800	Unit(s) _____	/ each

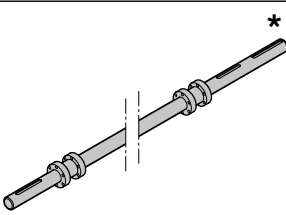
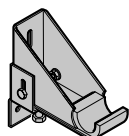
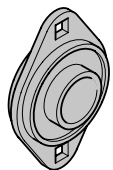
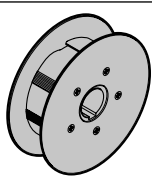
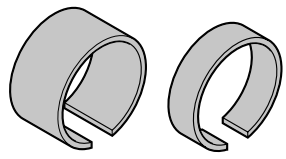

\* State purchase order number  
Surcharge for high-quality wet coating panel (see page 173)

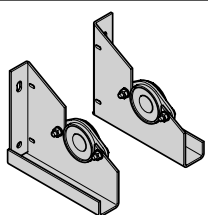
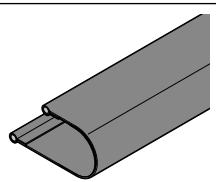
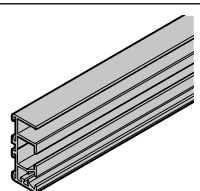
## 4. High-Speed Door HS 6015 PU V

Article	Item	Description	Production period	Art. no.	Quantity	€
	<b>4.24</b>	<b>Complete shaft</b>	01.08.2013 – 31.12.2015	4991607	Unit(s) _____	/ m / each
	<b>4.25</b>	<b>Shaft support</b>	01.08.2013 – 31.12.2015	4990877	Unit(s) _____	/ each
	<b>4.26</b>	<b>Grooved ball-bearing ASPFL 208</b>	01.08.2013 – 31.12.2015	159403	Unit(s) _____	/ each
	<b>4.27</b>	<b>Pulley Ø 145</b>	01.08.2013 – 31.12.2015	4991433	Unit(s) _____	/ each
	<b>4.28</b>	<b>distance sleeve</b> L 10 mm L 30 mm	01.08.2013 – 31.12.2015 01.08.2013 – 31.12.2015	4991703 4991805	Unit(s) _____ _____	/ each / each
	<b>4.29</b>	<b>Adjusting ring</b>	01.08.2013 – 31.12.2015	159163	Unit(s) _____	/ each
	<b>4.30</b>	<b>Complete bearing support</b> Right Left	01.08.2013 – 31.12.2015 01.08.2013 – 31.12.2015	4991425 4991424	Unit(s) _____ _____	/ each / each
	<b>4.31</b>	<b>Curtain loop complete</b> 80, without ThermoFrame 100, with ThermoFrame	01.08.2013 – 31.12.2015 01.08.2013 – 31.12.2015	4991415 4991342	Unit(s) _____ _____	/ m / m
	<b>4.32</b>	<b>Sealing frame channel</b> 4000 mm 5000 mm 6000 mm	01.08.2013 – 31.12.2015 01.08.2013 – 31.12.2015 01.08.2013 – 31.12.2015	4991263 4991770 4991426	Unit(s) _____ _____ _____	/ each / each / each

\* State purchase order number  
Surcharge for high-quality wet coating panel (see page 173)

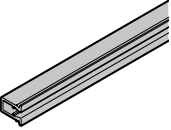
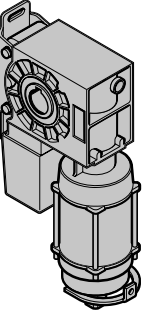
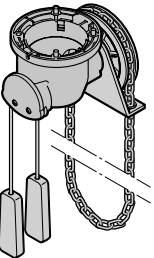
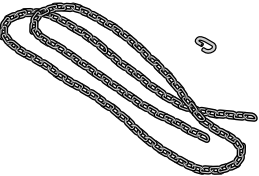
## 4. High-Speed Door HS 6015 PU V

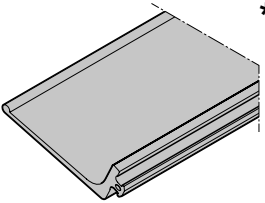
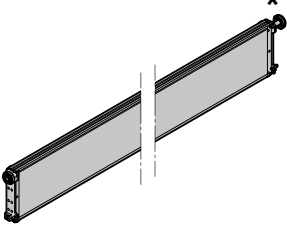
Article	Item	Description	Production period	Art. no.	Quantity	€
	*	<b>4.33 Sealing frame clips</b>			Unit(s)	
		4000 mm	01.08.2013 – 31.12.2015	4991264	_____	/ each
		5000 mm	01.08.2013 – 31.12.2015	4991771	_____	/ each
		6000 mm	01.08.2013 – 31.12.2015	4991427	_____	/ each
	*	<b>4.34 Operator</b>	01.08.2013 – 31.12.2015		Unit(s)	/ each
		<b>4.35 Emergency hand chain gearbox</b>	01.08.2013 – 31.12.2015	158171	Unit(s)	/ each
		<b>4.36 hand chain 10 m</b> With chain link	01.08.2013 – 31.12.2015	4982733	Unit(s)	/ each
		<b>4.37 Brake 11 Nm</b>			Unit(s)	
		+ 103 V	01.08.2013 – 31.05.2015	157686	_____	/ each
		24 V LH U	01.06.2015 – 31.12.2015	4982120	_____	/ each
	*	<b>4.38 Panel lintel seal</b>	01.08.2013 – 31.12.2015	4991790	Unit(s)	/ m
	*	<b>4.39 Complete top panel</b>	01.08.2013 – 31.12.2015	4991661	Unit(s)	/ m
		Section height: 225 mm Standard version: RAL 9006			_____	/ each

\* State purchase order number  
Surcharge for high-quality wet coating panel (see page 173)

## 4. High-Speed Door HS 6015 PU V

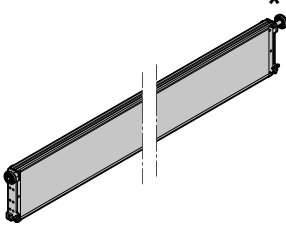
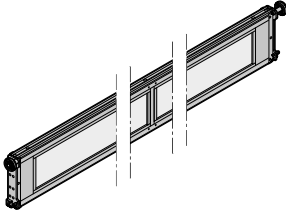
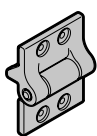
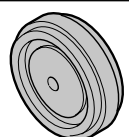
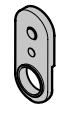
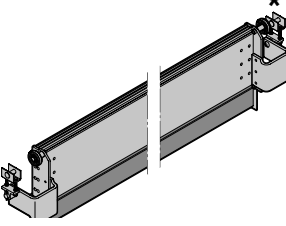
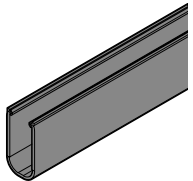
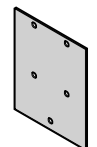
Article	Item	Description	Production period	Art. no.	Quantity	€
	*	<b>4.40 Inclination panel</b> Section height: 225 mm Standard version: RAL 9006	01.08.2013 – 31.12.2015	4990820	Unit(s) _____	/ m / each
	*	<b>4.41 Complete window profile</b> Double glazing Triple glazing Section height: 225 mm Standard version: RAL 9006	01.08.2013 – 31.12.2015 01.08.2013 – 31.12.2015	4990819 4990819	Unit(s) _____ _____	/ m / each / m / each
		<b>4.42 Complete centre hinge</b> With screws black Silver	01.08.2013 – 31.12.2015 01.08.2013 – 31.12.2015	4990838 4990797	Unit(s) _____ _____	/ each / each
		<b>4.43 Roller with band</b> For panels	01.08.2013 – 31.12.2015	4990818	Unit(s) _____	/ each
		<b>4.44 Complete hinge connector</b>	01.08.2013 – 31.12.2015	4981937	Unit(s) _____	/ each
	*	<b>4.45 Bottom part Complete</b>	01.08.2013 – 31.12.2015	4991581	Unit(s) _____	/ m / each
	*	<b>4.46 Rubber profile Velcro strap</b> (additionally required: Velcro strap 1 m)	01.08.2013 – 31.12.2015 01.03.2011 –	306843 159601	Unit(s) _____ _____	/ m / m
		<b>4.47 UPVC canopy</b>	01.08.2013 – 31.12.2015	4991720	Unit(s) _____	/ each

\* State purchase order number  
Surcharge for high-quality wet coating panel (see page 173)

## 4. High-Speed Door HS 6015 PU V

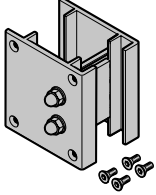
Article	Item Description	Production period	Art. no.	Quantity	€
	<b>4.48 Fixing clip</b> To hold the curtain in place when exchanging panels	01.08.2013 – 31.12.2015	4990854	Unit(s) _____	/ each

\* State purchase order number  
 Surcharge for high-quality wet coating panel (see page 173)

# HS 7030 PU 42

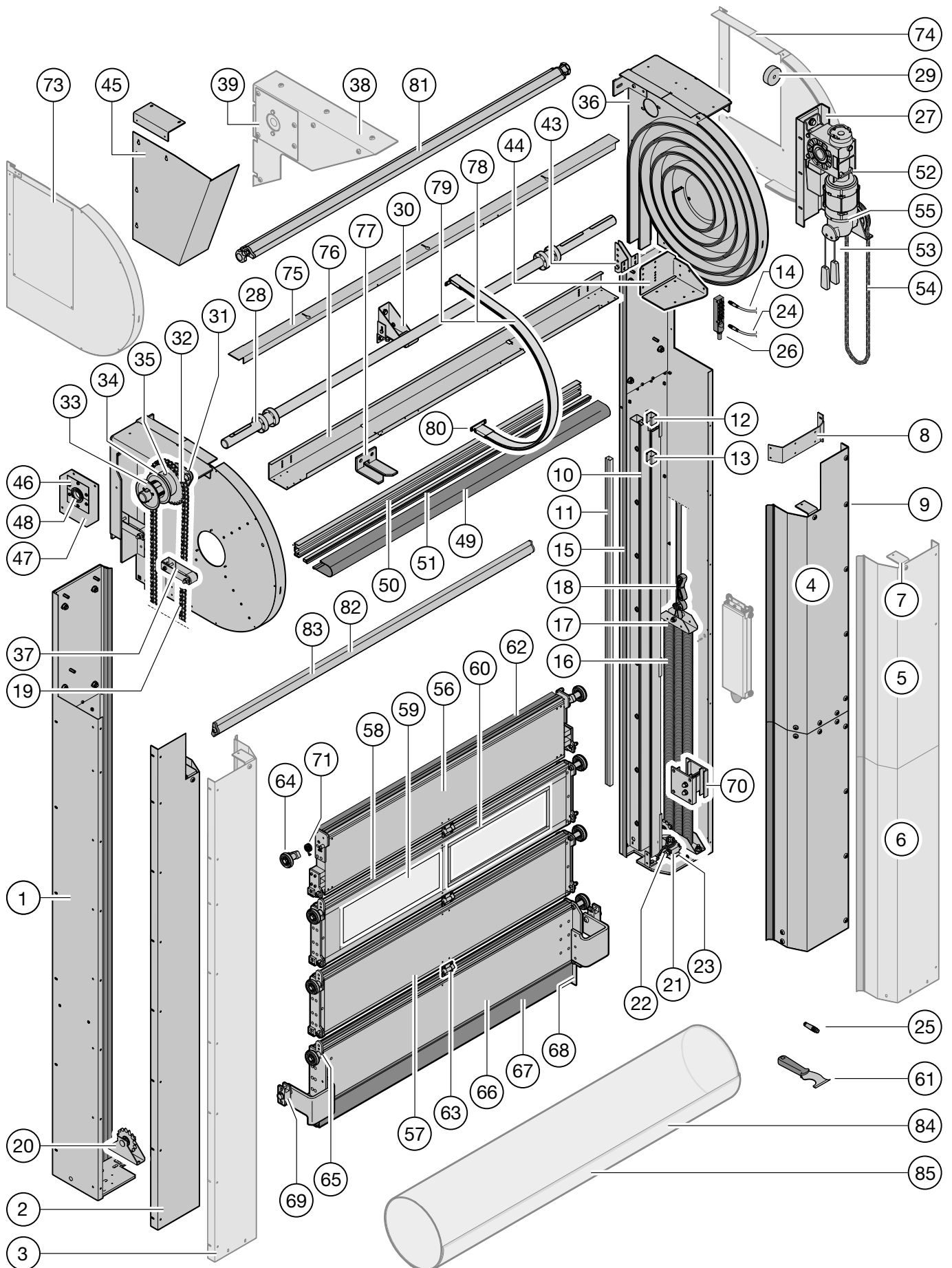

# 5. High-Speed Door HS 7030 PU 42

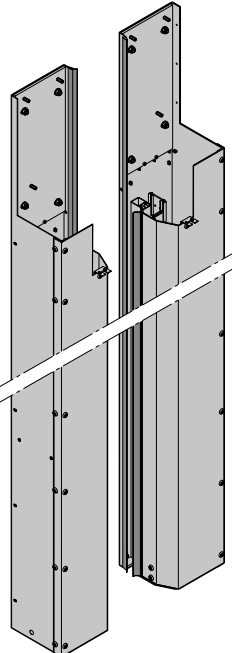
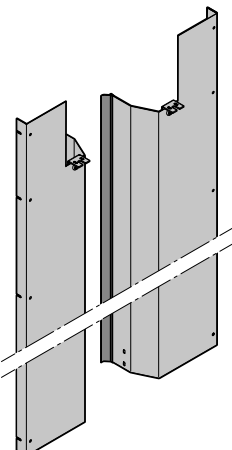
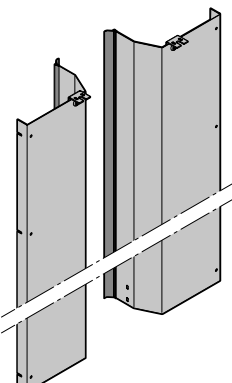
Article	Item	Description	Production period	Art. no.	Quantity	€
	* 5.1	<b>Side element</b>			Unit(s)	
		Right	01.01.2016 –	4980572	_____	/ each
		Left	01.01.2016 –	4980573	_____	/ each
	* 5.2	<b>Cover, 1-part</b>			Unit(s)	
		LDH ≤ 3250 mm, without cladding				
		Right	01.01.2016 –	4980574	_____	/ m
		Left	01.01.2016 –	4980576	_____	/ m
	* 5.3	<b>Cover, 1-part</b>			Unit(s)	
		LDH ≤ 3250 mm, with cladding				
		Right	01.01.2016 –	4980575	_____	/ m
		Left	01.01.2016 –	4980577	_____	/ m



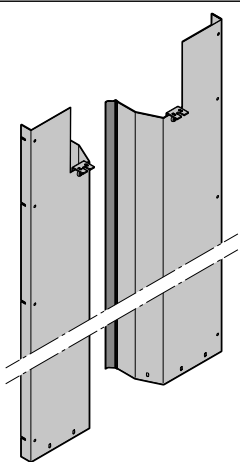
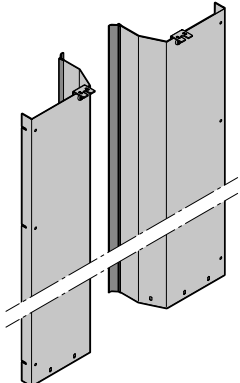
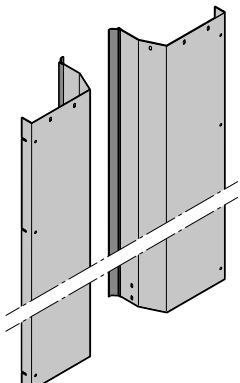
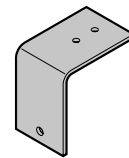
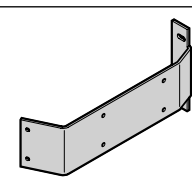

\* State purchase order number  
 Surcharge for high-quality wet coating panel (see page 173)

## 5. High-Speed Door HS 7030 PU 42

Article	Item	Description	Production period	Art. no.	Quantity	€
	* 5.4	<b>Top cover, 2-part</b>			Unit(s)	
		LDH > 3250 mm, without cladding				
		Right	01.01.2016 –	4980578	_____	/ m
		Left	01.01.2016 –	4980581	_____	/ each
	* 5.5	<b>Top cover, 2-part</b>			Unit(s)	
		LDH > 3250 mm, with cladding				
		Right	01.01.2016 –	4980579	_____	/ m
		Left	01.01.2016 –	4980659	_____	/ each
	* 5.6	<b>Bottom cover, 2-part</b>			Unit(s)	
		LDH > 3250 mm, without cladding				
		Right	01.01.2016 –	4980580	_____	/ m
		Left	01.01.2016 –	4980583	_____	/ each
	5.7	<b>Cover support bracket</b>			Unit(s)	
		3-sided without cladding				
			01.01.2016 – 31.12.2018	4980584	_____	/ each
			01.01.2019 – 31.05.2025	4981748	_____	/ each
		2-sided with cladding				
		01.01.2016 – 31.12.2018	4981180	_____	/ each	
		01.01.2019 – 31.05.2025	4981747	_____	/ each	
		01.06.2025 –	7992712	_____	/ each	
	5.8	<b>Cover bar</b>	01.01.2016 –	4991910	Unit(s)	/ each

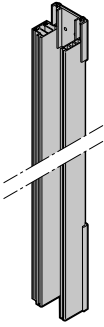

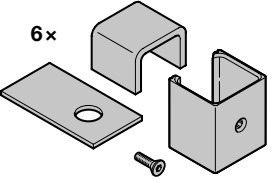
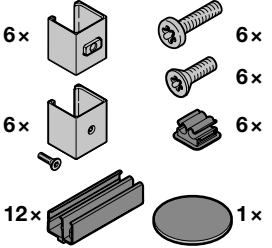
\* State purchase order number  
 Surcharge for high-quality wet coating panel (see page 173)

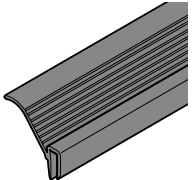
## 5. High-Speed Door HS 7030 PU 42

Article	Item	Description	Production period	Art. no.	Quantity	€
	50x	<b>5.9 Self-tapping screws M6 x 12</b> Screws for cover		4992181	Unit(s) _____	/ each
	*	<b>5.10 Complete aluminium profile guide</b>  Right  Left	01.01.2016 –  01.01.2016 –	4980585  4980586	Unit(s) _____  _____	/ m / each / m / each
	*	<b>5.11 Light grille</b>  For article numbers and lengths see pages 176 – 178 light grille / cable concept	01.01.2016 – 31.05.2021 01.06.2021 –		Unit(s) _____  _____	/ each / each
	6x	<b>5.12 Holder for light grille</b>	01.01.2017 – 31.05.2021	4981440	Unit(s) _____	/ each
	6x 6x 12x	<b>5.13 Light grille replacement accessories</b> From 01.06.2021 onwards, the bag is required when replacing the light grille.	01.06.2021 –	4982111	Unit(s) _____	/ each
	*	<b>5.14 Snap cable, white, light grille</b> For article numbers and lengths see pages 176 – 178 light grille / cable concept	01.01.2016 –		Unit(s) _____	/ each
	*	<b>5.15 Seal for guide</b> Additional 2 x per side element required  4000 mm 5000 mm 6000 mm	01.01.2016 – 01.01.2016 – 01.01.2016 –	4991585 4991586 4991490	Unit(s) _____  _____  _____	/ each / each / each



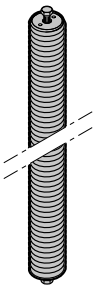
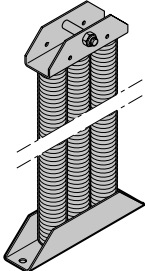
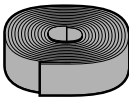

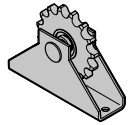
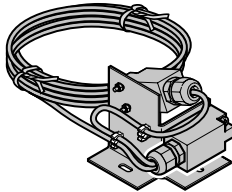
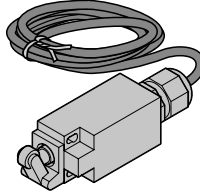
\* State purchase order number  
Surcharge for high-quality wet coating panel (see page 173)

## 5. High-Speed Door HS 7030 PU 42

Article	Item	Description	Production period	Art. no.	Quantity	€
	*	<b>5.16 Single spring</b>	01.01.2016 –		Unit(s) _____	/each
	*	<b>5.17 Complete spring assembly</b> Right Left	01.01.2016 – 01.01.2016 –		Unit(s) _____ _____	/each /each
	*	<b>5.18 Belt</b> 3950 mm 5200 mm 7200 mm LDH + 300 mm serves as a calculation aid	01.01.2016 – 01.01.2016 – 01.01.2016 –	4990496 4990495 4990494	Unit(s) _____ _____ _____	/each /each /each
	*	<b>5.19 Roller chain reinforced</b>	01.01.2016 –	159568	m _____	/ m
		<b>5.20 Complete chain tensioner wheel</b> Right Left	01.01.2016 – 01.01.2016 –	4990809 4990810	Unit(s) _____ _____	/each /each
		<b>5.21 Button with wiring</b> For spring and chain monitoring Right Left	01.01.2016 – 01.01.2016 –	4980327 4980337	Unit(s) _____ _____	/each /each
		<b>5.22 Chain test button</b> For chain monitoring Right Left	01.01.2016 – 01.01.2016 –	4992012 4992011	Unit(s) _____ _____	/each /each

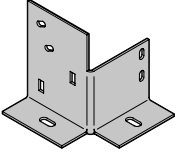

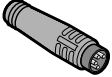
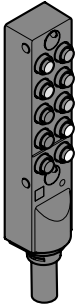
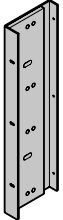
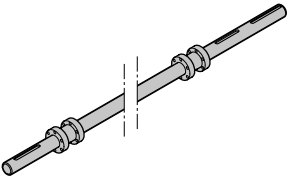
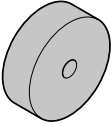
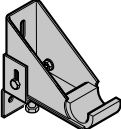
\* State purchase order number  
Surcharge for high-quality wet coating panel (see page 173)

## 5. High-Speed Door HS 7030 PU 42

Article	Item	Description	Production period	Art. no.	Quantity	€
	<b>5.23</b>	<b>Button support</b> Right Left	01.01.2016 – 01.01.2016 –	4991130 4991131	Unit(s) _____ _____	/ each / each
	*	<b>5.24 Snap cable</b> <b>blue, spring / counter weight</b> For article numbers and lengths see pages 176 – 178 light grille / cable concept	01.01.2016 –		Unit(s) _____	/ each
		<b>5.25 Bridge plug snap 8</b>	01.01.2016 –	4980188	Unit(s) _____	/ each
	*	<b>5.26 Distributor 10 x M8 snap</b> For article numbers and lengths see pages 176 – 178 light grille / cable concept	01.01.2016 –		Unit(s) _____	/ each
		<b>5.27 Complete operator support bracket</b>	01.01.2016 –	4990800	Unit(s) _____	/ each
	*	<b>5.28 Complete shaft</b>	01.01.2016 – 31.12.2018 01.01.2019 –	4980587 4981527	Unit(s) _____ _____ _____	/ m / each / m / each
		<b>5.29 Spacer</b>	01.01.2019 –	4990829	Unit(s) _____	/ each
		<b>5.30 Shaft support</b>	01.01.2016 –	4990877	Unit(s) _____	/ each
		<b>5.31 Grooved ball-bearing ASPFL 208</b>	01.01.2016 –	159403	Unit(s) _____	/ each

\* State purchase order number  
Surcharge for high-quality wet coating panel (see page 173)

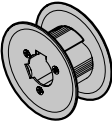
## 5. High-Speed Door HS 7030 PU 42

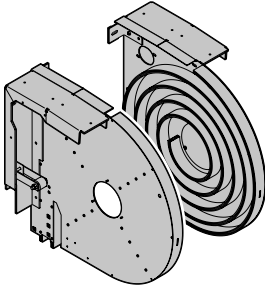
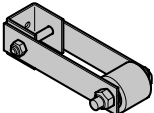
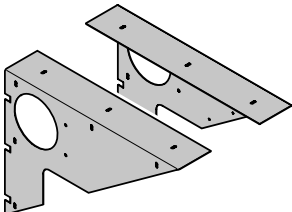
Article	Item Description	Production period	Art. no.	Quantity	€
	<b>5.32 Chain sprocket</b>	01.01.2016 –	4990808	Unit(s) _____	/ each
	<b>5.33 Guide roller Ø 70</b>	01.01.2016 –	4981037	Unit(s) _____	/ each
	<b>5.34 Distance sleeve 10 mm</b>	01.01.2016 –31.12.2018 01.01.2019 –	4991703 4981647	Unit(s) _____	/ each
	<b>5.35 Adjusting ring</b>	01.01.2016 –	159163	Unit(s) _____	/ each
	<b>* 5.36 Complete spiral support</b>			Unit(s)	
	Right, LDH ≤ 4500	01.01.2016 – 31.12.2018 01.01.2019 – 31.05.2025	4980588 4981648	_____ _____	/ each / each
	Left, LDH ≤ 4500	01.06.2025 – 01.01.2016 – 31.12.2018	7992772 4980589	_____ _____	/ each / each
	Right, LDH ≤ 5500	01.01.2019 – 31.05.2025 01.06.2025 –	4981649 7992773	_____ _____	/ each / each
	Left, LDH ≤ 5500	01.01.2016 – 31.12.2018 01.01.2019 – 31.05.2025	4980590 4981650	_____ _____	/ each / each
	Right, LDH ≤ 6500	01.06.2025 – 01.01.2016 – 31.12.2018	7992774 4980591	_____ _____	/ each / each
	Left, LDH ≤ 6500	01.01.2019 – 31.05.2025 01.06.2025 –	4981651 7992775	_____ _____	/ each / each
	Right, LDH ≤ 6500	01.01.2016 – 31.12.2018 01.01.2019 – 31.05.2025	4980592 4981652	_____ _____	/ each / each
	Left, LDH ≤ 6500	01.06.2025 – 01.01.2016 – 31.12.2018	7992776 4980593	_____ _____	/ each / each
	01.01.2019 – 31.05.2025 01.06.2025 –	4981653 7992777	_____ _____	/ each / each	
	<b>5.37 Complete return pulley</b>	01.01.2016 –	4991214	Unit(s) _____	/ each
	<b>5.38 Support sheet with cladding</b>			Unit(s)	
	<b>Right</b> , operator left <b>Left</b> , operator right	01.01.2016 – 01.04.2017 01.01.2016 – 01.04.2017	4990834 4990835	_____ _____	/ each / each

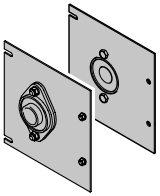
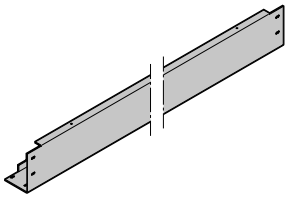
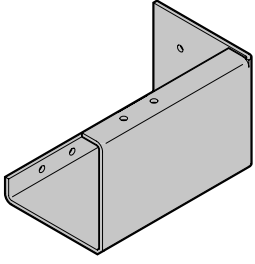
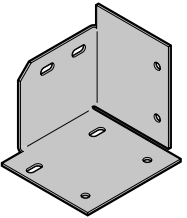
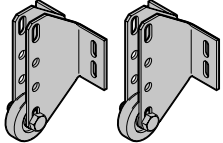
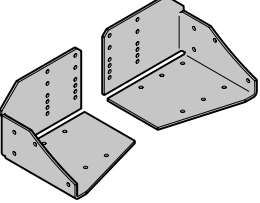

\* State purchase order number  
Surcharge for high-quality wet coating panel (see page 173)

## 5. High-Speed Door HS 7030 PU 42

Article	Item	Description	Production period	Art. no.	Quantity	€
	<b>5.39 Complete inspection cover with bearing and cladding</b>				Unit(s)	
	<b>Right</b> , operator left <b>Left</b> , operator right	01.01.2016 – 01.04.2017 01.01.2016 – 01.04.2017	4990842 4990843	_____ _____	/ each / each	
	<b>* 5.40 Reinforcement profile</b>				Unit(s)	
	Without cladding	01.01.2016 – 31.12.2018	4980594	_____	/ m	
		01.01.2019 – 31.05.2025	4981685	_____	/ m	
	With cladding	01.01.2016 – 31.12.2018	4981050	_____	/ m	
		01.01.2019 – 31.05.2025	4981686	_____	/ m	
	Rear (3-sided cladding only)	01.01.2016 – 31.12.2018	4992168	_____	/ m	
		01.01.2019 – 31.05.2025	4981687	_____	/ m	
	<b>5.41 Reinforcement profile support</b>		01.01.2019 – 31.05.2025	4981654	Unit(s)	/ each
	<b>5.42 Rear reinforcement profile (for 3-sided cladding only)</b>				Unit(s)	
	Right	01.01.2016 – 31.12.2018	4991397	_____	/ each	
		01.01.2019 – 31.05.2025	4981724	_____	/ each	
	Left	01.01.2016 – 31.12.2018	4991398	_____	/ each	
		01.01.2019 – 31.05.2025	4981725	_____	/ each	
	<b>5.43 Complete pressure roller</b>		01.01.2016 – 31.12.2018	4992183	Unit(s)	/ each
	(2 units)	01.01.2019 –	4981632	_____	/ each	
	<b>5.44 Reinforcement profile support</b>				Unit(s)	
	Used without cladding and 2-sided cladding. In the case of 3-sided cladding, the reinforcement profile support takes over this function. 1)					
	<b>1)</b>	01.01.2016 – 31.12.2018	4991849	_____	/ each	
	<b>1)</b>	01.01.2019 – 31.05.2025	4981726	_____	/ each	
	Right	01.06.2025 –	7992709	_____	/ each	
Left	01.06.2025 –	7992710	_____	/ each		

\* State purchase order number  
Surcharge for high-quality wet coating panel (see page 173)

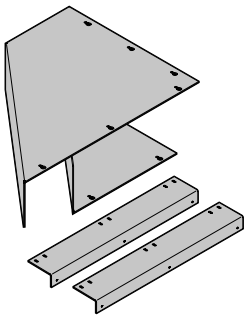
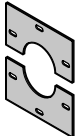
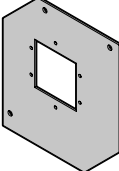
## 5. High-Speed Door HS 7030 PU 42

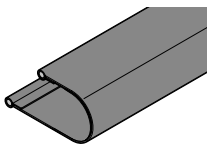
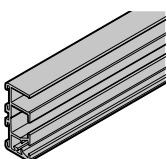
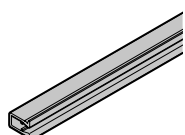
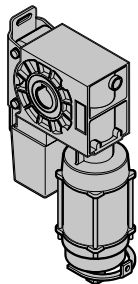
Article	Item	Description	Production period	Art. no.	Quantity	€
	*	<b>5.45 Cladding, complete</b>	01.01.2016 – 31.05.2025 01.06.2025 –	4980360 7992790	Unit(s) _____ _____	/ each / each
		<b>5.46 Retaining plate for bearing</b> per door (2 units)	01.04.2017 –	4981284	Unit(s) _____	/ each
		<b>5.47 Sheet bearing</b> For doors before 31.12.2018, new holes must be drilled on site.	01.01.2019 –	4981655	Unit(s) _____	/ each
		<b>5.48 Ball-bearing with groove</b>	01.04.2017 –	158993	Unit(s) _____	/ each
	*	<b>5.49 Curtain loop complete</b> 80, without ThermoFrame 100, with ThermoFrame	01.01.2016 – 01.01.2016 –	4991415 4991342	Unit(s) _____ _____	/ m / m
	*	<b>5.50 Sealing frame channel</b> 4000 mm 5000 mm 6000 mm	01.01.2016 – 01.01.2016 – 01.01.2016 –	4991263 4991770 4991426	Unit(s) _____ _____ _____	/ each / each / each
	*	<b>5.51 Sealing frame clips</b> 4000 mm 5000 mm 6000 mm	01.01.2016 – 01.01.2016 – 01.01.2016 –	4991264 4991771 4991427	Unit(s) _____ _____ _____	/ each / each / each
	*	<b>5.52 Operator</b>			Unit(s) _____	/ each

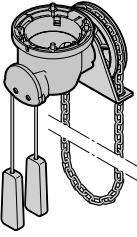
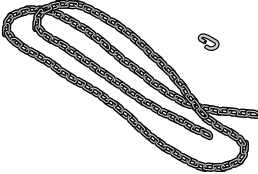
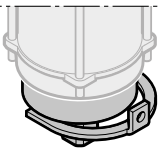
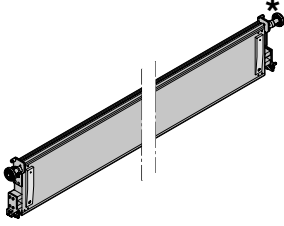
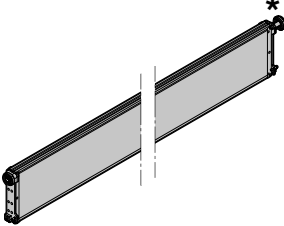
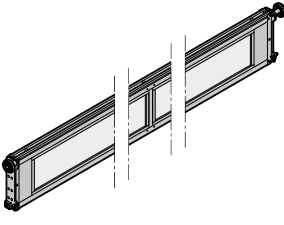
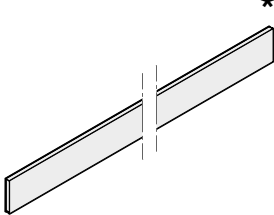

\* State purchase order number  
Surcharge for high-quality wet coating panel (see page 173)

## 5. High-Speed Door HS 7030 PU 42

Article	Item	Description	Production period	Art. no.	Quantity	€
	<b>5.53</b>	<b>Emergency hand chain gearbox</b>	01.01.2016 –	158171	Unit(s) _____	/ each
	<b>5.54</b>	<b>hand chain 10 m</b> With chain link	01.01.2016 –	4982733	Unit(s) _____	/ each
	<b>5.55</b>	<b>Brake 11 Nm</b> <b>24 V LH U</b>	01.06.2016 –	4982120	Unit(s) _____	/ each
	<b>5.56</b>	<b>Top panel, complete with alignment mechanism</b>  Section height: 250 mm Standard version: RAL 9006	01.01.2016 –	4980597	Unit(s) _____	/ m / each
	<b>5.57</b>	<b>Inclination panel</b>  Section height: 250 mm Standard version: RAL 9006	01.01.2016 –	4980567	Unit(s) _____	/ m / each
	<b>5.58</b>	<b>Complete window profile</b>  Double glazing Triple glazing  Section height: 250 mm Standard version: RAL 9006	01.01.2016 – 01.01.2016 –	4980565 4980565	Unit(s) _____ _____	/ m / each / m / each
	<b>5.59</b>	<b>Double pane</b> Section height: 250 mm	01.01.2016 –		Unit(s) _____	/ each

\* State purchase order number  
Surcharge for high-quality wet coating panel (see page 173)

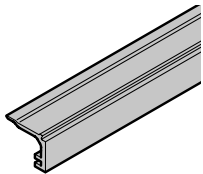
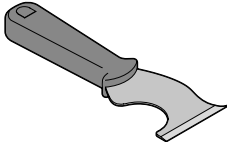
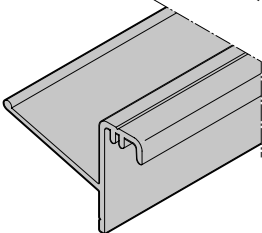
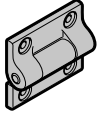
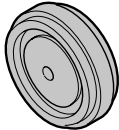
## 5. High-Speed Door HS 7030 PU 42

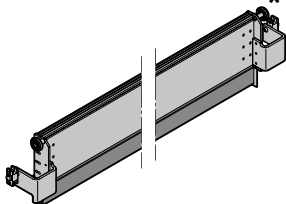
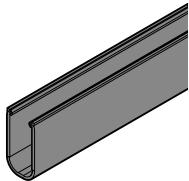
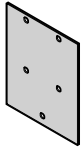
Article	Item	Description	Production period	Art. no.	Quantity	€
	*	<b>5.60 Glazing bead</b> Short, 160.8 mm long, per / m	01.01.2016 – 01.01.2016 –	4992192 4992194	Unit(s) _____ _____	/ each / m
		<b>5.61 Hand scraper</b>	01.01.2016 –	4981136	Unit(s) _____	/ each
	*	<b>5.62 Panel lintel seal</b>	01.01.2016 –	4991922	Unit(s) _____	/ each
		<b>5.63 Complete centre hinge</b> With screws  black Silver	01.01.2016 – 01.01.2016 –	4991905 4991904	Unit(s) _____ _____	/ each / each
		<b>5.64 Roller with band</b> For panels	01.01.2016 –	4990818	Unit(s) _____	/ each
		<b>5.65 Complete hinge connector</b>	01.01.2016 –	4981937	Unit(s) _____	/ each
	*	<b>5.66 Bottom part Complete</b>	01.01.2016 –	4980600	Unit(s) _____	/ m / each
	*	<b>5.67 Rubber profile Velcro strap</b> (additionally required: Velcro strap 1 m)	01.01.2016 – 01.03.2011 –	4980601 159601	Unit(s) _____ _____	/ m / m
		<b>5.68 UPVC canopy</b>	01.01.2016 –	4992208	Unit(s) _____	/ each

\* State purchase order number  
Surcharge for high-quality wet coating panel (see page 173)

## 5. High-Speed Door HS 7030 PU 42

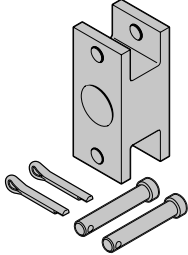
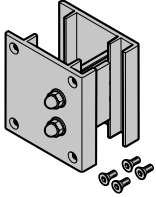
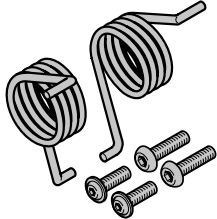
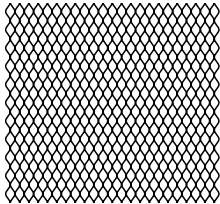
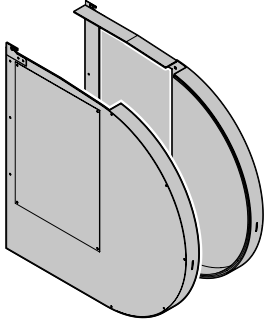
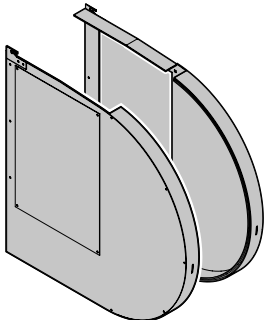
Article	Item Description	Production period	Art. no.	Quantity	€
	<b>5.69 Complete chain connection</b>	01.01.2016 –	4990824	Unit(s) _____	/ each
	<b>5.70 Fixing clip</b> To hold the curtain in place when exchanging panels	01.01.2016 –	4990854	Unit(s) _____	/ each
	<b>5.71 Replacement of leg springs</b>	01.01.2016 –	4981012	Unit(s) _____	/ each
	<b>5.72 Ventilation grille</b>	01.05.2017 –	4981282	Unit(s) _____	/ m. / each
	<p><b>* 5.73 Side cover</b> For cladding</p> <p><b>right, operator</b> right LDB ≤ 4500 mm left LDB ≤ 4500 mm right LDB ≤ 5500 mm left LDB ≤ 5500 mm right LDB ≤ 6500 mm left LDB ≤ 6500 mm Self-tapping screws M6 × 12 required (see item 5.9)</p>	<p>01.06.2025 – 01.06.2025 – 01.06.2025 – 01.06.2025 – 01.06.2025 – 01.06.2025 –</p>	<p>7992784 7992785 7992786 7992787 7992788 7992789</p>	<p>Unit(s) _____ _____ _____ _____ _____ _____</p>	<p>/ each / each / each / each / each / each</p>
	<p><b>* 5.74 Side cover</b> For cladding</p> <p><b>left, operator</b> right LDB ≤ 4500 mm left LDB ≤ 4500 mm right LDB ≤ 5500 mm left LDB ≤ 5500 mm right LDB ≤ 6500 mm left LDB ≤ 6500 mm Self-tapping screws M6 × 12 required (see item 5.9)</p>	<p>01.06.2025 – 01.06.2025 – 01.06.2025 – 01.06.2025 – 01.06.2025 – 01.06.2025 –</p>	<p>7992929 7992930 7992902 7992903 7992933 7992934</p>	<p>Unit(s) _____ _____ _____ _____ _____ _____</p>	<p>/ each / each / each / each / each / each</p>

\* State purchase order number  
Surcharge for high-quality wet coating panel (see page 173)

## 5. High-Speed Door HS 7030 PU 42

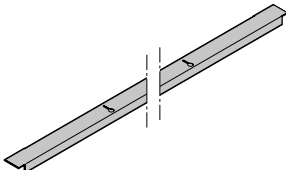
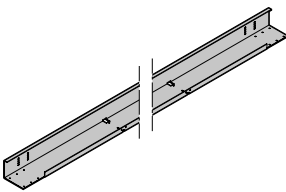
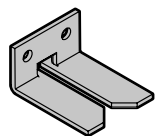
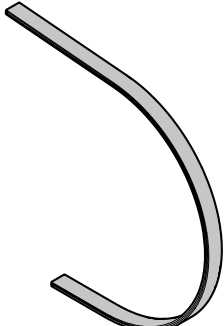
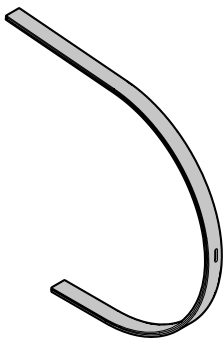
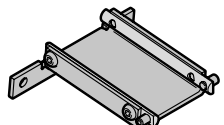
Article	Item Description	Production period	Art. no.	Quantity	€
	<p><b>* 5.75 Reinforcement profile</b></p> <p>top, without cladding</p>	01.06.2025 –	7992743	Unit(s)	/ m
	<p>top cladding</p>	01.06.2025 –	7992713		/ each
	<p><b>* 5.76 Reinforcement profile</b></p> <p>bottom, without cladding</p>	01.06.2025 –	7992744	Unit(s)	/ m
	<p>bottom <sup>1)</sup> cladding</p> <p><sup>1)</sup> Threading for cladding required (see item 5.77)</p>	01.06.2025 –	7992711		/ each
	<p><b>5.77 Threading for cladding</b></p> <p>30 × 60 × 50 mm</p>	01.06.2025 –	7991484	Unit(s)	/ each
	<p>30 × 90 × 50 mm</p> <p>Self-tapping screws M6 × 12 required (see item 5.9)</p>	01.06.2025 –	7991483		/ each
	<p><b>5.78 Support yoke</b></p> <p>For cladding</p>			Unit(s)	
	<p>LDH ≤ 4500</p>	01.06.2025 –	7992766		/ each
	<p>LDH &gt; 4500, LDH ≤ 5500</p>	01.06.2025 –	7992767		/ each
	<p><b>5.79 Support yoke</b></p> <p>Without cladding</p>			Unit(s)	
	<p>LDH ≤ 4500</p>	01.06.2025 –	7992769		/ each
	<p>LDH &gt; 4500, LDH ≤ 5500</p>	01.06.2025 –	7992770		/ each
	<p><b>5.80 Connection for support yoke</b></p> <p>Self-tapping screws M6 × 12 required (see item 5.9)</p>	01.06.2025 –	7992908	Unit(s)	/ each





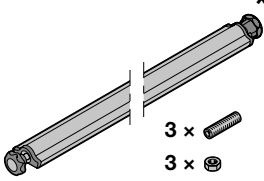
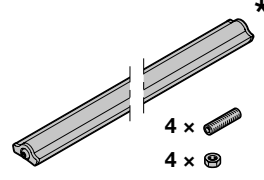
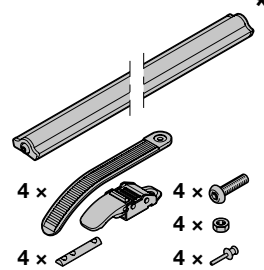
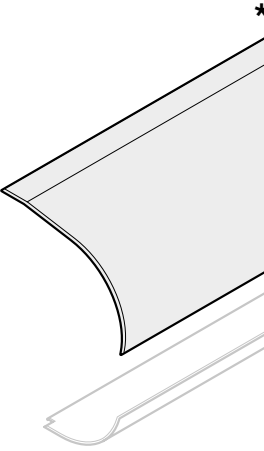
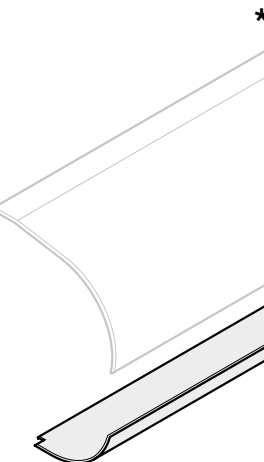

\* State purchase order number  
 Surcharge for high-quality wet coating panel (see page 173)

## 5. High-Speed Door HS 7030 PU 42

Article	Item	Description	Production period	Art. no.	Quantity	€
	<b>5.81</b>	<b>Top crossbar, complete</b>	01.06.2025 –	7992898	Unit(s) _____ _____	/ m / each
	<b>5.82</b>	<b>Centre crossbar, complete</b>	01.06.2025 –	7992899	Unit(s) _____ _____	/ m / each
	<b>5.83</b>	<b>Bottom cladding crossbar, complete</b>	01.06.2025 –	7992900	Unit(s) _____ _____	/ m / each
	<b>5.84</b>	<b>Top pane</b> For cladding  Without foil coating With foil coating Based on RAL 9006 White aluminium Based on RAL 1018 Zinc yellow Based on RAL 3002 Camine red Based on RAL 5010 Gentian blue Based on RAL 2004 Pure orange based on RAL 9005 Jet black	01.06.2025 – 01.06.2025 –	7992897 7992897	Unit(s) _____ _____	/ each / each
	<b>5.85</b>	<b>Bottom pane</b> For cladding  Without foil coating With foil coating Based on RAL 9006 White aluminium Based on RAL 1018 Zinc yellow Based on RAL 3002 Camine red Based on RAL 5010 Gentian blue Based on RAL 2004 Pure orange based on RAL 9005 Jet black	01.06.2025 – 01.06.2025 –	7992896 7992896	Unit(s) _____ _____	/ each / each

\* State purchase order number  
Surcharge for high-quality wet coating panel (see page 173)

## 5. High-Speed Door HS 7030 PU 42

Article	Item	Description	Production period	Art. no.	Quantity	€
4 x 	7 x 	<b>5.86 Accessories fixing material</b> PC cladding	01.06.2025 –	7992863	Unit(s)	/ each
6 x 	7 x 				_____	
36 x 	3 x 					

\* State purchase order number  
Surcharge for high-quality wet coating panel (see page 173)

# HS 5015 PU N 42

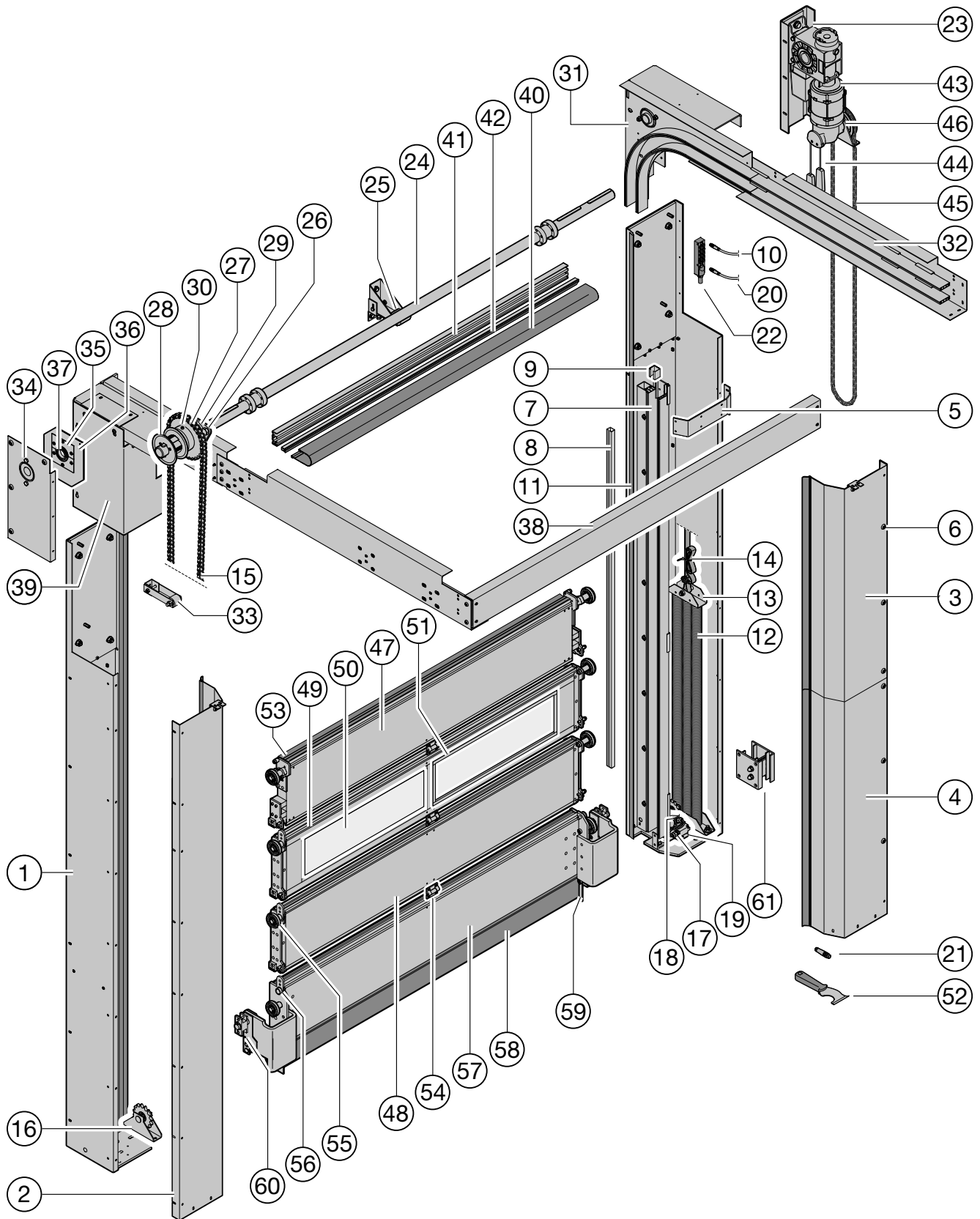

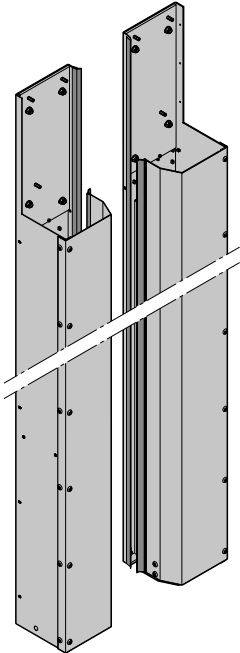
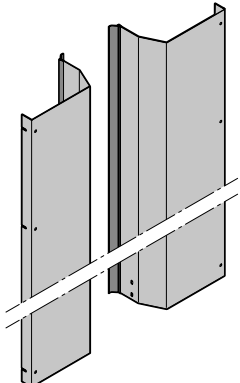
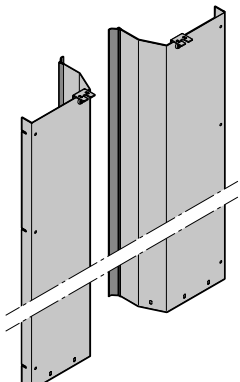

# 6. High-Speed Door HS 5015 PU N 42

Article	Item	Description	Production period	Art. no.	Quantity	€	
	* 6.1	<b>Side element</b>			Unit(s)		
		Right	01.01.2016 –	4992108	_____	/ each	
		Left	01.01.2016 –	4992109	_____	/ each	
	* 6.2	<b>Cover, 1-part</b>			Unit(s)		
		DE – DA ≥ – 3745 mm					
		Right	01.01.2016 – 31.12.2018	4980686	_____	/ m	
			01.01.2019 –	4981656	_____	/ m	
	Left	01.01.2016 – 31.12.2018	4980687	_____	/ m		
			01.01.2019 –	4981657	_____	/ m	
	* 6.3	<b>Top cover, 2-part</b>			Unit(s)		
		DE – DA ≥ 3745 – ≤ 6245 mm					
		Right	01.01.2016 – 31.12.2018	4992112	_____	/ m	
			01.01.2019 –	4981658	_____	/ m	
	Left	01.01.2016 – 31.12.2018	4992114	_____	/ m		
			01.01.2019 –	4981659	_____	/ m	

\* State purchase order number  
 Surcharge for high-quality wet coating panel (see page 173)  
 EN Ceiling height  
 DA Distance to ceiling

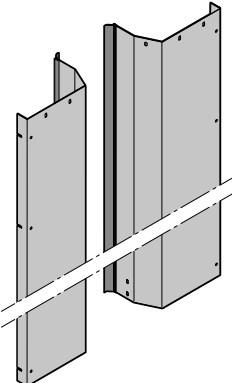
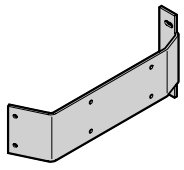
## 6. High-Speed Door HS 5015 PU N 42

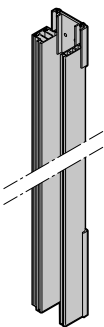
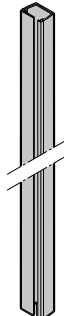
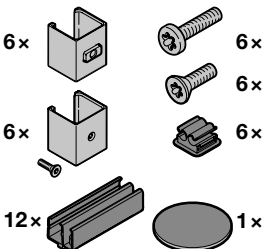
Article	Item	Description	Production period	Art. no.	Quantity	€
	* 6.4	<b>Bottom cover, 2-part</b>			Unit(s)	
		DE – DA $\geq 3745$ – $\leq 6245$ mm	01.01.2016 –	4992113	_____	/ m
		Right	01.01.2016 –	4992113	_____	/ each
		Left	01.01.2016 –	4992115	_____	/ m
						/ each
	6.5	<b>Cover bar</b>	01.01.2016 –	4991910	Unit(s)	/ each
 50x	6.6	<b>Self-tapping screws M6 x 12</b>		4992181	Unit(s)	/ each
		Screws for cover			_____	
	* 6.7	<b>Complete aluminium profile guide</b>			Unit(s)	
		Right	01.01.2016 –	4992116	_____	/ m
		Left	01.01.2016 –	4992117	_____	/ each
						/ m
						/ each
	* 6.8	<b>Light grille</b>	01.01.2016 – 31.05.2021 01.06.2021 –		Unit(s)	/ each
		For article numbers and lengths see pages 176 – 178 light grille / cable concept			_____	/ each
					_____	
 6x 6x 12x 6x 6x 1x	6.9	<b>Light grille replacement accessories</b>	01.06.2021 –	4982111	Unit(s)	/ each
		From 01.06.2021 onwards, the bag is required when replacing the light grille.			_____	



\* State purchase order number

Surcharge for high-quality wet coating panel (see page 173)

EN Ceiling height

DA Distance to ceiling

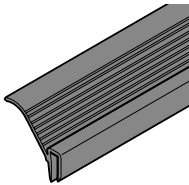
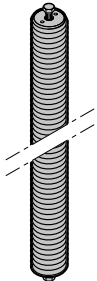
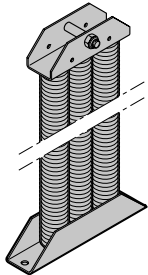
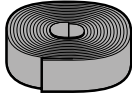
## 6. High-Speed Door HS 5015 PU N 42

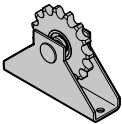
Article	Item	Description	Production period	Art. no.	Quantity	€
	*	<b>6.10 Snap cable, white, light grille</b> For article numbers and lengths see pages 176 – 178 light grille / cable concept	01.01.2016 –		Unit(s) _____	/ each
	*	<b>6.11 Seal for guide</b> Additional 2 × per side element required  4000 mm 5000 mm 6000 mm	01.01.2016 – 01.01.2016 – 01.01.2016 –	4991585 4991586 4991490	Unit(s) _____ _____ _____	/ each / each / each
	*	<b>6.12 Single spring</b>	01.01.2016 –		Unit(s) _____	/ each
	*	<b>6.13 Complete spring assembly</b>  Right Left	01.01.2016 – 01.01.2016 –		Unit(s) _____ _____	/ each / each
	*	<b>6.14 Belt</b>  3950 mm 5200 mm 7200 mm LDH + 100 mm per side serves as a calculation aid	01.01.2016 – 01.01.2016 – 01.01.2016 –	4990496 4990495 4990494	m _____ _____ _____	/ m / m / m
		<b>6.15 Roller chain reinforced</b>	01.01.2016 –	159568	m _____	/ m
		<b>6.16 Complete chain tensioner wheel</b>  Right Left	01.01.2016 – 01.01.2016 –	4990809 4990810	Unit(s) _____ _____	/ each / each



\* State purchase order number

Surcharge for high-quality wet coating panel (see page 173)

EN Ceiling height

DA Distance to ceiling

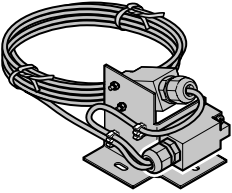
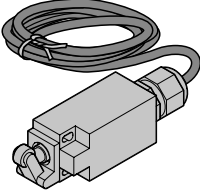
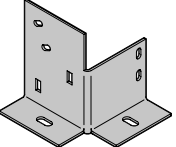
## 6. High-Speed Door HS 5015 PU N 42

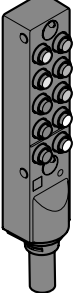
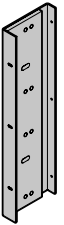
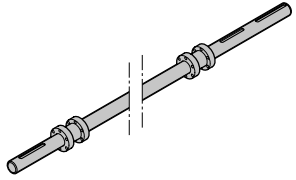
Article	Item	Description	Production period	Art. no.	Quantity	€
	<b>6.17 Button with wiring</b>	For spring and chain monitoring Right Left	01.01.2016 – 01.01.2016 –	4980327 4980337	Unit(s) _____ _____	/ each / each
	<b>6.18 Chain test button</b>	Right Left	01.01.2016 – 01.01.2016 –	4992012 4992011	Unit(s) _____ _____	/ each / each
	<b>6.19 Button support</b>	Right Left	01.01.2016 – 01.01.2016 –	4991130 4991131	Unit(s) _____ _____	/ each / each
	* <b>6.20 Snap cable blue, spring / counter weight</b>	For article numbers and lengths see pages 176 – 178 light grille / cable concept	01.01.2016 –		Unit(s) _____	/ each
	<b>6.21 Bridge plug snap 8</b>		01.01.2016 –	4980188	Unit(s) _____	/ each
	* <b>6.22 Distributor 10 x M8 snap</b>	For article numbers and lengths see pages 176 – 178 light grille / cable concept	01.01.2016 –		Unit(s) _____	/ each
	<b>6.23 Complete operator support bracket</b>		01.01.2016 –	4990800	Unit(s) _____	/ each
	* <b>6.24 Complete shaft</b>		01.01.2016 – 31.12.2018 01.01.2019 –	4992118 4981492	Unit(s) _____ _____	/ m / each / m / each





\* State purchase order number

Surcharge for high-quality wet coating panel (see page 173)

EN Ceiling height

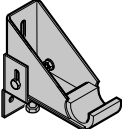

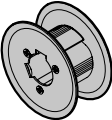
DA Distance to ceiling

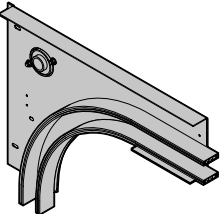
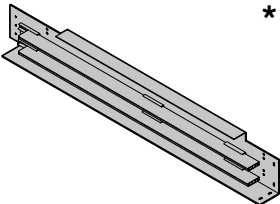
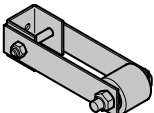
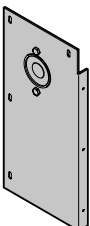
## 6. High-Speed Door HS 5015 PU N 42

Article	Item	Description	Production period	Art. no.	Quantity	€	
	6.25	Shaft support	01.01.2016 –	4990877	Unit(s) _____	/ each	
	6.26	Grooved ball-bearing ASPFL 208	01.01.2016 –	159403	Unit(s) _____	/ each	
	6.27	Chain sprocket	01.01.2016 –	4990808	Unit(s) _____	/ each	
	6.28	Guide roller Ø 70	01.01.2016 –	4981037	Unit(s) _____	/ each	
	6.29	Distance sleeve 10 mm	01.01.2016 –	4991703	Unit(s) _____	/ each	
	6.30	Adjusting ring	01.01.2016 –	159163	Unit(s) _____	/ each	
	*	6.31	Complete support curve		Unit(s)		
		Right		01.01.2016 –	4982788	_____	/ each
		Left		01.01.2016 –	4982789	_____	/ each
	*	6.32	Complete horizontal guide		Unit(s)		
		Right		01.01.2016 –	4992119	_____	/ m
		Left		01.01.2016 –	4992120	_____	/ m
	6.33	Complete return pulley	01.01.2016 –	4991214	Unit(s) _____	/ each	
	6.34	Complete cladding, bearing side			Unit(s)		
		Right		01.01.2016 – 31.12.2018	4991189	_____	/ each
		Left		01.01.2016 – 31.12.2018	4991188	_____	/ each

\* State purchase order number  
 Surcharge for high-quality wet coating panel (see page 173)  
 EN Ceiling height  
 DA Distance to ceiling

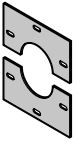
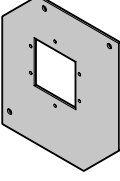
## 6. High-Speed Door HS 5015 PU N 42

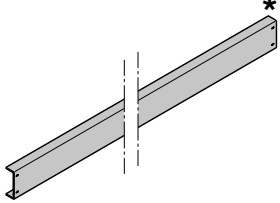
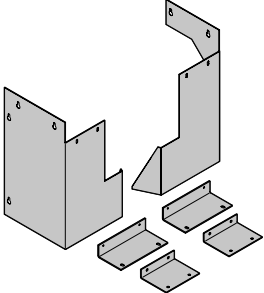
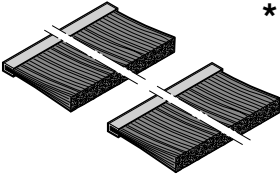
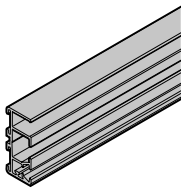
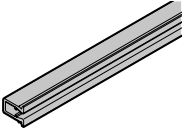
Article	Item Description	Production period	Art. no.	Quantity	€
	<b>6.35 Retaining plate for bearing</b> per door (2 units)	01.01.2019 –	4981284	Unit(s) _____	/ each
	<b>6.36 Sheet bearing</b>	01.01.2019 –	4981655	Unit(s) _____	/ each
	<b>6.37 Ball-bearing with groove</b>	01.01.2019 –	158993	Unit(s) _____	/ each
	<b>6.38 Transverse cross strut</b>	01.01.2016 –	4980914	Unit(s) _____	/ m
	<b>6.39 Cladding, complete</b>	01.01.2016 – 30.11.2018 01.12.2018 –	4991492 4981660	Unit(s) _____ _____	/ each / each
	<b>6.40 Brush seal</b>	01.01.2016 –	4982186	Unit(s) _____	/ each
	<b>6.41 Sealing frame channel</b> 4000 mm 5000 mm 6000 mm	01.01.2016 – 01.01.2016 – 01.01.2016 –	4991263 4991770 4991426	Unit(s) _____ _____ _____	/ each / each / each
	<b>6.42 Sealing frame clips</b> 4000 mm 5000 mm 6000 mm	01.01.2016 – 01.01.2016 – 01.01.2016 –	4991264 4991771 4991427	Unit(s) _____ _____ _____	/ each / each / each

\* State purchase order number

Surcharge for high-quality wet coating panel (see page 173)

EN Ceiling height

DA Distance to ceiling

## 6. High-Speed Door HS 5015 PU N 42

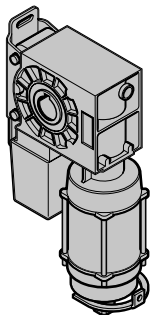
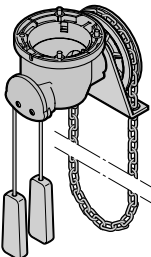
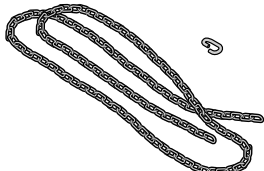
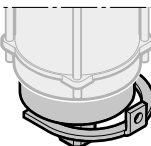
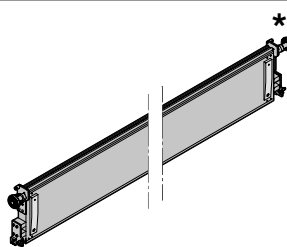
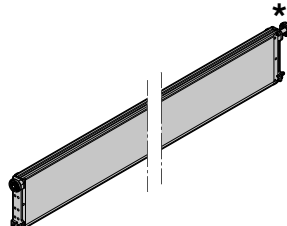
Article	Item	Description	Production period	Art. no.	Quantity	€
	*	<b>6.43 Operator</b>			Unit(s) _____	/ each
		<b>6.44 Emergency hand chain gearbox</b>	01.01.2016 –	158171	Unit(s) _____	/ each
		<b>6.45 hand chain 10 m</b> With chain link	01.01.2016 –	4982733	Unit(s) _____	/ each
		<b>6.46 Brake 11 Nm</b> <b>24 V LH U</b>	01.06.2015 –	4982120	Unit(s) _____	/ each
	*	<b>6.47 Complete top panel</b> Section height: 250 mm Standard version: RAL 9006	01.01.2016 –	4992165	Unit(s) _____	/ m / each
	*	<b>6.48 Inclination panel</b> Section height: 250 mm Standard version: RAL 9006	01.01.2016 –	4980567	Unit(s) _____	/ m / each



\* State purchase order number

Surcharge for high-quality wet coating panel (see page 173)

EN Ceiling height

DA Distance to ceiling

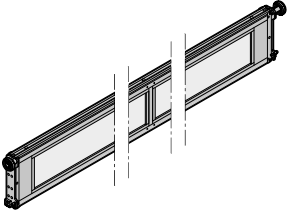
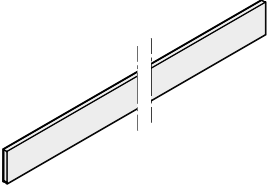
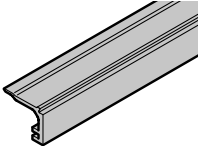
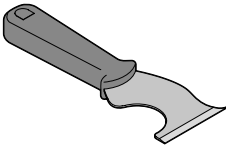
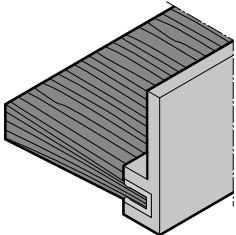
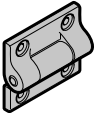
## 6. High-Speed Door HS 5015 PU N 42

Article	Item	Description	Production period	Art. no.	Quantity	€
	*	<b>6.49 Complete window profile</b>			Unit(s)	
		Double glazing	01.01.2016 –	4980565	_____	/ m
		Triple glazing	01.01.2016 –	4980565	_____	/ each / m / each
		Section height: 250 mm Standard version: RAL 9006				
	*	<b>6.50 Double pane</b>	01.01.2016 –		Unit(s)	/ each
	*	<b>6.51 Glazing bead</b>			Unit(s)	
		Short, 160.8 mm	01.01.2016 –	4992192	_____	/ each
		Long per / m	01.01.2016 –	4992194	_____	/ m
		<b>6.52 Hand scraper</b>	01.01.2016 –	4981136	Unit(s)	/ each
	*	<b>6.53 Panel lintel seal</b>	01.01.2016 –	4982187	Unit(s)	/ each
		<b>6.54 Complete centre hinge</b>			Unit(s)	
		With screws				
		black	01.01.2016 –	4991905	_____	/ each
		Silver	01.01.2016 –	4991904	_____	/ each
		<b>6.55 Roller with band</b>	01.01.2016 –	4990818	Unit(s)	/ each
		For panels				
		<b>6.56 Complete hinge connector</b>	01.01.2016 –	4981937	Unit(s)	/ each

\* State purchase order number

Surcharge for high-quality wet coating panel (see page 173)

EN Ceiling height

DA Distance to ceiling

## 6. High-Speed Door HS 5015 PU N 42

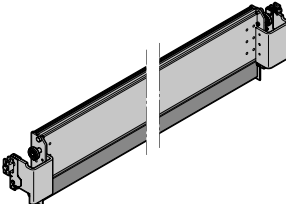
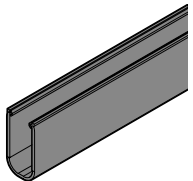
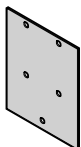
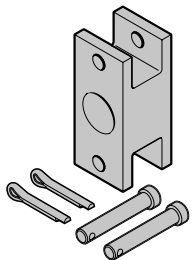
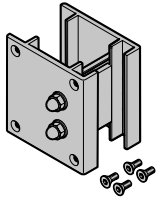
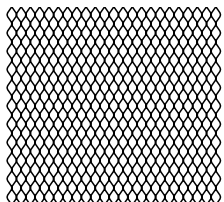
Article	Item Description	Production period	Art. no.	Quantity	€
	<b>6.57 Bottom part Complete</b>	01.01.2016 –	4992122	Unit(s) _____	/ m / each
	<b>6.58 Rubber profile</b> <b>Velcro strap</b> (additionally required: Velcro strap 1 m)	01.01.2016 – 01.03.2011 –	4980601 159601	Unit(s) _____ _____	/ m / m
	<b>6.59 UPVC canopy</b>	01.01.2016 –	4992208	Unit(s) _____	/ each
	<b>6.60 Complete chain connection</b>	01.01.2016 –	4991430	Unit(s) _____	/ each
	<b>6.61 Fixing clip</b> To hold the curtain in place when exchanging panels	01.01.2016 –	4990854	Unit(s) _____	/ each
	<b>6.62 Ventilation grille</b>	01.05.2017 –	4981282	Unit(s) _____	/ each / m.

\* State purchase order number  
 Surcharge for high-quality wet coating panel (see page 173)  
 EN Ceiling height  
 DA Distance to ceiling

# HS 5015 PU H 42

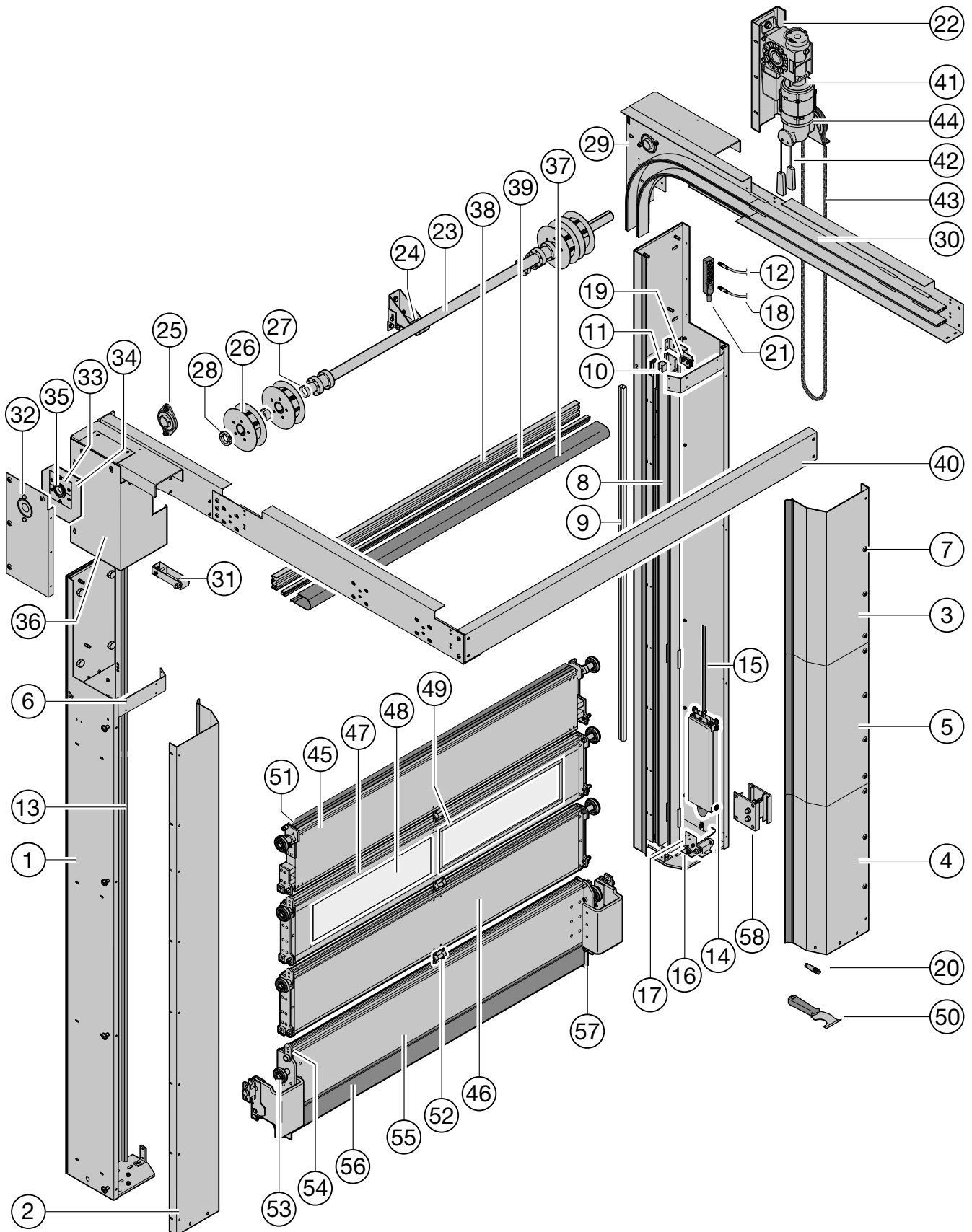

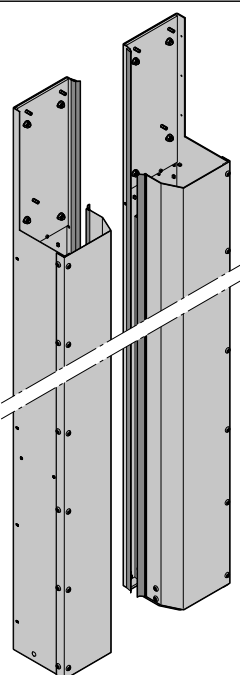
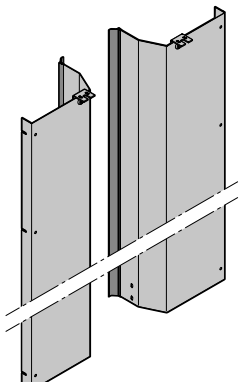
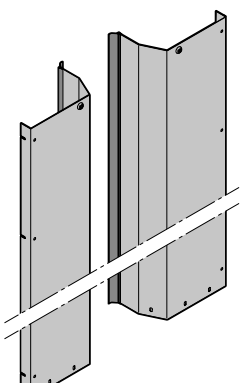

# 7. High-Speed Door HS 5015 PU H 42

Article	Item	Description	Production period	Art. no.	Quantity	€
	*	<b>7.1 Side element</b>			Unit(s)	
		DE – DA < 6245 mm				
		Right	01.01.2016 –		_____	⌚ / each
		Left	01.01.2016 –		_____	⌚ / each
	*	<b>7.2 Cover, 1-part</b>			Unit(s)	
		DE – DA ≤ 3745 mm				
		Right	01.01.2016 – 31.12.2018		_____	<b>124,00</b> / m
			01.01.2019 –		_____	<b>41,00</b> / each
	Left	01.01.2016 – 31.12.2018		_____	<b>124,00</b> / m	
			01.01.2019 –		_____	<b>41,00</b> / each
	*	<b>7.3 Top cover, 2-part</b>			Unit(s)	
		DE – DA > 3745 – ≤ 6245 mm				
		Right	01.01.2016 – 31.12.2018		_____	<b>124,00</b> / m
			01.01.2019 –		_____	<b>41,00</b> / each
	Left	01.01.2016 – 31.12.2018		_____	<b>124,00</b> / m	
			01.01.2019 –		_____	<b>41,00</b> / each

\* State purchase order number  
 Surcharge for high-quality wet coating panel (see page 173)  
 EN Ceiling height  
 DA Distance to ceiling

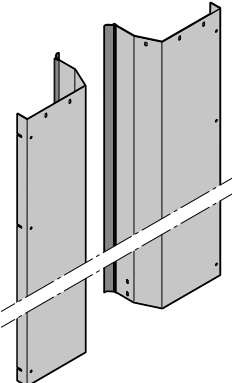
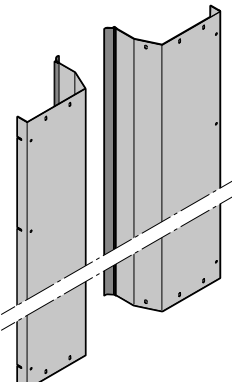
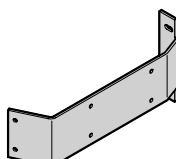
# 7. High-Speed Door HS 5015 PU H 42

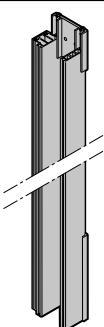
Article	Item	Description	Production period	Art. no.	Quantity	€
	* 7.4	<b>Bottom cover, 2-part</b> DE – DA > 3745 – ≤ 6245 mm Right	01.01.2016 –		Unit(s)	<b>124,00 / m</b> <b>41,00 / each</b>
		Left	01.01.2016 –			<b>124,00 / m</b> <b>41,00 / each</b>
	* 7.5	<b>Centre cover, 3-part</b> DE – DA > 6245 mm Right	01.01.2016 –		Unit(s)	<b>124,00 / m</b> <b>41,00 / each</b>
		Left	01.01.2016 –			<b>124,00 / m</b> <b>41,00 / each</b>
	7.6	<b>Cover bar</b>	01.01.2016 –		Unit(s)	<b>24,00 / each</b>
 50x	7.7	<b>Self-tapping screws M6 x 12</b> Screws for cover			Unit(s)	<b>15,60 / each</b>
	* 7.8	<b>Complete aluminium profile guide</b> Right	01.01.2016 –		Unit(s)	<b>112,00 / m</b> <b>105,00 / each</b>
		Left	01.01.2016 –			<b>112,00 / m</b> <b>105,00 / each</b>



\* State purchase order number

Surcharge for high-quality wet coating panel (see page 173)

EN Ceiling height

DA Distance to ceiling

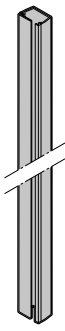
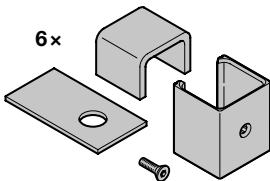
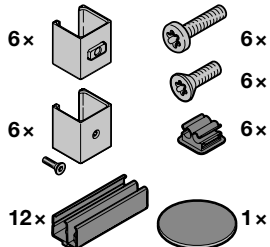
## 7. High-Speed Door HS 5015 PU H 42

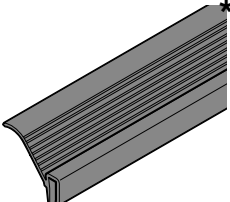
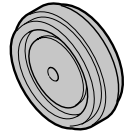
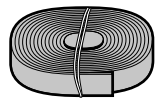
Article	Item	Description	Production period	Art. no.	Quantity	€
	*	<b>7.9 Light grille</b> For article numbers and lengths see pages 176 – 178 light grille / cable concept	01.01.2016 – 31.05.2021 01.06.2021 –		Unit(s) _____ _____ _____	<b>1498,00 /each</b> <b>1114,00 /each</b>
	6x	<b>7.10 Holder for light grille</b>	01.01.2017 – 31.05.2021		Unit(s) _____	<b>19,30 /each</b>
	6x 6x 12x 6x 6x 1x	<b>7.11 Light grille replacement accessories</b> From 01.06.2021 onwards, the bag is required when replacing the light grille.	01.06.2021 –		Unit(s) _____	<b>18,30 /each</b>
	*	<b>7.12 Snap cable, white, light grille</b> For article numbers and lengths see pages 176 – 178 light grille / cable concept	01.01.2016 –		Unit(s) _____	<b>36,00 /each</b>
	*	<b>7.13 Seal for guide</b> Additional 2 x per side element required  4000 mm 5000 mm 6000 mm	01.01.2016 – 01.01.2016 – 01.01.2016 –		Unit(s) _____ _____ _____	<b>70,00 /each</b> <b>70,00 /each</b> <b>70,00 /each</b>
		<b>7.14 Roller</b> For the counter weight	01.01.2016 –		Unit(s) _____	<b>28,00 /each</b>
		<b>7.15 Flat belt 30 mm</b> For curtain and weight	01.01.2016 –		Unit(s) _____	<b>45,00 / m</b>





\* State purchase order number

Surcharge for high-quality wet coating panel (see page 173)

EN Ceiling height

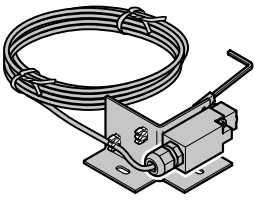
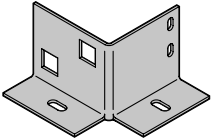
DA Distance to ceiling

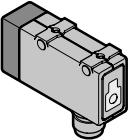
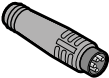
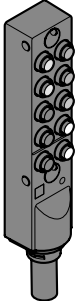
## 7. High-Speed Door HS 5015 PU H 42

Article	Item	Description	Production period	Art. no.	Quantity	€
	<b>7.16 Counter weight button with wiring snapM8</b>				Unit(s)	
	Right Left		01.01.2016 – 01.01.2016 –		_____ _____	<b>110,00 / each</b> <b>110,00 / each</b>
	<b>7.17 Button support</b>				Unit(s)	
	Right Left		01.01.2016 – 01.01.2016 –		_____ _____	<b>17,60 / each</b> <b>17,60 / each</b>
	* <b>7.18 Snap cable</b>				Unit(s)	
	blue, spring / counter weight yellow, belt monitoring For article numbers and lengths see pages 176 – 178 light grille / cable concept		01.01.2016 – 01.01.2016 –		_____ _____	<b>37,00 / each</b> <b>37,00 / each</b>
	<b>7.19 Light button reflection</b>				Unit(s)	
	Discontinued articles The support bracket of the existing switch is not compatible with the new switch. You need the new support bracket to replace the switch (7992043, €8.40). For curtain belt monitoring		01.01.2016 – 31.10.2024  01.11.2024 –		_____ _____	<b>147,00 / each</b> <b>158,00 / each</b>
	<b>7.20 Bridge plug snap 8</b>				Unit(s)	
			01.01.2016 –		_____	<b>16,40 / each</b>
	* <b>7.21 Distributor 10 x M8 snap</b>				Unit(s)	
	For article numbers and lengths see pages 176 – 178 light grille / cable concept		01.01.2016 –		_____	<b>241,00 / each</b>
	<b>7.22 Complete operator support bracket</b>				Unit(s)	
			01.01.2016 –		_____	<b>198,00 / each</b>



\* State purchase order number

Surcharge for high-quality wet coating panel (see page 173)

EN Ceiling height

DA Distance to ceiling

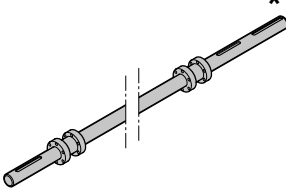
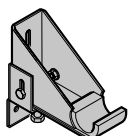
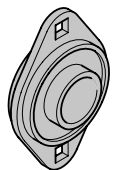
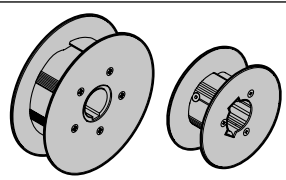
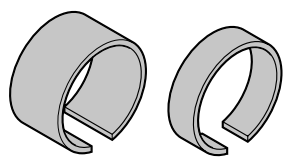
## 7. High-Speed Door HS 5015 PU H 42

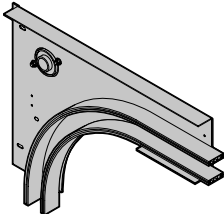
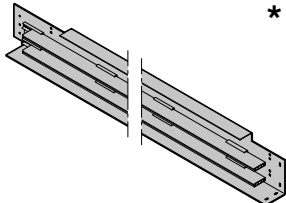
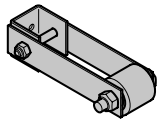
Article	Item	Description	Production period	Art. no.	Quantity	€
	<b>7.23</b>	<b>Complete shaft</b>	01.01.2016 – 30.11.2018 01.12.2018 –		Unit(s) _____ _____	<b>77,00 / m</b> <b>515,00 / each</b> <b>77,00 / m</b> <b>515,00 / each</b>
	<b>7.24</b>	<b>Shaft support</b>	01.01.2016 –		Unit(s) _____	<b>99,00 / each</b>
	<b>7.25</b>	<b>Grooved ball-bearing ASPFL 208</b>	01.01.2016 –		Unit(s) _____	<b>89,00 / each</b>
	<b>7.26</b>	<b>Pulley</b> Ø 145 Ø 70	01.01.2016 – 01.01.2016 –		Unit(s) _____ _____	<b>93,00 / each</b> <b>70,00 / each</b>
	<b>7.27</b>	<b>distance sleeve</b> 27 mm 30 mm 14 mm 12 mm	01.01.2016 – 30.11.2018 01.12.2018 – 01.01.2016 – 30.11.2018 01.12.2018 –		Unit(s) _____ _____ _____ _____	<b>9,30 / each</b> <b>9,60 / each</b> <b>8,70 / each</b> <b>7,60 / each</b>
	<b>7.28</b>	<b>Adjusting ring</b>	01.01.2016 –		Unit(s) _____	<b>30,00 / each</b>
	<b>7.29</b>	<b>Complete support curve</b> Right Left	01.01.2016 – 01.01.2016 –		Unit(s) _____ _____	<b>1008,00 / each</b> <b>1008,00 / each</b>
	<b>7.30</b>	<b>Complete horizontal guide</b> Right Left	01.01.2016 – 01.01.2016 –		Unit(s) _____ _____	<b>194,00 / m</b> <b>194,00 / m</b>
	<b>7.31</b>	<b>Complete return pulley</b>	01.01.2016 –		Unit(s) _____	<b>41,00 / each</b>



\* State purchase order number

Surcharge for high-quality wet coating panel (see page 173)

EN Ceiling height

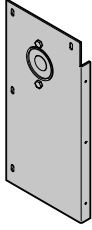
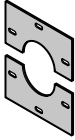
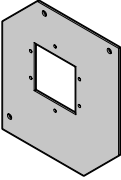

DA Distance to ceiling

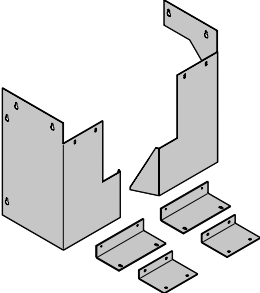
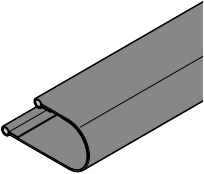
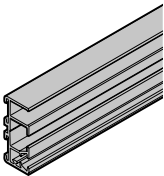
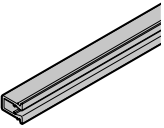
## 7. High-Speed Door HS 5015 PU H 42

Article	Item	Description	Production period	Art. no.	Quantity	€
	<b>7.32</b>	<b>Complete cladding, bearing side</b> Right Left	01.01.2016 – 30.11.2018 01.01.2016 – 30.11.2018		Unit(s) _____ _____	<b>95,00 / each</b> <b>95,00 / each</b>
	<b>7.33</b>	<b>Retaining plate for bearing</b> per door (2 units)	01.12.2018 –		Unit(s) _____	<b>3,60 / each</b>
	<b>7.34</b>	<b>Sheet bearing</b>	01.12.2018 –		Unit(s) _____	<b>20,10 / each</b>
	<b>7.35</b>	<b>Ball-bearing with groove</b>	01.12.2018 –		Unit(s) _____	<b>8,70 / each</b>
	<b>7.36</b>	<b>Cladding, complete</b>	01.01.2016 – 30.11.2018 01.12.2018 –		Unit(s) _____ _____	<b>68,00 / each</b> <b>68,00 / each</b>
	<b>* 7.37</b>	<b>Curtain loop complete</b> 80, without ThermoFrame 100, with ThermoFrame	01.01.2016 – 01.01.2016 –		Unit(s) _____ _____	<b>24,00 / m</b> <b>24,00 / m</b>
	<b>* 7.38</b>	<b>Sealing frame channel</b> 4000 mm 5000 mm 6000 mm	01.01.2016 – 01.01.2016 – 01.01.2016 –		Unit(s) _____ _____ _____	<b>81,00 / each</b> <b>81,00 / each</b> <b>81,00 / each</b>
	<b>* 7.39</b>	<b>Sealing frame clips</b> 4000 mm 5000 mm 6000 mm	01.01.2016 – 01.01.2016 – 01.01.2016 –		Unit(s) _____ _____ _____	<b>33,00 / each</b> <b>33,00 / each</b> <b>33,00 / each</b>

\* State purchase order number  
 Surcharge for high-quality wet coating panel (see page 173)  
 EN Ceiling height  
 DA Distance to ceiling

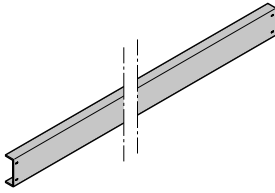
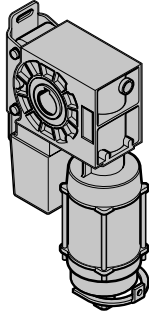
## 7. High-Speed Door HS 5015 PU H 42

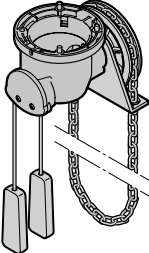
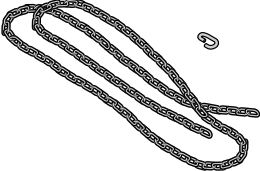
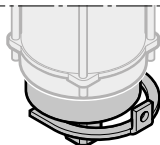
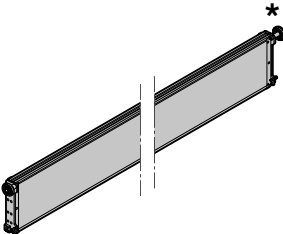
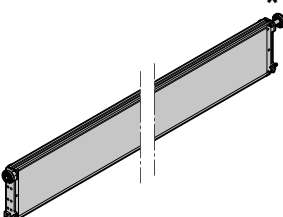
Article	Item	Description	Production period	Art. no.	Quantity	€
	*	<b>7.40 Transverse cross strut</b>	01.01.2016 –		Unit(s) _____	<b>66,00 / m</b>
	*	<b>7.41 Operator</b>			Unit(s) _____	 / each
		<b>7.42 Emergency hand chain gearbox</b>	01.01.2016 –		Unit(s) _____	<b>650,00 / each</b>
		<b>7.43 hand chain 10 m</b> With chain link	01.01.2016 –		Unit(s) _____	<b>52,00 / each</b>
		<b>7.44 Brake 11 Nm</b> <b>24 V LH U</b>	01.01.2016 –		Unit(s) _____	<b>954,00 / each</b>
	*	<b>7.45 Complete top panel</b> Section height: 250 mm Standard version: RAL 9006	01.01.2016 –		Unit(s) _____	<b>104,00 / m</b> <b>143,00 / each</b>
	*	<b>7.46 Inclination panel</b> Section height: 250 mm Standard version: RAL 9006	01.01.2016 –		Unit(s) _____	<b>104,00 / m</b> <b>143,00 / each</b>

\* State purchase order number  
Surcharge for high-quality wet coating panel (see page 173)

EN Ceiling height

DA Distance to ceiling

# 7. High-Speed Door HS 5015 PU H 42

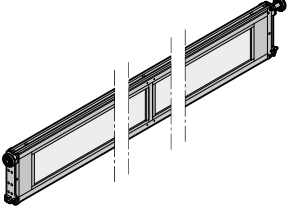
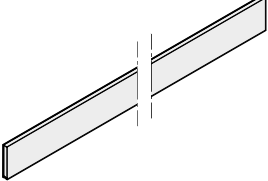
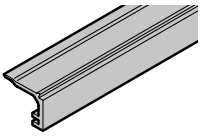
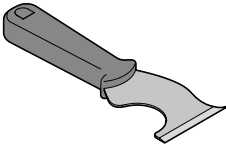
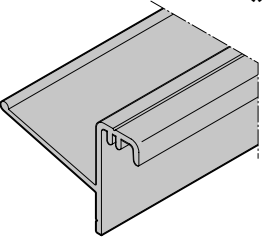
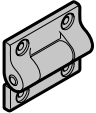
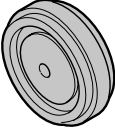
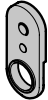
Article	Item	Description	Production period	Art. no.	Quantity	€
	* <b>7.47 Complete window profile</b>	Double glazing Triple glazing Section height: 250 mm Standard version: RAL 9006	01.01.2016 – 01.01.2016 –		Unit(s) _____ _____ _____	<b>155,00 / m</b> <b>256,00 / each</b> <b>199,00 / m</b> <b>333,00 / each</b>
	* <b>7.48 Double pane</b>		01.01.2016 –		Unit(s) _____	<b>146,00 / each</b>
	* <b>7.49 Glazing bead</b>	Short, 160.8 mm Long per / m	01.01.2016 – 01.01.2016 –		Unit(s) _____ _____	<b>4,90 / each</b> <b>4,90 / m</b>
	<b>7.50 Hand scraper</b>		01.01.2016 –		Unit(s) _____	<b>82,00 / each</b>
	* <b>7.51 Panel lintel seal</b>		01.01.2016 –		Unit(s) _____	<b>80,00 / each</b>
	<b>7.52 Complete centre hinge</b>	With screws black Silver	01.01.2016 – 01.01.2016 –		Unit(s) _____ _____	<b>7,60 / each</b> <b>6,80 / each</b>
	<b>7.53 Roller with band</b>	For panels	01.01.2016 –		Unit(s) _____	<b>6,80 / each</b>
	<b>7.54 Complete hinge connector</b>		01.01.2016 –		Unit(s) _____	<b>9,90 / each</b>

\* State purchase order number  
 Surcharge for high-quality wet coating panel (see page 173)  
 EN Ceiling height  
 DA Distance to ceiling

## 7. High-Speed Door HS 5015 PU H 42

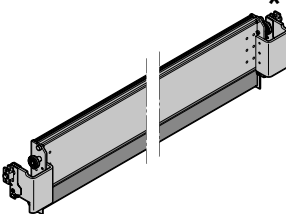
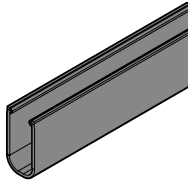
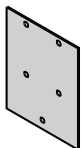
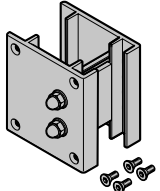
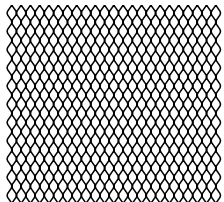
Article	Item Description	Production period	Art. no.	Quantity	€
	<b>7.55 Bottom part Complete</b>	01.01.2016 –		Unit(s) _____	<b>127,00 / m</b> <b>554,00 / each</b>
	<b>7.56 Rubber profile Velcro strap</b> (additionally required: Velcro strap 1 m)	01.01.2016 – 01.03.2011 –		Unit(s) _____ _____	<b>63,00 / m</b> <b>9,30 / m</b>
	<b>7.57 UPVC canopy</b>	01.01.2016 –		Unit(s) _____	<b>5,40 / each</b>
	<b>7.58 Fixing clip</b> To hold the curtain in place when exchanging panels	01.01.2016 –		Unit(s) _____	<b>50,00 / each</b>
	<b>7.59 Ventilation grille</b>	01.05.2017 –		Unit(s) _____	<b>104,00 / m.</b> <b>143,00 / each</b>

\* State purchase order number  
Surcharge for high-quality wet coating panel (see page 173)

EN Ceiling height

DA Distance to ceiling

# HS 6015 PU V 42

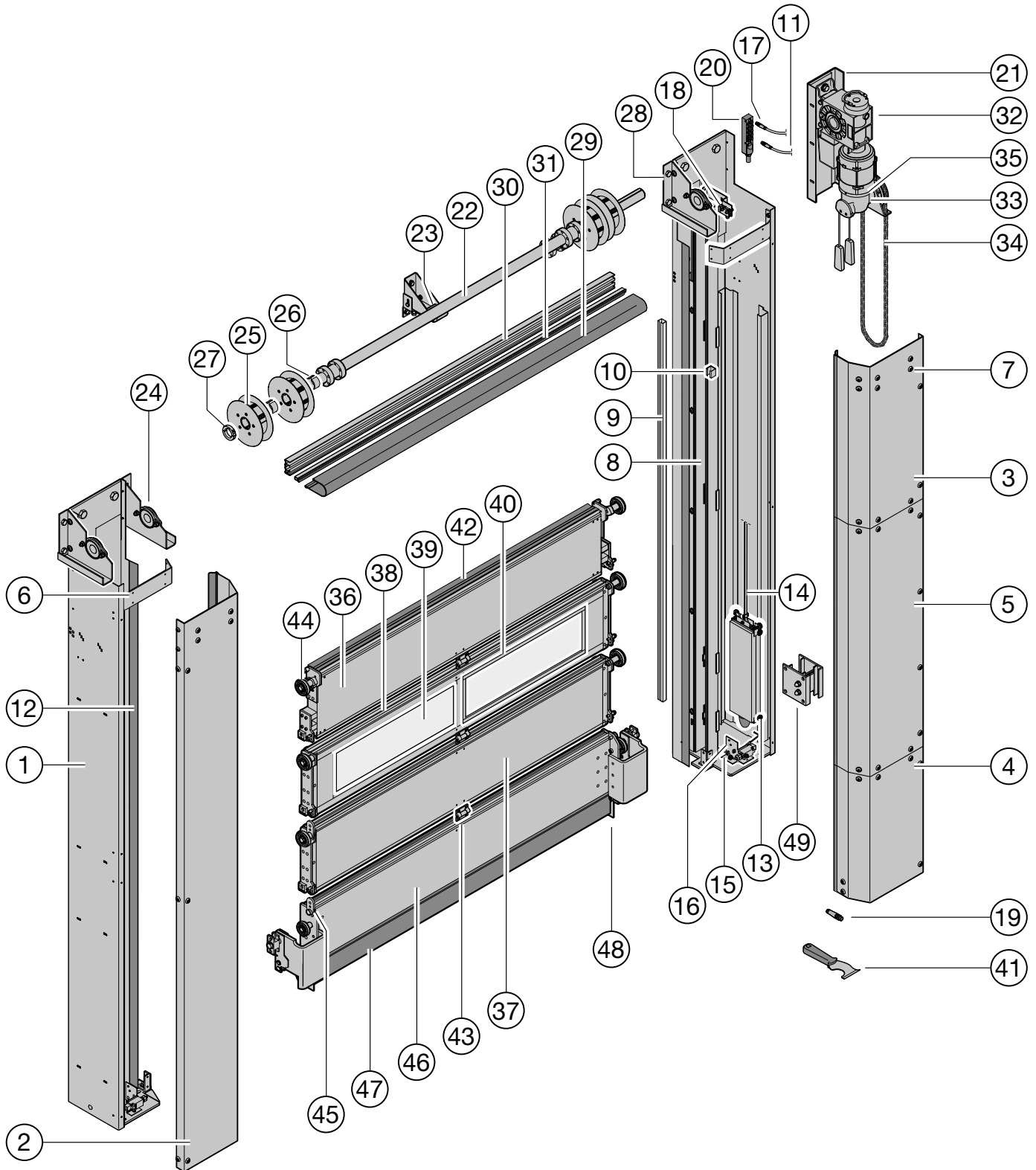

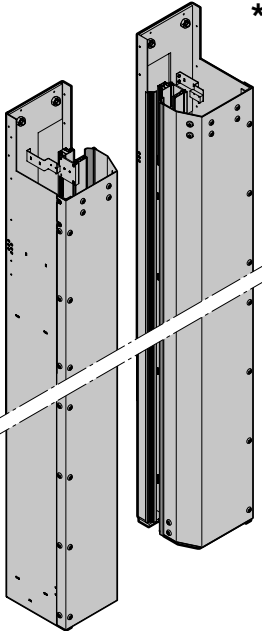
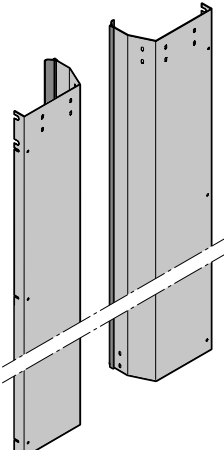
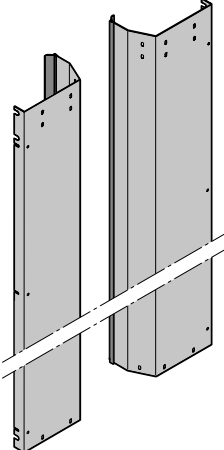

## 8. High-Speed Door HS 6015 PU V 42

Article	Item	Description	Production period	Art. no.	Quantity	€
	*	<b>8.1 Side element</b>			Unit(s)	
		Right	01.01.2016 –	4992123	_____	/ each
		Left	01.01.2016 –	4992124	_____	/ each
	*	<b>8.2 Cover, 1-part</b>			Unit(s)	
		LDH ≤ 2000 mm Right	01.01.2016 –	4992125	_____	/ m / each
		Left	01.01.2016 –	4992126	_____	/ m / each
	*	<b>8.3 Top cover, 2-part</b>			Unit(s)	
		LDH ≤ 3000 mm Right	01.01.2016 –	4992127	_____	/ m / each
		Left	01.01.2016 –	4992129	_____	/ m / each



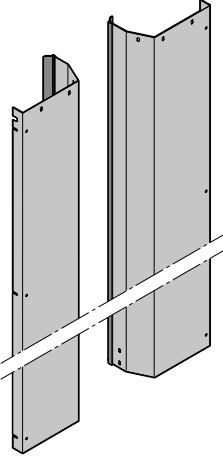
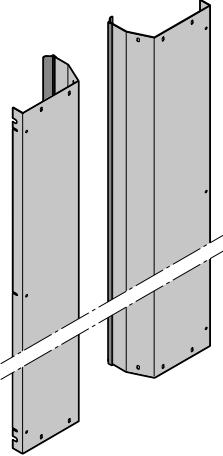
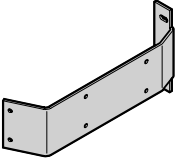

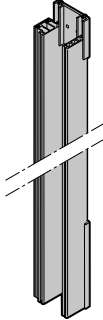
\* State purchase order number  
Surcharge for high-quality wet coating panel (see page 173)

## 8. High-Speed Door HS 6015 PU V 42

Article	Item	Description	Production period	Art. no.	Quantity	€
	*	<b>8.4 Bottom cover, 2-part</b>			Unit(s)	
		LDH ≤ 3000 mm Right	01.01.2016 –	4992128	_____	/ m / each
		Left	01.01.2016 –	4992130	_____	/ m / each
	*	<b>8.5 Centre cover, 3-part</b>			Unit(s)	
		LDH > 3000 mm Right	01.01.2016 –	4992131	_____	/ m / each
		Left	01.01.2016 –	4992132	_____	/ m / each
		<b>8.6 Cover bar</b>	01.01.2016 –	4991910	_____	/ each
		<b>8.7 Self-tapping screws M6 x 12</b> Screws for cover		4992181	_____	/ each
	*	<b>8.8 Complete aluminium profile guide</b>			Unit(s)	
		Right	01.01.2016 –	4992133	_____	/ m / each
		Left	01.01.2016 –	4992134	_____	/ m / each

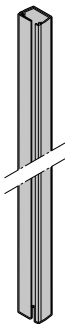
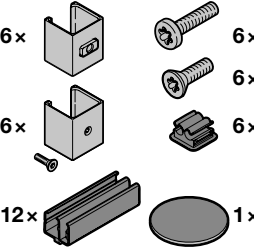

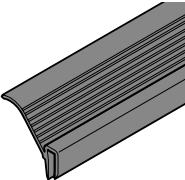

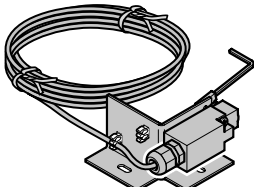

\* State purchase order number  
Surcharge for high-quality wet coating panel (see page 173)

## 8. High-Speed Door HS 6015 PU V 42

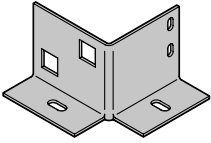
Article	Item	Description	Production period	Art. no.	Quantity	€
	*	<b>8.9 Light grille</b>  For article numbers and lengths see pages 176 – 178 light grille / cable concept	01.01.2016 – 31.05.2021 01.06.2021 –		Unit(s) _____ _____	/ each  / each
		<b>8.10 Light grille replacement accessories</b>  From 01.06.2021 onwards, the bag is required when replacing the light grille.	01.06.2021 –	4982111	Unit(s) _____	/ each
	*	<b>8.11 Snap cable, white, light grille</b>  For article numbers and lengths see pages 176 – 178 light grille / cable concept	01.01.2016 –		Unit(s) _____	/ each
	*	<b>8.12 Seal for guide</b>  Additional 2 x per side element required  4000 mm 5000 mm 6000 mm	01.01.2016 – 01.01.2016 – 01.01.2016 –	4991585 4991586 4991490	Unit(s) _____ _____ _____	/ each  / each  / each
		<b>8.13 Roller</b>  For the counter weight	01.01.2016 –	159413	Unit(s) _____	/ each
		<b>8.14 Flat belt 30 mm</b>  For curtain and weight 2x LDH + 1200 mm serves as a calculation aid	01.01.2016 –	4991432	Unit(s) _____	/ m
		<b>8.15 Counter weight button with wiring snapM8</b>  Right Left	01.01.2016 – 01.01.2016 –	4981665 4981666	Unit(s) _____ _____	/ each  / each

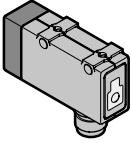
\* State purchase order number  
Surcharge for high-quality wet coating panel (see page 173)

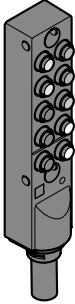
## 8. High-Speed Door HS 6015 PU V 42

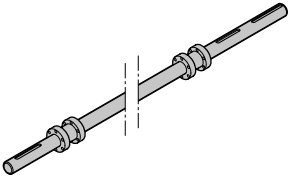
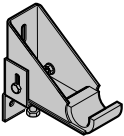
Article	Item	Description	Production period	Art. no.	Quantity	€
	<b>8.16 Button support</b>				Unit(s)	
	Right		01.01.2016 –	4981585	_____	/ each
	Left		01.01.2016 –	4981586	_____	/ each
	* <b>8.17 Snap cable</b>				Unit(s)	
	blue, spring / counter weight		01.01.2016 –		_____	/ each
	yellow, belt monitoring		01.01.2016 –		_____	/ each
	<b>8.18 Light button reflection</b>				Unit(s)	
	Discontinued articles		01.01.2016 – 31.10.2024	4991409	_____	/ each
	The support bracket of the existing switch is not compatible with the new switch. You need the new support bracket to replace the switch (7992042, €9.60).		01.11.2024 –	4982897	_____	/ each
	<b>8.19 Bridge plug snap8</b>		01.01.2016 –	4980188	Unit(s) _____	/ each
	* <b>8.20 Distributor 10 x M8 snap</b>				Unit(s)	
	For article numbers and lengths see pages 176 – 178 light grille / cable concept		01.01.2016 –		_____	/ each
	<b>8.21 Complete operator support bracket</b>		01.01.2016 –	4990800	Unit(s) _____	/ each
	* <b>8.22 Complete shaft</b>				Unit(s)	
			01.01.2016 – 30.11.2018	4992135	_____	/ m / each
			01.12.2018 –	4981489	_____	/ m / each
	<b>8.23 Shaft support</b>		01.01.2016 –	4990877	Unit(s) _____	/ each

\* State purchase order number  
Surcharge for high-quality wet coating panel (see page 173)

## 8. High-Speed Door HS 6015 PU V 42

Article	Item	Description	Production period	Art. no.	Quantity	€
	<b>8.24</b>	<b>Grooved ball-bearing ASPFL 208</b>	01.01.2016 –	159403	Unit(s) _____	/ each
	<b>8.25</b>	<b>Pulley Ø 145</b>	01.01.2016 –	4991433	Unit(s) _____	/ each
	<b>8.26</b>	<b>distance sleeve</b>  27 mm 30 mm 12 mm	01.01.2016 – 30.11.2018 01.12.2018 – 01.12.2018 –	4991434 4991805 4981667	Unit(s) _____ _____ _____	/ each / each / each
	<b>8.27</b>	<b>Adjusting ring</b>	01.01.2016 –	159163	Unit(s) _____	/ each
	<b>8.28</b>	<b>Complete bearing support</b>  Right Left	01.01.2016 – 01.01.2016 –	4991425 4991424	Unit(s) _____ _____	/ each / each
	<b>* 8.29</b>	<b>Curtain loop complete</b>  80, without ThermoFrame 100, with ThermoFrame	01.01.2016 – 01.01.2016 –	4991415 4991342	Unit(s) _____ _____	/ m / m
	<b>* 8.30</b>	<b>Sealing frame channel</b>  4000 mm 5000 mm 6000 mm	01.01.2016 – 01.01.2016 – 01.01.2016 –	4991263 4991770 4991426	Unit(s) _____ _____ _____	/ each / each / each
	<b>* 8.31</b>	<b>Sealing frame clips</b>  4000 mm 5000 mm 6000 mm	01.01.2016 – 01.01.2016 – 01.01.2016 –	4991264 4991771 4991427	Unit(s) _____ _____ _____	/ each / each / each

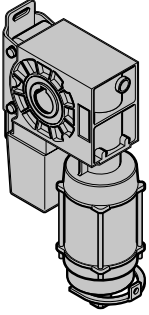
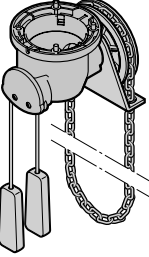
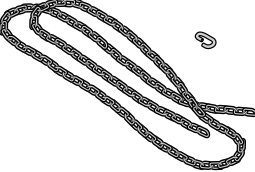
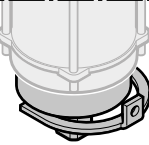
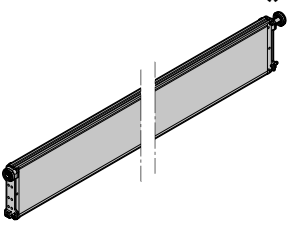
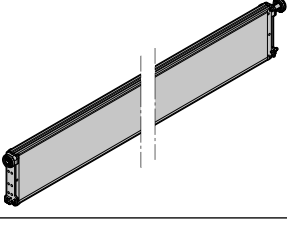
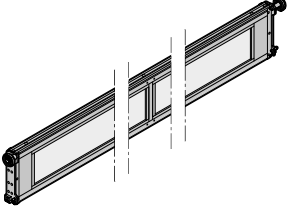

\* State purchase order number  
Surcharge for high-quality wet coating panel (see page 173)

## 8. High-Speed Door HS 6015 PU V 42

Article	Item	Description	Production period	Art. no.	Quantity	€
	*	<b>8.32 Operator</b>			Unit(s) _____	/ each
		<b>8.33 Emergency hand chain gearbox</b>	01.01.2016 –	158171	Unit(s) _____	/ each
		<b>8.34 hand chain 10 m</b> With chain link	01.01.2016 –	4982733	Unit(s) _____	/ each
		<b>8.35 Brake 11 Nm</b> <b>24 V LH U</b>	01.01.2015 –	4982120	Unit(s) _____	/ each
	*	<b>8.36 Complete top panel</b> Section height: 250 mm Standard version: RAL 9006	01.01.2016 –	4992180	Unit(s) _____	/ m / each
	*	<b>8.37 Inclination panel</b> Section height: 250 mm Standard version: RAL 9006	01.01.2016 –	4980567	Unit(s) _____	/ m / each
	*	<b>8.38 Complete window profile</b> Double glazing Triple glazing Section height: 250 mm Standard version: RAL 9006	01.01.2016 – 01.01.2016 –	4980565 4980565	Unit(s) _____ _____	/ m / each / m / each

\* State purchase order number  
Surcharge for high-quality wet coating panel (see page 173)

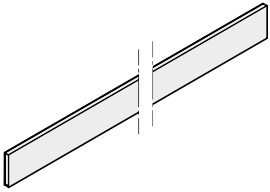
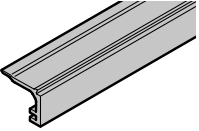
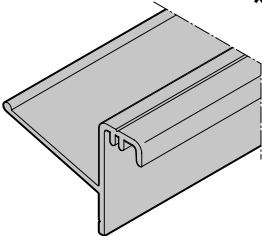
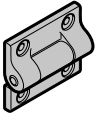
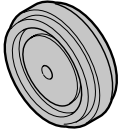
## 8. High-Speed Door HS 6015 PU V 42

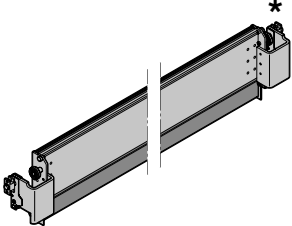
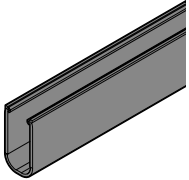
Article	Item	Description	Production period	Art. no.	Quantity	€
	*	<b>8.39 Double pane</b>	01.01.2016 –		Unit(s) _____	/ each
	*	<b>8.40 Glazing bead</b> Short, 160.8 mm long, per / m	01.01.2016 – 01.01.2016 –	4992192 4992194	Unit(s) _____ _____	/ each / m
		<b>8.41 Hand scraper</b>	01.01.2016 –	4981136	Unit(s) _____	/ each
	*	<b>8.42 Panel lintel seal</b>	01.01.2016 –	4991922	Unit(s) _____	/ each
		<b>8.43 Complete centre hinge</b> With screws  black Silver	01.01.2016 – 01.01.2016 –	4991905 4991904	Unit(s) _____ _____	/ each / each
		<b>8.44 Roller with band</b> For panels	01.01.2016 –	4990818	Unit(s) _____	/ each
		<b>8.45 Complete hinge connector</b>	01.01.2016 –	4981937	Unit(s) _____	/ each
	*	<b>8.46 Bottom part Complete</b>	01.01.2016 –	4992166	Unit(s) _____	/ m / each
	*	<b>8.47 Rubber profile Velcro strap</b> (additionally required: Velcro strap 1 m)	01.01.2016 – 01.03.2011 –	4980601 159601	Unit(s) _____ _____	/ m / m

\* State purchase order number  
Surcharge for high-quality wet coating panel (see page 173)

## 8. High-Speed Door HS 6015 PU V 42

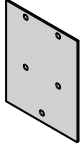
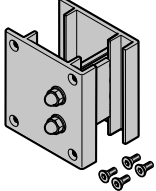
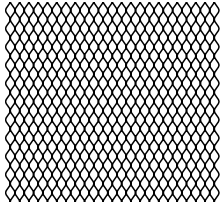
Article	Item Description	Production period	Art. no.	Quantity	€
	<b>8.48 UPVC canopy</b>	01.01.2016 –	4992208	Unit(s) _____	/ each
	<b>8.49 Fixing clip</b> To hold the curtain in place when exchanging panels	01.01.2016 –	4990854	Unit(s) _____	/ each
	<b>8.50 Ventilation grille</b>	01.05.2017 –	4981282	Unit(s) _____	/ m. / each

\* State purchase order number  
Surcharge for high-quality wet coating panel (see page 173)

# HS 5012 PU 42 S

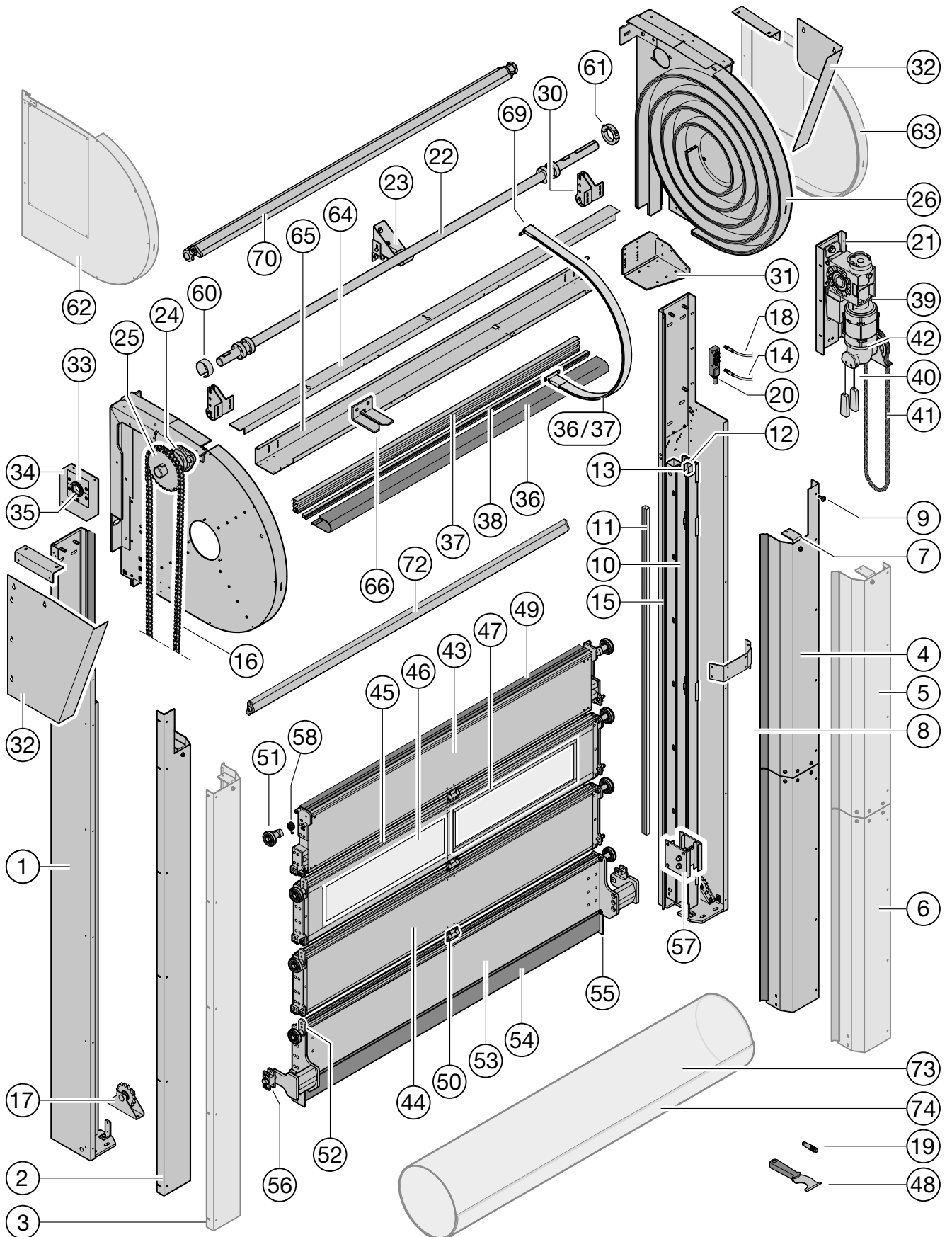

# 9. High-Speed Door HS 5012 PU 42 S

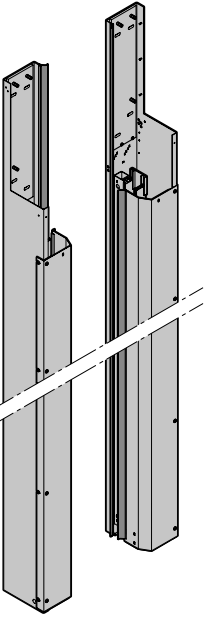
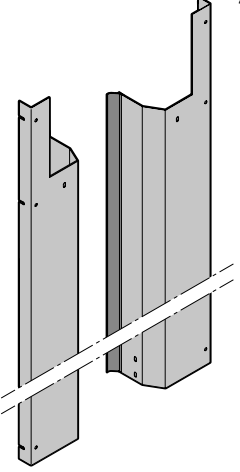
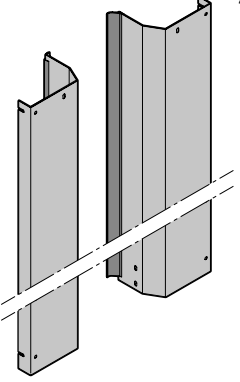
Article	Item	Description	Production period	Art. no.	Quantity	€
	*	<b>9.1 Side element</b>			Unit(s)	
		Right	01.03.2019 –	4981611	_____	/ each
		Left	01.03.2019 –	4981612	_____	/ each
	*	<b>9.2 Cover, 1-part</b>			Unit(s)	
		LDH ≤ 3250 mm, without cladding				
		Right	01.03.2019 –	4981613	_____	/ m
		Left	01.03.2019 –	4981615	_____	/ m
	*	<b>9.3 Cover, 1-part</b>			Unit(s)	
		LDH ≤ 3250 mm, with cladding				
		Right	01.03.2019 –	4981614	_____	/ m
		Left	01.03.2019 –	4981616	_____	/ m



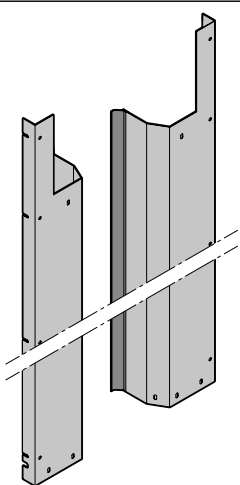
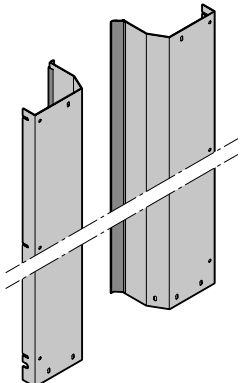
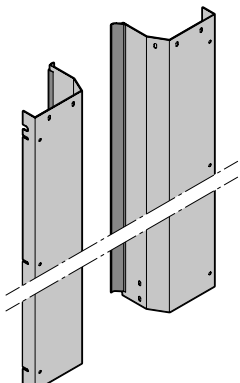
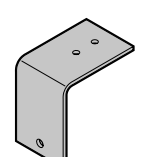
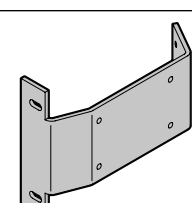

\* State purchase order number  
 Surcharge for high-quality wet coating panel (see page 173)

# 9. High-Speed Door HS 5012 PU 42 S

Article	Item	Description	Production period	Art. no.	Quantity	€
	*	<b>9.4 Top cover, 2-part</b>			Unit(s)	
		LDH > 3250 mm, without cladding Right	01.03.2019 –	4981618	_____	/ m
		Left	01.03.2019 –	4981621	_____	/ each / m / each
	*	<b>9.5 Top cover, 2-part</b>			Unit(s)	
		LDH > 3250 mm, with cladding Right	01.03.2019 –	4981619	_____	/ m
		Left	01.03.2019 –	4981622	_____	/ each / m / each
	*	<b>9.6 Bottom cover, 2-part</b>			Unit(s)	
		LDH > 3250 mm, without cladding Right	01.03.2019 –	4981617	_____	/ m
		Left	01.03.2019 –	4981620	_____	/ each / m / each
		<b>9.7 Cover support bracket</b>			Unit(s)	
		3-sided without cladding	01.03.2019 –	4981623	_____	/ each
		2-sided with cladding	01.03.2019 – 01.06.2025 –	4981624 7992909	_____ _____	/ each / each
		<b>9.8 Cover bar</b>	01.03.2019 –	4981625	Unit(s) _____	/ each

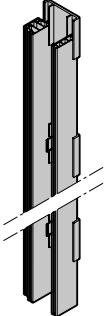

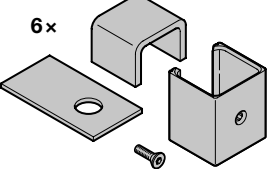
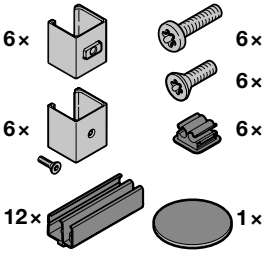

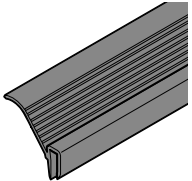
\* State purchase order number  
Surcharge for high-quality wet coating panel (see page 173)

# 9. High-Speed Door HS 5012 PU 42 S

Article	Item	Description	Production period	Art. no.	Quantity	€
	50x	<b>9.9 Self-tapping screws M6 x 12</b> Screws for cover		4992181	Unit(s) _____	/ each
	*	<b>9.10 Complete aluminium profile guide</b>  Right  Left	01.03.2019 –  01.03.2019 –	4981626  4981627	Unit(s) _____  _____	/ m / each / m / each
	*	<b>9.11 Light grille</b>  For article numbers and lengths see pages 176 – 178 light grille / cable concept	01.03.2019 – 31.05.2021 01.06.2021 –		Unit(s) _____  _____	/ each / each
	6x	<b>9.12 Holder for light grille</b>	01.01.2017 – 31.05.2021	4981440	Unit(s) _____	/ each
	6x 6x 6x 12x 6x 6x 1x	<b>9.13 Light grille replacement accessories</b> From 01.06.2021 onwards, the bag is required when replacing the light grille.	01.06.2021 –	4982111	Unit(s) _____	/ each
	*	<b>9.14 Snap cable, white, light grille</b> For article numbers and lengths see pages 176 – 178 light grille / cable concept	01.03.2019 –		Unit(s) _____	/ each
	*	<b>9.15 Seal for guide</b> Additional 2 x per side element required  4000 mm 5000 mm 6000 mm	01.01.2016 – 01.01.2016 – 01.01.2016 –	4991585 4991586 4991490	Unit(s) _____  _____  _____	/ each / each / each

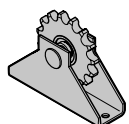
\* State purchase order number  
Surcharge for high-quality wet coating panel (see page 173)

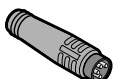
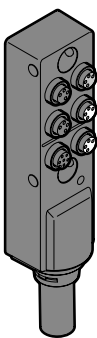
## 9. High-Speed Door HS 5012 PU 42 S

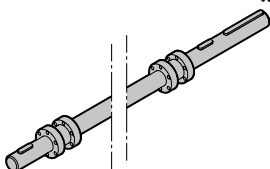
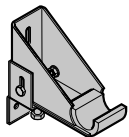
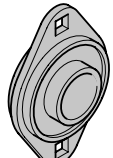
Article	Item	Description	Production period	Art. no.	Quantity	€
	*	<b>9.16 Roller chain reinforced</b>	01.03.2019 –	159568	Unit(s) _____	/ m
		<b>9.17 Complete chain tensioner wheel</b>			Unit(s) _____	
		Right	01.03.2019 –	4990809	_____	/ each
		Left	01.03.2019 –	4990810	_____	/ each
	*	<b>9.18 Snap cable blue, spring / counter weight</b> For article numbers and lengths see pages 176 – 178 light grille / cable concept	01.03.2019 –		Unit(s) _____	/ each
		<b>9.19 Bridge plug snap 8</b>	01.03.2019 –	4980188	Unit(s) _____	/ each
	*	<b>9.20 Distributor 6 x M8 snap</b> For article numbers and lengths see pages 176 – 178 light grille / cable concept	01.03.2019 –		Unit(s) _____	/ each
		<b>9.21 Complete operator support bracket</b>	01.03.2019 –	4990800	Unit(s) _____	/ each
	*	<b>9.22 Complete shaft</b>	01.03.2019 –	4981628	Unit(s) _____ _____	/ m / each
		<b>9.23 Shaft support</b>	01.03.2019 –	4990877	Unit(s) _____	/ each
		<b>9.24 Grooved ball-bearing ASPFL 208</b>	01.03.2019 –	159403	Unit(s) _____	/ each

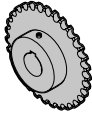
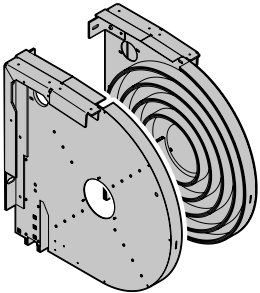
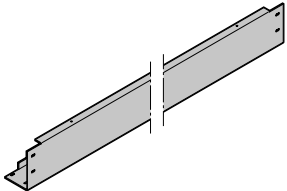
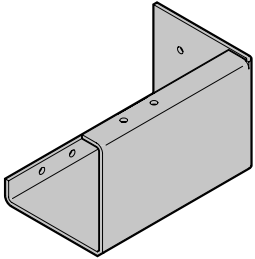
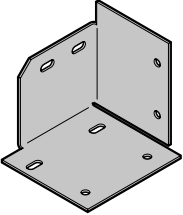
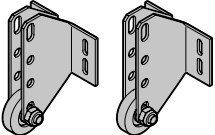
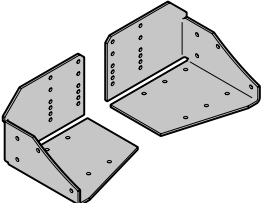

\* State purchase order number  
Surcharge for high-quality wet coating panel (see page 173)

# 9. High-Speed Door HS 5012 PU 42 S

Article	Item	Description	Production period	Art. no.	Quantity	€
	<b>9.25</b>	<b>Chain sprocket</b>	01.03.2019 –	4990808	Unit(s) _____	/ each
	*	<b>9.26 Complete spiral support</b>			Unit(s)	
		Right, LDH ≤ 4500	01.03.2019 – 31.05.2025	4981671	_____	/ each
			01.06.2025 –	7992831	_____	/ each
		Left, LDH ≤ 4500	01.03.2019 – 31.05.2025	4981672	_____	/ each
			01.06.2025 –	7992832	_____	/ each
		Right, LDH ≤ 5000	01.03.2019 – 31.05.2025	4981673	_____	/ each
			01.06.2025 –	7992833	_____	/ each
	Left, LDH ≤ 5000	01.03.2019 – 31.05.2025	4981674	_____	/ each	
		01.06.2025 –	7992834	_____	/ each	
	*	<b>9.27 Reinforcement profile</b>			Unit(s)	
		Without cladding	01.03.2019 – 31.05.2025	4981629	_____	/ m
		With cladding	01.03.2019 – 31.05.2025	4981630	_____	/ m
		Rear (3-sided cladding only)	01.03.2019 – 31.05.2025	4981631	_____	/ m
	<b>9.28</b>	<b>Reinforcement profile support</b>	01.03.2019 – 31.05.2025	4981654	Unit(s) _____	/ each
		<b>9.29 Rear reinforcement profile</b> (for 3-sided cladding only)			Unit(s)	
		Right	01.03.2019 – 31.05.2025	4981724	_____	/ each
		Left	01.03.2019 – 31.05.2025	4981725	_____	/ each
	<b>9.30</b>	<b>Complete pressure roller</b> (2 units)	01.03.2019 –	4981632	Unit(s) _____	/ each
		<b>9.31 Support bracket</b>			Unit(s)	
		For pressure roller Used without cladding and 2-sided cladding				
		In the case of 3-sided cladding, the reinforcement profile support takes over this function.	01.03.2019 – 31.05.2025	4981726	_____	/ each
		Right	01.06.2025 –	7992709	_____	/ each
	Left	01.06.2025 –	7992710	_____	/ each	

\* State purchase order number  
Surcharge for high-quality wet coating panel (see page 173)

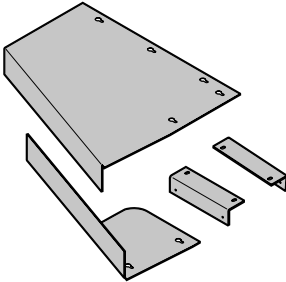
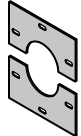
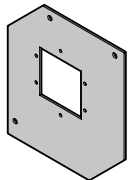
# 9. High-Speed Door HS 5012 PU 42 S

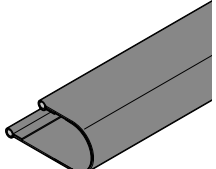
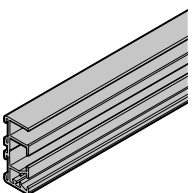
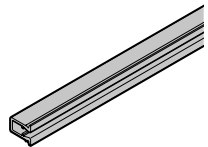
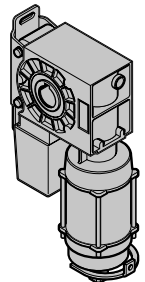
Article	Item	Description	Production period	Art. no.	Quantity	€
	<b>9.32</b>	<b>Cladding, complete</b>	01.03.2019 – 31.05.2025 01.06.2025 –	4981633 7992986	Unit(s) _____ _____	/ each / each
	<b>9.33</b>	<b>Retaining plate for bearing</b> per door (2 units)	01.03.2019 –	4981284	Unit(s) _____	/ each
	*	<b>9.34</b> <b>Sheet bearing</b>	01.03.2019 –	4981655	Unit(s) _____	/ each
	<b>9.35</b>	<b>Ball-bearing with groove</b>	01.03.2019 –	158993	Unit(s) _____	/ each
	*	<b>9.36</b> <b>Curtain loop complete</b> 80, without ThermoFrame 100, with ThermoFrame	01.03.2019 – 01.03.2019 –	4991415 4991342	Unit(s) _____ _____	/ m / m
	*	<b>9.37</b> <b>Sealing frame channel</b> 4000 mm 5000 mm 6000 mm	01.03.2019 – 01.03.2019 – 01.03.2019 –	4991263 4991770 4991426	Unit(s) _____ _____ _____	/ each / each / each
	*	<b>9.38</b> <b>Sealing frame clips</b> 4000 mm 5000 mm 6000 mm	01.03.2019 – 01.03.2019 – 01.03.2019 –	4991264 4991771 4991427	Unit(s) _____ _____ _____	/ each / each / each
	*	<b>9.39</b> <b>Operator</b>			Unit(s) _____	/ each

\* State purchase order number  
Surcharge for high-quality wet coating panel (see page 173)

# 9. High-Speed Door HS 5012 PU 42 S

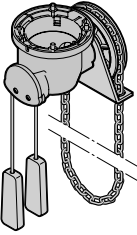
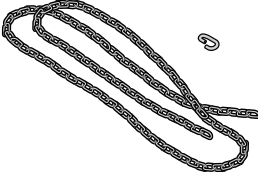
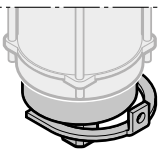
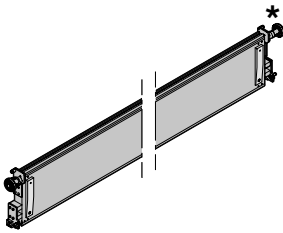
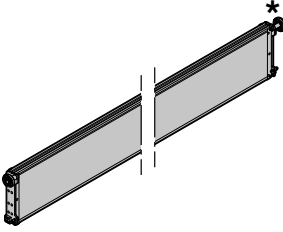
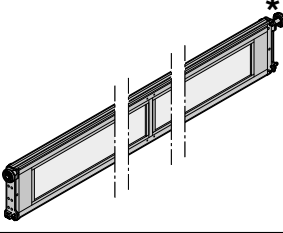
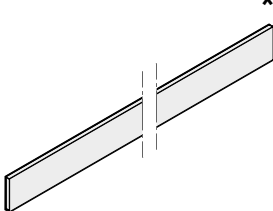
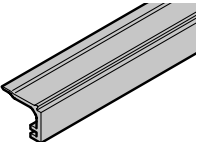
Article	Item	Description	Production period	Art. no.	Quantity	€
	<b>9.40</b>	<b>Emergency hand chain gearbox</b>	01.03.2019 –	158171	Unit(s) _____	/ each
	<b>9.41</b>	<b>hand chain 10 m</b> With chain link	01.03.2019 –	4982733	Unit(s) _____	/ each
	<b>9.42</b>	<b>Brake 11 Nm</b> <b>24 V LH U</b>	01.03.2019 –	4982120	Unit(s) _____	/ each
	<b>9.43</b>	<b>Top panel, complete with alignment mechanism</b>  Section height: 250 mm Standard version: RAL 9006	01.03.2019 –	4981634	Unit(s) _____	/ m / each
	<b>9.44</b>	<b>Inclination panel</b>  Section height: 250 mm Standard version: RAL 9006	01.03.2019 –	4981635	Unit(s) _____	/ m / each
	<b>9.45</b>	<b>Complete window profile</b>  Section height: 250 mm Standard version: RAL 9006	01.03.2019 –	4981636	Unit(s) _____	/ m / each
	<b>9.46</b>	<b>Double pane</b> Section height: 250 mm	01.03.2019 –		Unit(s) _____	/ each
	<b>9.47</b>	<b>Glazing bead</b>  Short, 160.8 mm long, per / m	01.03.2019 – 01.03.2019 –	4992192 4992194	Unit(s) _____ _____	/ each / m

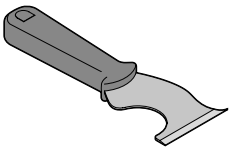
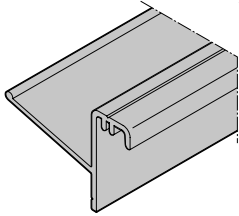
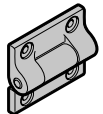
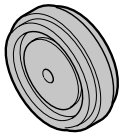
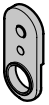
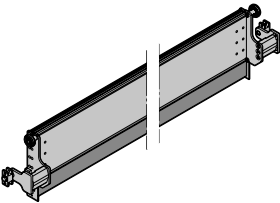
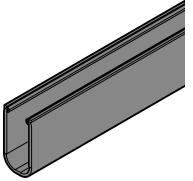
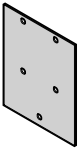
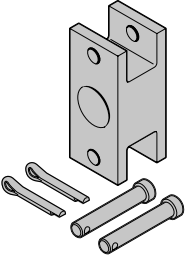

\* State purchase order number  
Surcharge for high-quality wet coating panel (see page 173)

## 9. High-Speed Door HS 5012 PU 42 S

Article	Item	Description	Production period	Art. no.	Quantity	€
	9.48	Hand scraper	01.03.2019 –	4981136	Unit(s) _____	/ each
	* 9.49	Panel lintel seal	01.03.2019 –	4991922	Unit(s) _____	/ each
	9.50	Complete centre hinge With screws  black Silver	01.03.2019 – 01.03.2019 –	4991905 4991904	Unit(s) _____ _____	/ each / each
	9.51	Roller with band For panels	01.03.2019 –	4990818	Unit(s) _____	/ each
	9.52	Complete hinge connector	01.03.2019 –	4981937	Unit(s) _____	/ each
	* 9.53	Bottom part Complete	01.03.2019 –	4981637	Unit(s) _____	/ m / each
	* 9.54	Rubber profile Velcro strap (additionally required: Velcro strap 1 m)	01.03.2019 – 01.03.2011 –	4980601 159601	Unit(s) _____ _____	/ m / m
	9.55	UPVC canopy	01.03.2019 –	4992208	Unit(s) _____	/ each
	9.56	Complete chain connection  Left Right	01.03.2019 – 01.03.2019 –	7992808 7992807	Unit(s) _____ _____	/ each / each

\* State purchase order number  
Surcharge for high-quality wet coating panel (see page 173)

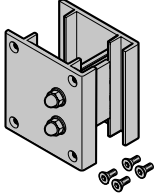
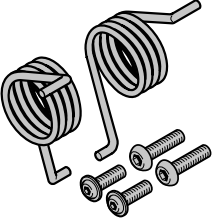
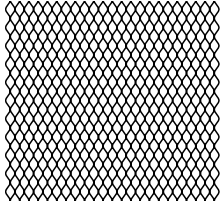
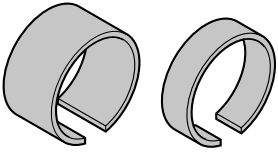
# 9. High-Speed Door HS 5012 PU 42 S

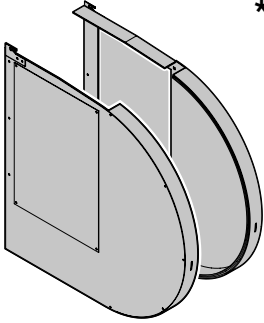
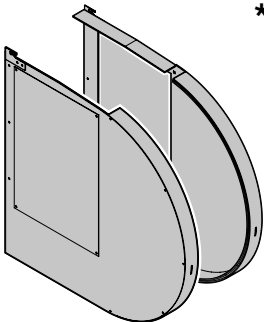
Article	Item Description	Production period	Art. no.	Quantity	€
	<b>9.57 Fixing clip</b> To hold the curtain in place when exchanging panels	01.03.2019 –	4990854	Unit(s) _____	/ each
	<b>9.58 Replacement of leg springs</b>	01.03.2019 –	4981012	Unit(s) _____	/ each
	<b>9.59 Ventilation grille</b>	01.03.2019 –	4981282	Unit(s) _____	/ m. / each
	<b>9.60 distance sleeve</b> 27 mm 30 mm 10 mm 14 mm	01.01.2016 – 30.11.2018 01.12.2018 – 01.01.2016 – 30.11.2018 01.12.2018 –	4991434 4991805 4991703 4991438	Unit(s) _____ _____ _____ _____	/ each / each / each / each
	<b>9.61 Adjusting ring</b>	01.01.2016 –	159163	Unit(s) _____	/ each
	* <b>9.62 Side cover</b> For cladding <b>right, operator</b> right LDB ≤ 4500 mm left LDB ≤ 4500 mm right LDB ≤ 5000 mm left LDB ≤ 5000 mm Self-tapping screws M6 × 12 required (see item 9.9)	01.06.2025 – 01.06.2025 – 01.06.2025 – 01.06.2025 –	7992784 7992785 7992786 7992787	Unit(s) _____ _____ _____ _____	/ each / each / each / each
	* <b>9.63 Side cover</b> For cladding <b>left, operator</b> right LDB ≤ 4500 mm left LDB ≤ 4500 mm right LDB ≤ 5000 mm left LDB ≤ 5000 mm Self-tapping screws M6 × 12 required (see item 9.9)	01.06.2025 – 01.06.2025 – 01.06.2025 – 01.06.2025 –	7992929 7992930 7992902 7992903	Unit(s) _____ _____ _____ _____	/ each / each / each / each

\* State purchase order number  
Surcharge for high-quality wet coating panel (see page 173)

## 9. High-Speed Door HS 5012 PU 42 S

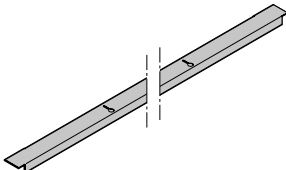
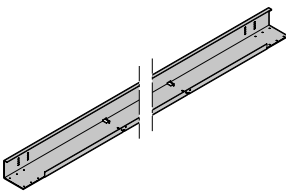
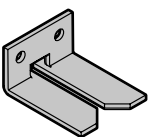
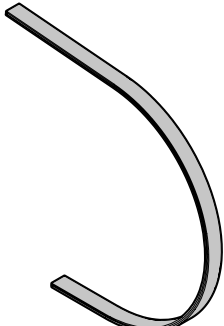
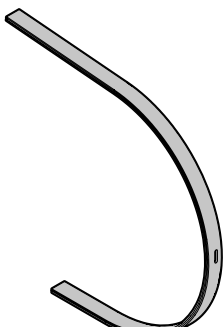
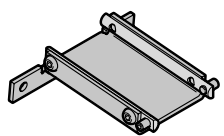
Article	Item Description	Production period	Art. no.	Quantity	€
	<p><b>* 9.64 Reinforcement profile</b></p> <p>top, without cladding</p>	01.06.2025 –	7992713	Unit(s)	/ m
	<p>top cladding</p>	01.06.2025 –	7992794		/ each
	<p><b>* 9.65 Reinforcement profile</b></p> <p>bottom, without cladding</p>	01.06.2025 –	7992801	Unit(s)	/ m
	<p>bottom <sup>1)</sup> cladding</p> <p><sup>1)</sup> Threading for cladding required (see item 9.66)</p>	01.06.2025 –	7992793		/ m
	<p><b>9.66 Threading for cladding</b></p> <p>30 × 60 × 50 mm</p>	01.06.2025 –	7991484	Unit(s)	/ each
	<p>30 × 90 × 50 mm</p> <p>Self-tapping screws M6 × 12 required (see item 9.9)</p>	01.06.2025 –	7991483		/ each
	<p><b>9.67 Support yoke</b></p> <p>For cladding</p>			Unit(s)	
	<p>LDH ≤ 4500</p> <p>LDH &gt; 4500, LDH ≤ 5000</p> <p>Connection for support yoke required (see item 9.69)</p>	01.06.2025 –	7992766		/ each
	<p><b>9.68 Support yoke</b></p> <p>Without cladding</p>			Unit(s)	
	<p>LDH ≤ 4500</p> <p>LDH &gt; 4500, LDH ≤ 5000</p> <p>Connection for support yoke required (see item 9.69)</p>	01.06.2025 –	7992769		/ each
	<p><b>9.69 Connection for support yoke</b></p> <p>Self-tapping screws M6 × 12 required (see item 9.9)</p>	01.06.2025 –	7992908	Unit(s)	/ each





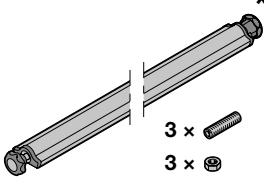
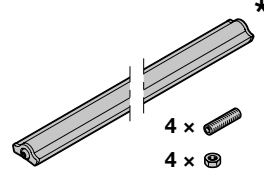
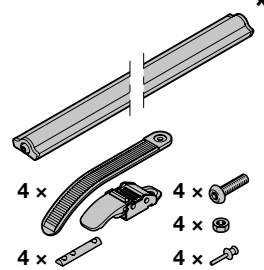
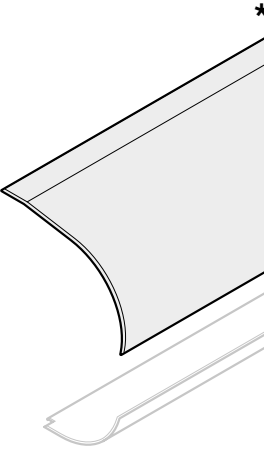
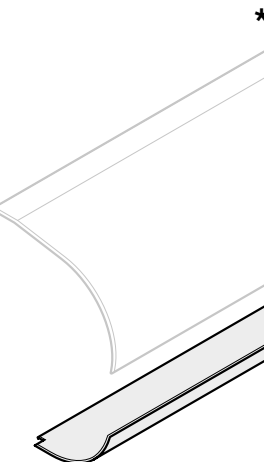

\* State purchase order number  
 Surcharge for high-quality wet coating panel (see page 173)

# 9. High-Speed Door HS 5012 PU 42 S

Article	Item	Description	Production period	Art. no.	Quantity	€
	<b>9.70</b>	<b>Top crossbar, complete</b>	01.06.2025 –	7992898	Unit(s) _____ _____	/ m / each
	<b>9.71</b>	<b>Centre crossbar, complete</b>	01.06.2025 –	7992899	Unit(s) _____ _____	/ m / each
	<b>9.72</b>	<b>Bottom crossbar, complete</b>	01.06.2025 –	7992900	Unit(s) _____ _____	/ m / each
	<b>9.73</b>	<b>Top pane</b> For cladding  Without foil coating With foil coating Based on RAL 9006 White aluminium Based on RAL 1018 Zinc yellow Based on RAL 3002 Camine red Based on RAL 5010 Gentian blue Based on RAL 2004 Pure orange based on RAL 9005 Jet black	01.06.2025 – 01.06.2025 –	7992897 7992897	Unit(s) _____ _____	/ each / each
	<b>9.74</b>	<b>Bottom pane</b> For cladding  Without foil coating With foil coating Based on RAL 9006 White aluminium Based on RAL 1018 Zinc yellow Based on RAL 3002 Camine red Based on RAL 5010 Gentian blue Based on RAL 2004 Pure orange based on RAL 9005 Jet black	01.06.2025 – 01.06.2025 –	7992896 7992896	Unit(s) _____ _____	/ each / each

\* State purchase order number  
Surcharge for high-quality wet coating panel (see page 173)

# 9. High-Speed Door HS 5012 PU 42 S

Article	Item	Description	Production period	Art. no.	Quantity	€
4 x 	7 x 	<b>9.75 Accessories fixing material</b> PC cladding	01.06.2025 –	7992863	Unit(s)	/each
6 x 	7 x 				_____	
36 x 	3 x 					

\* State purchase order number  
 Surcharge for high-quality wet coating panel (see page 173)

# HS 5015 PU H 67

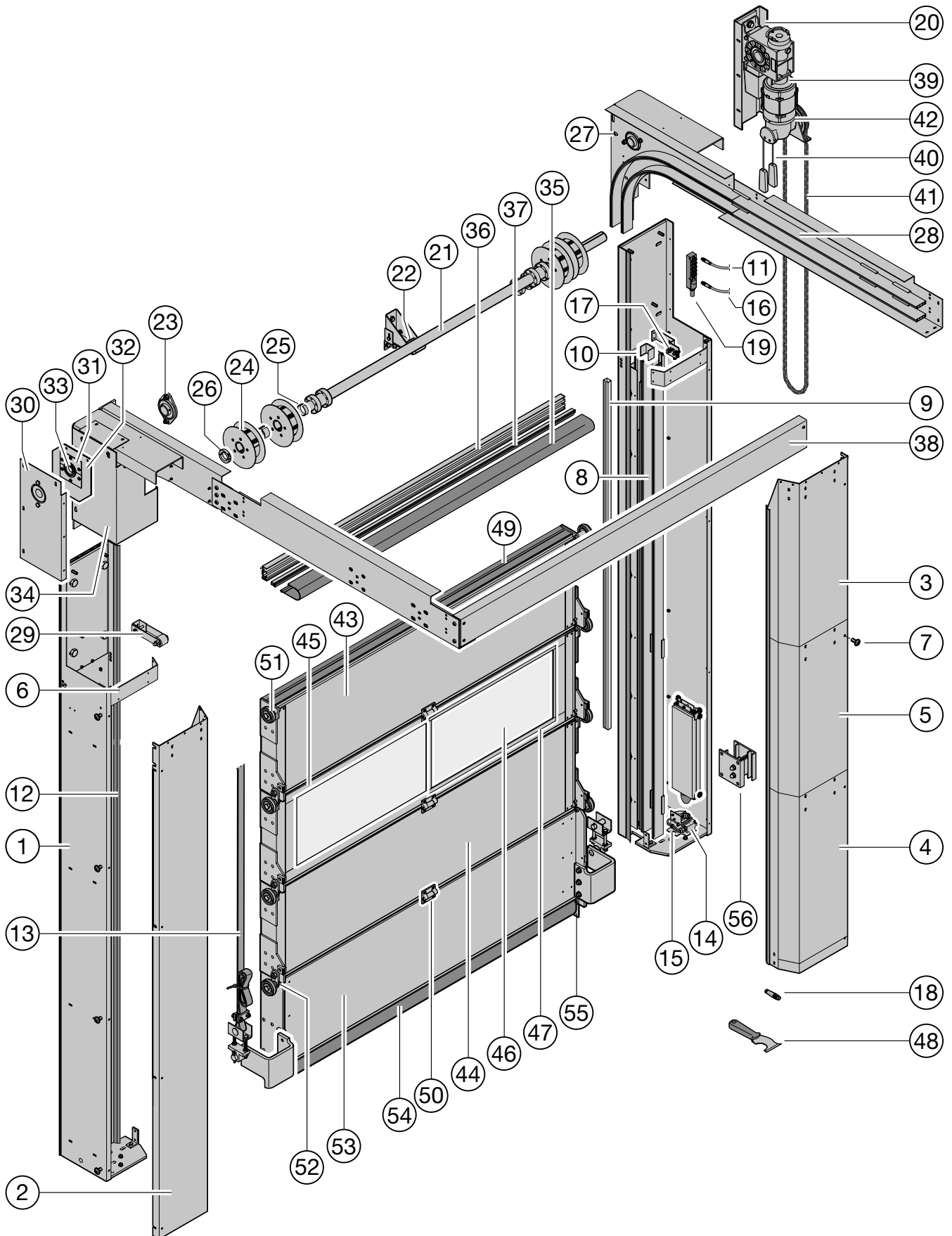

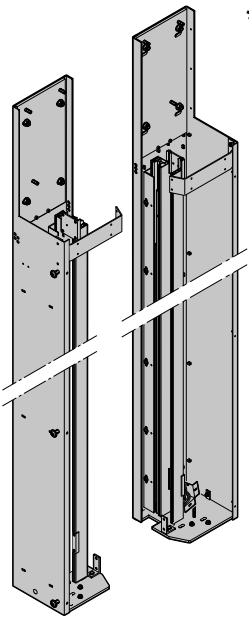
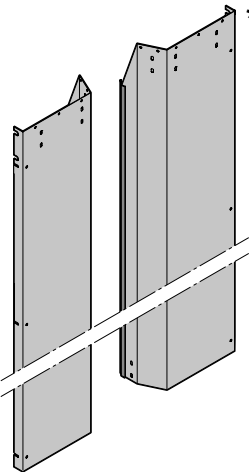
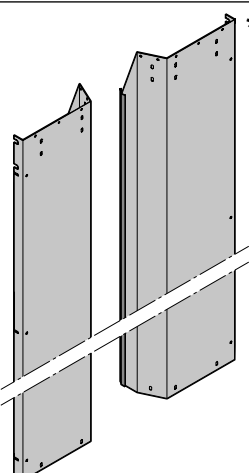

# 10. High-Speed Door HS 5015 PU H 67

Article	Item	Description	Production period	Art. no.	Quantity	€
	*	<b>10.1 Side element</b>			Unit(s)	
		Right	01.01.2016 –	4992173	_____	/ each
		Left	01.01.2016 –	4992174	_____	/ each
	*	<b>10.2 Cover, 1-part</b>			Unit(s)	
		LH ≤ 3745 mm				
		Right	01.01.2016 – 30.11.2018	4991912	_____	/ m
			01.12.2018 –	4981661	_____	/ each
		Left	01.01.2016 – 30.11.2018	4991913	_____	/ m
			01.12.2018 –	4981662	_____	/ each
	*	<b>10.3 Top cover, 2-part</b>			Unit(s)	
		LH > 3745 mm				
		Right	01.01.2016 – 30.11.2018	4991916	_____	/ m
			01.12.2018 –	4981663	_____	/ each
		Left	01.01.2016 – 30.11.2018	4991919	_____	/ m
			01.12.2018 –	4981664	_____	/ each



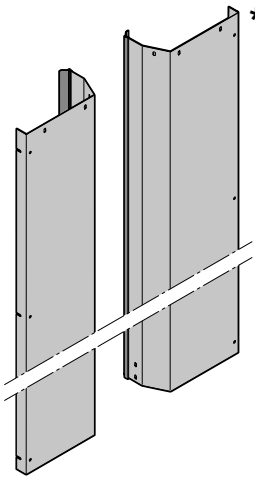
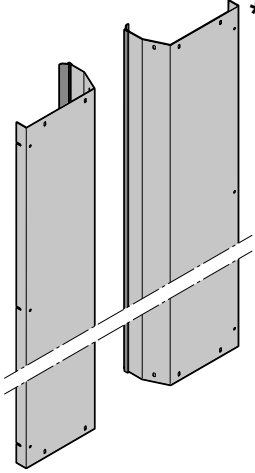
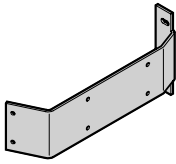

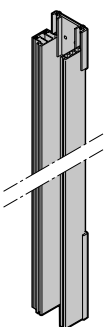

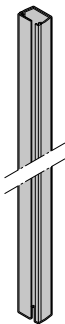

\* State purchase order number  
 Surcharge for high-quality wet coating panel (see page 173)

# 10. High-Speed Door HS 5015 PU H 67

Article	Item	Description	Production period	Art. no.	Quantity	€
	*	<b>10.4 Bottom cover, 2-part</b>			Unit(s)	
		LH > 3745 mm Right	01.01.2016 –	4991915	_____	/ m / each
		Left	01.01.2016 –	4991918	_____	/ m / each
	*	<b>10.5 Centre cover, 3-part</b>			Unit(s)	
		LH > 6245 mm Right	01.01.2016 –	4991914	_____	/ m / each
		Left	01.01.2016 –	4991917	_____	/ m / each
		<b>10.6 Cover bar</b>	01.01.2016 –	4991910	Unit(s) _____	/ each
 50x		<b>10.7 Self-tapping screws M6 x 12</b> Screws for cover		4992181	Unit(s) _____	/ each
	*	<b>10.8 Complete aluminium profile guide</b>			Unit(s)	
		Right	01.01.2016 –	4980666	_____	/ m / each
		Left	01.01.2016 –	4980667	_____	/ m / each





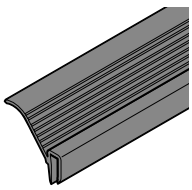
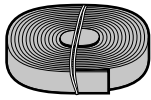
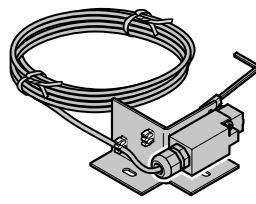
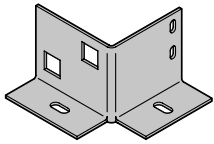

\* State purchase order number  
Surcharge for high-quality wet coating panel (see page 173)

# 10. High-Speed Door HS 5015 PU H 67

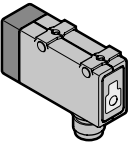
Article	Item	Description	Production period	Art. no.	Quantity	€
	*	<b>10.9 Light grille</b>  For article numbers and lengths see pages 176 – 178 light grille / cable concept  When replacing a light grille, vinyl foam adhesive tapes are also required.	01.01.2016 – 31.05.2021 01.06.2021 –		Unit(s) _____ _____	/ each / each
6x   6x 6x   6x 12x   1x		<b>10.10 Light grille replacement accessories</b>  From 01.06.2021 onwards, the bag is required when replacing the light grille.	01.06.2021 –	4982111	Unit(s) _____	/ each
	*	<b>10.11 Snap cable, white, light grille</b>  For article numbers and lengths see pages 176 – 178 light grille / cable concept	01.01.2016 –		Unit(s) _____	/ each
	*	<b>10.12 Seal for guide</b>  Additional 2 x per side element required  4000 mm 5000 mm 6000 mm	01.01.2016 – 01.01.2016 – 01.01.2016 –	4991585 4991586 4991490	Unit(s) _____ _____ _____	/ each / each / each
		<b>10.13 Flat belt 30 mm</b>  For curtain and weight	01.01.2016 –	4991432	Unit(s) _____	/ m
		<b>10.14 Counter weight button with wiring snapM8</b>  Right Left	01.01.2016 – 01.01.2016 –	4981665 4981666	Unit(s) _____ _____	/ each / each
		<b>10.15 Button support</b>  Right Left	05.11.2018 – 05.11.2018 –	4981585 4981586	Unit(s) _____ _____	/ each / each

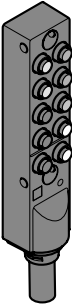

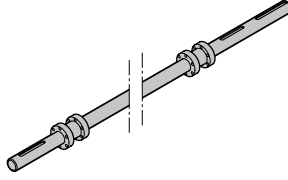
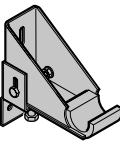
\* State purchase order number  
Surcharge for high-quality wet coating panel (see page 173)

# 10. High-Speed Door HS 5015 PU H 67

Article	Item	Description	Production period	Art. no.	Quantity	€
	*	<b>10.16 Snap cable</b> blue, spring / counter weight yellow, belt monitoring For article numbers and lengths see pages 176 – 178 light grille / cable concept	01.01.2016 – 01.01.2016 –		Unit(s) _____ _____	/ each / each
		<b>10.17 Light button reflection</b> Discontinued articles The support bracket of the existing switch is not compatible with the new switch. You need the new support bracket to replace the switch (7992043, €9.60). For curtain belt monitoring	01.01.2016 – 31.10.2024  01.11.2024 –	4991409  4982897	Unit(s) _____ _____	/ each / each
		<b>10.18 Bridge plug snap8</b>	01.01.2016 –	4980188	Unit(s) _____	/ each
	*	<b>10.19 Distributor 10 x M8 snap</b> For article numbers and lengths see pages 176 – 178 light grille / cable concept	01.01.2016 –		Unit(s) _____	/ each
		<b>10.20 Complete operator support bracket</b>	01.01.2016 –	4990800	Unit(s) _____	/ each
	*	<b>10.21 Complete shaft</b>	01.01.2016 – 30.11.2018  01.12.2018 –	4980668  4981490	Unit(s) _____ _____ _____	/ m / each / m / each
		<b>10.22 Shaft support</b>	01.01.2016 –	4990877	Unit(s) _____	/ each
		<b>10.23 Grooved ball-bearing ASPFL 208</b>	01.01.2016 –	159403	Unit(s) _____	/ each

\* State purchase order number  
Surcharge for high-quality wet coating panel (see page 173)

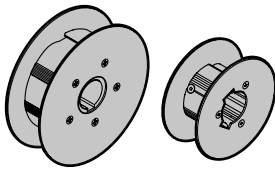
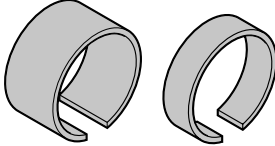
# 10. High-Speed Door HS 5015 PU H 67

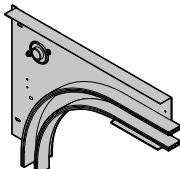
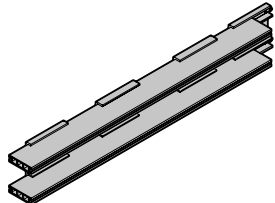
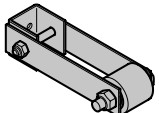
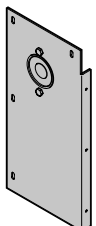
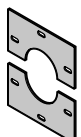
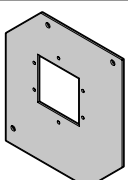
Article	Item Description	Production period	Art. no.	Quantity	€
	<b>10.24 Pulley</b> Ø 145 Ø 70	01.01.2016 – 01.01.2016 –	4991433 4991632	Unit(s) _____ _____	/ each / each
	<b>10.25 distance sleeve</b> 27 mm 30 mm 14 mm 12 mm	01.01.2016 – 30.11.2018 01.12.2018 – 01.01.2016 – 30.11.2018 01.12.2018 –	4991434 4991805 4991438 4981667	Unit(s) _____ _____ _____ _____	/ each / each / each / each
	<b>10.26 Adjusting ring</b>	01.01.2016 –	159163	Unit(s) _____	/ each
	* <b>10.27 Complete support curve</b> Right Left	01.01.2016 – 01.01.2016 –	4980669 4980670	Unit(s) _____ _____	/ each / each
	* <b>10.28 Complete horizontal guide</b> Right Left	01.01.2016 – 01.01.2016 –	4980671 4980672	Unit(s) _____ _____	/ m / m
	<b>10.29 Complete return pulley</b>	01.01.2016 –	4991214	Unit(s) _____	/ each
	<b>10.30 Complete cladding, bearing side</b> Right Left	01.01.2016 – 30.11.2018 01.01.2016 – 30.11.2018	4991189 4991188	Unit(s) _____ _____	/ each / each
	<b>10.31 Retaining plate for bearing</b> per door (2 units)	01.12.2018 –	4981284	Unit(s) _____	/ each
	<b>10.32 Sheet bearing</b>	01.12.2018 –	4981655	Unit(s) _____	/ each

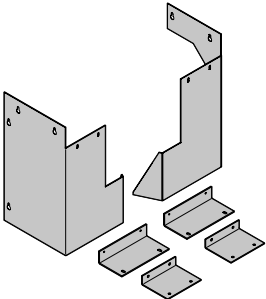
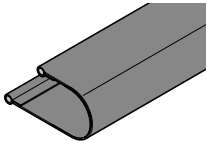
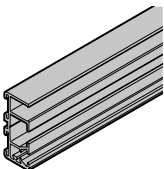
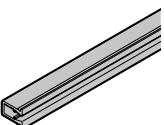
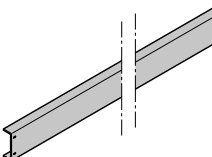
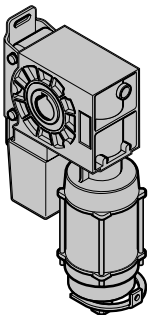

\* State purchase order number  
Surcharge for high-quality wet coating panel (see page 173)

# 10. High-Speed Door HS 5015 PU H 67

Article	Item Description	Production period	Art. no.	Quantity	€
	<b>10.33 Ball-bearing with groove</b>	01.12.2018 –	158993	Unit(s) _____	/ each
	<b>10.34 Cladding, complete</b>	01.12.2018 –	4981668	Unit(s) _____	/ each
	* <b>10.35 Curtain loop complete</b> 80, without ThermoFrame 100, with ThermoFrame	01.01.2016 – 01.01.2016 –	4991415 4991342	Unit(s) _____ _____	/ m / m
	* <b>10.36 Sealing frame channel</b> 4000 mm 5000 mm 6000 mm	01.01.2016 – 01.01.2016 – 01.01.2016 –	4991263 4991770 4991426	Unit(s) _____ _____ _____	/ each / each / each
	* <b>10.37 Sealing frame channel</b> 4000 mm 5000 mm 6000 mm	01.01.2016 – 01.01.2016 – 01.01.2016 –	4991264 4991771 4991427	Unit(s) _____ _____ _____	/ each / each / each
	* <b>10.38 Transverse cross strut</b>	01.01.2016 –	4991911	Unit(s) _____	/ m
	* <b>10.39 Operator</b>			Unit(s) _____	/ each

\* State purchase order number  
Surcharge for high-quality wet coating panel (see page 173)

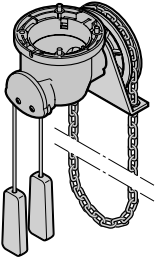
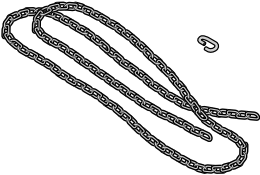
# 10. High-Speed Door HS 5015 PU H 67

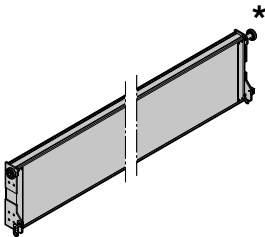
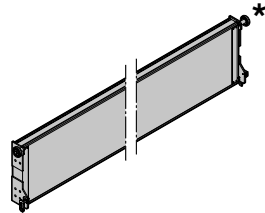
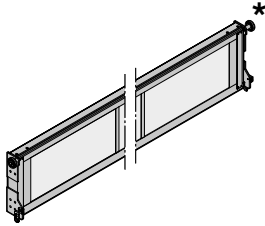
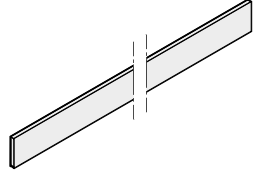
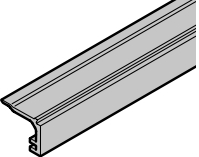
Article	Item Description	Production period	Art. no.	Quantity	€
	<b>10.40 Emergency hand chain gearbox</b>	01.01.2016 –	158171	Unit(s) _____	/ each
	<b>10.41 hand chain 10 m</b> With chain link	01.01.2016 –	4982733	Unit(s) _____	/ each
	<b>10.42 Brake 11 Nm 24 V LH U</b>	01.01.2016 –	4982120	Unit(s) _____	/ each
	<b>10.43 Complete top panel</b> Section height 375 mm Standard version: RAL 9006	01.01.2016 –	4980673	Unit(s) _____	/ m / each
	<b>10.44 Inclination panel</b> Section height 375 mm Standard version: RAL 9006	01.01.2016 –	4980568	Unit(s) _____	/ m / each
	<b>10.45 Complete window profile</b> Section height 375 mm Standard version: RAL 9006 Triple glazing	01.01.2016 –	4980566	Unit(s) _____	/ m / each
	<b>10.46 Triple pane</b>	01.01.2016 –		Unit(s) _____	/ each
	<b>10.47 Glazing bead</b> Short, 255.8 mm long, per / m	01.01.2016 – 01.01.2016 –	4992193 4992194	Unit(s) _____ _____	/ each / m

\* State purchase order number  
Surcharge for high-quality wet coating panel (see page 173)

# 10. High-Speed Door HS 5015 PU H 67

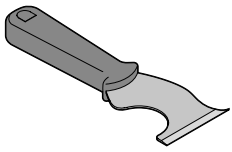
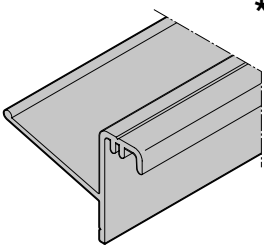
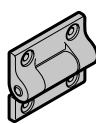
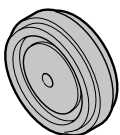
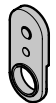
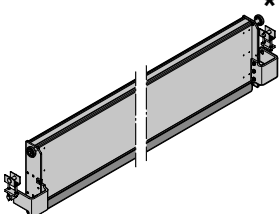
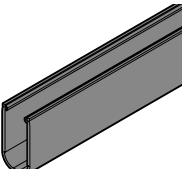
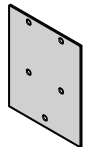
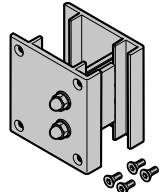
Article	Item Description	Production period	Art. no.	Quantity	€
	<b>10.48 Hand scraper</b>	01.03.2019 –	4981136	Unit(s) _____	/ each
 *	<b>10.49 Panel lintel seal</b>	01.03.2019 –	4991922	Unit(s) _____	/ each
	<b>10.50 Complete centre hinge</b> With screws  black Silver	01.01.2016 – 01.01.2016 –	4991905 4991904	Unit(s) _____ _____	/ each / each
	<b>10.51 Roller with band</b>  For the counter weight For panels	01.01.2016 – 01.01.2016 –	159413 4990818	Unit(s) _____ _____	/ each / each
	<b>10.52 Complete hinge connector</b>	01.01.2016 –	4981937	Unit(s) _____	/ each
 *	<b>10.53 Bottom part Complete</b>	01.01.2016 –	4980674	Unit(s) _____	/ m / each
 *	<b>10.54 Rubber profile Velcro strap</b> (additionally required: Velcro strap 1 m)	01.01.2016 – 01.03.2011 –	4980601 159601	Unit(s) _____ _____	/ m / m
	<b>10.55 UPVC canopy</b>	01.01.2016 –	4992176	Unit(s) _____	/ each
	<b>10.56 Fixing clip</b> To hold the curtain in place when exchanging panels	01.01.2016 –	4990854	Unit(s) _____	/ each

\* State purchase order number  
Surcharge for high-quality wet coating panel (see page 173)

# HS 6015 PU V 67

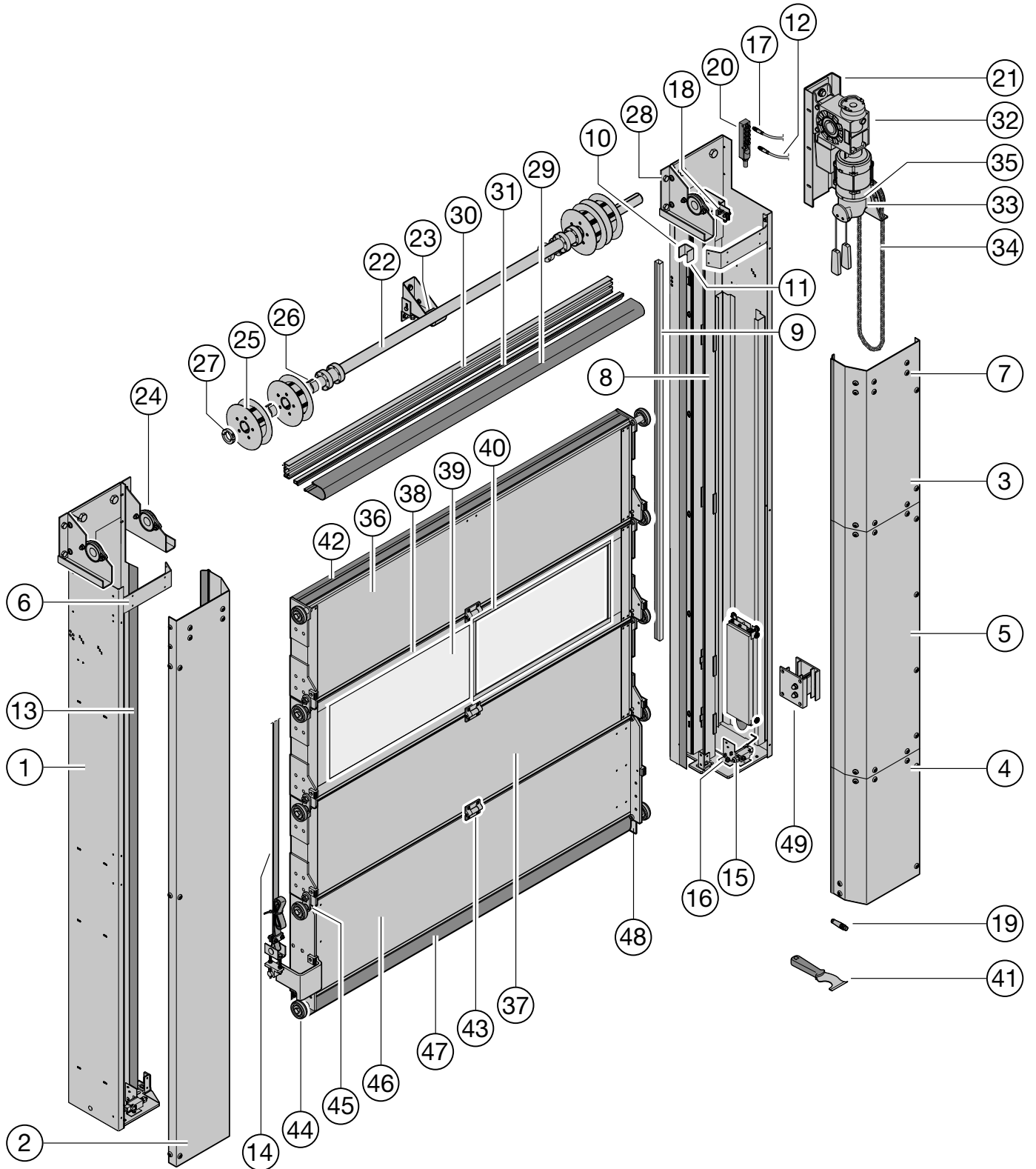

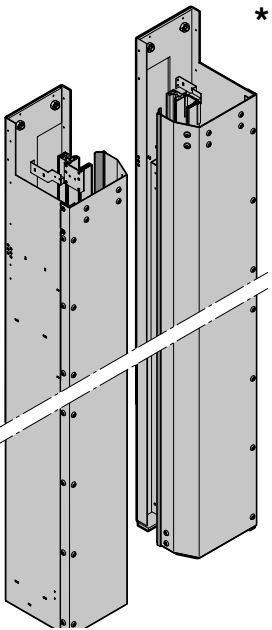
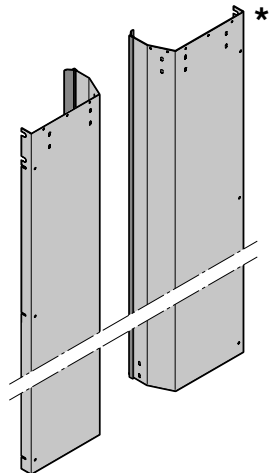
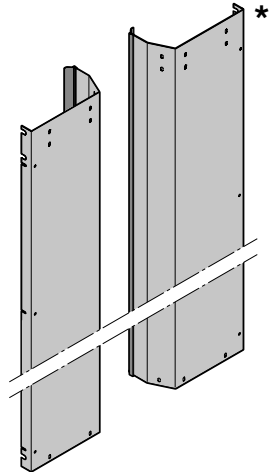

# 11. High-Speed Door HS 6015 PU V 67

Article	Item	Description	Production period	Art. no.	Quantity	€
	*	<b>11.1 Side element</b>			Unit(s)	
		Right	01.01.2016 –	4980660	_____	/ each
		Left	01.01.2016 –	4980661	_____	/ each
	*	<b>11.2 Cover, 1-part</b>			Unit(s)	
		LDH ≤ 1500 mm				
		Right	01.01.2016 –	4980662	_____	/ m
		Left	01.01.2016 –	4980663	_____	/ m
						/ each
	*	<b>11.3 Top cover, 2-part</b>			Unit(s)	
		LDH ≤ 3000 mm				
		Right	01.01.2016 –	4980675	_____	/ m
		Left	01.01.2016 –	4980677	_____	/ m
						/ each

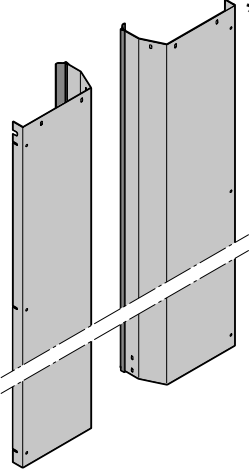
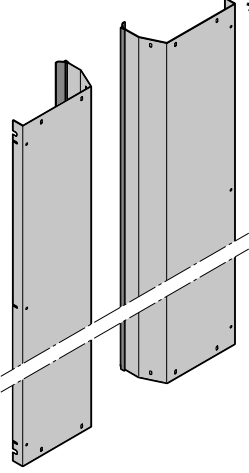
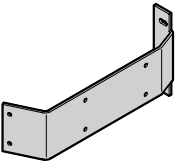

\* State purchase order number  
 Surcharge for high-quality wet coating panel (see page 173)

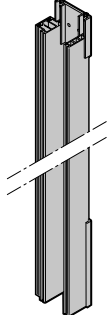
# 11. High-Speed Door HS 6015 PU V 67

Article	Item	Description	Production period	Art. no.	Quantity	€
	*	<b>11.4 Bottom cover, 2-part</b>			Unit(s)	
		LDH ≤ 3000 mm Right	01.01.2016 –	4980676	_____	/ m / each
		Left	01.01.2016 –	4980678	_____	/ m / each
	*	<b>11.5 Centre cover, 3-part</b>			Unit(s)	
		LDH > 3000 mm Right	01.01.2016 –	4980679	_____	/ m / each
		Left	01.01.2016 –	4980680	_____	/ m / each
		<b>11.6 Cover bar</b>	01.01.2016 –	4991910	_____	/ each
		<b>11.7 Self-tapping screws M6 x 12</b> Screws for cover		4992181	_____	/ each
	*	<b>11.8 Complete aluminium profile guide</b>			Unit(s)	
		Right	01.01.2016 –	4980681	_____	/ m / each
		Left	01.01.2016 –	4980682	_____	/ m / each



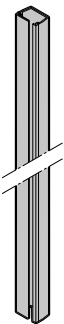
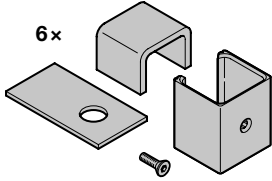
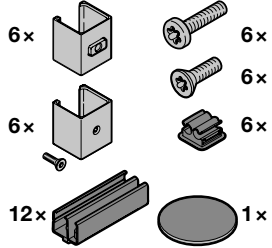

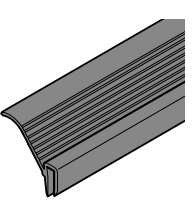
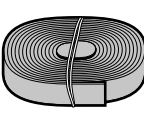
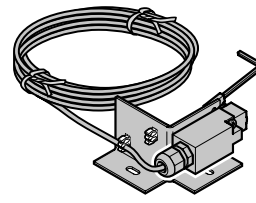
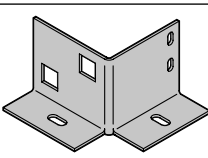

\* State purchase order number  
Surcharge for high-quality wet coating panel (see page 173)

# 11. High-Speed Door HS 6015 PU V 67

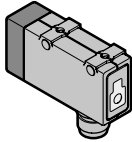
Article	Item	Description	Production period	Art. no.	Quantity	€
	*	<b>11.9 Light grille</b>  For article numbers and lengths see pages 176 – 178 light grille / cable concept  When replacing a light grille, vinyl foam adhesive tapes are also required.	01.01.2016 – 31.05.2021 01.06.2021 –		Unit(s) _____ _____	/ each  / each
	6x	<b>11.10 Holder for light grille</b>	01.01.2017 – 31.05.2021	4981440	Unit(s) _____	/ each
	6x 6x 12x 6x 6x 1x	<b>11.11 Light grille replacement accessories</b>  From 01.06.2021 onwards, the bag is required when replacing the light grille.	01.06.2021 –	4982111	Unit(s) _____	/ each
	*	<b>11.12 Snap cable, white, light grille</b>  For article numbers and lengths see pages 176 – 178 light grille / cable concept	01.01.2016 –		Unit(s) _____	/ each
	*	<b>11.13 Seal for guide</b>  Additional 2 x per side element required  4000 mm 5000 mm 6000 mm	01.01.2016 – 01.01.2016 – 01.01.2016 –	4991585 4991586 4991490	Unit(s) _____ _____ _____	/ each / each / each
		<b>11.14 Flat belt 30 mm</b>  For curtain and weight	01.01.2016 –	4991432	Unit(s) _____	/ m
		<b>11.15 Button counter weight wired snap 8</b>  Right Left	01.01.2016 – 01.01.2016 –	4981665 4981666	Unit(s) _____ _____	/ each / each
		<b>11.16 Button support</b>  Right Left	01.01.2016 – 01.01.2016 –	4981585 4981586	Unit(s) _____ _____	/ each / each

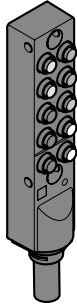

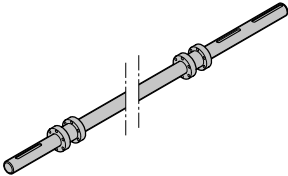
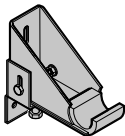
\* State purchase order number  
Surcharge for high-quality wet coating panel (see page 173)

# 11. High-Speed Door HS 6015 PU V 67

Article	Item	Description	Production period	Art. no.	Quantity	€
	*	<b>11.17 Snap cable</b> blue, spring / counter weight yellow, belt monitoring For article numbers and lengths see pages 176 – 178 light grille / cable concept	01.01.2016 – 01.01.2016 –		Unit(s) _____ _____	/ each / each
		<b>11.18 Light button reflection</b> Discontinued articles The support bracket of the existing switch is not compatible with the new switch. You need the new support bracket to replace the switch (7992042, €9.60). For curtain belt monitoring	01.08.2013 – 31.10.2024  01.11.2024 –	4991409  4982897	Unit(s) _____ _____	/ each  / each
		<b>11.19 Bridge plug snap 8</b>	01.01.2016 –	4980188	Unit(s) _____ _____	/ each
	*	<b>11.20 Distributor 10 x M8 snap</b> For article numbers and lengths see pages 176 – 178 light grille / cable concept	01.01.2016 –		Unit(s) _____ _____	/ each
		<b>11.21 Complete operator support bracket</b>	01.01.2016 –	4990800	Unit(s) _____ _____	/ each
	*	<b>11.22 Complete shaft</b>	01.01.2016 – 30.11.2018  01.12.2018 –	4980683  4981528	Unit(s) _____ _____	/ m / each / m / each
		<b>11.23 Shaft support</b>	01.01.2016 –	4990877	Unit(s) _____ _____	/ each
		<b>11.24 Grooved ball-bearing ASPFL 208</b>	01.01.2016 –	159403	Unit(s) _____ _____	/ each

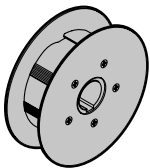

\* State purchase order number  
Surcharge for high-quality wet coating panel (see page 173)

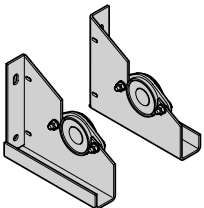
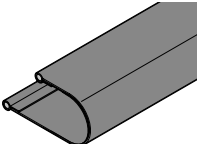
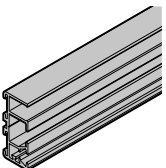
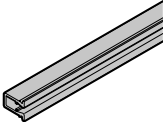
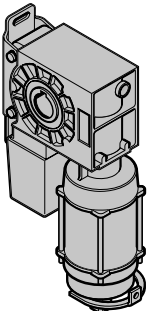
# 11. High-Speed Door HS 6015 PU V 67

Article	Item Description	Production period	Art. no.	Quantity	€
	<b>11.25 Pulley</b> Ø 145	01.01.2016 –	4991433	Unit(s) _____	/ each
	<b>11.26 distance sleeve</b> 27 mm 30 mm 12 mm	01.01.2016 – 30.11.2018 01.12.2018 – 01.12.2018 –	4991434 4991805 4981667	Unit(s) _____ _____ _____	/ each / each / each
	<b>11.27 Adjusting ring</b>	01.01.2016 –	159163	Unit(s) _____	/ each
	<b>11.28 Complete bearing support</b> Right Left	01.01.2016 – 01.01.2016 –	4991425 4991424	Unit(s) _____ _____	/ each / each
	* <b>11.29 Curtain loop complete</b> 80, without ThermoFrame 100, with ThermoFrame	01.01.2016 – 01.01.2016 –	4991415 4991342	Unit(s) _____ _____	/ m / m
	* <b>11.30 Sealing frame channel</b> 4000 mm 5000 mm 6000 mm	01.01.2016 – 01.01.2016 – 01.01.2016 –	4991263 4991770 4991426	Unit(s) _____ _____ _____	/ each / each / each
	* <b>11.31 Sealing frame channel</b> 4000 mm 5000 mm 6000 mm	01.01.2016 – 01.01.2016 – 01.01.2016 –	4991264 4991771 4991427	Unit(s) _____ _____ _____	/ each / each / each
	* <b>11.32 Operator</b>			Unit(s) _____	/ each

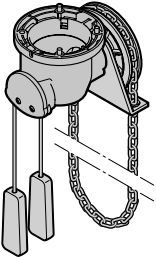
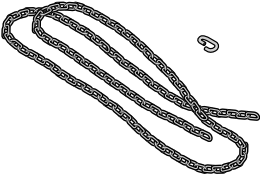

\* State purchase order number  
Surcharge for high-quality wet coating panel (see page 173)

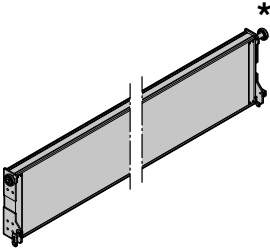
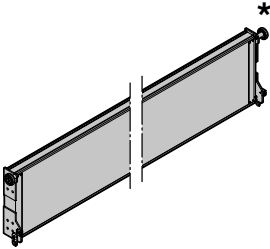
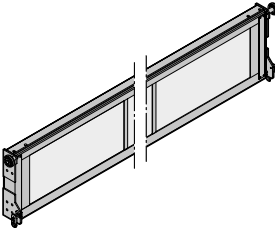
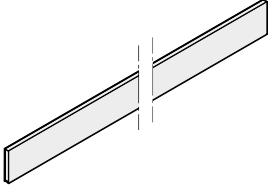
# 11. High-Speed Door HS 6015 PU V 67

Article	Item Description	Production period	Art. no.	Quantity	€
	<b>11.33 Emergency hand chain gearbox</b>	01.01.2016 –	158171	Unit(s) _____	/ each
	<b>11.34 hand chain 10 m</b> With chain link	01.01.2016 –	4982733	Unit(s) _____	/ each
	<b>11.35 Brake 11 Nm 24 V LH U</b>	01.01.2015 –	4982120	Unit(s) _____	/ each
	<b>11.36 Complete top panel</b> Section height 375 mm Standard version: RAL 9006	01.01.2016 –	4980673	Unit(s) _____	/ m / each
	<b>11.37 Inclination panel</b> Section height 375 mm Standard version: RAL 9006	01.01.2016 –	4980568	Unit(s) _____	/ m / each
	<b>11.38 Complete window profile</b> Section height 375 mm Standard version: RAL 9006 Triple glazing	01.01.2016 –	4980566	Unit(s) _____	/ m / each
	<b>11.39 Triple pane</b>	01.01.2016 –		Unit(s) _____	/ each

\* State purchase order number  
Surcharge for high-quality wet coating panel (see page 173)

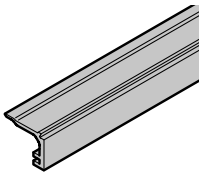
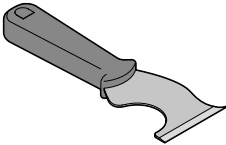
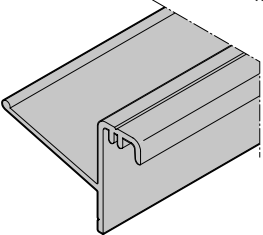
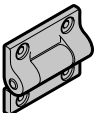
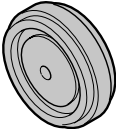
# 11. High-Speed Door HS 6015 PU V 67

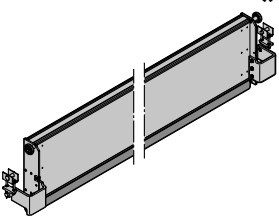
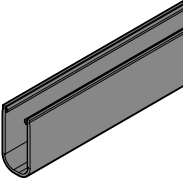
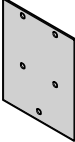
Article	Item	Description	Production period	Art. no.	Quantity	€
	*	<b>11.40 Glazing bead</b> Short, 255.8 mm Long per / m	01.01.2016 – 01.01.2016 –	4992193 4992194	Unit(s) _____ _____	/ each / m
		<b>11.41 Hand scraper</b>	01.03.2019 –	4981136	Unit(s) _____	/ each
	*	<b>11.42 Panel lintel seal</b>	01.03.2019 –	4991922	Unit(s) _____	/ each
		<b>11.43 Complete centre hinge</b> With screws  black Silver	01.01.2016 – 01.01.2016 –	4991905 4991904	Unit(s) _____ _____	/ each / each
		<b>11.44 Roller with band</b>  For the counter weight For panels	01.01.2016 – 01.01.2016 –	159413 4990818	Unit(s) _____ _____	/ each / each
		<b>11.45 Complete hinge connector</b>	01.01.2016 –	4981937	Unit(s) _____	/ each
	*	<b>11.46 Bottom part Complete</b>	01.01.2016 –	4980685	Unit(s) _____ _____	/ m / each
	*	<b>11.47 Rubber profile Velcro strap</b> (additionally required: Velcro strap 1 m)	01.01.2016 – 01.03.2011 –	4980601 159601	Unit(s) _____ _____	/ m / m
		<b>11.48 UPVC canopy</b>	01.01.2016 –	4992176	Unit(s) _____	/ each

\* State purchase order number  
Surcharge for high-quality wet coating panel (see page 173)

# 11. High-Speed Door HS 6015 PU V 67

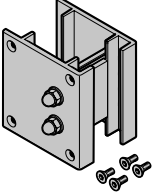
Article	Item Description	Production period	Art. no.	Quantity	€
	<b>11.49 Fixing clip</b> To hold the curtain in place when exchanging panels	01.01.2016 –	4990854	Unit(s) _____	/ each

\* State purchase order number  
 Surcharge for high-quality wet coating panel (see page 173)

# HS 5015 Acoustic H

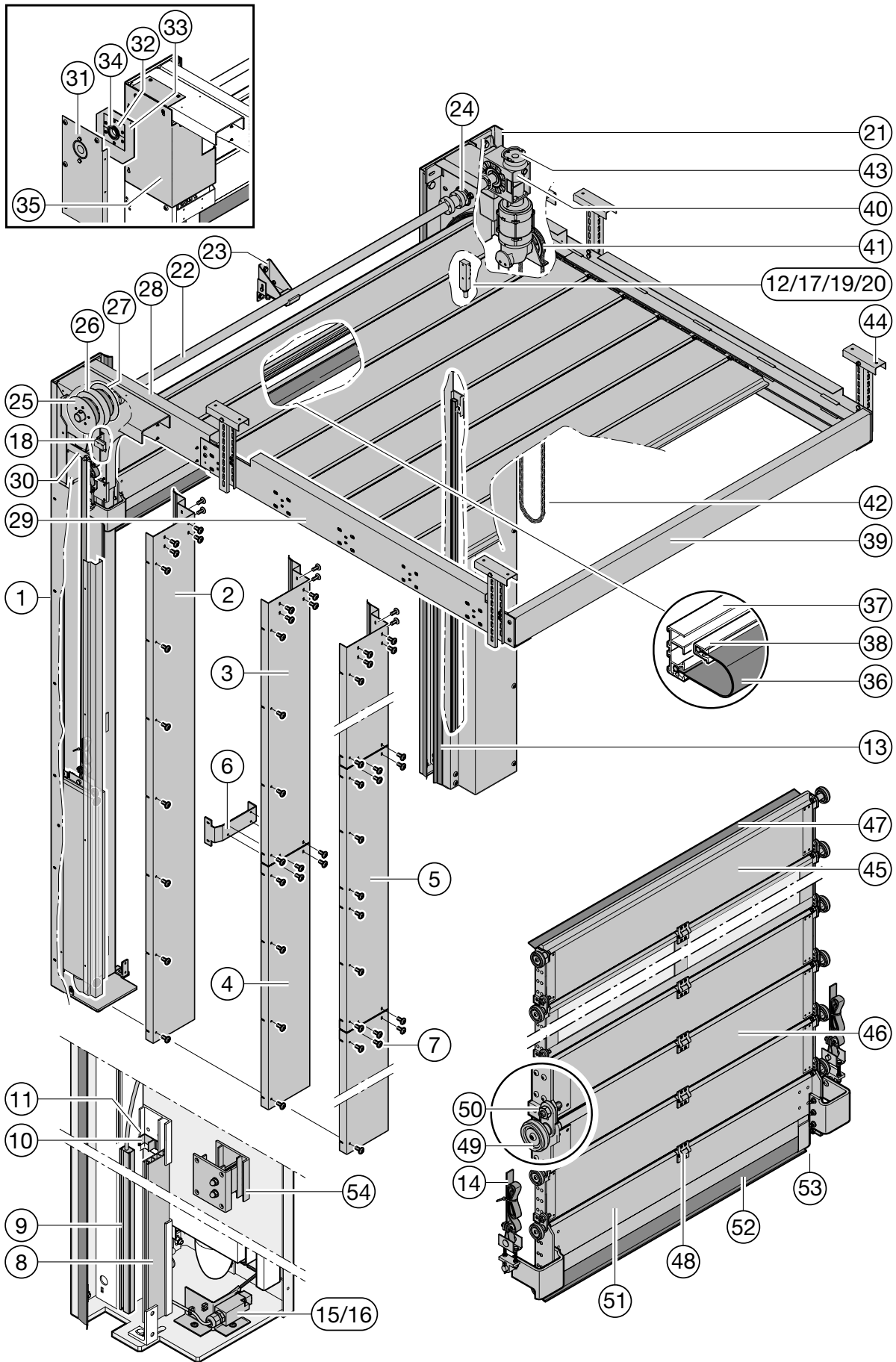

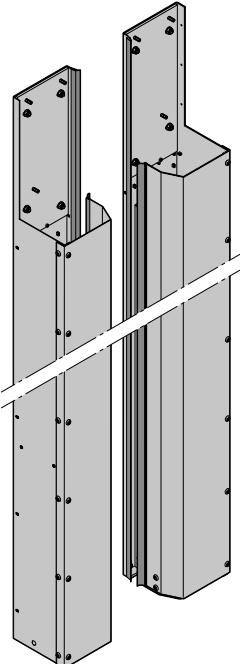
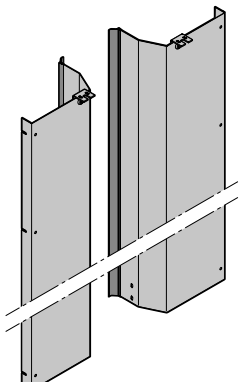
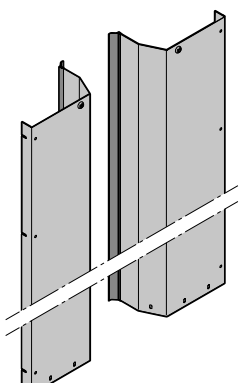

# 12. High-speed door HS 5015 Acoustic H

Article	Item	Description	Production period	Art. no.	Quantity	€
	*	<b>12.1 Side element</b>			Unit(s)	
		DE – DA < 6245 mm				
		Right	01.01.2016 –	4991852	_____	/ each
		Left	01.01.2016 –	4991853	_____	/ each
	*	<b>12.2 Cover, 1-part</b>			Unit(s)	
		DE – DA ≤ 3745 mm				
		Right	01.01.2016 – 31.12.2018	4981879	_____	/ m
			01.01.2019 –	4981881	_____	/ each
		Left	01.01.2016 – 31.12.2018	4981880	_____	/ m
			01.01.2019 –	4981882	_____	/ each
	*	<b>12.3 Top cover, 2-part</b>			Unit(s)	
		DE – DA > 3745 – ≤ 6245 mm				
		Right	01.01.2016 – 31.12.2018	4981883	_____	/ m
			01.01.2019 –	4981885	_____	/ each
		Left	01.01.2016 – 31.12.2018	4981884	_____	/ m
			01.01.2019 –	4981886	_____	/ each

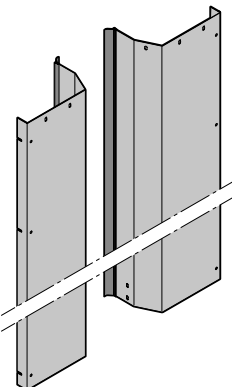
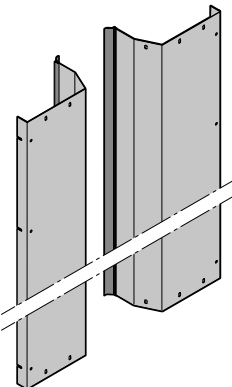
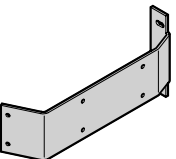

\* State purchase order number  
 Surcharge for high-quality wet coating panel (see page 173)  
 EN Ceiling height  
 DA Distance to ceiling

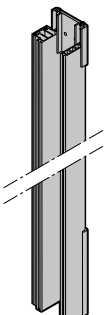
# 12. High-speed door HS 5015 Acoustic H

Article	Item	Description	Production period	Art. no.	Quantity	€
	*	<b>12.4 Bottom cover, 2-part</b>			Unit(s)	
		DE – DA > 3745 – ≤ 6245 mm Right	01.01.2016 –	4981887	_____	/ m
		Left	01.01.2016 –	4981888	_____	/ each / m / each
	*	<b>12.5 Centre cover, 3-part</b>			Unit(s)	
		DE – DA > 6245 mm Right	01.01.2016 –	4981889	_____	/ m
		Left	01.01.2016 –	4981890	_____	/ each / m / each
		<b>12.6 Cover bar</b>	01.01.2016 –	4991910	Unit(s) _____	/ each
 50x		<b>12.7 Self-tapping screws M6 x 12</b> Screws for cover		4992181	Unit(s) _____	/ each
	*	<b>12.8 Complete aluminium profile guide</b>			Unit(s)	
		Right	01.01.2016 –	4981364	_____	/ m
		Left	01.01.2016 –	4981365	_____	/ each / m / each



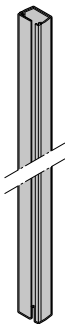
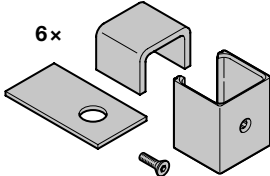
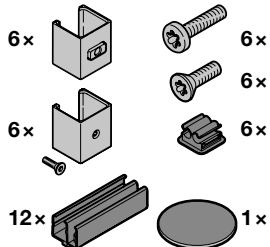

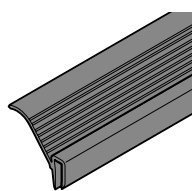
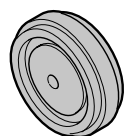
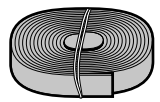
\* State purchase order number  
 Surcharge for high-quality wet coating panel (see page 173)  
 EN Ceiling height  
 DA Distance to ceiling

# 12. High-speed door HS 5015 Acoustic H

Article	Item	Description	Production period	Art. no.	Quantity	€
	*	<b>12.9 Light grille</b> For article numbers and lengths see pages 176 – 178 light grille / cable concept When replacing a light grille, vinyl foam adhesive tapes are also required.	01.01.2016 – 31.05.2021 01.06.2021 –		Unit(s) _____ _____	/each  /each
	6x	<b>12.10 Holder for light grille</b>	01.01.2017 – 31.05.2021	4981440	Unit(s) _____	/each
	6x 6x 12x 6x 6x 1x	<b>12.11 Light grille replacement accessories</b> From 01.06.2021 onwards, the bag is required when replacing the light grille.	01.06.2021 –	4982111	Unit(s) _____	/each
	*	<b>12.12 Snap cable, white, light grille</b> For article numbers and lengths see pages 176 – 178 light grille / cable concept	01.01.2016 –		Unit(s) _____	/each
	*	<b>12.13 Seal for guide</b> Additional 2 x per side element required  4000 mm 5000 mm 6000 mm	01.01.2016 – 01.01.2016 – 01.01.2016 –	4991585 4991586 4991490	Unit(s) _____ _____ _____	/each /each /each
		<b>12.14 Roller</b> For the counter weight	01.01.2016 –	159413	Unit(s) _____	/each
		<b>12.15 Flat belt 30 mm</b> For curtain and weight	01.01.2016 –	4991432	Unit(s) _____	/ m

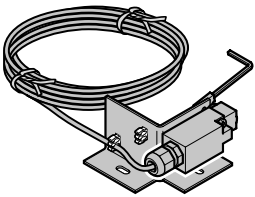
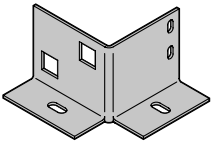

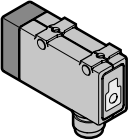
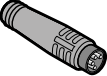
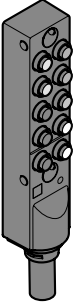
\* State purchase order number  
 Surcharge for high-quality wet coating panel (see page 173)  
 EN Ceiling height  
 DA Distance to ceiling

# 12. High-speed door HS 5015 Acoustic H

Article	Item Description	Production period	Art. no.	Quantity	€
	<b>12.16 Counter weight button with wiring snapM8</b>			Unit(s)	
	Right Left	01.01.2016 – 01.01.2016 –	4981665 4981666	_____ _____	/ each / each
	<b>12.17 Button support</b>			Unit(s)	
	Right Left	01.01.2016 – 01.01.2016 –	4981585 4981586	_____ _____	/ each / each
	* <b>12.18 Snap cable</b>			Unit(s)	
	blue, spring / counter weight yellow, belt monitoring For article numbers and lengths see pages 176 – 178 light grille / cable concept	01.01.2016 – 01.01.2016 –		_____ _____	/ each / each
	<b>12.19 Light button reflection</b>			Unit(s)	
	Discontinued articles The support bracket of the existing switch is not compatible with the new switch. You need the new support bracket (7992043, €9.60) to replace the switch. For curtain belt monitoring	01.01.2016 – 31.10.2024 01.11.2024 –	4991409 4982897	_____ _____	/ each / each
	<b>12.20 Bridge plug snap 8</b>	01.01.2016 –	4980188	Unit(s) _____	/ each
	* <b>12.21 Distributor 10 x M8 snap</b>			Unit(s)	
	For article numbers and lengths see pages 176 – 178 light grille / cable concept	01.01.2016 –		_____	/ each
	<b>12.22 Complete operator support bracket</b>	01.01.2016 –	4990800	Unit(s) _____	/ each

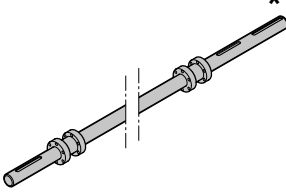
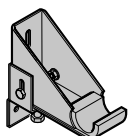
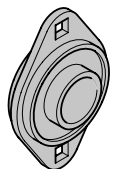
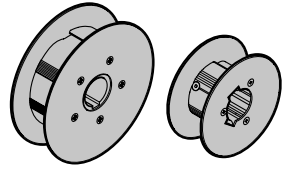
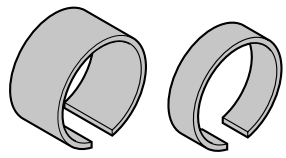

\* State purchase order number  
 Surcharge for high-quality wet coating panel (see page 173)  
 EN Ceiling height  
 DA Distance to ceiling

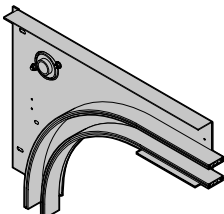
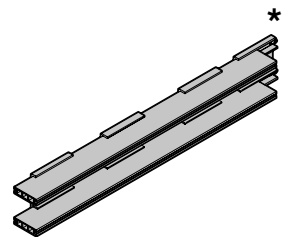
# 12. High-speed door HS 5015 Acoustic H

Article	Item Description	Production period	Art. no.	Quantity	€
	<b>12.23 Complete shaft</b>	01.01.2016 – 30.11.2018 01.12.2018 –	4992157 4981572	Unit(s) _____ _____	/ m / each / m / each
	<b>12.24 Shaft support</b>	01.01.2016 –	4990877	Unit(s) _____	/ each
	<b>12.25 Grooved ball-bearing ASPFL 208</b>	01.01.2016 –	159403	Unit(s) _____	/ each
	<b>12.26 Pulley</b> Ø 145 Ø 70	01.01.2016 – 01.01.2016 –	4991433 4991632	Unit(s) _____ _____	/ each / each
	<b>12.27 distance sleeve</b> 27 mm 30 mm 14 mm 12 mm	01.01.2016 – 30.11.2018 01.12.2018 – 01.01.2016 – 30.11.2018 01.12.2018 –	4991434 4991805 4991703 4981667	Unit(s) _____ _____ _____ _____	/ each / each / each / each
	<b>12.28 Adjusting ring</b>	01.01.2016 –	159163	Unit(s) _____	/ each
	<b>12.29 Complete support curve</b> Right Left	01.01.2016 – 01.01.2016 –	4992158 4992159	Unit(s) _____ _____	/ each / each
	<b>12.30 Complete horizontal guide</b> Right Left	01.01.2016 – 01.01.2016 –	4981366 4981367	Unit(s) _____ _____	/ m / m

\* State purchase order number  
 Surcharge for high-quality wet coating panel (see page 173)  
 EN Ceiling height  
 DA Distance to ceiling

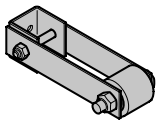
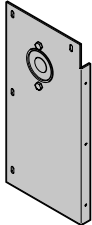
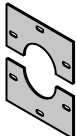
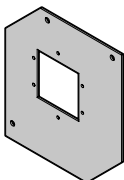
## 12. High-speed door HS 5015 Acoustic H

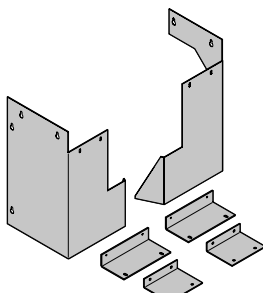
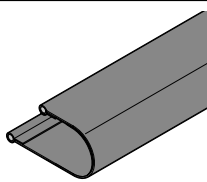
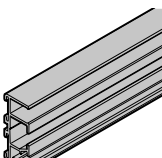
Article	Item Description	Production period	Art. no.	Quantity	€
	<b>12.31 Complete return pulley</b>	01.01.2016 –	4991214	Unit(s) _____	/ each
	<b>12.32 Complete cladding, bearing side</b>			Unit(s)	
	Right Left	01.01.2016 – 30.11.2018 01.01.2016 – 30.11.2018	4991189 4991188	_____ _____	/ each / each
	<b>12.33 Retaining plate for bearing</b> per door (2 units)	01.12.2018 –	4981284	Unit(s) _____	/ each
	<b>12.34 Sheet bearing</b>	01.12.2018 –	4981655	Unit(s) _____	/ each
	<b>12.35 Ball-bearing with groove</b>	01.12.2018 –	158993	Unit(s) _____	/ each
	<b>12.36 Cladding, complete</b>			Unit(s)	
		01.01.2016 – 30.11.2018 01.12.2018 –	4991492 4981660	_____ _____	/ each / each
	* <b>12.37 Curtain loop complete</b> 80, without ThermoFrame 100, with ThermoFrame	01.01.2016 – 01.01.2016 –	4991415 4991342	Unit(s) _____ _____	/ m / m
	* <b>12.38 Sealing frame channel</b> 4000 mm 5000 mm 6000 mm	01.01.2016 – 01.01.2016 – 01.01.2016 –	4991263 4991770 4991426	Unit(s) _____ _____ _____	/ each / each / each

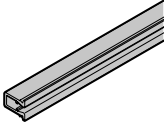
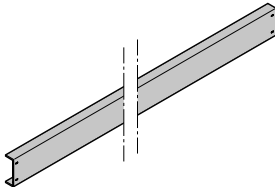
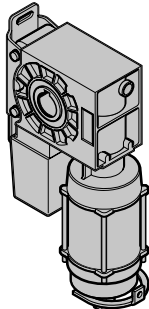
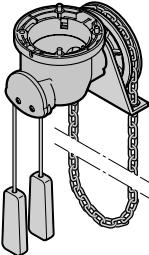
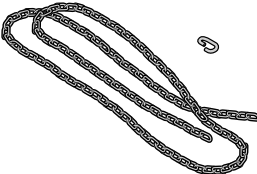
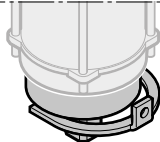

\* State purchase order number  
 Surcharge for high-quality wet coating panel (see page 173)  
 EN Ceiling height  
 DA Distance to ceiling

# 12. High-speed door HS 5015 Acoustic H

Article	Item Description	Production period	Art. no.	Quantity	€	
	<b>* 12.39 Sealing frame channel</b> 4000 mm 5000 mm 6000 mm	01.01.2016 – 01.01.2016 – 01.01.2016 –	4991264 4991771 4991427	Unit(s) _____ _____ _____	/ each / each / each	
		<b>* 12.40 Transverse cross strut</b> 01.01.2016 –	4981891	Unit(s) _____	/ m	
		<b>* 12.41 Operator</b>			Unit(s) _____	/ each
		<b>12.42 Emergency hand chain gearbox</b> 01.01.2016 –	158171	Unit(s) _____	/ each	
	<b>12.43 hand chain 10 m</b> With chain link	01.01.2016 –	4982733	Unit(s) _____	/ each	
	<b>12.44 Brake 11 Nm 24 V LH U</b> 01.01.2016 –	4982120	Unit(s) _____	/ each		

\* State purchase order number  
 Surcharge for high-quality wet coating panel (see page 173)  
 EN Ceiling height  
 DA Distance to ceiling

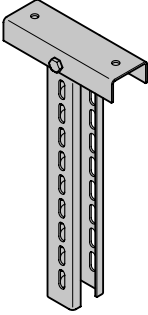
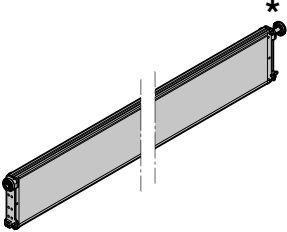
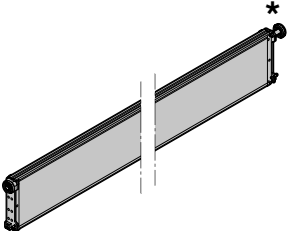
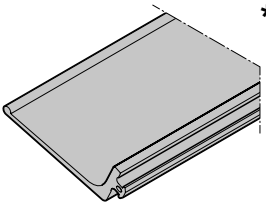
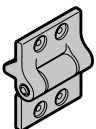
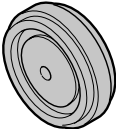
## 12. High-speed door HS 5015 Acoustic H

Article	Item Description	Production period	Art. no.	Quantity	€
	<b>12.45 Track suspension</b> Additionally required fixing material	01.01.2016 – 01.01.2016 –	4991282 4981415	Unit(s) _____ _____	/ each / each
	<b>12.46 Complete top panel</b> Standard version: RAL 9006  Section height: 225 mm	01.01.2016 –	4981368	Unit(s) _____	/ m / each
	<b>12.47 Inclination panel</b> Standard version: RAL 9006  Section height: 225 mm	01.01.2016 –	4981099	Unit(s) _____	/ m / each
	<b>12.48 Panel lintel seal</b>	01.01.2016 –	4991790	Unit(s) _____	/ m
	<b>12.49 Complete centre hinge</b> With screws  black Silver	01.01.2016 – 01.01.2016 –	4990838 4990797	Unit(s) _____ _____	/ each / each
	<b>12.50 Roller with band</b>  For the counter weight For panels	01.01.2016 – 01.01.2016 –	159413 4990818	Unit(s) _____ _____	/ each / each
	<b>12.51 Complete hinge connector</b>	01.01.2016 –	4981937	Unit(s) _____	/ each

\* State purchase order number

Surcharge for high-quality wet coating panel (see page 173)

EN Ceiling height

DA Distance to ceiling

# 12. High-speed door HS 5015 Acoustic H

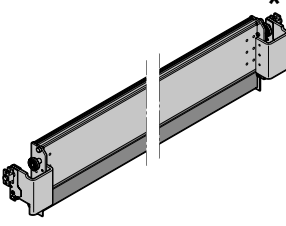
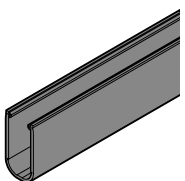
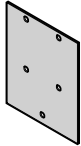
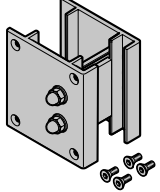
Article	Item Description	Production period	Art. no.	Quantity	€
	<b>12.52 Bottom part Complete</b>	01.01.2016 –	4991855	Unit(s) _____	/ m / each
	<b>12.53 Rubber profile Velcro strap</b> (additionally required: Velcro strap 1 m)	01.01.2016 – 01.03.2011 –	306843 159601	Unit(s) _____ _____	/ m / m
	<b>12.54 UPVC canopy</b>	01.01.2016 –	4991720	Unit(s) _____	/ each
	<b>12.55 Fixing clip</b> To hold the curtain in place when exchanging panels	01.01.2016 –	4990854	Unit(s) _____	/ each

\* State purchase order number  
 Surcharge for high-quality wet coating panel (see page 173)  
 EN Ceiling height  
 DA Distance to ceiling

# IsoSpeed Cold H 100

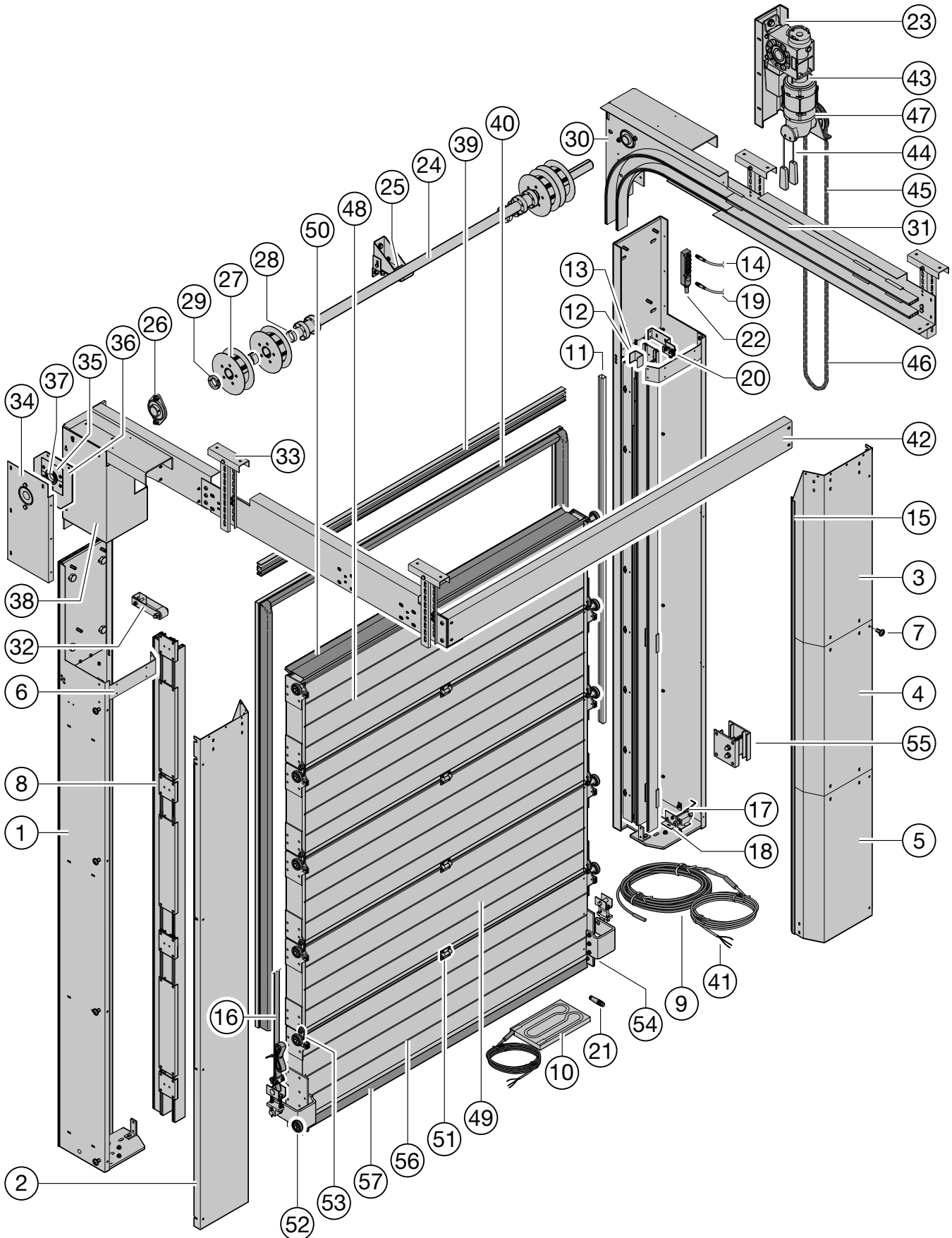

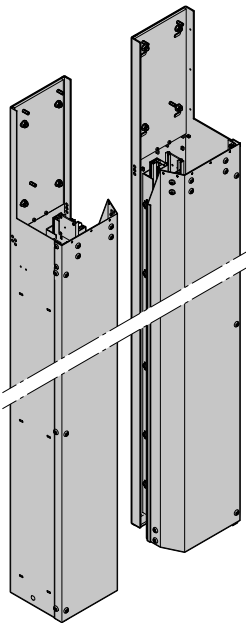
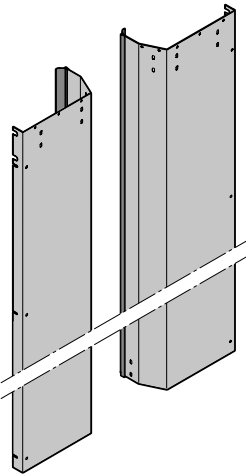
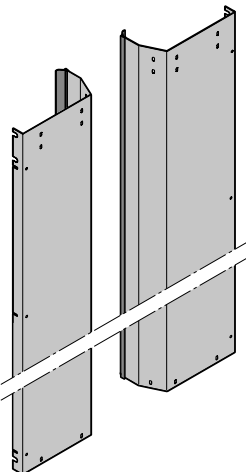

# 13. High-speed door IsoSpeed Cold H 100

Article	Item	Description	Production period	Art. no.	Quantity	€
	*	<b>13.1 Side element</b>			Unit(s)	
		Right	01.01.2016 –	4980602	_____	/ each
		Left	01.01.2016 –	4980603	_____	/ each
	*	<b>13.2 Cover, 1-part</b>			Unit(s)	
		LH ≤ 3745 mm				
		Right	01.01.2016 – 30.11.2018	4982903	_____	/ m
			01.12.2018 –	4981661	_____	/ each
	Left	01.01.2016 – 30.11.2018	4982904	_____	/ m	
			01.12.2018 –	4981662	_____	/ each
	*	<b>13.3 Top cover, 2-part</b>			Unit(s)	
		LH > 3745 mm				
		Right	01.01.2016 – 30.11.2018	4980605	_____	/ m
			01.12.2018 –	4982155	_____	/ each
	Left	01.01.2016 – 30.11.2018	4980609	_____	/ m	
			01.12.2018 –	4982156	_____	/ each

\* State purchase order number  
 Surcharge for high-quality wet coating panel (see page 173)

1) Not included as standard, only with deep freeze version  
 LH Track height

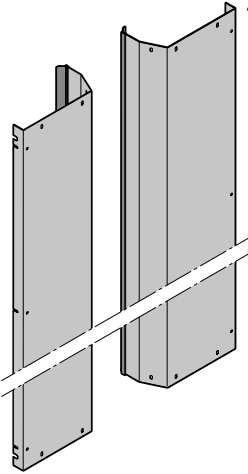
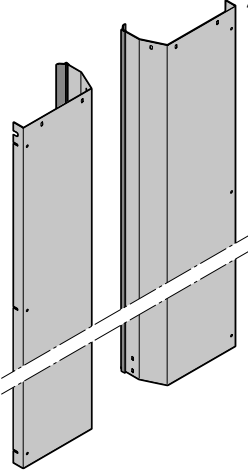
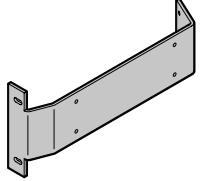
# 13. High-speed door IsoSpeed Cold H 100

Article	Item	Description	Production period	Art. no.	Quantity	€
	*	<b>13.4 Centre cover, 3-part</b>			Unit(s)	
		LH > 6245 mm Right	01.01.2016 –	4980607	_____	/ m / each
		Left	01.01.2016 –	4980611	_____	/ m / each
	*	<b>13.5 Bottom cover, 2-part</b>			Unit(s)	
		LH > 3745 mm Right	01.01.2016 –	4980606	_____	/ m / each
		Left	01.01.2016 –	4980633	_____	/ m / each
		<b>13.6 Cover bar</b>	01.01.2016 –	4980612	_____	/ each
 50x		<b>13.7 Self-tapping screws M6 x 12</b> Screws for cover		4992181	_____	/ each

- \* State purchase order number  
 Surcharge for high-quality wet coating panel (see page 173)
- 1) Not included as standard, only with deep freeze version  
 LH Track height

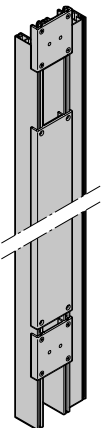
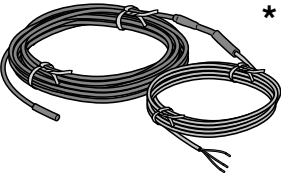
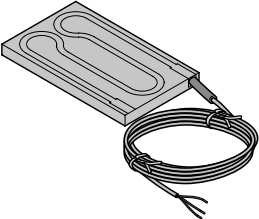
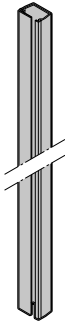
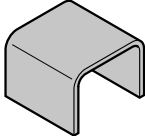
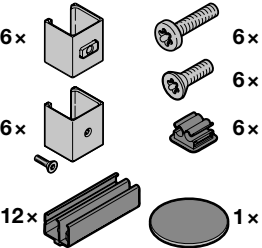

# 13. High-speed door IsoSpeed Cold H 100

Article	Item	Description	Production period	Art. no.	Quantity	€
	*	<b>13.8 Complete aluminium profile guide</b>			Unit(s)	
		Right	01.01.2016 –	4980350	_____	/ m
		Left	01.01.2016 –	4980349	_____	/ m
	*	<b>13.9 Side heating <sup>1)</sup></b>	01.01.2016 –	4981024	Unit(s) _____	/ m
		<b>13.10 Complete bottom plate heater <sup>1)</sup></b>			Unit(s)	
		Right Left	01.01.2016 – 01.01.2016 –	4980624 4980636	_____ _____	/ each / each
	*	<b>13.11 Light grille</b>  For article numbers and lengths see pages 176 – 178 light grille / cable concept When replacing a light grille, vinyl foam adhesive tapes are also required.	01.01.2016 – 31.05.2021 01.06.2021 –		Unit(s) _____ _____	/ each / each
		<b>13.12 Vinyl foam adhesive tape</b> Always 6 units per door	01.01.2016 – 31.05.2021	4980613	Unit(s) _____	/ each
		<b>13.13 Light grille replacement accessories</b> From 01.06.2021 onwards, the bag is required when replacing the light grille.	01.06.2021 –	4982111	Unit(s) _____	/ each

\* State purchase order number  
Surcharge for high-quality wet coating panel (see page 173)



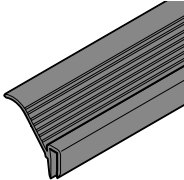
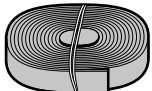
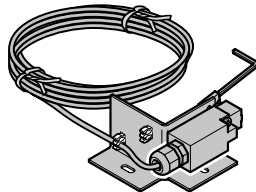
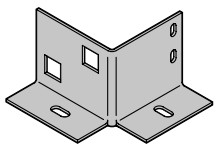

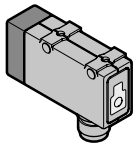
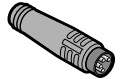

1) Not included as standard, only with deep freeze version  
LH Track height

# 13. High-speed door IsoSpeed Cold H 100

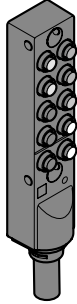
Article	Item	Description	Production period	Art. no.	Quantity	€
	*	<b>13.14 Snap cable, white, light grille</b> For article numbers and lengths see pages 176 – 178 light grille / cable concept	01.01.2016 –		Unit(s) _____	/ each
	*	<b>13.15 Seal for guide</b> Additional 2 × per side element required  4000 mm 5000 mm 6000 mm	01.01.2016 – 01.01.2016 – 01.01.2016 –	4991585 4991586 4991490	Unit(s) _____ _____ _____	/ each / each / each
		<b>13.16 Flat belt 30 mm</b>	01.01.2016 –	4991432	Unit(s) _____	/ m
		<b>13.17 Counter weight button with wiring snapM8</b>  Right Left	01.01.2016 – 01.01.2016 –	4981665 4981666	Unit(s) _____ _____	/ each / each
		<b>13.18 Button support</b>  Right Left	01.01.2016 – 01.01.2016 –	4981585 4981586	Unit(s) _____ _____	/ each / each
	*	<b>13.19 Snap cable</b>  blue, spring / counter weight yellow, belt monitoring For article numbers and lengths see pages 176 – 178 light grille / cable concept	01.01.2016 – 01.01.2016 –		Unit(s) _____ _____	/ each / each
		<b>13.20 Light button reflection</b>  Discontinued articles The support bracket of the existing switch is not compatible with the new switch. You need the new support bracket (7992043, €9.60) to replace the switch. For curtain belt monitoring	01.01.2016 – 31.10.2024  01.11.2024 –	4991409  4982897	Unit(s) _____ _____	/ each  / each
	*	<b>13.21 bridge plug</b>	01.01.2016 –	4980188	Unit(s) _____	/ each

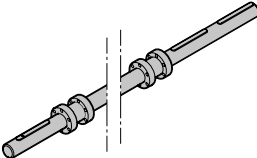
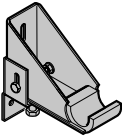

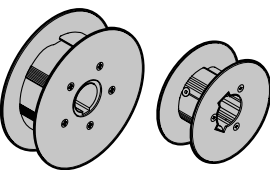
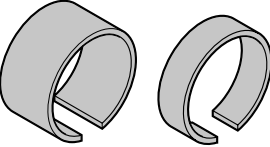

- \* State purchase order number  
Surcharge for high-quality wet coating panel (see page 173)  
1) Not included as standard, only with deep freeze version  
LH Track height

# 13. High-speed door IsoSpeed Cold H 100

Article	Item	Description	Production period	Art. no.	Quantity	€
	*	<b>13.22 Distributor 10 x M8 snap</b> For article numbers and lengths see pages 176 – 178 light grille / cable concept	01.01.2016 –		Unit(s) _____	/ each
		<b>13.23 Complete operator support bracket</b>	01.01.2016 –	4990800	Unit(s) _____	/ each
	*	<b>13.24 Operator shaft</b>	01.01.2016 – 30.11.2018 01.12.2018 –	4980614 4981745	Unit(s) _____ _____ _____ _____	/ m / each / m / each
		<b>13.25 Shaft support</b>	01.01.2016 –	4990877	Unit(s) _____	/ each
		<b>13.26 Grooved ball-bearing ASPFL 208</b>	01.01.2016 –	159403	Unit(s) _____	/ each
		<b>13.27 Pulley</b> Ø 145 Ø 70	01.01.2016 – 01.01.2016 –	4991433 4991632	Unit(s) _____ _____	/ each / each
		<b>13.28 distance sleeve</b> 27 mm 30 mm 14 mm 12 mm	01.01.2016 – 30.11.2018 01.12.2018 – 01.01.2016 – 30.11.2018 01.12.2018 –	4991434 4991805 4991438 4981667	Unit(s) _____ _____ _____ _____	/ each / each / each / each
		<b>13.29 Adjusting ring</b>	01.01.2016 –	159163	Unit(s) _____	/ each

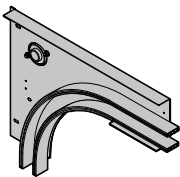
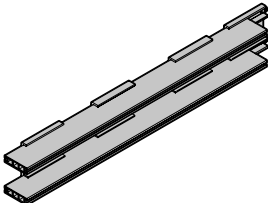
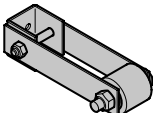
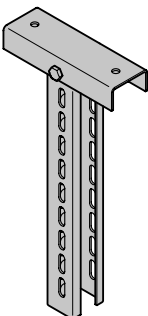
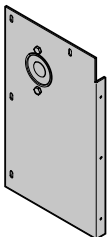

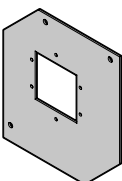
\* State purchase order number  
Surcharge for high-quality wet coating panel (see page 173)  
1) Not included as standard, only with deep freeze version  
LH Track height

# 13. High-speed door IsoSpeed Cold H 100

Article	Item	Description	Production period	Art. no.	Quantity	€
	*	<b>13.30 Complete support curve</b> Right Left	01.01.2016 – 01.01.2016 –	4981862 4981863	Unit(s) _____ _____	/ each / each
	*	<b>13.31 Complete horizontal guide</b> Right Left	01.01.2016 – 01.01.2016 –	4980617 4980618	Unit(s) _____ _____	/ m / m
		<b>13.32 Complete return pulley</b>	01.01.2016 –	4991214	Unit(s) _____	/ each
		<b>13.33 Track suspension</b> Additionally required fixing material	01.01.2016 – 01.01.2016 –	4991282 4981415	Unit(s) _____ _____	/ each / each
		<b>13.34 Complete cladding, bearing side</b> Right Left	01.01.2016 – 30.11.2018 01.01.2016 – 30.11.2018	4980621 4980620	Unit(s) _____ _____	/ each / each
		<b>13.35 Retaining plate for bearing</b> per door (2 units)	01.12.2018 –	4981284	Unit(s) _____	/ each
		<b>13.36 Sheet bearing</b>	01.12.2018 –	4981655	Unit(s) _____	/ each
		<b>13.37 Ball-bearing with groove</b>	01.12.2018 –	158993	Unit(s) _____	/ each

\* State purchase order number  
 Surcharge for high-quality wet coating panel (see page 173)  
 1) Not included as standard, only with deep freeze version  
 LH Track height

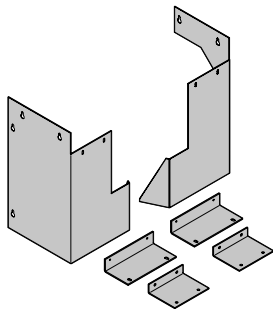
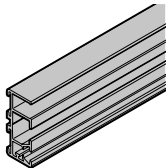
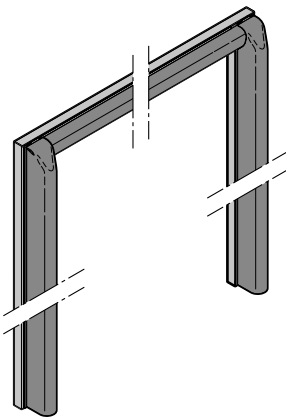

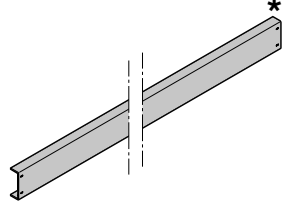
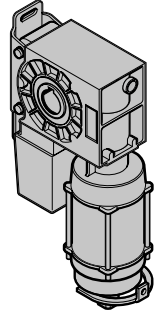
# 13. High-speed door IsoSpeed Cold H 100

Article	Item Description	Production period	Art. no.	Quantity	€
	<b>13.38 Cladding, complete</b>	01.12.2018 –	4981669	Unit(s) _____	/each
	<b>* 13.39 Sealing frame channel</b> 4000 mm 5000 mm 6000 mm	01.01.2016 – 01.01.2016 – 01.01.2016 –	4991263 4991770 4991426	Unit(s) _____ _____ _____	/each /each /each
	<b>13.40 Sealing frame 1)</b> Right Left Lintel	01.01.2016 – 01.01.2016 – 01.01.2016 –	4981039 4981038 4981040	Unit(s) _____ _____ _____	/ m / m / m
	<b>* 13.41 Sealing frame heater 1)</b>	01.01.2016 –	4980598	Unit(s) _____	/each
	<b>* 13.42 Transverse cross strut</b>	01.01.2016 –	4980619	Unit(s) _____	/each
	<b>* 13.43 Operator</b>			Unit(s) _____	/each

\* State purchase order number  
Surcharge for high-quality wet coating panel (see page 173)

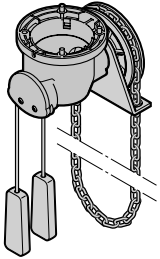
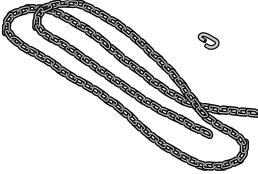

1) Not included as standard, only with deep freeze version  
LH Track height

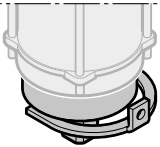
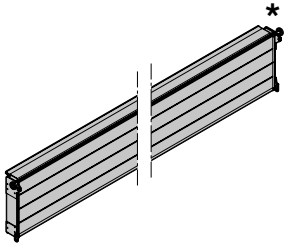
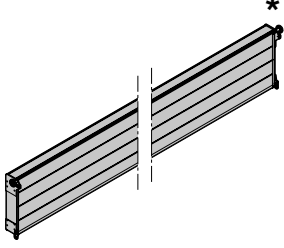
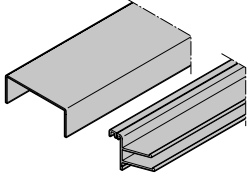
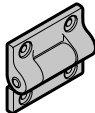
# 13. High-speed door IsoSpeed Cold H 100

Article	Item Description	Production period	Art. no.	Quantity	€
	<b>13.44 Emergency hand chain gearbox</b>	01.01.2016 –	158171	Unit(s) _____	/ each
	<b>13.45 hand chain 10 m</b> With chain link	01.01.2016 –	4982733	Unit(s) _____	/ each
	<b>13.46 Hand chain link</b>	01.01.2016 –	306407	Unit(s) _____	/ each
	<b>13.47 Brake 11 Nm + 24 V</b>	01.01.2016 –	4982120	Unit(s) _____	/ each
	<b>13.48 Top panel 500 mm, complete</b> Standard version: RAL 9002	01.01.2016 –	4980622	Unit(s) _____	/ m / each
	<b>13.49 Complete PU panel 500 mm</b> Standard version: RAL 9002	01.01.2016 –	4980348	Unit(s) _____	/ m / each
	<b>13.50 Seal L 6000 mm</b>	01.01.2016 –	4981677	Unit(s) _____	/ each
	<b>U-profile L 6000 mm</b> (top panel < 500 mm)	01.01.2016 –	4981678	Unit(s) _____	/ each
	<b>13.51 Complete centre hinge</b> With screws			Unit(s) _____	
	black Silver	01.01.2016 – 01.01.2016 –	4991905 4991904	Unit(s) _____ _____	/ each / each

- \* State purchase order number  
Surcharge for high-quality wet coating panel (see page 173)
- 1) Not included as standard, only with deep freeze version
- LH Track height

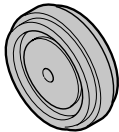
# 13. High-speed door IsoSpeed Cold H 100

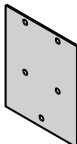
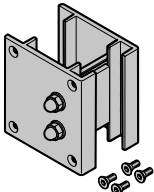
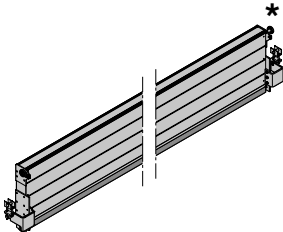
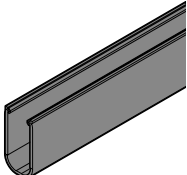
Article	Item Description	Production period	Art. no.	Quantity	€
	<b>13.52 Roller with band</b> For the counter weight For panels	01.01.2016 – 01.01.2016 –	159413 4990818	Unit(s) _____ _____	/ each / each
	<b>13.53 Complete hinge connector</b>	01.01.2016 –	4981937	Unit(s) _____	/ each
	<b>13.54 UPVC canopy</b>	01.01.2016 –	4992175	Unit(s) _____	/ each
	<b>13.55 Fixing clip</b> To hold the curtain in place when exchanging panels	01.01.2016 –	4990854	Unit(s) _____	/ each
	<b>13.56 Bottom part</b> Complete	01.01.2016 –	4980347	Unit(s) _____	/ m / each
	<b>13.57 Rubber profile</b> <b>Velcro strap</b> (additionally required: Velcro strap 1 m)	01.01.2016 – 01.03.2011 –	4980601 159601	Unit(s) _____ _____	/ m / m

- \* State purchase order number
- Surcharge for high-quality wet coating panel (see page 173)
- 1) Not included as standard, only with deep freeze version
- LH Track height

# IsoSpeed Cold V 100

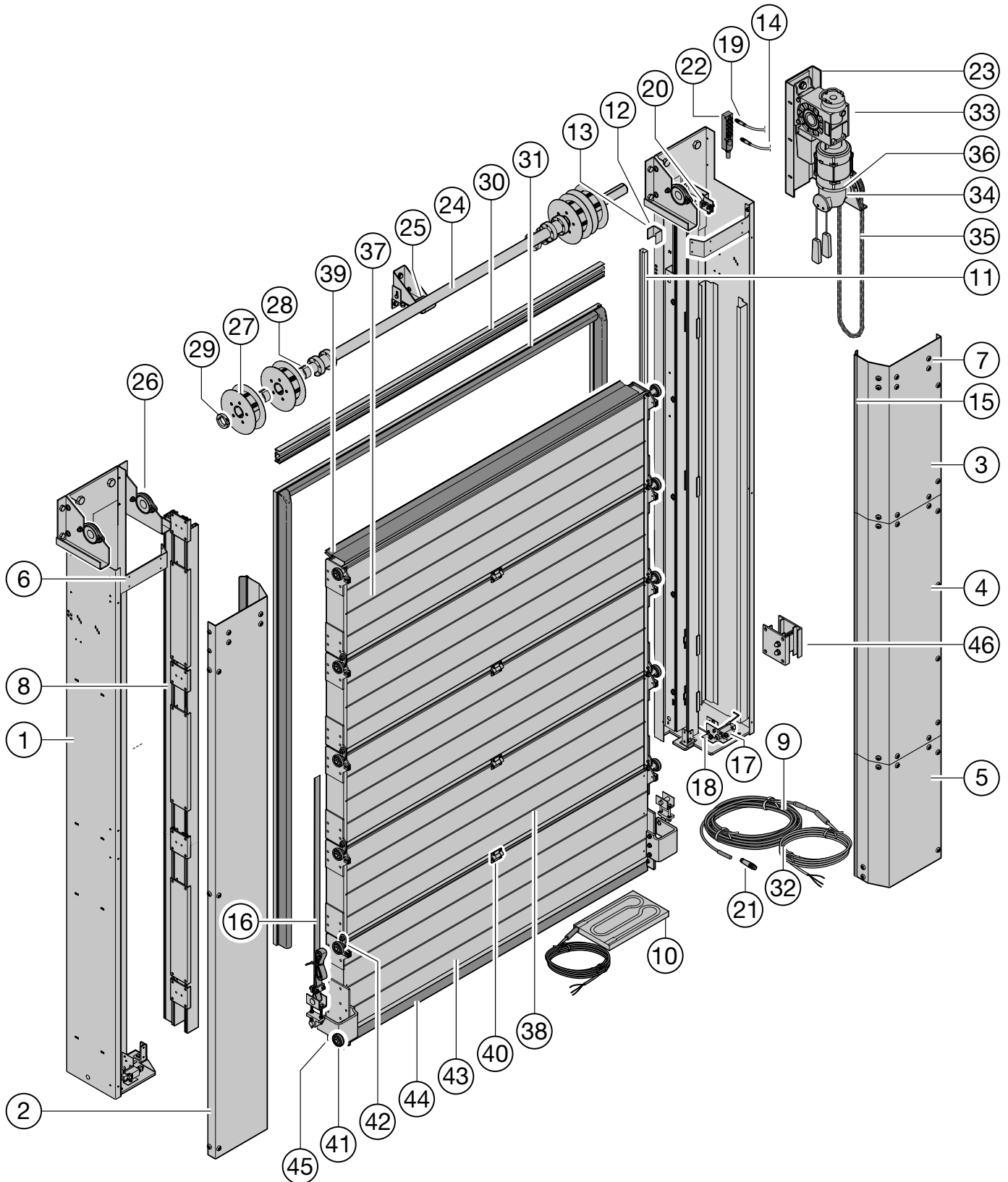

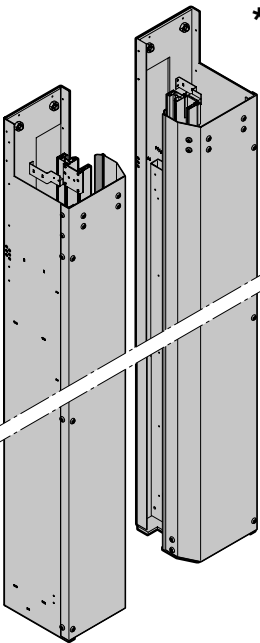
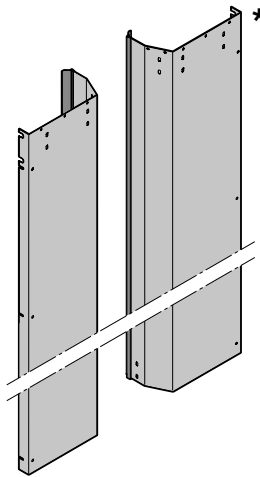
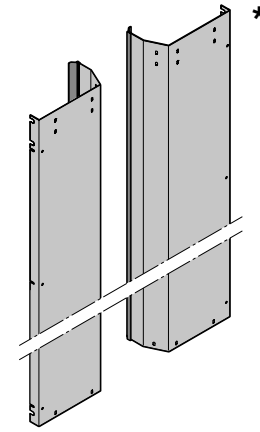

# 14. High-speed door IsoSpeed Cold V 100

Article	Item	Description	Production period	Art. no.	Quantity	€
	*	<b>14.1 Side element</b>			Unit(s)	
		Right	01.01.2016 –	4980625	_____	/ each
		Left	01.01.2016 –	4980626	_____	/ each
	*	<b>14.2 Cover, 1-part</b>			Unit(s)	
		LDH ≤ – 2000 mm				
		Right	01.01.2016 –	4980627	_____	/ m
		Left	01.01.2016 –	4980631	_____	/ m
						/ each
	*	<b>14.3 Top cover, 2-part</b>			Unit(s)	
		LDH ≥ – 2000 mm				
		Right	01.01.2016 –	4980628	_____	/ m
		Left	01.01.2016 –	4980632	_____	/ m
						/ each

- \* State purchase order number
- Surcharge for high-quality wet coating panel (see page 173)
- 1) Not included as standard, only with deep freeze version

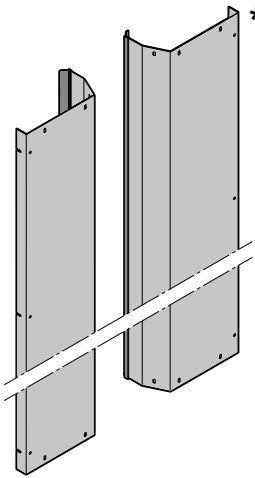
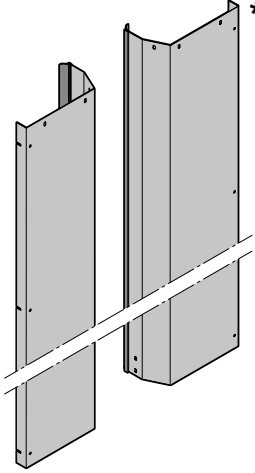
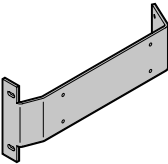
# 14. High-speed door IsoSpeed Cold V 100

Article	Item	Description	Production period	Art. no.	Quantity	€
	*	<b>14.4 Centre cover, 3-part</b>			Unit(s)	
		LDH ≥ – 3000 mm				
		Right	01.01.2016 –	4980630	_____	/ m
		Left	01.01.2016 –	4980634	_____	/ each / m / each
	*	<b>14.5 Bottom cover, 2-part</b>			Unit(s)	
		LDH ≥ – 2000 mm				
		Right	01.01.2016 –	4980629	_____	/ m
		Left	01.01.2016 –	4980633	_____	/ each / m / each
		<b>14.6 Cover bar</b>	01.01.2016 –	4980612	Unit(s) _____	/ each
 50x		<b>14.7 Self-tapping screws M6 x 12</b> Screws for cover		4992181	Unit(s) _____	/ each

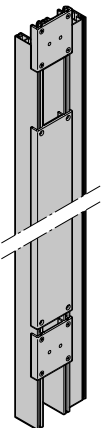
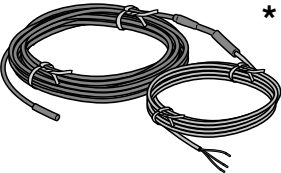
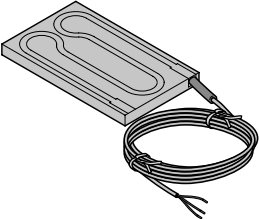
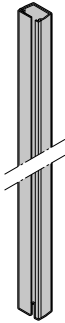
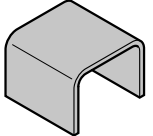
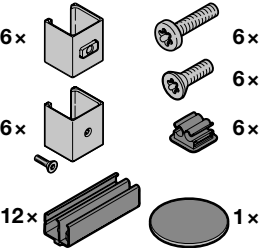

- \* State purchase order number  
 Surcharge for high-quality wet coating panel (see page 173)  
 1) Not included as standard, only with deep freeze version

# 14. High-speed door IsoSpeed Cold V 100

Article	Item	Description	Production period	Art. no.	Quantity	€
	*	<b>14.8 Complete aluminium profile guide</b>			Unit(s)	
		Right	01.01.2016 –	4980346	_____	/ m
		Left	01.01.2016 –	4980345	_____	/ m
	*	<b>14.9 Side heating <sup>1)</sup></b>	01.01.2016 –	4980599	Unit(s) _____	/ m
		<b>14.10 Complete bottom plate heater <sup>1)</sup></b>			Unit(s)	
		Right Left	01.01.2016 – 01.01.2016 –	4980624 4980636	_____ _____	/ each / each
	*	<b>14.11 Light grille</b>  For article numbers and lengths, see pages 176 – 178 light grille –/ – cable concept When replacing a light grille, vinyl foam adhesive tapes are also required.	01.01.2016 – 31.05.2021 01.06.2021 –		Unit(s) _____ _____	/ each / each
		<b>14.12 Vinyl foam adhesive tape</b> Always 6 units per door	01.01.2016 – 31.05.2021	4980613	Unit(s) _____	/ each
		<b>14.13 Light grille replacement accessories</b> From 01.06.2021 onwards, the bag is required when replacing the light grille.	01.06.2021 –	4982111	Unit(s) _____	/ each



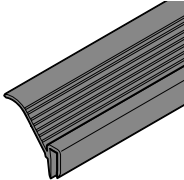
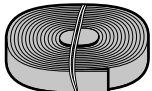
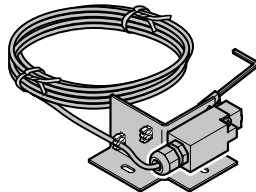
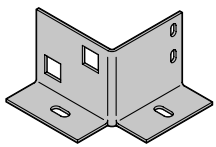

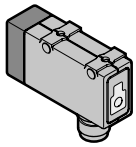
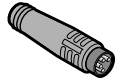

\* State purchase order number  
 Surcharge for high-quality wet coating panel (see page 173)  
 1) Not included as standard, only with deep freeze version

# 14. High-speed door IsoSpeed Cold V 100

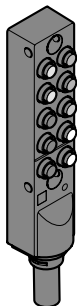
Article	Item	Description	Production period	Art. no.	Quantity	€
	*	<b>14.14 Snap cable, white, light grille</b> For article numbers and lengths see pages 176 – 178 light grille / cable concept	01.01.2016 –		Unit(s) _____	/ each
	*	<b>14.15 Seal for guide</b> Additional 2 × per side element required  4000 mm 5000 mm 6000 mm	01.01.2016 – 01.01.2016 – 01.01.2016 –	4991585 4991586 4991490	Unit(s) _____ _____ _____	/ each / each / each
		<b>14.16 Flat belt 30 mm</b>	01.01.2016 –	4991432	Unit(s) _____	/ m
		<b>14.17 Counter weight button with wiring snapM8</b>  Right Left	01.01.2016 – 01.01.2016 –	4981665 4981666	Unit(s) _____ _____	/ each / each
		<b>14.18 Button support</b>  Right Right	01.01.2016 – 01.01.2016 –	4981585 4981586	Unit(s) _____ _____	/ each / each
	*	<b>14.19 Snap cable</b>  blue, spring / counter weight yellow, belt monitoring For article numbers and lengths see pages 176 – 178 light grille / cable concept	01.01.2016 – 01.01.2016 –		Unit(s) _____ _____	/ each / each
		<b>14.20 Light button reflection</b>  Discontinued articles The support bracket of the existing switch is not compatible with the new switch. You need the new support bracket (7992042, €9.60) to replace the switch. For curtain belt monitoring	01.01.2016 – 31.10.2024  01.11.2024 –	4991409  4982897	Unit(s) _____ _____	/ each / each
	*	<b>14.21 bridge plug</b>	01.01.2016 –	4980188	Unit(s) _____	/ each

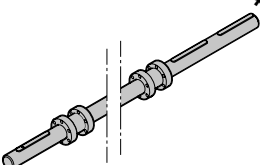
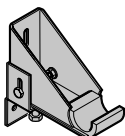
- \* State purchase order number  
Surcharge for high-quality wet coating panel (see page 173)  
1) Not included as standard, only with deep freeze version

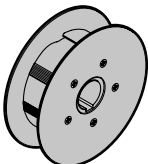
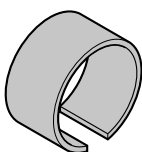
# 14. High-speed door IsoSpeed Cold V 100

Article	Item	Description	Production period	Art. no.	Quantity	€
	*	<b>14.22 Distributor 10 x M8 snap</b> For article numbers and lengths see pages 176 – 178 light grille / cable concept	01.01.2016 –		Unit(s) _____	/ each
		<b>14.23 Complete operator support bracket</b>	01.01.2016 –	4990800	Unit(s) _____	/ each
	*	<b>14.24 Operator shaft</b>	01.01.2016 – 30.11.2018 01.12.2018 –	4992209 4981530	Unit(s) _____ _____	/ m / each / m / each
		<b>14.25 Shaft support</b>	01.01.2016 –	4990877	Unit(s) _____	/ each
		<b>14.26 Grooved ball-bearing ASPFL 208</b>	01.01.2016 –	159403	Unit(s) _____	/ each
		<b>14.27 Pulley</b> Ø 145	01.01.2016 –	4991433	Unit(s) _____	/ each
		<b>14.28 distance sleeve</b> 30 mm 12 mm	01.01.2016 – 01.12.2018 –	4991805 4981667	Unit(s) _____ _____	/ each / each
		<b>14.29 Adjusting ring</b>	01.01.2016 –	159163	Unit(s) _____	/ each

- \* State purchase order number  
Surcharge for high-quality wet coating panel (see page 173)  
1) Not included as standard, only with deep freeze version

# 14. High-speed door IsoSpeed Cold V 100

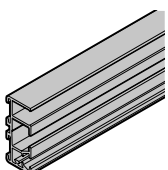
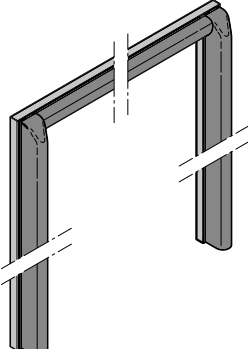
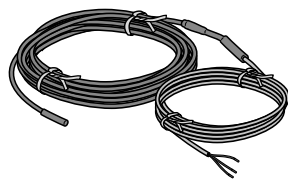
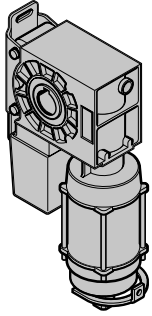
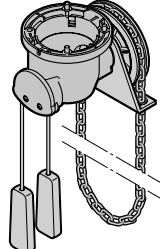
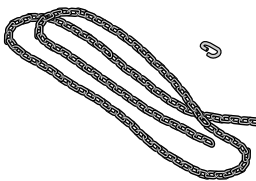
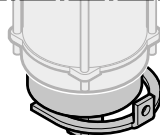

Article	Item	Description	Production period	Art. no.	Quantity	€
	*	<b>14.30 Sealing frame channel</b>			Unit(s)	
		4000 mm	01.01.2016 –	4991263	_____	/ each
		5000 mm	01.01.2016 –	4991770	_____	/ each
		6000 mm	01.01.2016 –	4991426	_____	/ each
		<b>14.31 Sealing frame <sup>1)</sup></b>			Unit(s)	
		Right	01.01.2016 –	4981039	_____	/ m
		Left	01.01.2016 –	4981038	_____	/ m
		Lintel	01.01.2016 –	4981040	_____	/ m
		<b>14.32 Sealing frame heater <sup>1)</sup></b>	01.01.2016 –	4980598	_____	/ each
	*	<b>14.33 Operator</b>			Unit(s)	/ each
		<b>14.34 Emergency hand chain gearbox</b>	01.01.2016 –	158171	_____	/ each
		<b>14.35 hand chain 10 m</b> With chain link	01.01.2016 –	4982733	_____	/ each
		<b>14.36 Brake 11 Nm + 24 V</b>	01.01.2016 –	4982120	_____	/ each

\* State purchase order number

Surcharge for high-quality wet coating panel (see page 173)

1) Not included as standard, only with deep freeze version

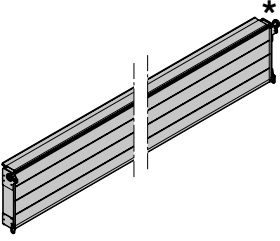
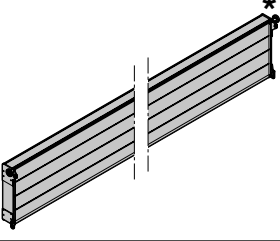
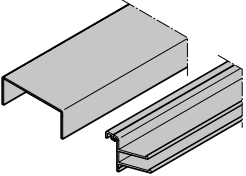
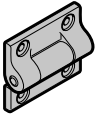
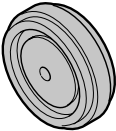
# 14. High-speed door IsoSpeed Cold V 100

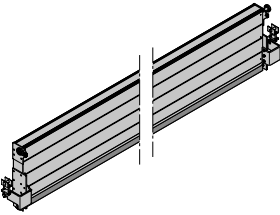
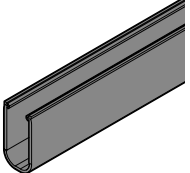
Article	Item Description	Production period	Art. no.	Quantity	€
	<b>14.37 Top panel 500 mm, complete</b> Standard version: RAL 9002	01.01.2016 –	4980622	Unit(s) _____	/ m / each
	<b>14.38 Complete PU panel 500 mm</b> Standard version: RAL 9002	01.01.2016 –	4980348	Unit(s) _____	/ m / each
	<b>14.39 Seal L 6000 mm</b> <b>U-profile L 6000 mm</b> (top panel < 500 mm)	01.01.2016 – 01.01.2016 –	4981677 4981678	Unit(s) _____ _____	/ each / each
	<b>14.40 Complete centre hinge</b> With screws  black Silver	01.01.2016 – 01.01.2016 –	4991905 4991904	Unit(s) _____ _____	/ each / each
	<b>14.41 Roller with band</b>  For the counter weight For panels	01.01.2016 – 01.01.2016 –	159413 4990818	Unit(s) _____ _____	/ each / each
	<b>14.42 Complete hinge connector</b>	01.01.2016 –	4981937	Unit(s) _____	/ each
	<b>14.43 Bottom part Complete</b> Standard version: RAL 9002	01.01.2016 –	4980347	Unit(s) _____	/ m / each
	<b>14.44 Rubber profile Velcro strap</b> (additionally required: Velcro strap 1 m)	01.01.2016 – 01.03.2011 –	4980601 159601	Unit(s) _____ _____	/ m / m

- \* State purchase order number  
Surcharge for high-quality wet coating panel (see page 173)  
1) Not included as standard, only with deep freeze version

# 14. High-speed door IsoSpeed Cold V 100

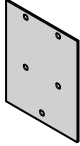
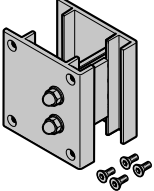
Article	Item Description	Production period	Art. no.	Quantity	€
	<b>14.45 UPVC canopy</b>	01.01.2016 –	4992175	Unit(s) _____	/ each
	<b>14.46 Fixing clip</b> To hold the curtain in place when exchanging panels	01.01.2016 –	4990854	Unit(s) _____	/ each





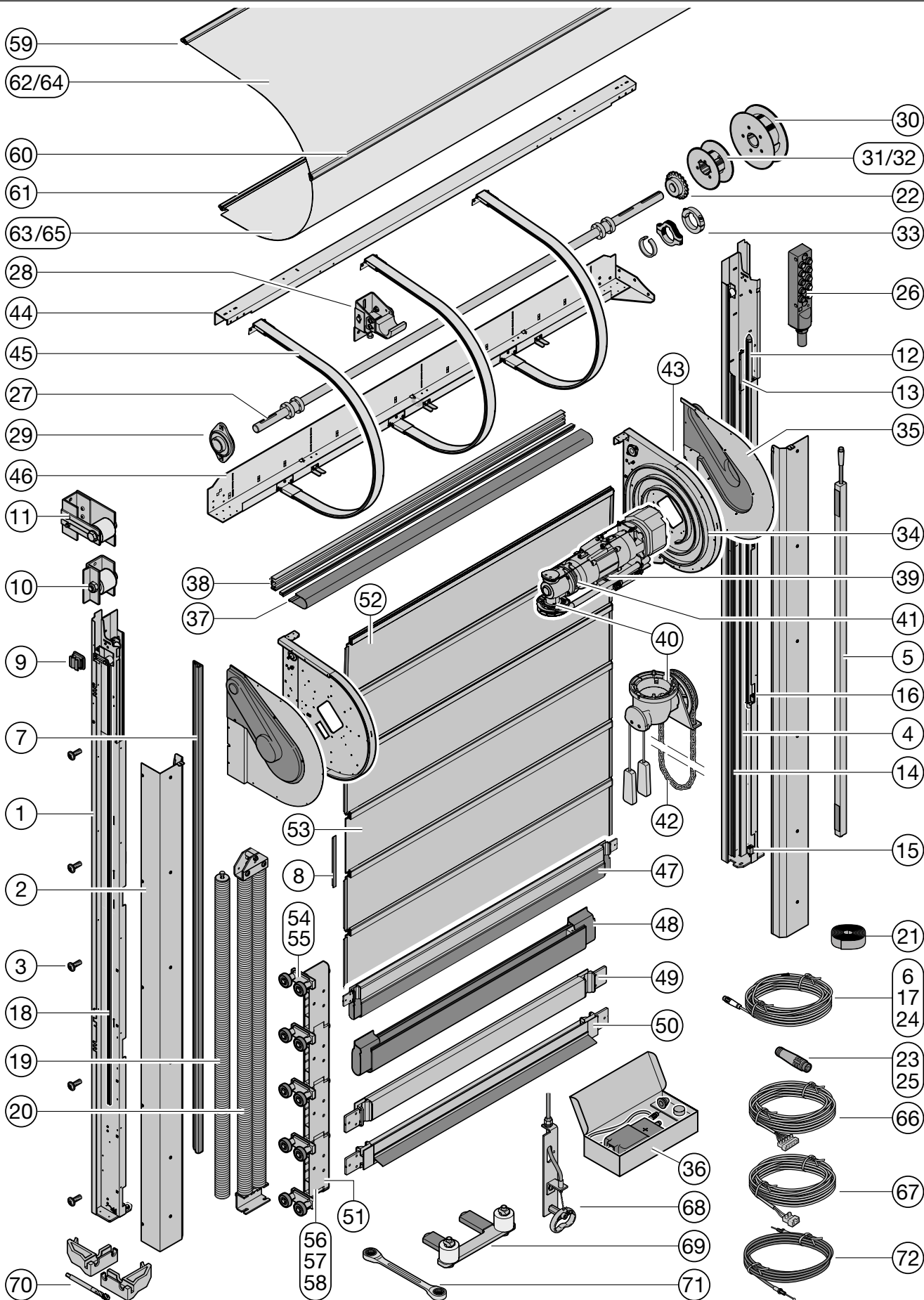

- \* State purchase order number  
 Surcharge for high-quality wet coating panel (see page 173)
- 1) Not included as standard, only with deep freeze version

# HS 5040 TurboLux (S)

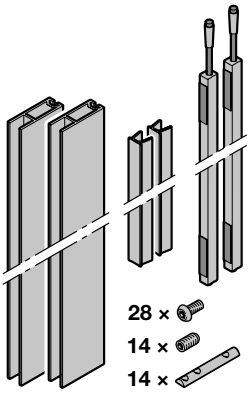

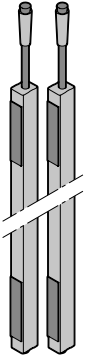
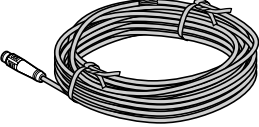

# 15. High-speed door HS 5040 TurboLux (S)

Article	Item Description	Production period	Art. no.	Quantity	€
 <p>28 x  14 x  14 x </p>	<p><b>15.4 Guide profile</b> Light grille depending on LDH</p>	01.06.2022 –	4982741	Unit(s) _____	<b>1540,00 /each</b>
	<p><b>15.5 Light grille</b> with adhesive tape</p>	01.06.2022 –	4982742	Unit(s) _____	<b>1122,00 /each</b>
	<p><b>15.6 Snap cable, light grille</b> For article numbers and lengths see pages 176 – 178 light grille / cable concept</p>	01.06.2022 –		Unit(s) _____	<b>37,00 /each</b>
	<p><b>15.7 Edge guard</b></p>	01.06.2022 –	157563	m _____	<b>20,60 / m</b>
	<p><b>15.8 Edge guard</b> L = 100 mm L = 250 mm L = 400 mm L = 550 mm</p>	01.06.2025 – 01.06.2025 – 01.06.2025 – 01.06.2022 –	7992747 7992746 7992745 4982818	Unit(s) _____ _____ _____ _____	<b>2,10 /each</b> <b>5,20 /each</b> <b>9,30 /each</b> <b>12,30 /each</b>



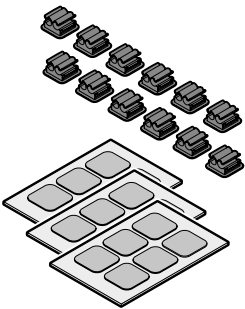
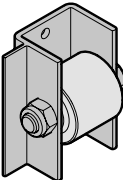
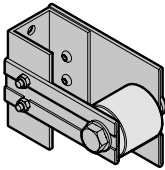
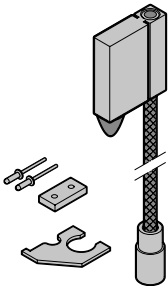
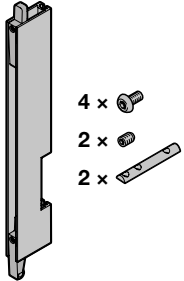
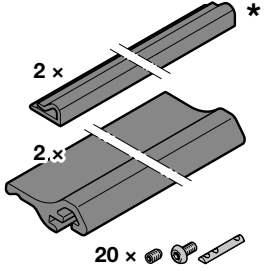

\* State purchase order number

# 15. High-speed door HS 5040 TurboLux (S)

Article	Item	Description	Production period	Art. no.	Quantity	€
	15.9	Cable clips	01.06.2022 –	4982743	Unit(s) _____	20,00 / each
	15.10	Return pulley for door leaf, complete	01.06.2022 –	4982744	Unit(s) _____	32,00 / each
	15.11	Return pulley for spring / counter weight complete	01.06.2022 –	4982745	Unit(s) _____	39,00 / each
	15.12	Start-up device complete LDH ≤ 2900 mm – 1115 mm LDH > 2900 mm – 1660 mm	01.06.2022 – 31.03.2024 01.04.2024 – 01.06.2022 – 31.03.2024 01.04.2024 –	4982746 7992316 4982646 7992317	Unit(s) _____ _____ _____ _____	147,00 / each 147,00 / each 156,00 / each 156,00 / each
	15.13	Connection profile boom, complete 4 x _____ 2 x _____ 2 x _____	01.06.2022 –	4982748	Unit(s) _____	52,00 / each
	15.14	Wind strip, complete 2 x _____ 2 x _____ 20 x _____	01.06.2022 –	4982749	m _____	116,00 / m

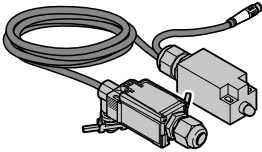
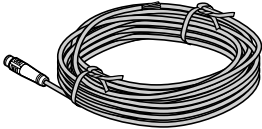
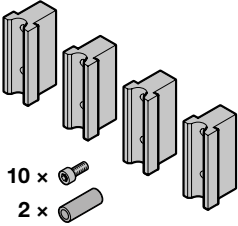
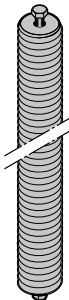

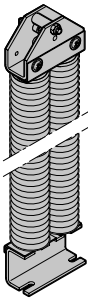

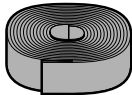
\* State purchase order number

# 15. High-speed door HS 5040 TurboLux (S)

Article	Item Description	Production period	Art. no.	Quantity	€
	<b>15.15 Button wired spring / counter weight and start-up system, complete</b>  Right Left	01.06.2022 – 01.06.2022 –	4982848 4982849	Unit(s) _____ _____	 <b>247,00 / each</b> <b>247,00 / each</b>
	<b>15.16 Button with wiring</b> For start-up system, complete	01.06.2022 –	4982819	Unit(s) _____	<b>156,00 / each</b>
	* <b>15.17 Snap cable, blue, spring / counter weight</b> For article numbers and lengths see pages 176 – 178 light grille / cable concept	01.06.2022 –		Unit(s) _____	<b>37,00 / each</b>
	<b>15.18 Complete glider</b>	01.06.2022 –	4982647	Unit(s) _____	<b>45,00 / each</b>
	* <b>15.19 Single spring complete</b> <b>L = 1040 mm – 2450 mm</b> <b>Note:</b> Always replace all individual springs of a complete package.	01.06.2022 –		Unit(s) _____	 / each
	* <b>15.20 Complete spring assembly</b> <b>L = 1040 mm – 2450 mm</b>  Right Left	01.06.2022 – 01.06.2022 –	7992641 7992642	Unit(s) _____ _____	 / each  / each
	<b>15.21 Belt 30 mm</b>	01.06.2022 –	4991432	m _____	<b>45,00 / m.</b>

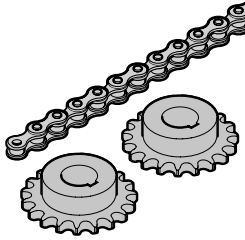
\* State purchase order number

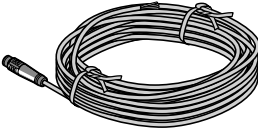
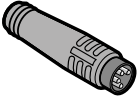
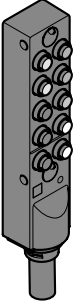
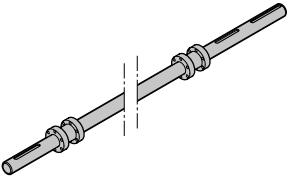
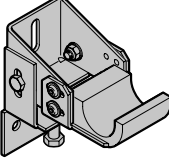
# 15. High-speed door HS 5040 TurboLux (S)

Article	Item Description	Production period	Art. no.	Quantity	€
	<p><b>* 15.22 Set: Reinforced roller chain</b></p> <p>L = 1466 mm L = 1410 mm, LDH ≤ 3600 mm</p> <p><b>Note:</b> From 01.06.2022 – 01.06.2025 the LDH value is irrelevant.</p>	01.06.2022 – 01.06.2025 –	4982751 7992658	Unit(s) _____ _____	<b>97,00 / each</b> <b>97,00 / each</b>
	<b>15.23 Terminating bridge plug 120 Ohm</b>	01.06.2022 –	4981403	Unit(s) _____	<b>11,90 / each</b>
	<p><b>15.24 Multiturn cable</b></p> <p>Lengths [mm]</p>			Unit(s)	
	3500	01.06.2022 –	4982188	_____	<b>61,00 / each</b>
	6500	01.06.2022 –	4982189	_____	<b>61,00 / each</b>
	10500	01.06.2022 –	4982190	_____	<b>61,00 / each</b>
	15500	01.06.2022 –	4982191	_____	<b>61,00 / each</b>
	20500	01.06.2022 –	4982192	_____	<b>61,00 / each</b>
	<b>15.25 Bridge plug M8 snap</b>	01.06.2022 –	4980188	Unit(s) _____	<b>16,40 / each</b>
	<p><b>* 15.26 Distributor 10 x M8 snap</b></p> <p>For article numbers and lengths see pages 176 – 178 light grille / cable concept</p>	01.06.2022 –		Unit(s) _____	<b>241,00 / each</b>
	<b>15.27 Complete shaft</b>	01.06.2022 –	4982752	Unit(s) _____	<b>77,00 / m</b> <b>515,00 / each</b>
	<b>15.28 Shaft support</b>	01.06.2022 –	4982753	Unit(s) _____	<b>72,00 / each</b>
	<b>15.29 Grooved ball-bearing ASPFL 208</b>	01.06.2022 –	159403	Unit(s) _____	<b>89,00 / each</b>

\* State purchase order number

# 15. High-speed door HS 5040 TurboLux (S)

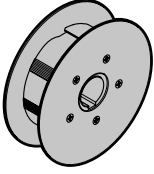
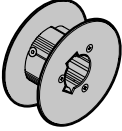
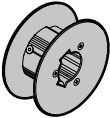
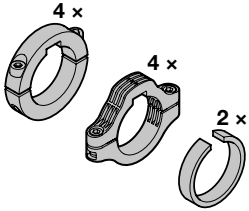
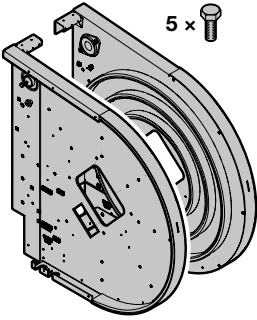
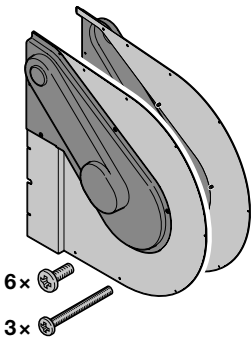
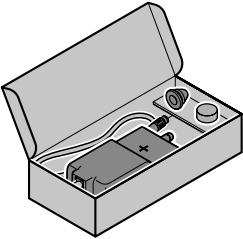
Article	Item Description	Production period	Art. no.	Quantity	€
	<b>15.30 Guide roller Ø 145 mm</b>	01.06.2022 –	4991433	Unit(s) _____	<b>93,00 /each</b>
	<b>15.31 Guide roller Ø 70 mm</b>	01.06.2022 –	4991632	Unit(s) _____	<b>70,00 /each</b>
	<b>15.32 Guide roller Ø 60 mm</b>	01.06.2022 –	4982754	Unit(s) _____	<b>50,00 /each</b>
	<b>15.33 Adjusting rings, distance sleeves</b>	01.06.2022 –	4982755	Unit(s) _____	<b>96,00 /each</b>
	<b>15.34 Complete spiral support</b> Right Left  LDH ≤ 3600 mm Right Left <b>Note:</b> From 01.06.2022 – 01.06.2025 the LDH value is irrelevant.	01.06.2022 – 01.06.2022 –  01.06.2025 – 01.06.2025 –	4982756 4982757  7992276 7992275	Unit(s) _____ _____  _____ _____	<b>979,00 /each</b> <b>979,00 /each</b>  <b>797,00 /each</b> <b>797,00 /each</b>
	<b>15.35 Side cladding for top part</b> Right Left  LDH ≤ 3600 mm Right Left <b>Note:</b> From 01.06.2022 – 01.06.2025 the LDH value is irrelevant.	01.06.2022 – 01.06.2022 –  01.06.2025 – 01.06.2025 –	4982758 4982759  7992643 7992644	Unit(s) _____ _____  _____ _____	<b>290,00 /each</b> <b>290,00 /each</b>  <b>242,00 /each</b> <b>242,00 /each</b>
	<b>15.36 Rotary encoder Multiturn</b>	01.06.2022 –	4982215	Unit(s) _____	<b>350,00 /each</b>

\* State purchase order number

# 15. High-speed door HS 5040 TurboLux (S)

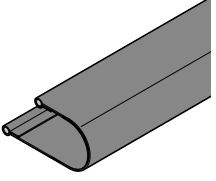
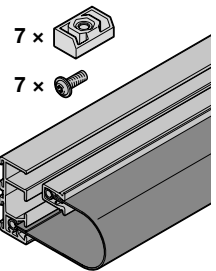
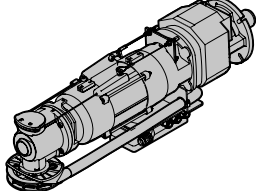
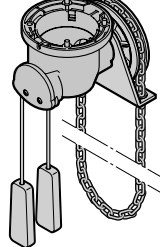
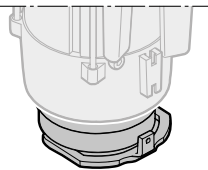
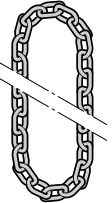
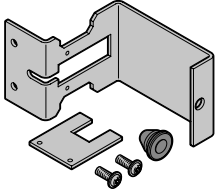
Article	Item Description	Production period	Art. no.	Quantity	€
	* <b>15.37 Curtain loop complete</b> 80 mm	01.06.2022 –	4991415	m _____	<b>24,00 / m</b>
	* <b>15.38 Lintel seal complete</b>	01.06.2022 –	4982750	Unit(s) _____ _____	<b>24,00 / m</b> <b>123,00 / each</b>
	<b>15.39 Operator</b> With brake ventilation, 1-phase Without brake ventilation, 3-phase	01.06.2022 – 01.06.2022 –	4982620 4982619	Unit(s) _____ _____	<b>2553,00 / each</b> <b>2553,00 / each</b>
	<b>15.40 Emergency hand chain gearbox</b> Gear reduction 1:4.5	01.06.2022 –	4982760	Unit(s) _____	<b>854,00 / each</b>
	<b>15.41 Brake 11 Nm</b>	01.06.2022 –	4982845	Unit(s) _____	<b>1054,00 / each</b>
	<b>15.42 Hand chain</b> 10000 mm long with 1 chain link	01.06.2022 –	4982733	Unit(s) _____	<b>52,00 / each</b>
	<b>15.43 Retaining plate</b> For rotary encoder	01.06.2022 –	4982761	Unit(s) _____	<b>91,00 / each</b>

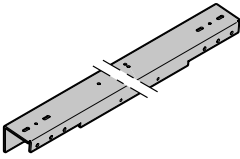
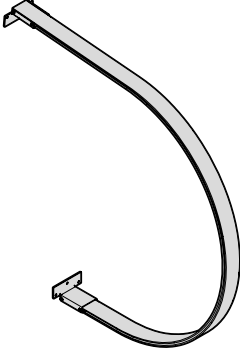
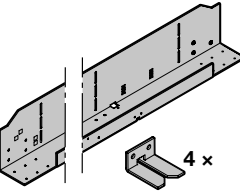
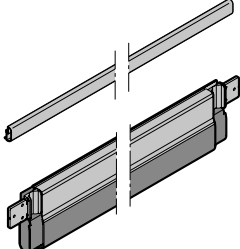
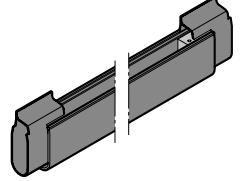
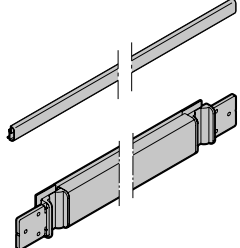

\* State purchase order number

# 15. High-speed door HS 5040 TurboLux (S)

Article	Item Description	Production period	Art. no.	Quantity	€
	<p><b>* 15.44 Top reinforcement profile</b></p> <p>LDH ≤ 3600 mm</p> <p><b>Note:</b> From 01.06.2022 – 01.06.2025 the LDH value is irrelevant.</p>	01.06.2022 –	4982762	Unit(s)	<b>64,00 / m</b>
		01.06.2025 –	7992044		<b>61,00 / each</b> <b>64,00 / m</b> <b>61,00 / each</b>
	<p><b>15.45 Support yoke</b></p> <p>For complete cladding LDH ≤ 3600 mm</p> <p><b>Note:</b> From 01.06.2022 – 01.06.2025 the LDH value is irrelevant.</p>	01.06.2022 –	4982763	Unit(s)	<b>86,00 / m</b>
		01.06.2025 –	7992640		<b>86,00 / each</b>
	<p><b>* 15.46 Reinforcement profile rear, complete</b></p> <p>LDH ≤ 3600 mm</p> <p><b>Note:</b> From 01.06.2022 – 01.06.2025 the LDH value is irrelevant.</p>	01.06.2022 –	4982764	Unit(s)	<b>102,00 / m</b>
		01.06.2025 –	7992645		<b>197,00 / each</b> <b>102,00 / m</b> <b>197,00 / each</b>
	<p><b>* 15.47 Bottom part</b></p>	01.06.2022 –	4982765	Unit(s)	<b>271,00 / m</b>
					<b>252,00 / each</b>
	<p><b>* 15.48 sealing</b></p> <p>For bottom part, complete</p>	01.06.2022 –	4982766	Unit(s)	<b>30,00 / m</b>
	<p><b>* 15.49 Wind reinforcement lath</b></p>	01.06.2022 –	4982767	Unit(s)	<b>70,00 / m</b>
					<b>52,00 / each</b>

\* State purchase order number

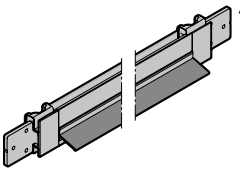
# 15. High-speed door HS 5040 TurboLux (S)

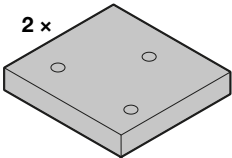
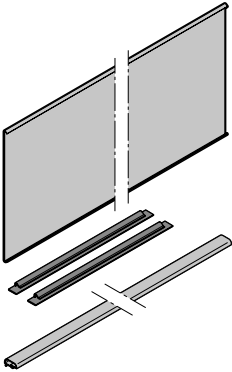
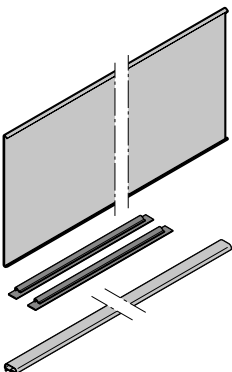
Article	Item Description	Production period	Art. no.	Quantity	€
	<p><b>15.50 Wind reinforcement lath</b></p> <p>For lintel seal</p>	01.06.2022 –	4982768	Unit(s)	<p>52,00 / m</p> <p>141,00 / each</p>
<p>6 x </p> <p>2 x </p>	<p><b>15.51 Set: fixing material</b></p> <p>for wind locks and bottom part</p>	01.06.2022 –	7992682	Unit(s)	17,00 / each
	<p><b>* 15.52 Upper polycarbonate pane Complete</b></p> <p>for door leaf</p> <p><input type="checkbox"/> Without foil coating</p> <p>for door leaf</p> <p><input type="checkbox"/> Without foil coating</p> <p>With foil coating</p> <p><input type="checkbox"/> Translucent Yellow</p> <p><input type="checkbox"/> Translucent Orange</p> <p><input type="checkbox"/> Translucent Dark Red</p> <p><input type="checkbox"/> Translucent Electric Blue</p> <p><input type="checkbox"/> Translucent Black</p> <p><input type="checkbox"/> Translucent Silver</p> <p>With foil coating</p> <p>RAL 9006 White aluminium</p> <p>RAL 1018 Zinc yellow</p> <p>RAL 5010 Gentian blue</p> <p>RAL 2004 Pure orange</p> <p>RAL 9005 Jet black</p>	<p>01.06.2022 – 31.05.2025</p> <p>01.06.2025 –</p> <p>28.02.2026 –</p> <p>28.02.2026 –</p> <p>28.02.2026 –</p> <p>28.02.2026 –</p> <p>28.02.2026 –</p> <p>28.02.2026 –</p> <p>01.03.2026 –</p> <p>01.03.2026 –</p> <p>01.03.2026 –</p> <p>01.03.2026 –</p>	<p>4982769</p> <p>7992812</p> <p></p> <p></p> <p></p> <p></p> <p></p> <p></p> <p></p> <p></p>	Unit(s)	<p>310,00 / each</p> <p>310,00 / each</p> <p>530,00 / each</p> <p>530,00 / each</p> <p>530,00 / each</p> <p>530,00 / each</p> <p>530,00 / each</p> <p>530,00 / each</p> <p>530,00 / each</p> <p>530,00 / each</p>
	<p><b>* 15.53 Polycarbonate pane Complete</b></p> <p>for door leaf</p> <p><input type="checkbox"/> Without foil coating</p> <p>With foil coating</p> <p><input type="checkbox"/> Translucent Yellow</p> <p><input type="checkbox"/> Translucent Orange</p> <p><input type="checkbox"/> Translucent Dark Red</p> <p><input type="checkbox"/> Translucent Electric Blue</p> <p><input type="checkbox"/> Translucent Black</p> <p><input type="checkbox"/> Translucent Silver</p> <p>With foil coating</p> <p>RAL 9006 White aluminium</p> <p>RAL 1018 Zinc yellow</p> <p>RAL 5010 Gentian blue</p> <p>RAL 2004 Pure orange</p> <p>RAL 9005 Jet black</p>	<p>01.06.2022 –</p> <p>28.02.2026 –</p> <p>28.02.2026 –</p> <p>28.02.2026 –</p> <p>28.02.2026 –</p> <p>28.02.2026 –</p> <p>28.02.2026 –</p> <p>01.03.2026 –</p> <p>01.03.2026 –</p> <p>01.03.2026 –</p> <p>01.03.2026 –</p>	<p>4982769</p> <p></p> <p></p> <p></p> <p></p> <p></p> <p></p> <p></p> <p></p> <p></p>	Unit(s)	<p>310,00 / each</p> <p>530,00 / each</p> <p>530,00 / each</p> <p>530,00 / each</p> <p>530,00 / each</p> <p>530,00 / each</p> <p>530,00 / each</p> <p>530,00 / each</p> <p>530,00 / each</p> <p>530,00 / each</p>

\* State purchase order number

# 15. High-speed door HS 5040 TurboLux (S)

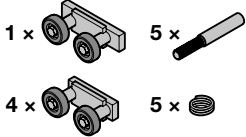
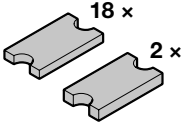
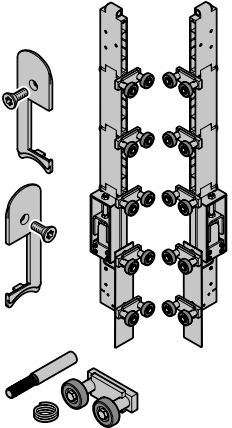
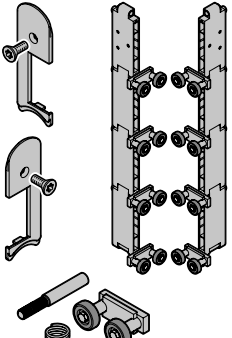
Article	Item Description	Production period	Art. no.	Quantity	€
	<b>15.54 Set: twin rollers</b> <b>Note:</b> Additionally required: set: door leaf fixing fork, set: fitting device	01.06.2022 –	7992660	Unit(s) _____	<b>98,00 /each</b>
	<b>15.55 Set: Glider</b> <b>Note:</b> Additionally required: double ring ratchet spanner with collar	01.06.2022 –	4982712	Unit(s) _____	<b>40,00 /each</b>
	<b>15.56 Hinge section bottom, complete</b> Right Left <b>Note:</b> Additionally required: set: fixing forks, set: fitting device	01.06.2022 – 01.06.2022 –	4982770 4982771	Unit(s) _____ _____	<b>234,00 /each</b> <b>234,00 /each</b>
	<b>15.57 Hinge section centre, complete</b> Right Left <b>Note:</b> Additionally required: set: door leaf fixing fork, set: fitting device	01.06.2022 – 01.06.2022 –	4982772 4982773	Unit(s) _____ _____	/each <b>123,00 /each</b>

\* State purchase order number

# 15. High-speed door HS 5040 TurboLux (S)

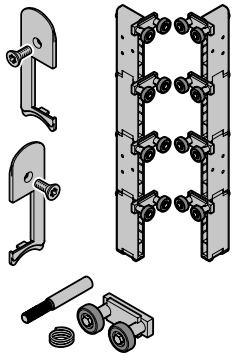
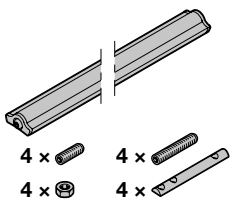
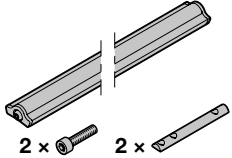
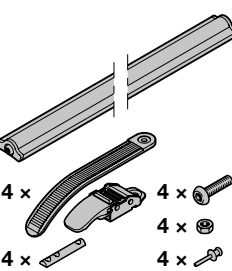
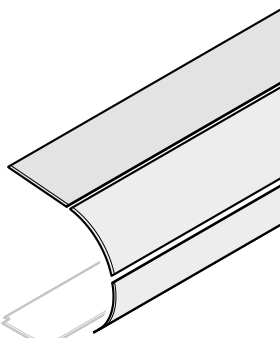
Article	Item Description	Production period	Art. no.	Quantity	€
	<p><b>* 15.58 Hinge section top, complete</b></p> <p>Right Left</p> <p><b>1-piece</b> Right Left</p> <p><b>2-part</b> Right Left</p> <p><b>3-part</b> Right Left</p> <p><b>4-part</b> Right Left</p> <p><b>Note:</b> Additionally required: set: door leaf fixing fork, set: fitting device</p>	<p>01.06.2022 – 01.06.2022 –</p> <p>01.06.2025 – 01.06.2025 –</p> <p>01.06.2025 – 01.06.2025 –</p> <p>01.06.2025 – 01.06.2025 –</p> <p>01.06.2025 – 01.06.2025 –</p> <p>01.06.2025 – 01.06.2025 –</p>	<p>4982774 4982775</p> <p>7992650 7992649</p> <p>7992652 7992651</p> <p>7992654 7992653</p> <p>7992656 7992655</p>	<p>Unit(s)</p> <p>_____ _____ _____ _____ _____ _____ _____ _____ _____ _____</p>	<p><b>141,00 / each</b> <b>141,00 / each</b></p> <p><b>67,00 / each</b> <b>67,00 / each</b></p> <p><b>106,00 / each</b> <b>106,00 / each</b></p> <p><b>147,00 / each</b> <b>147,00 / each</b></p> <p><b>187,00 / each</b> <b>187,00 / each</b></p>
	 <p><b>* 15.59 Top crossbar, complete</b> For cladding</p>	01.06.2022 –	4982776	Unit(s) _____	<b>330,00 / each</b>
	 <p><b>* 15.60 Centre crossbar, complete</b> For cladding and spiral support</p>	01.06.2022 –	4982777	Unit(s) _____	<b>313,00 / each</b>
	 <p><b>* 15.61 Bottom crossbar, complete</b> For cladding</p>	01.06.2022 –	4982778	Unit(s) _____	<b>452,00 / each</b>
	 <p><b>* 15.62 Polycarbonate pane, top</b> For cladding</p> <p>Without foil coating</p> <p>With foil coating</p> <p><input type="checkbox"/> Translucent Yellow</p> <p><input type="checkbox"/> Translucent Orange</p> <p><input type="checkbox"/> Translucent Dark Red</p> <p><input type="checkbox"/> Translucent Electric Blue</p> <p><input type="checkbox"/> Translucent Black</p> <p><input type="checkbox"/> Translucent Silver</p>	01.06.2022 – 31.05.2025	4982780	Unit(s) _____ _____ _____ _____ _____ _____	<p><b>201,00 / each</b></p> <p><b>375,00 / each</b> <b>375,00 / each</b> <b>375,00 / each</b> <b>375,00 / each</b> <b>375,00 / each</b> <b>375,00 / each</b></p>

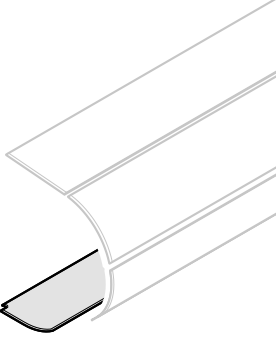
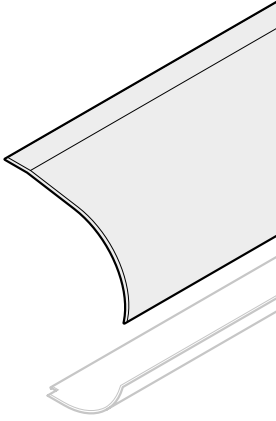
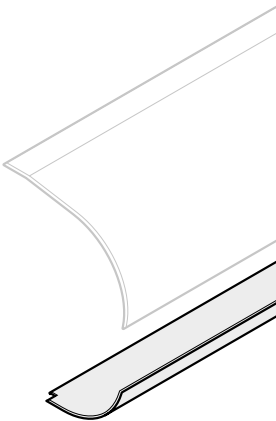
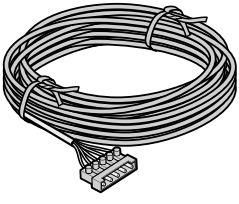

\* State purchase order number

# 15. High-speed door HS 5040 TurboLux (S)

Article	Item Description	Production period	Art. no.	Quantity	€			
	<p><b>* 15.63 Polycarbonate pane, bottom</b> For cladding</p> <p>Without foil coating</p> <p>With foil coating</p> <p><input type="checkbox"/> Translucent Yellow</p> <p><input type="checkbox"/> Translucent Orange</p> <p><input type="checkbox"/> Translucent Dark Red</p> <p><input type="checkbox"/> Translucent Electric Blue</p> <p><input type="checkbox"/> Translucent Black</p> <p><input type="checkbox"/> Translucent Silver</p>	<p>01.06.2022 – 31.05.2025</p> <p>01.06.2022 – 31.05.2025</p> <p>01.06.2022 – 31.05.2025</p> <p>01.06.2022 – 31.05.2025</p> <p>01.06.2022 – 31.05.2025</p> <p>01.06.2022 – 31.05.2025</p>	<p>4982779</p>	<p>Unit(s)</p> <p>_____</p> <p>_____</p> <p>_____</p> <p>_____</p> <p>_____</p> <p>_____</p>	<p><b>201,00 /each</b></p> <p><b>375,00 /each</b></p> <p><b>375,00 /each</b></p> <p><b>375,00 /each</b></p> <p><b>375,00 /each</b></p> <p><b>375,00 /each</b></p> <p><b>375,00 /each</b></p>			
		<p><b>* 15.64 Polycarbonate pane, top</b> For cladding</p> <p>Without foil coating</p> <p>With foil coating</p> <p><input type="checkbox"/> Translucent Yellow</p> <p><input type="checkbox"/> Translucent Orange</p> <p><input type="checkbox"/> Translucent Dark Red</p> <p><input type="checkbox"/> Translucent Electric Blue</p> <p><input type="checkbox"/> Translucent Black</p> <p><input type="checkbox"/> Translucent Silver</p>	<p>01.06.2025 –</p> <p>01.06.2025 –</p> <p>01.06.2025 –</p> <p>01.06.2025 –</p> <p>01.06.2025 –</p> <p>01.06.2025 –</p>	<p>7992897</p>	<p>Unit(s)</p> <p>_____</p> <p>_____</p> <p>_____</p> <p>_____</p> <p>_____</p> <p>_____</p>	<p><b>268,00 /each</b></p> <p><b>500,00 /each</b></p> <p><b>500,00 /each</b></p> <p><b>500,00 /each</b></p> <p><b>500,00 /each</b></p> <p><b>500,00 /each</b></p> <p><b>500,00 /each</b></p>		
			<p><b>* 15.65 Polycarbonate pane, bottom</b> For cladding</p> <p>Without foil coating</p> <p>With foil coating</p> <p><input type="checkbox"/> Translucent Yellow</p> <p><input type="checkbox"/> Translucent Orange</p> <p><input type="checkbox"/> Translucent Dark Red</p> <p><input type="checkbox"/> Translucent Electric Blue</p> <p><input type="checkbox"/> Translucent Black</p> <p><input type="checkbox"/> Translucent Silver</p>	<p>01.06.2025 –</p> <p>01.06.2025 –</p> <p>01.06.2025 –</p> <p>01.06.2025 –</p> <p>01.06.2025 –</p> <p>01.06.2025 –</p>	<p>7992896</p>	<p>Unit(s)</p> <p>_____</p> <p>_____</p> <p>_____</p> <p>_____</p> <p>_____</p> <p>_____</p>	<p><b>268,00 /each</b></p> <p><b>500,00 /each</b></p> <p><b>500,00 /each</b></p> <p><b>500,00 /each</b></p> <p><b>500,00 /each</b></p> <p><b>500,00 /each</b></p> <p><b>500,00 /each</b></p>	
				<p><b>* 15.66 Motor cable</b></p> <p>Lengths [mm]</p> <p>4000</p> <p>7000</p> <p>11.000</p> <p>16.000</p> <p>21.000</p>	<p>01.06.2022 –</p> <p>01.06.2022 –</p> <p>01.06.2022 –</p> <p>01.06.2022 –</p> <p>01.06.2022 –</p>	<p>4982269</p> <p>4982267</p> <p>4982781</p> <p>4982782</p> <p>4982783</p>	<p>Unit(s)</p> <p>_____</p> <p>_____</p> <p>_____</p> <p>_____</p> <p>_____</p>	<p><b>51,00 /each</b></p> <p><b>62,00 /each</b></p> <p><b>97,00 /each</b></p> <p><b>151,00 /each</b></p> <p><b>188,00 /each</b></p>

\* State purchase order number

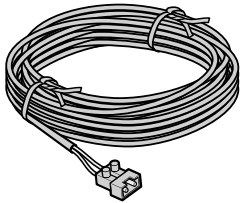
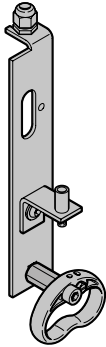
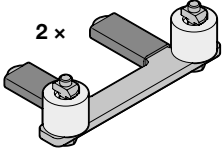
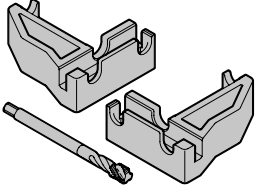
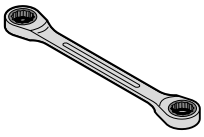
# 15. High-speed door HS 5040 TurboLux (S)

Article	Item Description	Production period	Art. no.	Quantity	€	
	<p><b>* 15.67 Cable brake / NA</b></p> <p>Lengths [mm]</p> <p>4000</p> <p>7000</p> <p>11.000</p> <p>16.000</p> <p>21.000</p>	<p>01.06.2022 –</p> <p>01.06.2022 –</p> <p>01.06.2022 –</p> <p>01.06.2022 –</p> <p>01.06.2022 –</p>	<p>4982614</p> <p>4982266</p> <p>4982784</p> <p>4982785</p> <p>4982786</p>	<p>Unit(s)</p> <p>_____</p> <p>_____</p> <p>_____</p> <p>_____</p> <p>_____</p>	<p><b>37,00 / each</b></p> <p><b>43,00 / each</b></p> <p><b>53,00 / each</b></p> <p><b>73,00 / each</b></p> <p><b>83,00 / each</b></p>	
		<p><b>* 15.68 Emergency handle</b></p> <p>Right</p> <p>Left</p>	<p>01.06.2022 –</p> <p>01.06.2022 –</p>	<p>4982847</p> <p>4982846</p>	<p>Unit(s)</p> <p>_____</p> <p>_____</p>	<p><b>89,00 / each</b></p> <p><b>129,00 / each</b></p>
		<p><b>2 x</b></p> 	<p><b>15.69 Fixing fork door leaf</b></p>	<p>01.06.2022 –</p>	<p>4982822</p>	<p>Unit(s)</p> <p>_____</p>
		<p><b>15.70 Set: Hinge section fitting device</b></p>	<p>01.06.2022 –</p>	<p>4982823</p>	<p>Unit(s)</p> <p>_____</p>	<p><b>129,00 / each</b></p>
		<p><b>15.71 Double ring ratchet spanner with collar</b></p> <p>For replacing the twin roller gliders</p>	<p>01.06.2022 –</p>	<p>7992661</p>	<p>Unit(s)</p> <p>_____</p>	<p><b>48,00 / each</b></p>
		<p><b>15.72 Bowden cable</b></p> <p>Required length: LDH + 500 mm</p>	<p>01.06.2022 –</p>	<p>157317</p>	<p>Unit(s)</p> <p>_____</p>	<p><b>19,20 / each</b></p>

\* State purchase order number

# 15. High-speed door HS 5040 TurboLux (S)

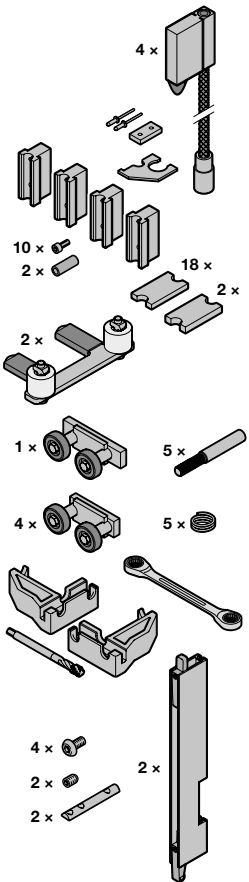
Article	Item Description	Production period	Art. no.	Quantity	€
 <p>4 x</p> <p>10 x</p> <p>2 x</p> <p>18 x</p> <p>2 x</p> <p>2 x</p> <p>1 x</p> <p>5 x</p> <p>4 x</p> <p>5 x</p> <p>4 x</p> <p>2 x</p> <p>2 x</p> <p>2 x</p>	<p><b>15.73 Set: TurboLux starter kit</b> Maintenance and inspection</p>	01.06.2022 –	7992693	Unit(s)	<b>1004,00 /each</b>

\* State purchase order number

# HS 5015 PU N 42 S

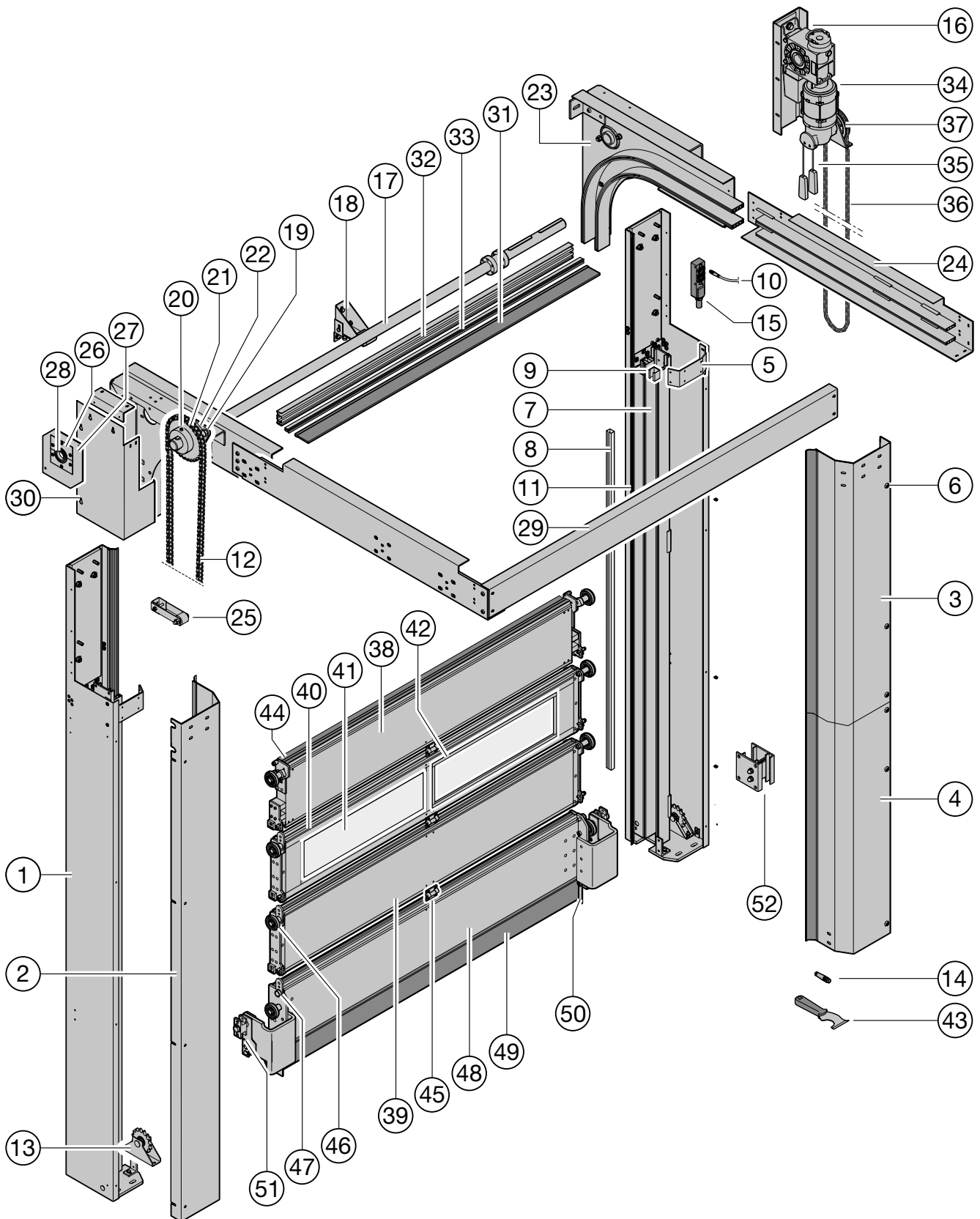

# 16. High-speed door HS 5015 PU N 42 S

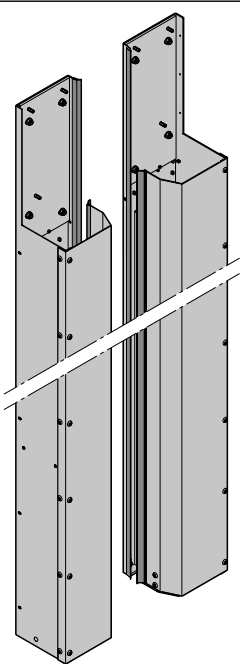
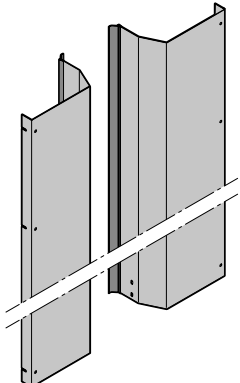
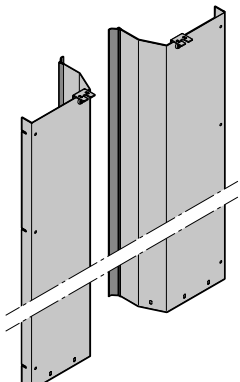
Article	Item	Description	Production period	Art. no.	Quantity	€
	*	<b>16.1 Side element</b>			Unit(s)	
		Right	01.03.2025 –	7992230	_____	/ each
		Left	01.03.2025 –	7992231	_____	/ each
	*	<b>16.2 Cover, 1-part</b>			Unit(s)	
		DE – DA $\geq$ – 3745 mm Right	01.03.2025 –	7992156	_____	/ m
	Left	01.03.2025 –	7992157	_____	/ m	
	*	<b>16.3 Top cover, 2-part</b>			Unit(s)	
		DE – DA $\geq$ 3745 – $\leq$ 6245 mm Right	01.03.2025 –	7992159	_____	/ m
	Left	01.03.2025 –	7992161	_____	/ m	



\* State purchase order number

Surcharge for high-quality wet coating panel (see page 173)

EN Ceiling height



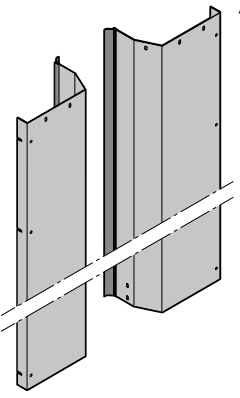
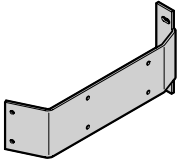

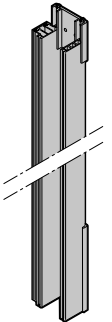
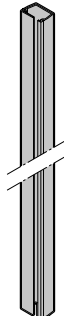
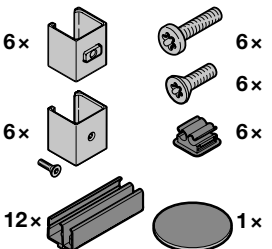

DA Distance to ceiling

# 16. High-speed door HS 5015 PU N 42 S

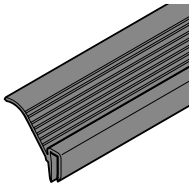
Article	Item	Description	Production period	Art. no.	Quantity	€
	* 16.4	<b>Bottom cover, 2-part</b>			Unit(s)	
		DE – DA ≥ 3745 – ≤ 6245 mm	01.03.2025 –	7992158	_____	/ m
		Right	01.03.2025 –	7992158	_____	/ each
		Left	01.03.2025 –	7992160	_____	/ m
						/ each
	16.5	<b>Cover bar</b>	01.03.2025 –	4991910	Unit(s)	/ each
 50x	16.6	<b>Self-tapping screws M6 x 12</b> Screws for cover		4992181	Unit(s)	/ each
	* 16.7	<b>Complete aluminium profile guide</b>			Unit(s)	
		Right	01.03.2025 –	7992344	_____	/ m
		Left	01.03.2025 –	7992345	_____	/ each
						/ m
						/ each
	* 16.8	<b>Light grille</b> For article numbers and lengths see pages 176 – 178 light grille / cable concept	01.03.2025 –		Unit(s)	/ each
 6x 6x 12x 6x 6x 1x	16.9	<b>Light grille replacement accessories</b> From 01.06.2021 onwards, the bag is required when replacing the light grille.	01.03.2025 –	4982111	Unit(s)	/ each

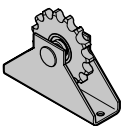
\* State purchase order number  
 Surcharge for high-quality wet coating panel (see page 173)  
 EN Ceiling height  
 DA Distance to ceiling

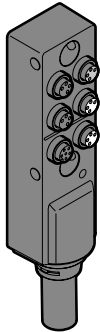
# 16. High-speed door HS 5015 PU N 42 S

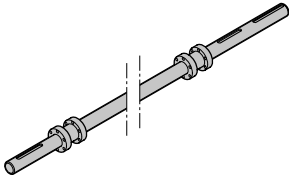
Article	Item	Description	Production period	Art. no.	Quantity	€
	*	<b>16.10 Snap cable, white, light grille</b> For article numbers and lengths see pages 176 – 178 light grille / cable concept	01.03.2025 –		Unit(s) _____	/ each
	*	<b>16.11 Seal for guide</b> Additional 2 × per side element required  4000 mm 5000 mm 6000 mm	01.03.2025 – 01.03.2025 – 01.03.2025 –	4991585 4991586 4991490	Unit(s) _____ _____ _____	/ each / each / each
		<b>16.12 Roller chain reinforced</b>	01.03.2025 –	159568	m _____	/ m
		<b>16.13 Complete chain tensioner wheel</b>  Right Left	01.03.2025 – 01.03.2025 –	4990809 4990810	Unit(s) _____ _____	/ each / each
		<b>16.14 Bridge plug snap 8</b>	01.03.2025 –	4980188	Unit(s) _____	/ each
	*	<b>16.15 Distributor 6 × M8 snap</b> For article numbers and lengths see pages 176 – 178 light grille / cable concept	01.03.2025 –		Unit(s) _____	/ each
		<b>16.16 Complete operator support bracket</b>	01.03.2025 –	4990800	Unit(s) _____	/ each
	*	<b>16.17 Complete shaft</b>	01.03.2025 –	7992232	Unit(s) _____	/ m / each





\* State purchase order number

Surcharge for high-quality wet coating panel (see page 173)

EN Ceiling height

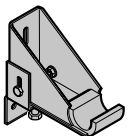
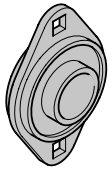
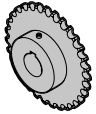
DA Distance to ceiling

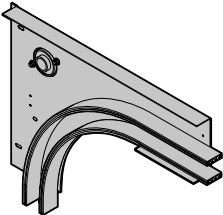
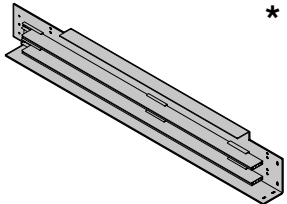
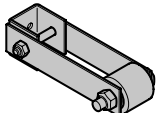
# 16. High-speed door HS 5015 PU N 42 S

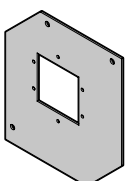
Article	Item	Description	Production period	Art. no.	Quantity	€
	16.18	Shaft support	01.03.2025 –	4990877	Unit(s) _____	/ each
	16.19	Grooved ball-bearing ASPFL 208	01.03.2025 –	159403	Unit(s) _____	/ each
	16.20	Chain sprocket	01.03.2025 –	4990808	Unit(s) _____	/ each
	16.21	Distance sleeve 10 mm	01.03.2025 –	4991703	Unit(s) _____	/ each
	16.22	Adjusting ring	01.03.2025 –	159163	Unit(s) _____	/ each
	*	16.23 Complete support curve			Unit(s)	
		Right	01.03.2025 –	4982788	_____	/ each
		Left	01.03.2025 –	4982789	_____	/ each
	*	16.24 Complete horizontal guide			Unit(s)	
		Right	01.03.2025 –	7992237	_____	/ m
		Left	01.03.2025 –	7992238	_____	/ m
	16.25	Complete return pulley	01.03.2025 –	4991214	Unit(s) _____	/ each
	16.26	Retaining plate for bearing per door (2 units)	01.03.2025 –	7992171	Unit(s) _____	/ each
	16.27	Sheet bearing	01.03.2025 –	4981655	Unit(s) _____	/ each

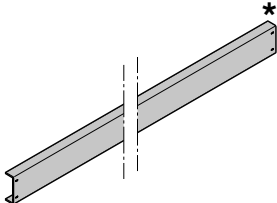
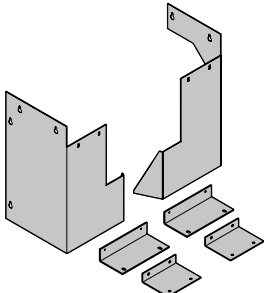
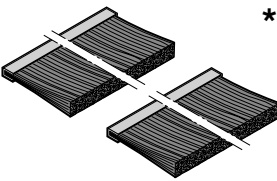
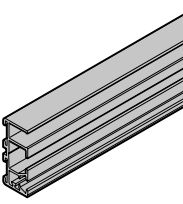
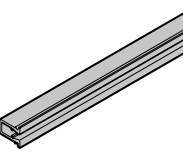
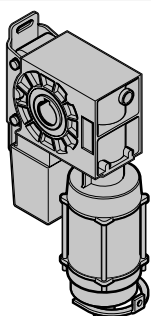

\* State purchase order number  
 Surcharge for high-quality wet coating panel (see page 173)  
 EN Ceiling height  
 DA Distance to ceiling

# 16. High-speed door HS 5015 PU N 42 S

Article	Item Description	Production period	Art. no.	Quantity	€
	<b>16.28 Ball-bearing with groove</b>	01.03.2025 –	158993	Unit(s) _____	/ each
	<b>16.29 Transverse cross strut</b>	01.03.2025 –	7992164	Unit(s) _____	/ m
	<b>16.30 Cladding, complete</b>	01.03.2025 –	7992248	Unit(s) _____	/ each
	<b>16.31 Brush seal</b>	01.03.2025 –	4982186	Unit(s) _____	/ each
	<b>16.32 Sealing frame channel</b> 4000 mm 5000 mm 6000 mm	01.03.2025 – 01.03.2025 – 01.03.2025 –	4991263 4991770 4991426	Unit(s) _____ _____ _____	/ each / each / each
	<b>16.33 Sealing frame clips</b> 4000 mm 5000 mm 6000 mm	01.03.2025 – 01.03.2025 – 01.03.2025 –	4991264 4991771 4991427	Unit(s) _____ _____ _____	/ each / each / each
	<b>16.34 Operator</b>			Unit(s) _____	/ each

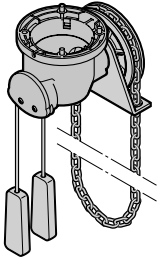
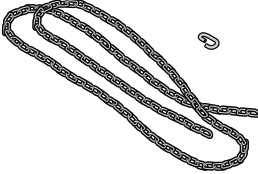

\* State purchase order number  
 Surcharge for high-quality wet coating panel (see page 173)  
 EN Ceiling height  
 DA Distance to ceiling

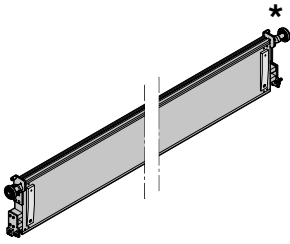
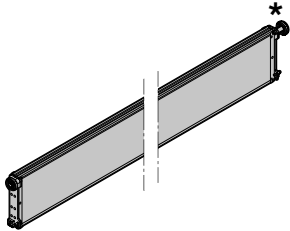
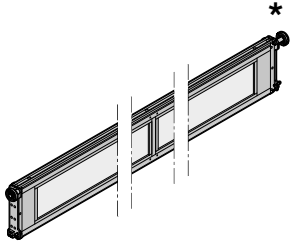
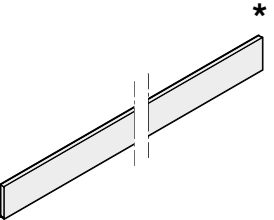
# 16. High-speed door HS 5015 PU N 42 S

Article	Item Description	Production period	Art. no.	Quantity	€
	<b>16.35 Emergency hand chain gearbox</b>	01.03.2025 –	158171	Unit(s) _____	/ each
	<b>16.36 hand chain 10 m</b> With chain link	01.03.2025 –	4982733	Unit(s) _____	/ each
	<b>16.37 Brake 11 Nm 24 V LH U</b>	01.03.2025 –	4982120	Unit(s) _____	/ each
	<b>16.38 Complete top panel</b> Section height: 250 mm Standard version: RAL 9006	01.03.2025 –	7992235	Unit(s) _____	/ m / each
	<b>16.39 Inclination panel</b> Section height: 250 mm Standard version: RAL 9006	01.03.2025 –	7992233	Unit(s) _____	/ m / each
	<b>16.40 Complete window profile Double glazing</b> Section height: 250 mm Standard version: RAL 9006	01.03.2025 –	7992234	Unit(s) _____	/ m / each
	<b>16.41 Double pane</b>	01.03.2025 –		Unit(s) _____	/ each

\* State purchase order number  
 Surcharge for high-quality wet coating panel (see page 173)  
 EN Ceiling height  
 DA Distance to ceiling

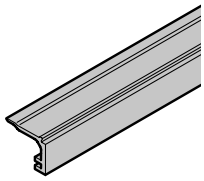
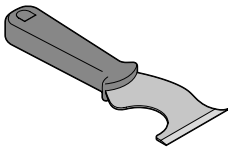
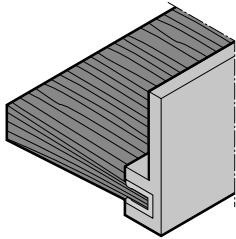
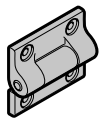
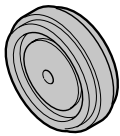
# 16. High-speed door HS 5015 PU N 42 S

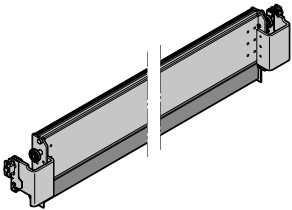
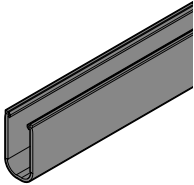
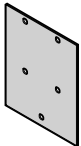
Article	Item Description	Production period	Art. no.	Quantity	€
	* <b>16.42 Glazing bead</b> Short, 160.8 mm Long per / m	01.03.2025 – 01.03.2025 –	4992192 4992194	Unit(s) _____ _____	/ each / m
	<b>16.43 Hand scraper</b>	01.03.2025 –	4981136	Unit(s) _____	/ each
	* <b>16.44 Panel lintel seal</b>	01.03.2025 –	4982187	Unit(s) _____	/ each
	<b>16.45 Complete centre hinge</b> With screws  black Silver	01.03.2025 – 01.03.2025 –	4991905 4991904	Unit(s) _____ _____	/ each / each
	<b>16.46 Roller with band</b> For panels	01.03.2025 –	4990818	Unit(s) _____	/ each
	<b>16.47 Complete hinge connector</b>	01.03.2025 –	4981937	Unit(s) _____	/ each
	<b>16.48 Bottom part Complete</b>	01.03.2025 –	7992236	Unit(s) _____	/ m / each
	* <b>16.49 Rubber profile Velcro strap</b> (additionally required: Velcro strap 1 m)	01.03.2025 – 01.03.2025 –	4980601 159601	Unit(s) _____ _____	/ m / m
	<b>16.50 UPVC canopy</b>	01.03.2025 –	4992208	Unit(s) _____	/ each

\* State purchase order number

Surcharge for high-quality wet coating panel (see page 173)

EN Ceiling height

DA Distance to ceiling

# 16. High-speed door HS 5015 PU N 42 S

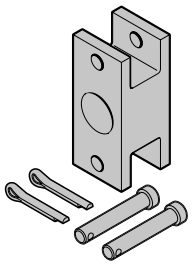
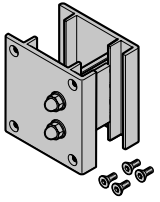
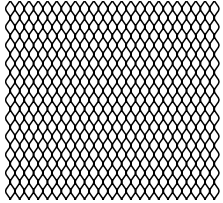
Article	Item Description	Production period	Art. no.	Quantity	€
	<b>16.51 Complete chain connection</b>	01.03.2025 –	4991430	Unit(s) _____	/ each
	<b>16.52 Fixing clip</b> To hold the curtain in place when exchanging panels	01.03.2025 –	4990854	Unit(s) _____	/ each
	<b>16.53 Ventilation grille</b>	01.03.2025 –	4981282	Unit(s) _____	/ m. / each

- \* State purchase order number
- Surcharge for high-quality wet coating panel (see page 173)
- EN Ceiling height
- DA Distance to ceiling

# 17. High-quality wet coating

Item	High-speed doors HS and IsoSpeed Cold 100 doors	Art. no.: High-quality wet coating	Quantity	€
1.0	Door sections on both sides	4981138		m <sup>2</sup>
1.1	Door sections on both sides PERL colours			<b>High-quality wet coating + 50.00%</b>
1.2	Window profiles			m <sup>2</sup>
1.3	Shaft cover on 2 or 3 sides (only series HS 7030 PU 42)			<b>Per door</b>
1.4	Side elements			<b>Per door</b>

The following RAL colours are not available: 3007, 4006, 4007, 5004, 7021, 8022, 9004, 9005, 9011, 9017 and 9021. Fluorescent colours are also unavailable. Avoid using dark colours for doors that are exposed to the sun. This is because potential section deflection may limit the door's function.

Damage to the door resulting from this does not constitute a reason for complaint.

## 18. 1-phase / 3-phase controls, SmartControl

---

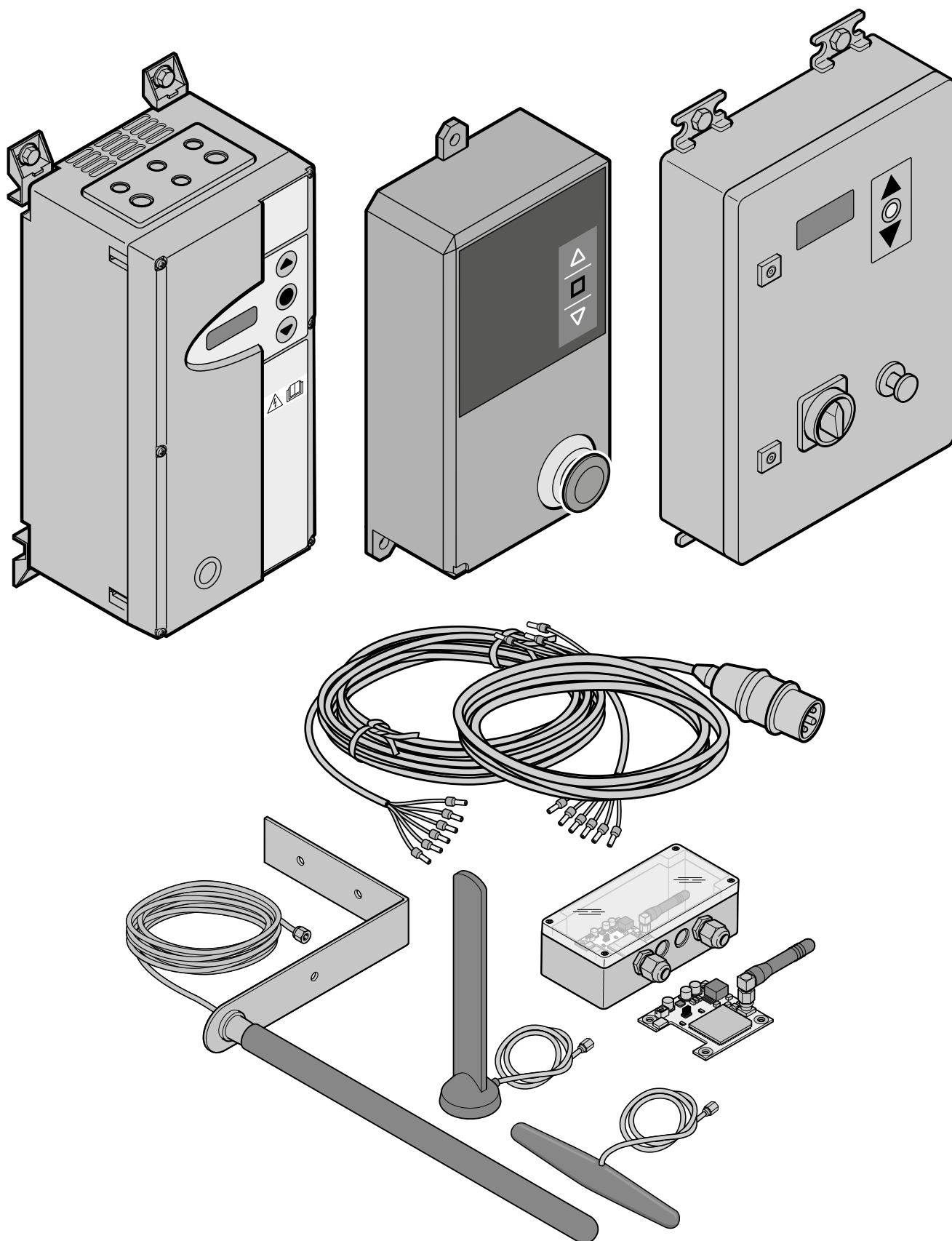

Item	Description	Art. no.	Quantity	€
<b>1</b>	<b>Control BK 150 FU</b>			
<b>2</b>	<b>Control BK 150 FUE H</b>			
<b>2.1</b>	Main circuit board	–		
<b>2.2</b>	Housing (only cover)			
<b>2.3</b>	Keypad	306421		/ each
<b>2.4</b>	Main switch	159611		/ each
<b>2.5</b>	Emergency-off	4980301		/ each
<b>3</b>	<b>Control BK 150 FUE-1</b>			
	Without main switch	4991937		/ each
	with main switch	4991962		/ each
	Main switch, emergency off	4991963		/ each
<b>3.1</b>	Main circuit board replacement	4981927		/ each
<b>3.2</b>	Housing			
	Without main switch	4980735		/ each
	with main switch	4980736		/ each
	With main switch and emergency-off	4980737		/ each
<b>3.3</b>	Keypad	306421		/ each
<b>3.4</b>	Main switch	159611		/ each
<b>3.5</b>	Emergency-off	4980301		/ each
<b>4</b>	<b>Control BS 150 FUE</b>			
<b>5</b>	<b>Control BS 150 FUEH</b>			
<b>5.1</b>	Main circuit board			
<b>5.2</b>	Housing			
<b>5.3</b>	Keypad	159669		/ each
<b>5.4</b>	Main switch	4980299		/ each
<b>5.5</b>	Emergency-off	4980303		/ each
<b>6</b>	<b>Control BS 150 FUE-1</b>	4991966		/ each
<b>6.1</b>	Main circuit board	4981927		/ each
<b>6.2</b>	Steel control box	4980739		/ each
	Stainless steel housing	4980740		/ each
<b>6.3</b>	Keypad	159669		/ each
<b>6.4</b>	Main switch	4980300		/ each
<b>6.5</b>	Emergency-off	4980303		/ each
<b>7</b>	<b>Control AKE</b>	157240		/ each
<b>7.1</b>	Main circuit board			
<b>7.2</b>	Housing	157909		/ each
<b>7.3</b>	Keypad (side) (from bottom)	157298 306815		/ each / each
<b>7.4</b>	Main switch	159611		/ each
<b>7.5</b>	Emergency-off	4980303		/ each
<b>8</b>	<b>Control ASE</b>	157468		/ each
<b>8.1</b>	Main circuit board	157336		/ each
<b>8.2</b>	Steel control box			
<b>8.3</b>	Keypad	159137		/ each
<b>8.4</b>	Main switch	4980300		/ each
<b>8.5</b>	Emergency-off	4980303		/ each
<b>9</b>	<b>Control AS 400 FUE</b>			
<b>10</b>	<b>Control AS 500 FUE</b>			
<b>11</b>	<b>Control AK 500 FUE-1</b>	4991970		/ each
<b>11.1</b>	Main circuit board replacement	4981928		/ each
<b>11.2</b>	Housing	4980738		/ each
<b>11.3</b>	Keypad	306421		/ each
<b>11.4</b>	Main switch	4991939		/ each
<b>11.5</b>	Emergency-off	4980306		/ each

<b>12</b>	<b>Control AS 500 FUE-1</b>	4991964		/ each
<b>12.1</b>	Main circuit board	4981928		/ each
<b>12.2</b>	Steel control box	4980739		/ each
	Stainless steel housing	4980740		/ each
<b>12.3</b>	Keypad	159669		/ each
<b>12.4</b>	Main switch	4991939		/ each
<b>12.5</b>	Emergency-off	4980303		/ each
<b>13</b>	<b>Control AKE light</b>	4982067		/ each
<b>13.1</b>	Housing	157909		/ each
<b>13.2</b>	Keypad	306815		/ each
<b>13.3</b>	Emergency-off	4980303		/ each

Item	Description	Art. no.	m	€
<b>1</b>	<b>Cable set BK 150 FU</b>			
<b>2</b>	<b>Cable set BK 150 FUE H</b>	306413	3	/ each
		306414	6	/ each
		306415	10	/ each
		306416	15	/ each
<b>3</b>	<b>Cable set AKE / ASE</b>	157481	3	/ each
		157482	6	/ each
		157483	10	/ each
		157484	15	/ each
<b>4</b>	<b>Cable set AS 400 FUE AS 500 FUE BS 150 FUE</b>			

<sup>1)</sup> According to the RoHS Directive, we have been prohibited from selling control components containing lead since mid-2017.

Item	Miscellaneous	Art. no.	€
<b>1</b>	Battery UPS 12 V <sup>2)</sup>	159407	/ each
<b>2</b>	Limit switch DES	158155	/ each
<b>3</b>	Brake rectifier GfA EGR2	159221	/ each

<sup>2)</sup> 2 batteries must always be ordered.

Item	Conversion BK 150 FU / BS 150 FUE BK 150 FUE H / BS 150 FUE H	Art. no.	€
<b>1</b>	on BK 150 FUE-1	4992200	/ each
<b>2</b>	on BS 150 FUE-1, steel	4992198	/ each
<b>3</b>	on BS 150 FUE-1, stainless steel	4992199	/ each
<b>4</b>	on BS 150 FUE-1, special version	4992201	



Item	Conversion AS 400 FUE AS 500 FUE	Art. no.	€
<b>1</b>	on AK 500 FUE-1	4981176	/ each
<b>2</b>	on AS 500 FUE-1, steel	4981177	/ each
<b>3</b>	on AS 500 FUE-1, stainless steel	4981178	/ each
<b>4</b>	on AS 500 FUE-1, special version	4981179	

When changing the control to the current generation, the compatibility of circuit boards, such as induction circuit boards or extension cards, must be checked.

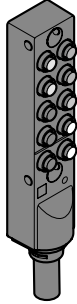
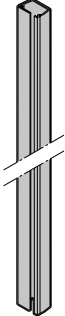

# 19. Light grille cable concept

Article	Item Description	Production period	Art. no.	Quantity	€
	<b>Light grille</b>	<b>01.03.2011 –31.05.2015</b>	4990761 4990758 4990757 4990756	Unit(s)	
	1615 mm			_____	/ each
	1985 mm			_____	/ each
	2355 mm			_____	/ each
	2715 mm			_____	/ each
	<b>Cable 15 m</b> (Receiver always fitted on left, only FUEH)	<b>01.03.2011 –31.05.2015</b>	4990759 4990760	Unit(s)	
	grey			_____	/ each
	black			_____	/ each
	<b>Light grille</b>	<b>01.06.2015 –31.05.2021</b>	4991949 4991948 4991947 4991946	Unit(s)	
	1615 mm			_____	/ each
	1985 mm			_____	/ each
	2355 mm			_____	/ each
	2715 mm			_____	/ each
	<b>Snap cable, white, 4-pin</b>	<b>01.06.2015 –31.05.2021</b>	4991890 4991891 4991892 4991893 4991894 4991895 4980190	Unit(s)	
	2000 mm			_____	/ each
	3000 mm			_____	/ each
	4000 mm			_____	/ each
	6000 mm			_____	/ each
	8000 mm			_____	/ each
	10000 mm			_____	/ each
	15000 mm			_____	/ each
	<b>Distributor 6 x M8 snap, black</b>	<b>01.06.2015 –31.05.2021</b>	4980179 4980180 4980181 4980182 4992008	Unit(s)	
	3500 mm			_____	/ each
	6500 mm			_____	/ each
	10500 mm			_____	/ each
	15500 mm			_____	/ each
	20500 mm			_____	/ each

# 19. Light grille cable concept

Article	Item Description	Production period	Art. no.	Quantity	€
	<b>Distributor 10 x M8 snap, black</b>  3500 mm 6500 mm 10500 mm 15500 mm 20500 mm	<b>01.06.2015 –31.05.2021</b>	4980183	Unit(s)	/ each
			4980184	_____	/ each
			4980185	_____	/ each
			4980186	_____	/ each
			4992007	_____	/ each
	<b>Snap cable, blue, spring / counter weight, 4-pin</b>  4000 mm 6000 mm 8000 mm 10000 mm 15000 mm 20000 mm	<b>01.06.2015 –31.05.2021</b>	4980252	Unit(s)	/ each
			4980253	_____	/ each
			4980254	_____	/ each
			4980255	_____	/ each
			4980256	_____	/ each
			4980257	_____	/ each
	<b>Light grille</b>  1212 mm 1572 mm 1932 mm 2292 mm 2652 mm  To replace the light grille, you also need the accessory bag 4982111.	<b>From 01.06.2021 –</b>	4981972	Unit(s)	/ each
			4982034	_____	/ each
			4981760	_____	/ each
			4981759	_____	/ each
			4981758	_____	/ each
	<b>Snap cable, white, 6-pin</b> For light grille  2000 mm 3000 mm 4000 mm 6000 mm 8000 mm 10000 mm 15000 mm	<b>From 01.06.2021 –</b>	4981763	Unit(s)	/ each
			4981764	_____	/ each
			4981765	_____	/ each
			4981766	_____	/ each
			4981767	_____	/ each
			4981768	_____	/ each
	<b>Distributor 4 x M8 snap</b> for V 4020 SEL-Alu R, V 4020 Protect  3500 mm 6500 mm 10500 mm 15500 mm 20500 mm	<b>From 01.06.2022 –</b>	4982836	Unit(s)	/ each
			4982887	_____	/ each
			4982906	_____	/ each
			4982907	_____	/ each
			4982908	_____	/ each

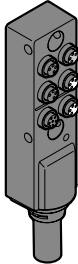
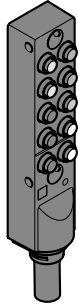
# 19. Light grille cable concept

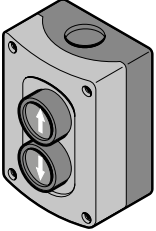
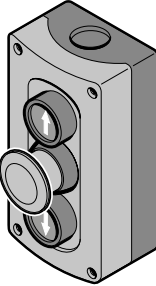
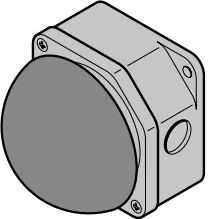
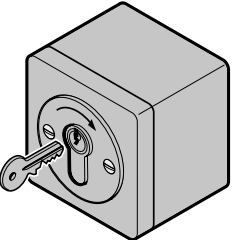
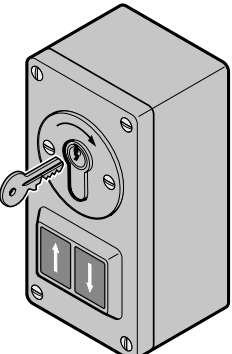
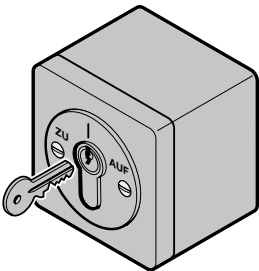

Article	Item Description	Production period	Art. no.	Quantity	€
	<b>Distributor 6 x M8 snap, grey</b>	<b>From 01.06.2021 –</b>	4982026 4981896 4981770 4982027 4982041	Unit(s)	
	3500 mm			_____	/ each
	6500 mm			_____	/ each
	10500 mm			_____	/ each
	15500 mm			_____	/ each
	20500 mm			_____	/ each
	<b>Distributor 10 x M8 snap, grey</b>	<b>From 01.06.2021 –</b>	4982029 4982030 4981851 4982031 4982032	Unit(s)	
	3500			_____	/ each
	6500			_____	/ each
	10500			_____	/ each
	15500			_____	/ each
	20500			_____	/ each
	<b>Snap cable, blue, spring / counter weight, 4-pin</b>	<b>From 01.06.2021 –</b>	4980252 4980253 4980254 4980255 4980256 4980257	Unit(s)	
	4000 mm			_____	/ each
	6000 mm			_____	/ each
	8000 mm			_____	/ each
	10000 mm			_____	/ each
	15000 mm			_____	/ each
20000 mm	_____	/ each			
	<b>Snap cable, yellow curtain belt monitoring</b>	<b>From 01.06.2021 –</b>	4992006 4992009 4992010	Unit(s)	
	4000 mm			_____	/ each
	6000 mm			_____	/ each
	8000 mm			_____	/ each

## 20. Accessories for operators and controls

Article	Item	Description	Production period	Art. no.	Quantity	€
	20.1	Push button, surface-mounted		159763	Unit(s) _____	/ each
	20.2	Push button for Open / Emergency-off / Close, surface-mounted fitting		159749	Unit(s) _____	/ each
	20.3	Mushroom button, push button		159764	Unit(s) _____	/ each
	20.4	Key switch surface-mounted with profile half cylinder, function 0 / 1 push-to-lock		306287	Unit(s) _____	/ each
	20.5	Key switch, surface-mounted, one-sided on / off push-to-lock contact with OPEN-CLOSE push button		306293	Unit(s) _____	/ each
	20.6	Key switch surface-mounted with profile half cylinder, function OPEN-CLOSE		159078	Unit(s) _____	/ each

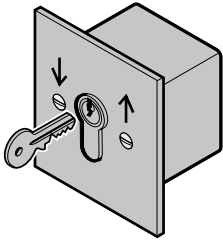

**Important:** The articles listed below are not identical to comparable articles in other Hörmann industrial price lists.  
Other optional extras on request

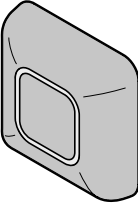
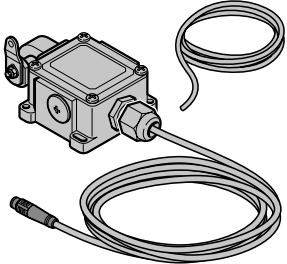
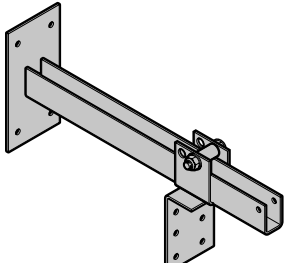
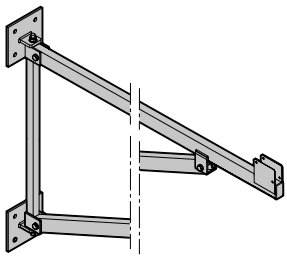
## 20. Accessories for operators and controls

Article	Item	Description	Production period	Art. no.	Quantity	€
	20.7	Key switch recessed with profile half cylinder, function OPEN-CLOSE		306284	Unit(s) _____	/ each
	20.8	Radar button HTR 1-24 (with volt-free output)		437393	Unit(s) _____	/ each
	20.9	Radar button Magic Switch surface-mounted Chroma		4982807	Unit(s) _____	/ each
	20.10	<b>Pull switch</b> With 15 m snap cable and 4 m cord with 4 m cord <b>Cord Ø 8 silver, length max. 4 m</b> (soft PVC) with eyelet and hook		4991969 159765 158868	Unit(s) _____ _____ _____	/ each / each / each
	20.11	<b>Cantilever arm</b> Galvanized steel 0.9 m Galvanized steel, ≤ 1.5 m, adjustable Galvanized steel, ≤ 3 m, adjustable Stainless steel, ≤ 3 m, adjustable		158996 306431 159681 159055	Unit(s) _____ _____ _____ _____	/ each / each / each / each
	20.12	<b>Cantilever arm</b> swivelling, 3°m		4991716	Unit(s) _____	/ each

**Important:** The articles listed below are not identical to comparable articles in other Hörmann industrial price lists. Other optional extras on request

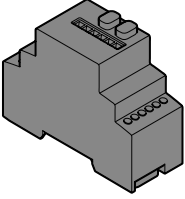
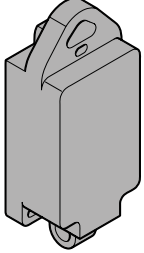
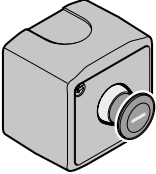
## 20. Accessories for operators and controls

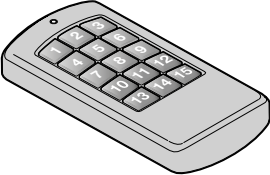
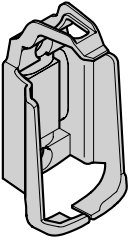
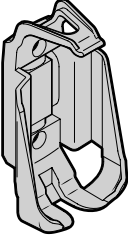
Article	Item Description	Production period	Art. no.	Quantity	€
	<b>20.13 Radio receiver, without battery, opening device</b> (1 x per door system required)		4982159	Unit(s) _____	/ each
	<b>20.14 Radio pull switch without battery</b> with 4 m cord		4982132	Unit(s) _____	/ each
	<b>20.15 Radio mushroom button in housing</b>		4982841	Unit(s) _____	/ each
	<b>20.16 Hand transmitter HSI 3 BiSecur</b>		635054	Unit(s) _____	/ each
	<b>20.17 Hand transmitter HSI 6 BiSecur</b>		4511801	Unit(s) _____	/ each
	<b>20.18 Hand transmitter HSI 15 BiSecur</b>		4511802	Unit(s) _____	/ each
	<b>20.19 Hand transmitter holder HSI 3 BS</b>		635059	Unit(s) _____	/ each
	<b>20.20 Hand transmitter holder HSI 6 BS</b>		437383	Unit(s) _____	/ each

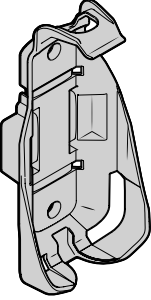
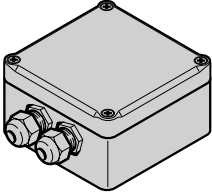
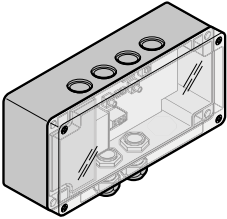
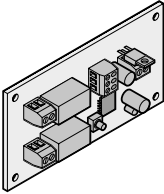
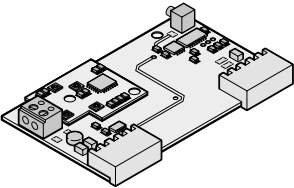
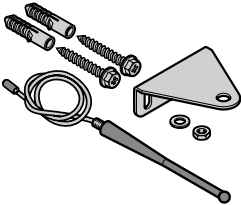
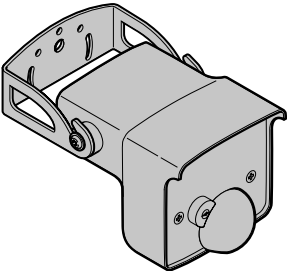

**Important:** The articles listed below are not identical to comparable articles in other Hörmann industrial price lists.  
Other optional extras on request

## 20. Accessories for operators and controls

Article	Item	Description	Production period	Art. no.	Quantity	€
	20.21	Hand transmitter holder HSI 15 BS		437384	Unit(s) _____	/ each
	20.22	Radio receiver HER 1 868.3 MHz 1 command (external)		437408	Unit(s) _____	/ each
	20.23	Radio receiver HER 1 868-BS		436724	Unit(s) _____	/ each
	20.24	Circuit board HET-E2 868-BS		4511819	Unit(s) _____	/ each
	20.25	Circuit board for radio receiver 868.3 MHz (internal, plug-in module)		157297	Unit(s) _____	/ each
	20.26	Antenna for signal amplification, 868.3 MHz		4980115	Unit(s) _____	/ each
	20.27	Radar movement detector Comfort Indoor functions: radar and presence, outdoor functions: radar Fitting height 3.5 – 6.0 m		4990602	Unit(s) _____	/ each

**Important:** The articles listed below are not identical to comparable articles in other Hörmann industrial price lists.  
Other optional extras on request

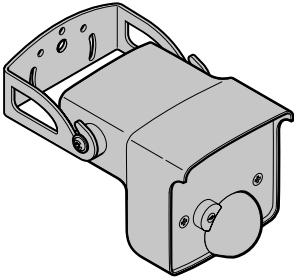
## 20. Accessories for operators and controls

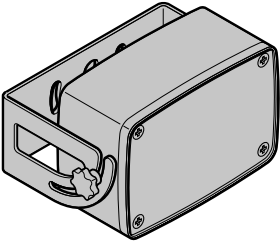
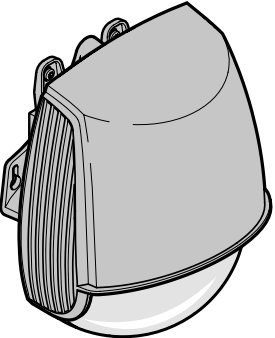
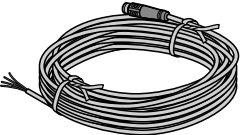
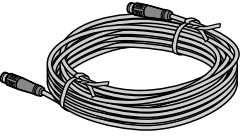
Article	Item Description	Production period	Art. no.	Quantity	€
	<b>20.28 Radar movement detector Comfort Mini</b> Fitting height 2.0 – 3.5 m		4991303	Unit(s) _____	/ each
	<b>20.29 Multi remote control opening device</b>		306428	Unit(s) _____	/ each
	<b>20.30 Radar movement detector MWD-C</b> Order connection cable separately.		4981104	Unit(s) _____	/ each
	<b>20.31 Scanprotect</b> Order connection cable separately.	01.01.2017 –	4991932	Unit(s) _____	/ each
	<b>20.32 Connection cable Snap 15 m</b> (for the 1st Scanprotect) Scanprotect / radar detector MWD-C	01.05.2017 –	4980462	Unit(s) _____	/ each
	<b>20.33 Connection cable</b> (from 2nd Scanprotect per door)  Snap 5 m Snap 10 m	01.05.2017 – 01.05.2017 –	4980463 4991895	Unit(s) _____ _____	/ each / each

**Important:** The articles listed below are not identical to comparable articles in other Hörmann industrial price lists.  
Other optional extras on request

# 20. Accessories for operators and controls

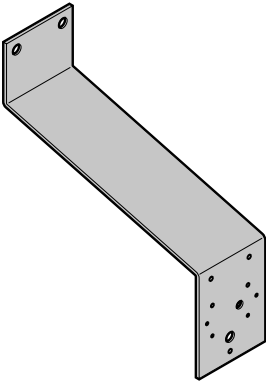
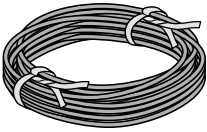
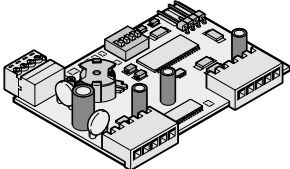
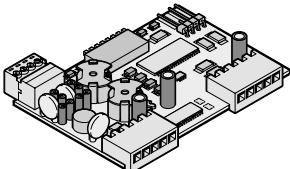
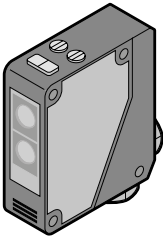
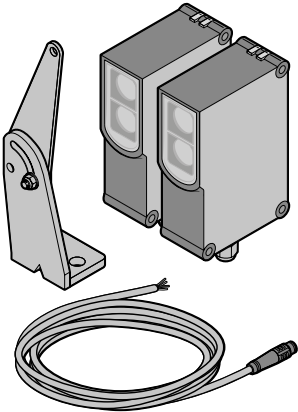
Article	Item	Description	Production period	Art. no.	Quantity	€
	<b>20.34</b>	<b>Opening device holder</b> 4 mm galvanized steel Dimensions: 83 × 520 × 140 mm		159059	Unit(s) _____	/ each
	<b>20.35</b>	<b>Loop wire</b> With 100 m connecting lead		159069	Unit(s) _____	/ each
	<b>20.36</b>	<b>Induction detector</b> <b>TST SUVEK, 1-channel</b> induction detector		157295	Unit(s) _____	/ each
	<b>20.37</b>	<b>Induction detector</b> <b>TST SUVEK, 2-channel</b> induction detector		157296	Unit(s) _____	/ each
	<b>20.38</b>	<b>Photocell with reflector, as a</b> <b>safety device</b>		159769	Unit(s) _____	/ each
	<b>20.39</b>	<b>Heatable photocell WS /</b> <b>WE27-2F450</b> complete with support bracket and reflector		159058	Unit(s) _____	/ each

**Important:** The articles listed below are not identical to comparable articles in other Hörmann industrial price lists.  
Other optional extras on request

## 20. Accessories for operators and controls

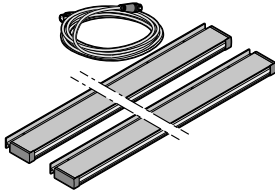
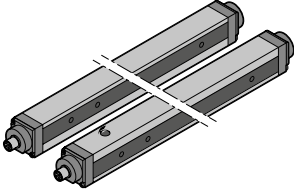
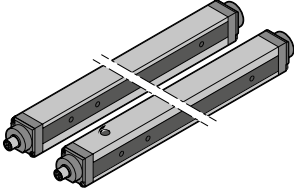
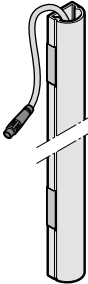
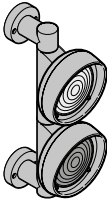
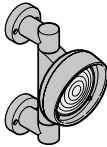
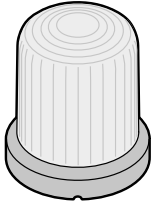
Article	Item Description	Production period	Art. no.	Quantity	€
	<b>20.40 Light grille ILG</b> 510 mm high, with 10 m cable		4990546	Unit(s) _____	/ each
	<b>20.41 Light grille ELG</b> 1490 mm high, crossed, beam distance 60 mm, cables 1 x 10 m and 1 x 15 m		159786	Unit(s) _____	/ each
	<b>20.42 Light grille</b> 2150 mm high, crossed, beam distance 60 mm, cables 1 x 10 m and 1 x 15 m		159065	Unit(s) _____	/ each
	<b>20.43 Traffic light LED light strip, illuminates in red / green / blue</b> 2000 mm long, IP 67		4981720	Unit(s) _____	/ each
	<b>20.44 Traffic light housing LED 230 V AC, red / green</b>		637537	Unit(s) _____	/ each
	<b>20.45 Traffic light housing LED 230 V AC</b>  red Green		637534 637535	Unit(s) _____ _____	/ each / each
	<b>20.46 Flashing warning light 230 V AC</b>  Orange red		159066 159782	Unit(s) _____ _____	/ each / each

**Important:** The articles listed below are not identical to comparable articles in other Hörmann industrial price lists.  
Other optional extras on request

## 20. Accessories for operators and controls

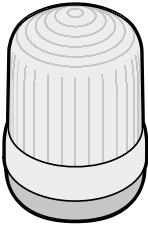
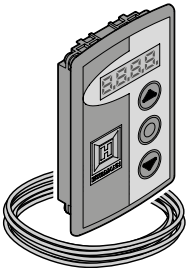
Article	Item Description	Production period	Art. no.	Quantity	€
	<b>20.47 Multi-function light</b>		159783 159067	Unit(s)	
	red Orange			_____	/ each / each
	<b>20.48 External control element</b> with connection circuit board and surface-mounted frame, cable 6.5 m		4991662	Unit(s) _____	/ each

**Important:** The articles listed below are not identical to comparable articles in other Hörmann industrial price lists.  
Other optional extras on request



# Brand quality for residential and commercial construction

The family-owned company Hörmann offers all important construction components for building and renovating projects from a single source. We manufacture in highly-specialised factories using the latest production technologies. Furthermore, our employees work intensively on new products, continual further developments and improvements to details. The results are patents and one-of-a-kind products you can depend on.

