

TDOKU 9006853-EN/11.2020

EN

Instructions for fitting, operating and maintenance

TGT rolling shutter

Table of contents

1	About these instructions.....	2
1.1	Intended use.....	2
1.2	Further applicable documents.....	2
1.3	Standards and directives to be observed	2
1.4	Warnings used.....	3
1.5	Symbols used.....	3
1.6	Abbreviations used.....	4
2	Basic safety instructions	4
2.1	Transportation.....	4
2.2	Fitting, testing and maintenance	4
2.3	Operation.....	5
3	Warranty	5
4	Fitting.....	5
4.1	Testing prior to fitting the door	5
4.2	Fitting dimensions	7
4.3	Fitting steps.....	7
4.4	Control system and control elements.....	39
5	Initial start-up.....	39
5.1	Spring tension	39
5.2	End-of-travel positions	39
5.3	Test run	39
6	Operation.....	39
6.1	Safety instructions for door operation.....	39
6.2	Emergency-OFF	40
6.3	Emergency operation in case of operator malfunction.....	40
6.4	Operating conditions	40
6.5	Wind load	40
6.6	Information on the product characteristics	40
7	Inspection and maintenance	41
7.1	Obligation to inspect and maintain.....	41
7.2	Malfunctions and damage remedy.....	41
7.3	Original spare parts	41
7.4	Tension springs and cables	41
7.5	Operator power	41
7.6	Storm damage.....	41
7.7	Inspection and maintenance plan	42
8	Cleaning and care.....	43
8.1	Door curtain.....	43
8.2	Safety equipment and photocells.....	43
9	Extension and conversion	43
10	Dismantling	43

1 About these instructions

Dear Customer,

We are delighted that you have decided to choose a Hörmann product.

These instructions are original operating instructions as outlined in the EC Directive 2006/42/EC. Read and follow these instructions carefully especially the section 2 *Basic safety instructions on page 4*. They provide you with important information on the safe fitting and operation, as well as proper care and maintenance, of your door system.

Competent operation and proper maintenance influence the performance and availability of your door system to a considerable degree. Operating errors and inadequate maintenance will lead to avoidable failures. Only competent operation and proper maintenance will guarantee satisfactory, long-term operational safety.

Should you have any questions on having read through these instructions, please feel free to consult our Customer Service.

1.1 Intended use

The TGT rolling shutter is only suitable for the following applications:

- Operation in industrial and commercial applications
- Closing passage openings
- Pedestrian and goods traffic
- Closing openings with a vertically guided door leaf

Using the door for purposes other than or exceeding those stated above is prohibited.

1.2 Further applicable documents

In addition to these instructions, please observe the following documents for individual accessories:

- Instructions for fitting, operating and service of the WA 300 R S4/WA 300 AR S4 operator
- Instructions for fitting additional electrical control elements
- Additional sheets for special components or special equipment

1.3 Standards and directives to be observed

1.3.1 Fitting and maintenance

At the least, observe the following European standards and directives, as well as all country-specific safety requirements, standards and regulations:

305/2011	Construction Products Regulation
2006/42/EC	Machinery Directive
2014/35/EU	Low Voltage Directive
2014/30/EU	Electromagnetic compatibility
EN 12453	Industrial, commercial and garage doors and gates – Safety in use of power operated doors – Requirements
EN 12604	Doors – Mechanical Aspects – Requirements
EN 12635	Doors – Fitting and Use

EN 13241	Industrial, commercial, garage doors and gates – Product standard – Part 1: Products without fire resistance or smoke control characteristics
EN ISO 13849-1 PL “c”, Cat. 2	Safety of machinery – Safety-related parts of control systems
EN 60335-1	Household and similar electrical appliances – Safety
DIN 4109-1	Sound insulation in buildings

For safety and health at work, observe at least the following rules and regulations or comparable national regulations, e.g.:

ASR A1.7	Power-Operated Windows and Doors
DGUV V3	General Regulations – Electrical Installations and Equipment

1.3.2 Operation





At the least, observe the following European standards, as well as country-specific safety requirements, standards and regulations.

EN 12453	Industrial, commercial and garage doors and gates – Safety in use of power operated doors – Requirements
----------	--

For safety and health at work, observe at least the following rules and regulations or comparable national regulations, e.g.:

ASR A1.7	Power-Operated Windows and Doors
DGUV V3	General Regulations – Electrical Installations and Equipment

1.4 Warnings used

ATTENTION	Indicates a danger that can lead to damage or destruction of the product .
	The general warning symbol indicates a danger that can lead to injury or death . In the text, the general warning symbol will be used in connection with the caution levels described below. In the illustrated section, an additional instruction refers back to the explanation in the text.
 CAUTION	Indicates a danger that can lead to minor or moderate injuries.
 WARNING	Indicates a danger that can lead to death or serious injuries.
 DANGER	Indicates a danger that can immediately lead to death or serious injuries.

1.5 Symbols used



Important note for avoiding damage to property



Correct arrangement or activity



Incorrect arrangement or activity



See text section



See illustrated section



See fitting dimension sheet



See separate fitting instructions for the control or for the additional electrical control elements

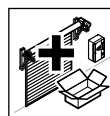

Optional components

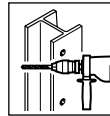

Drilling in steel



Welding on steel

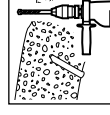

Drilling in concrete

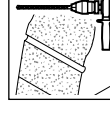

Drilling in brickwork

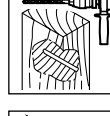

Drilling in timber



Remove and dispose of component or packaging



Inspect



Tighten the screws by hand



Plug-and-screw fitting: see information in the text

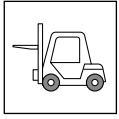

Use a suitable lifting device (e.g. forklift, crane)



Audible engagement

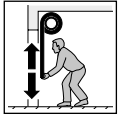

Manual door actuation

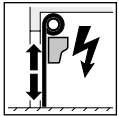

Door actuation via the operator



Operator engaged

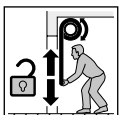

Operator disengaged

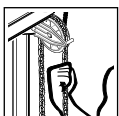

Actuation type: chain hoist

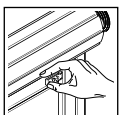

Actuation type: manual

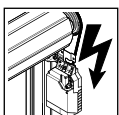

Actuation type: WA 300 R S4/WA 300 AR S4

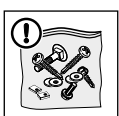

Use the provided fixing material

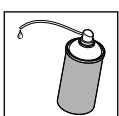

Use common lubrication oil



Lubricate



Straight bottom profile



Chamfered bottom profile



Danger: uncontrolled unrolling

1.6 Abbreviations used

EN	European standard
OFF	Finished floor level (FFL)

2 Basic safety instructions

Keep these instructions safe at the place of use together with all the door documentation.

WARNING

Incorrect fitting or incorrect handling

Incorrect fitting or handling of the door could result in serious injury.

- ▶ Follow all the instructions provided in this manual!

2.1 Transportation

ATTENTION

Transport of the door barrel without a special pallet

The door may be damaged if transported without a pallet.

- ▶ The door barrel must only ever be transported on the special pallet.

2.2 Fitting, testing and maintenance

Fitting, testing and maintenance may only be carried out by a specialist. According to EN 12635, a specialist is a person with suitable training, specialist knowledge and practical experience sufficient to correctly and safely fit, test, and carry out maintenance on a door system.

- For your own safety, have the product installed by an approved specialist company.
- Do not alter or remove any functional parts! You otherwise risk putting important safety components out of action.
- Always obtain the permission of the structural engineer before fastening the door system to supporting structural elements.
- Throughout fitting, protect the door system components, especially the door curtain, against dirt and damage.
- Make sure that whenever checks, maintenance work and cleaning are being carried out, the door system cannot be actuated by other persons.

 WARNING
Changes to the door construction Additional components could overload the door construction and lead to serious injuries. ▶ Do not attach any additional components.

2.3 Operation

- The door system may only be operated by persons who have been instructed in its proper use. Instruction is provided by the fitting personnel following the initial start-up procedures.
- The door system opens and closes vertically upwards and downwards. When operating the door, make sure that neither persons – children in particular – nor objects are located within the door’s area of travel.

 WARNING
Defective door systems A fault in the door system can lead to serious injuries. ▶ Only ever use the door system when it is technically sound and in perfect working order.

 WARNING
Missing or incomplete trap guard A missing or incomplete trap guard can lead to serious injuries. ▶ Only use the door system when the original trap guard PVTGT or a technically equivalent guard is installed on the door system.

3 Warranty

For the warranty, the generally recognised terms and conditions or those agreed in the delivery contract apply. The warranty will no longer apply under the following conditions:

- You damage the door due to a lack of knowledge of the information provided in these Instructions for Fitting, Operating and Maintenance.
- You carry out structural modifications without our prior approval.
- You undertake improper installation or arrange for same to be carried out by others, contrary to the installation guidelines we have set out.
- You damage the door due to improper operation (see 6 *Operation on page 39*).
- You are using the door for purposes for which it was not intended (see 1.1 *Intended use on page 2*).
- You fail to have the door inspected and maintained at regular intervals as stipulated (see 7.1 *Obligation to inspect and maintain on page 41*).

4 Fitting

NOTES:

Take note of the following documents:

- Enclosed additional sheets for special components or special equipment as well as the table of fitting dimensions
- Notes on fitting in 2 *Basic safety instructions on page 4*
- The fitting and operating safety requirements as described in 1.3 *Standards and directives to be observed on page 2*

All specified dimensions in the illustrated section are in [mm].

4.1 Testing prior to fitting the door

4.1.1 Prerequisites for the building structure

Only fit the door under the following prerequisites:

- There is a second exit in the room where the door is to be fitted.
- A water run-off has been installed outside in front of the bottom seal.
- A metre line is present.
- The hall floor is finished.
- The building structure is level (tolerance ± 5 mm).

4.1.2 Minimum requirements for the building structure

- Concrete
 - Strength class C 20/25
 - Thickness 140 mm
 - Standard EN 206-1
- Steel
 - Strength class S235-JRG2
 - Thickness 5 mm
 - Standard EN 10027-1
- Brickwork
 - Strength class 12 / mortar group II
 - Thickness 240 mm
 - Standard DIN 1053-1
- Timber
 - Coniferous wood C24/quality category II
 - Thickness 120 mm
 - Standard DIN 1052 (EC5)

4.1.3 Test dimensions

p1	Clear width of the building opening
p2	Clear height of the building opening
p3	Min. sideroom for support bracket on left
p4	Min. sideroom for side guide on left
p5	Min. sideroom for support bracket on right
p6	Min. sideroom for side guide on right
p7	Min. headroom
p8	Min. overall fitting depth
p9	Bottom support bracket dimension on left
p10	Bottom support bracket dimension on right
p11	Ordering size: door width
p12	Ordering size: door height
p13	Available sideroom on left

p14	Available sideroom on right
p15	Available headroom

Curtain cover

pv0.00	Total width of curtain cover
pv0.01	Fitting depth of curtain cover
pv1.00	FFL to top edge of barrel casing support bracket
pv1.01	Centre of door to outer edge of curtain cover on operator side
pv1.02	Centre of door to outer edge of curtain cover on bearing side
pv1.03	Distance from outer edge of curtain cover to centre of centre support bracket or distance from centre of centre support bracket to centre of centre support bracket
pv1.04	FFL to bottom edge of operator cover

4.1.4 Door components

Check the following points before fitting:

- The delivery is complete.
- All the components are damage-free.

4.1.5 Fixing points

 WARNING
Danger of damage and falling if the specified fixing points are not used
<ul style="list-style-type: none"> ▶ Fix the door system at all of the fixing points specified in these instructions and the table of fitting dimensions. ▶ Do not deviate from the tolerances specified in the table of fitting dimensions for the fixing point positions.

4.1.6 Fixing material

 WARNING
Danger of damage and falling when unsuitable fixing material is used
<ul style="list-style-type: none"> ▶ The fitter must check the suitability of the provided fixing material for use in the intended fitting location; other fixing material must be used if the provided fixing material is suitable for concrete (≥ B15), but is not officially approved. ▶ If used as an external rolling shutter or in car wash halls, only use stainless steel fixing material to fix the support brackets. ▶ When fastening the door system to a building structure made of gas concrete, always provide a subframe of steel posts.

NOTES:

- Check whether the fixing material intended for use with the existing building structure have been included / are available.
- Only use the fixing material listed in the following table.

Support brackets

Steel	DIN 933 M8 × 40 A4
	DIN 9021-8.4 A4
	DIN 9021-8.4 KS
	DIN 934-8-A4
Concrete/brickwork	LK 10 × 80 T40
	Würth Shark Pro 12
Timber	LK 10 × 80 T40

Side guides

Steel	DIN 7981C-T30 6.3 × 80
Concrete/brickwork	LK 6 × 100 T30
	Würth W-RD 8 × 30/100
Timber	Hörmann LK 6 × 100 T30

Plug-and-screw fitting

NOTES:

Only fit the plugs under the following prerequisites:

- The building structure is at least 30 mm thicker than the depth of the drill hole.
- The edge distance from the drill hole to the building structure edge is at least 50 mm.

Only use new plug sleeves.

Procedure:

1. Drill the hole at a right angle to the surface.
2. Remove the drilling dust from the drill hole.
3. Insert the plug sleeve into the drill hole by lightly hammering in with a mason's mallet until the collar is flush with the building structure or structural component.
4. Tighten the screw until the component is firmly fastened to the building structure.
The following conditions must be met:
 - It must be difficult to turn the screw further.
 - The plug sleeve must not turn with the screw.

4.1.7 Security bolts

 WARNING
Danger of falling when fitting the curtain if there are no security bolts in the side guides
Damage to the door system and serious injuries may occur if the door curtain is inserted in the side guides and the security bolts are not fitted.
<ul style="list-style-type: none"> ▶ Only insert the door curtain in the side guides if the security bolts have been fitted to each side guide. ▶ Only remove the bolts after the spring assemblies have been fitted.

4.1.8 Door springs

 WARNING
<p>Door springs Damage to the door system and serious injuries may occur if the door springs are fitted incorrectly.</p> <ul style="list-style-type: none"> ▶ Only fit the springs if the door curtain is in the Open end-of-travel position and the grip handles have been fitted to the bottom profile and the security bolts have been fitted in the side guides.

4.1.9 Protective foiling

ATTENTION
<p>Malfunction due to protective foiling</p> <ul style="list-style-type: none"> ▶ Remove the protective foiling applied at the factory from all door components before fitting.

4.1.10 Fitting aids

NOTE:

Use suitable tools and appropriate equipment for fitting the door system.

Have the following aids ready:

- A suitable lifting device (forklift, hand lift) to position the door system against the building structure.
- A suitable lifting platform or scaffold

4.1.11 Additional door components

Before fitting the door, install the following components (if provided):

- Additional posts
- Weld-on plates
- Fascia panel

During fitting, observe the data stated in the following documents:

- Fitting dimension sheet
- Additional sheets

4.2 Fitting dimensions

m1.00	Reference plane finished floor level (FFL)
m1.01	Door width
m1.02	Door height
m1.03	Centre of door to operator support bracket fixing point
m1.04	Centre of door to bearing support bracket fixing point
m1.05	FFL to top operator support bracket fixing point
m1.06	FFL to top bearing support bracket fixing point
m1.07	Lintel to centre of barrel
m1.08	Support height
m1.09	Reveal to back edge of side guides
m1.10	Back edge of side guide on right to back edge of side guide on left
m1.11	FFL to bottommost fixing point of side guide

m1.12	Distance between side guide fixing points
m1.13	Bottom edge of lintel to bottom edge of lintel seal locating profile
m1.15	FFL to bottom operator support bracket fixing point
m1.16	FFL to bottom bearing support bracket fixing point
m1.17	Reveal to side guide fixing point
m1.18	FFL to centre of barrel
m1.19	Distance of top side guide fixing point
m2.00	Additional post width
m2.01	Additional post height
m3.00	Fascia panel height
m4.00	FFL to bottom edge of weld-on plate on operator side
m4.01	FFL to bottom edge of weld-on plate on bearing side
m4.02	Reveal to inside edge of weld-on plate on operator side
m4.03	Reveal to inside edge of weld-on plate on bearing side
m4.04	Weld-on plate width
m4.05	Weld-on plate height

4.3 Fitting steps

Fit the door system using the following illustrations.

- Proceed carefully step by step.
- Observe all additional notes given.

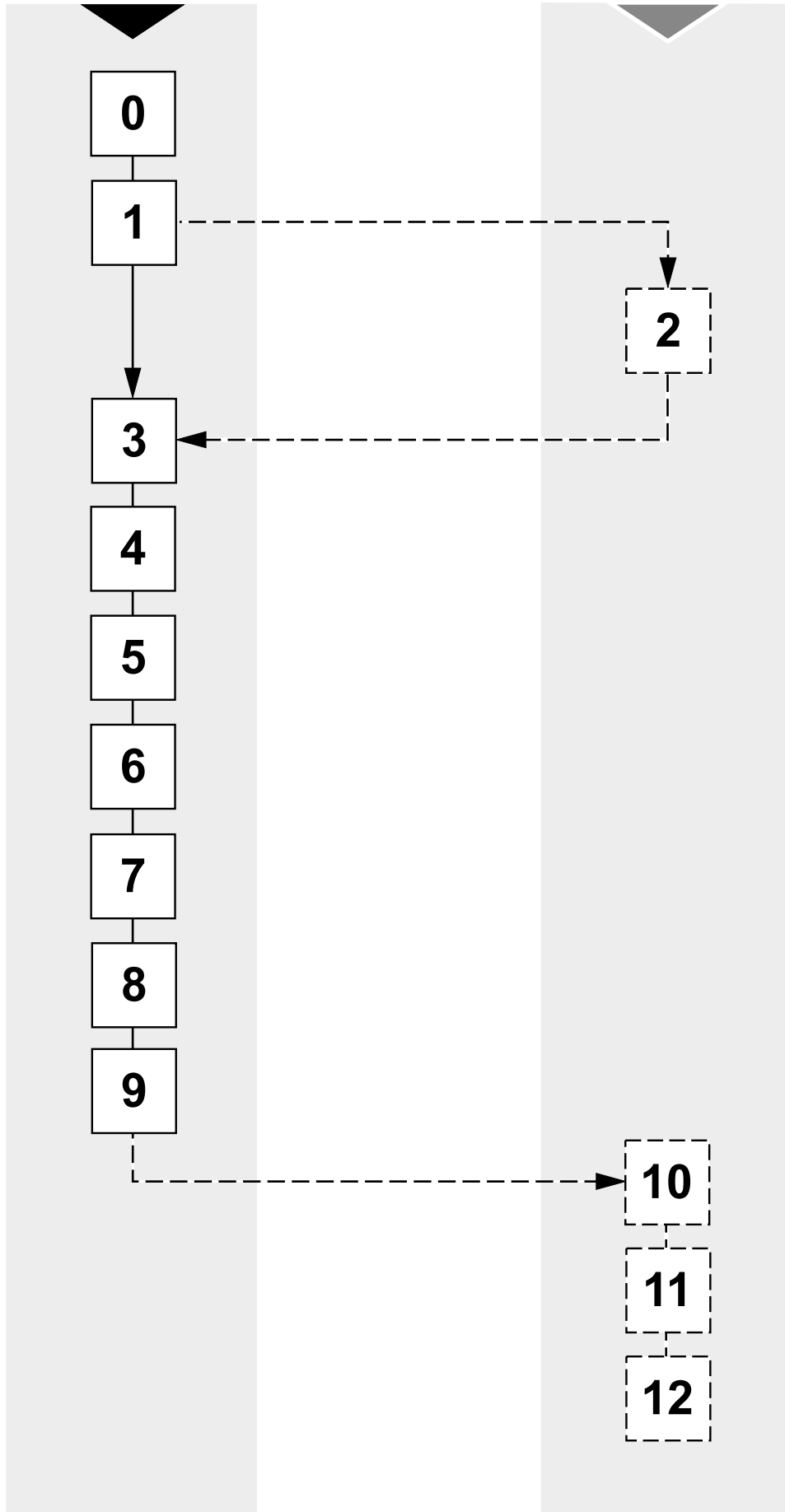
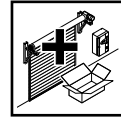
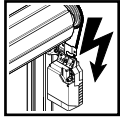

0

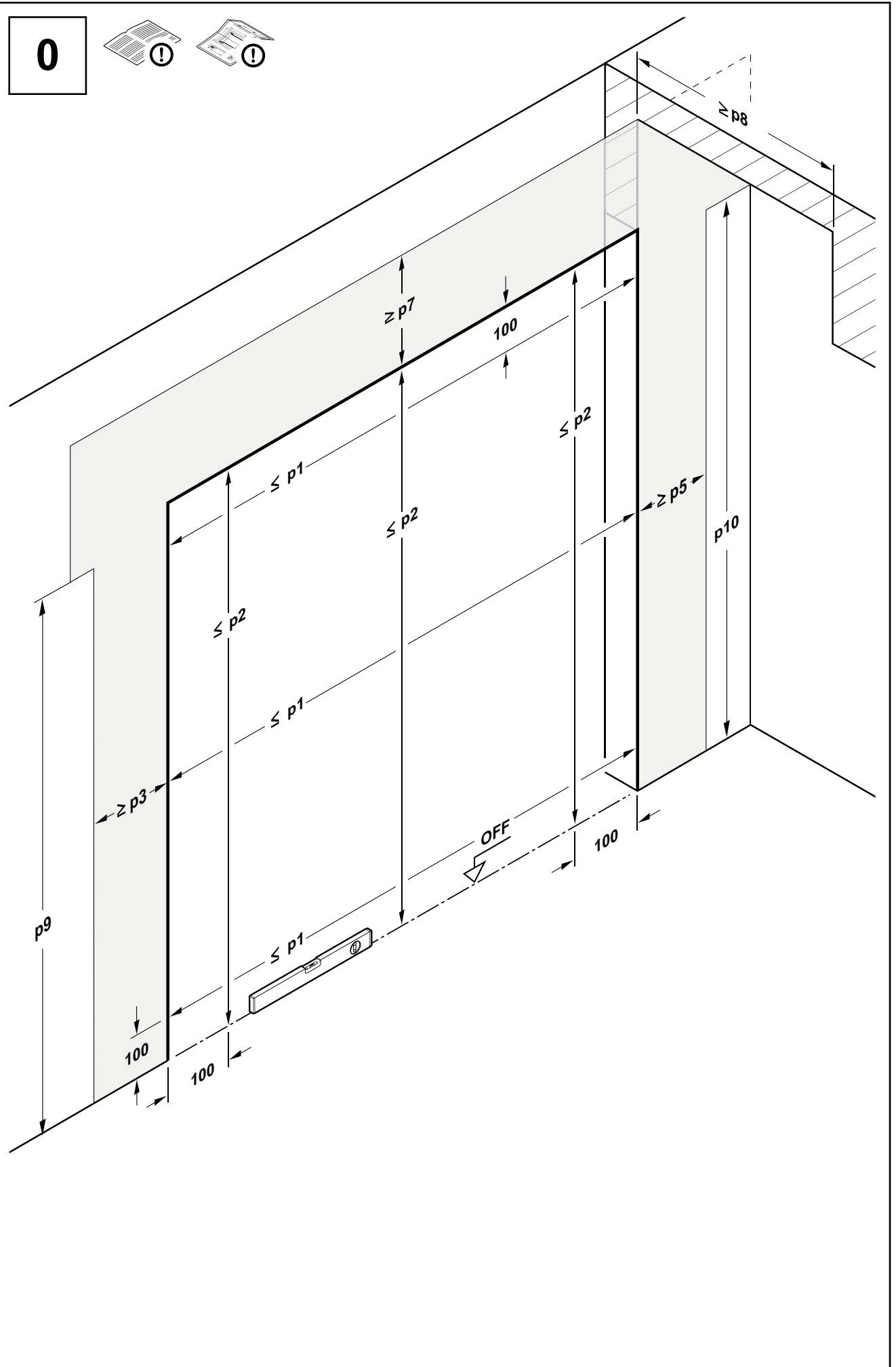

1

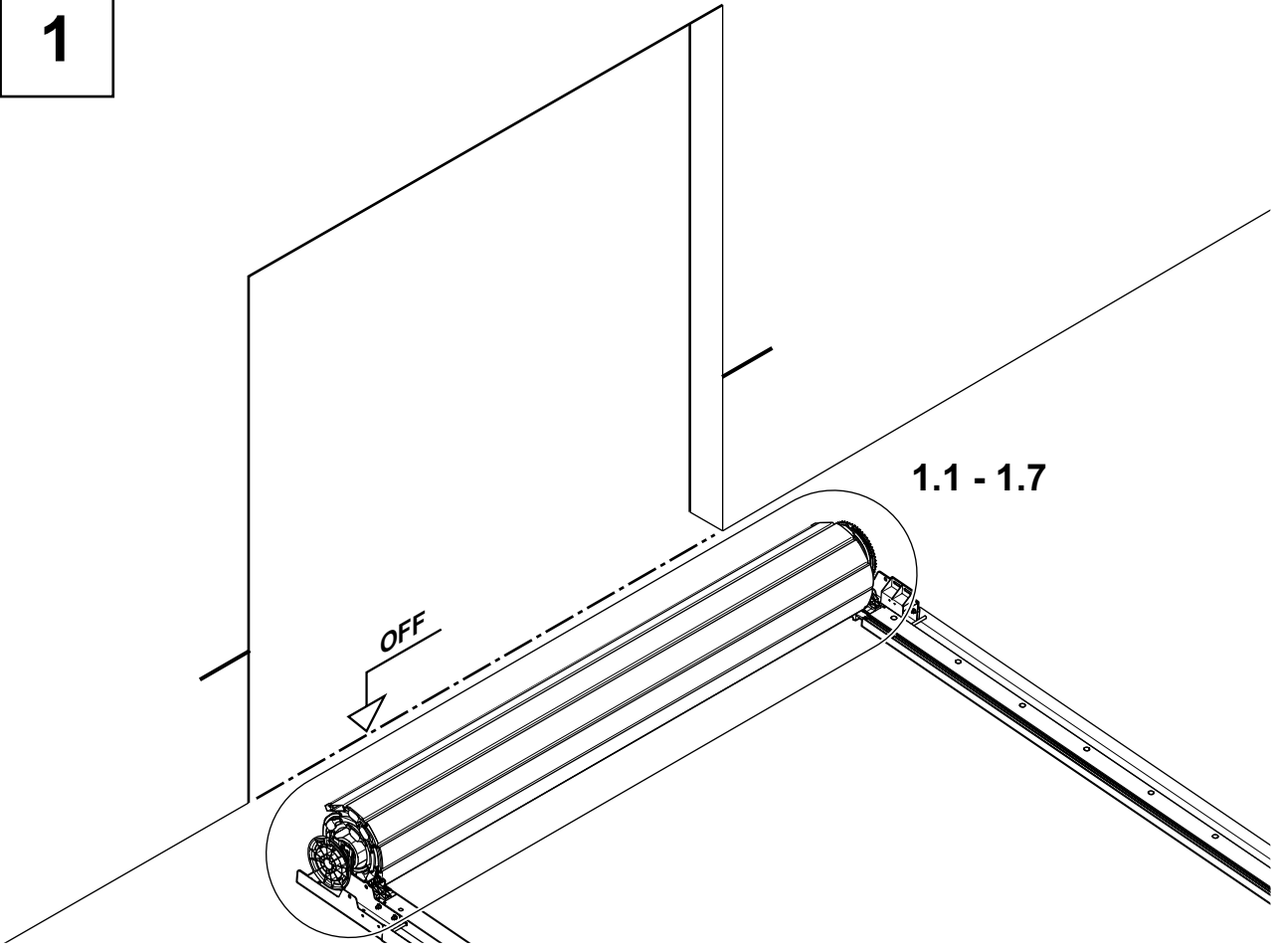

1.1

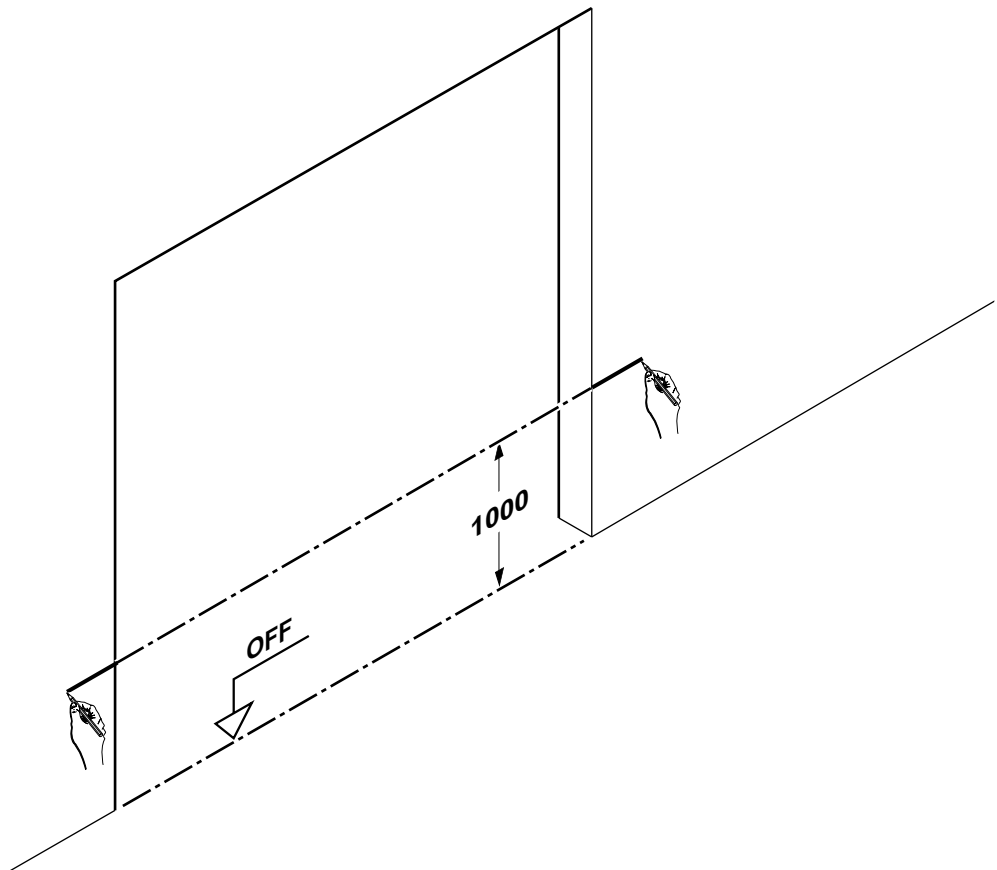

1.2

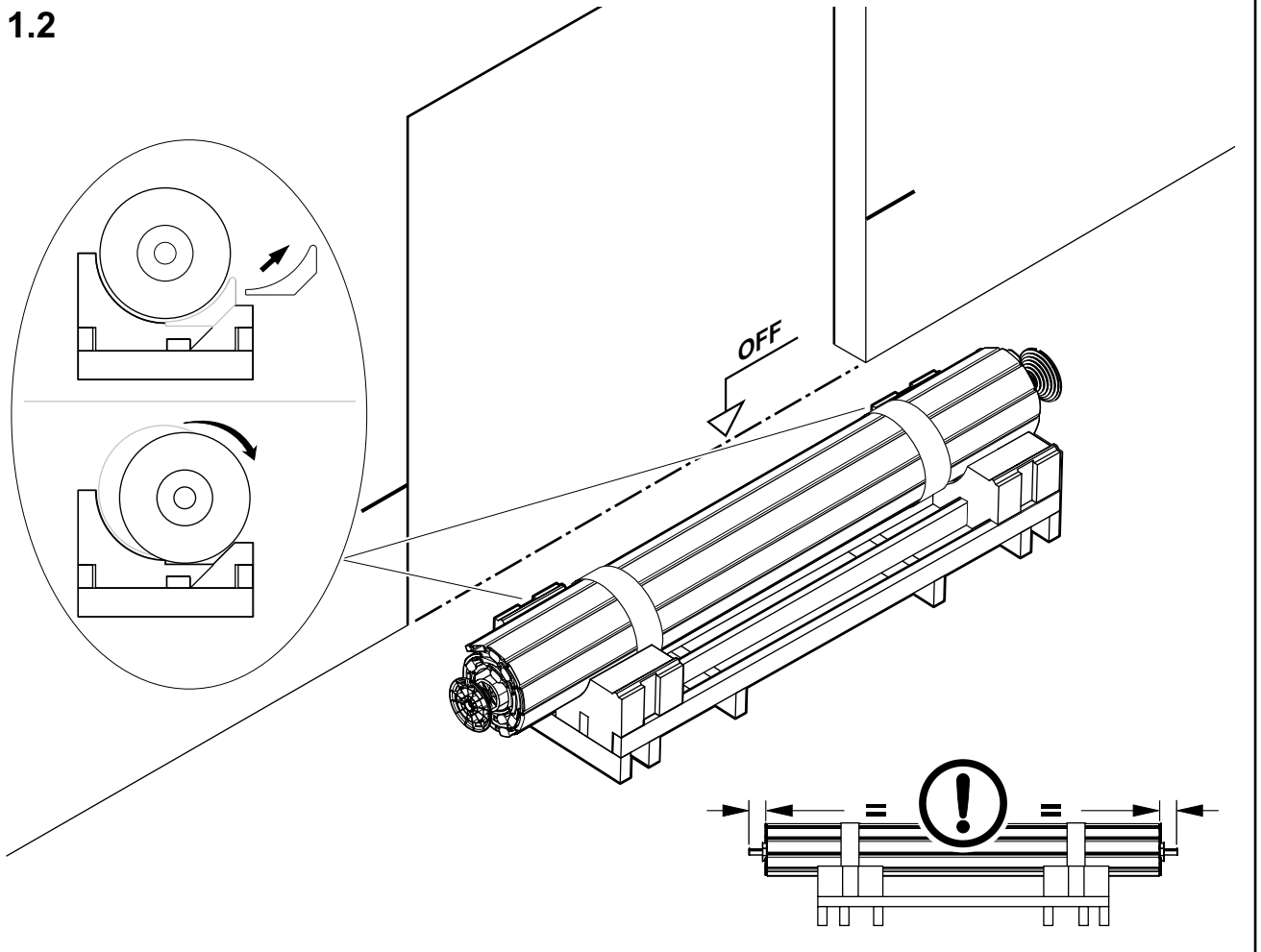

1.3

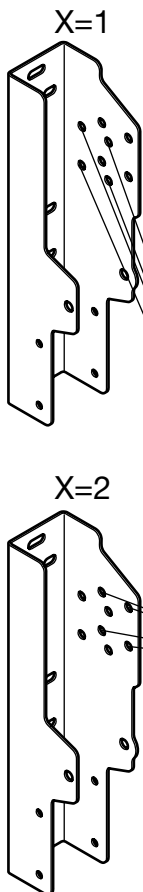

CE	
0757	
Hörmann KG Verkaufsgesellschaft Upheider Weg 94-98 33803 Steinhagen	
17	
www.hoermann.com/dop	
EN 13241:2003+A2:2016	
Verwendungszweck(e):	
für deklarierte spezielle Zwecke und/oder sonstige Zwecke, für die spezielle Anforderungen, insbesondere an Lärm, Energie, Dichtheit und Nutzungssicherheit gelten.	
Widerstand gegen Windlast	Klasse <input type="text"/>
Wärmewiderstand	W/(m²K) <input type="text"/>
Auftrags-Nr. <input type="text"/>	
Pos.-Nr. <input type="text"/>	Tor-Nr. <input type="text"/>
Tortyp <input type="text"/>	Baujahr <input type="text"/>
Behang <input type="text"/>	
Größe [mm] <input type="text"/>	Gewicht [kg] <input type="text"/>
Wellenposition <input type="text" value="X"/>	
Feder links <input type="text"/>	Feder rechts <input type="text"/>
Seil <input type="text"/>	Einhakpunkt <input type="text"/>
SKS für Impulsbetrieb erforderlich	
ja <input type="text"/>	nein <input type="text"/>

1.4

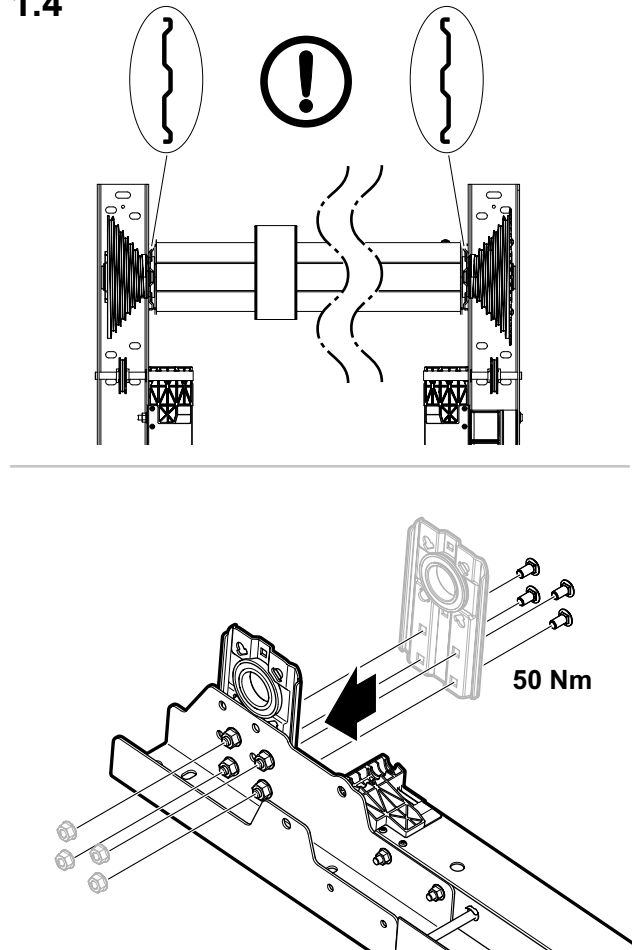

1.5

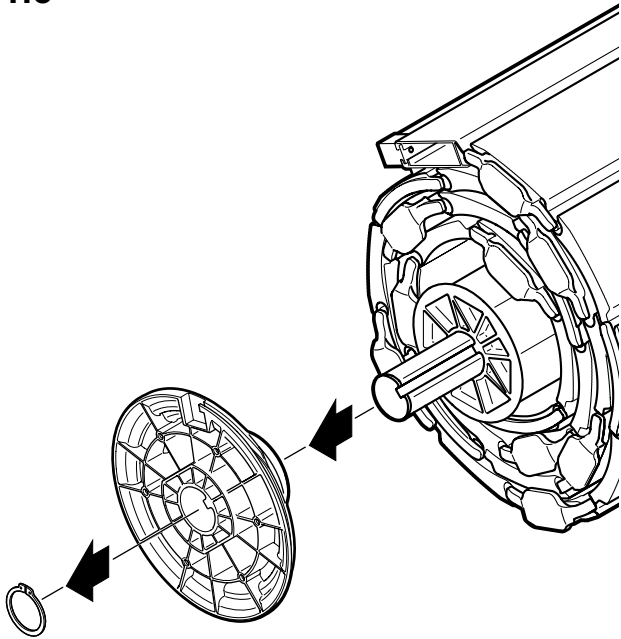

1

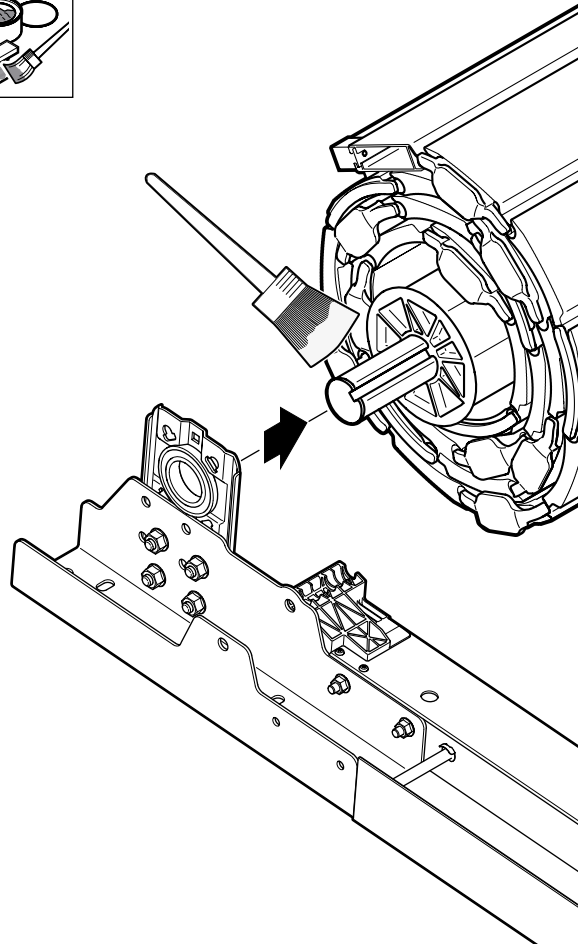

2

1.6

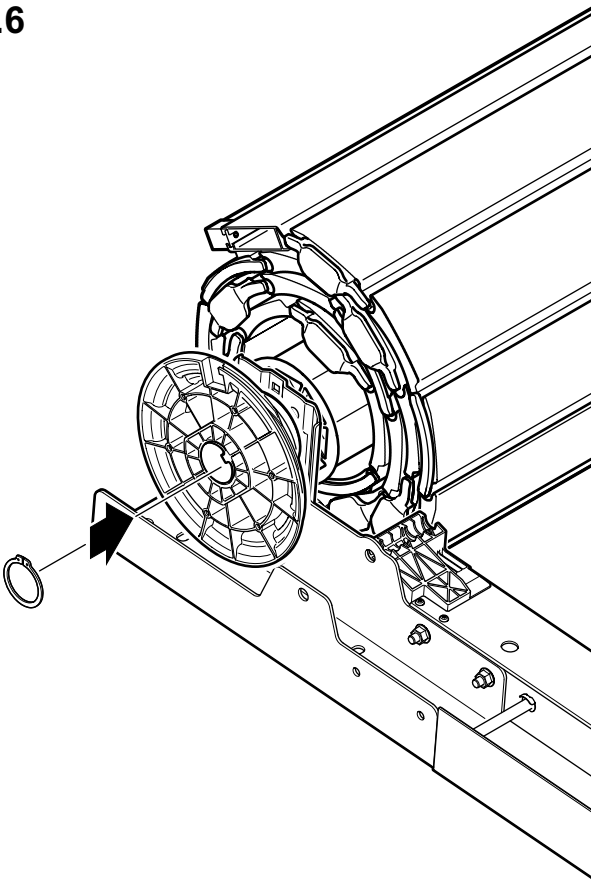

1.7

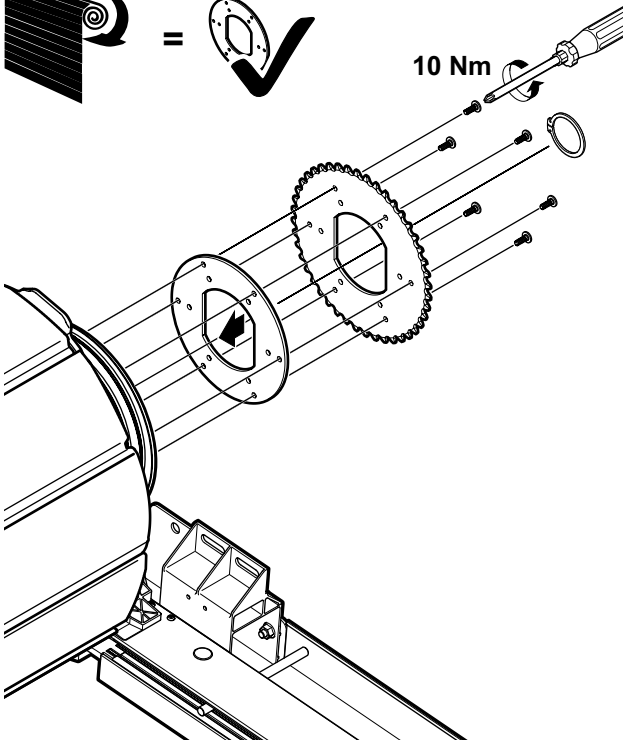
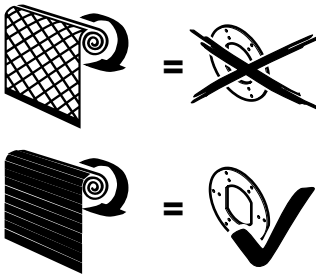

2.1

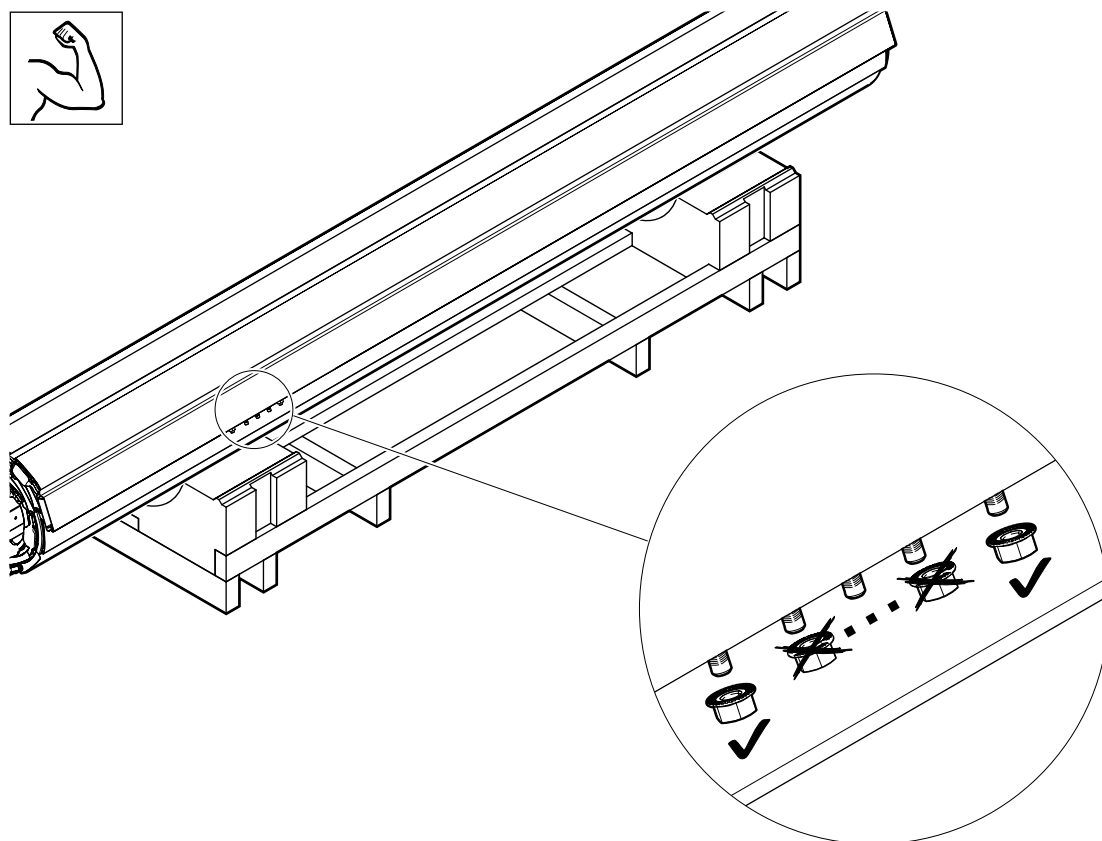
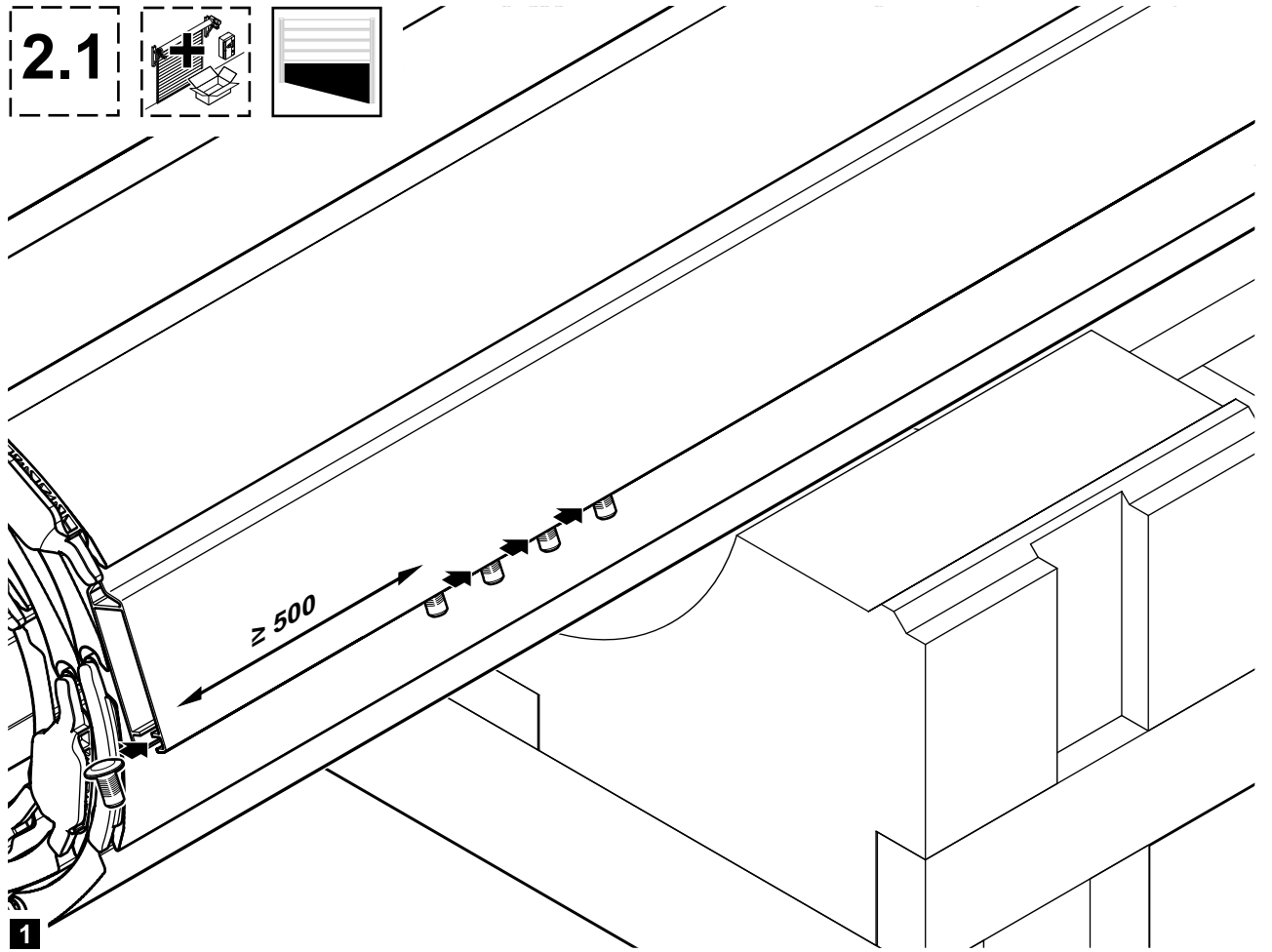

2.2

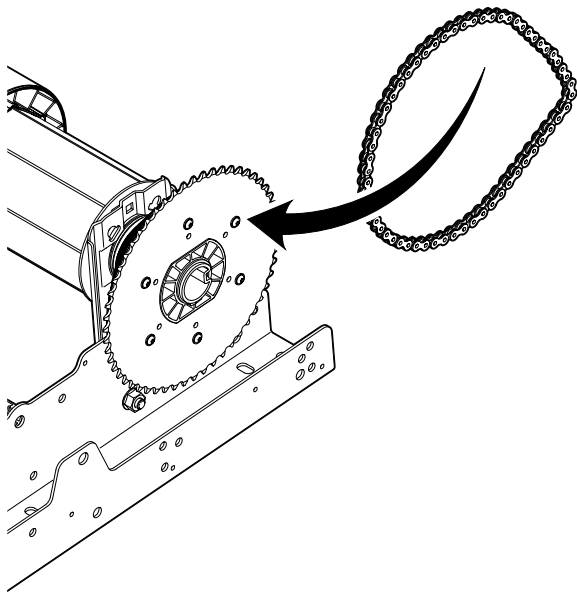

1

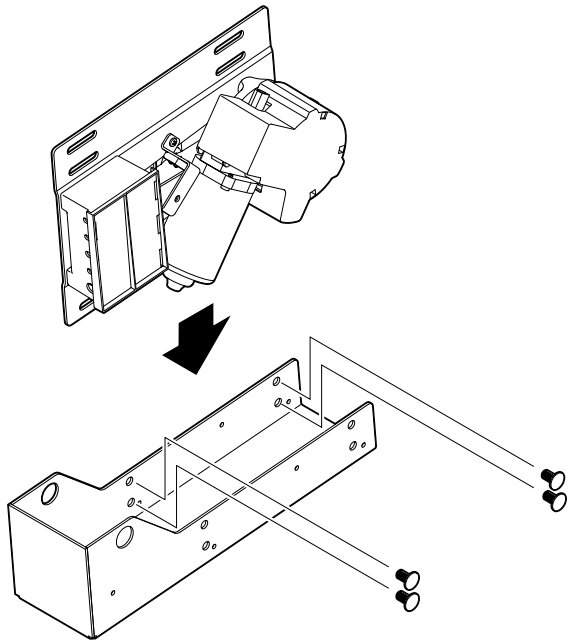

2

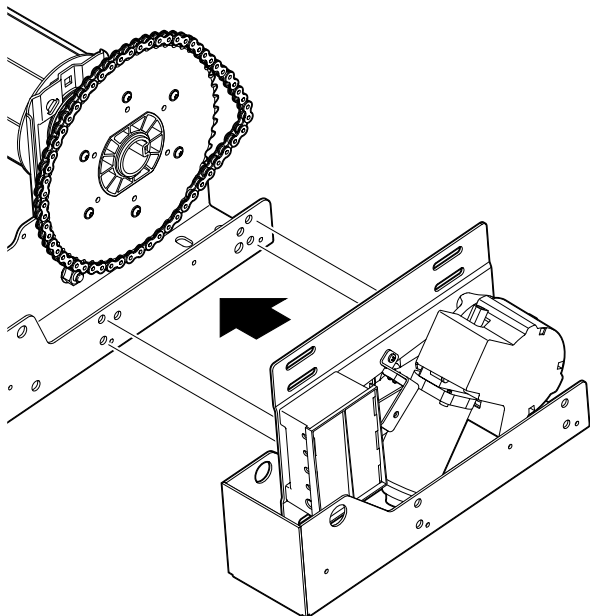

3

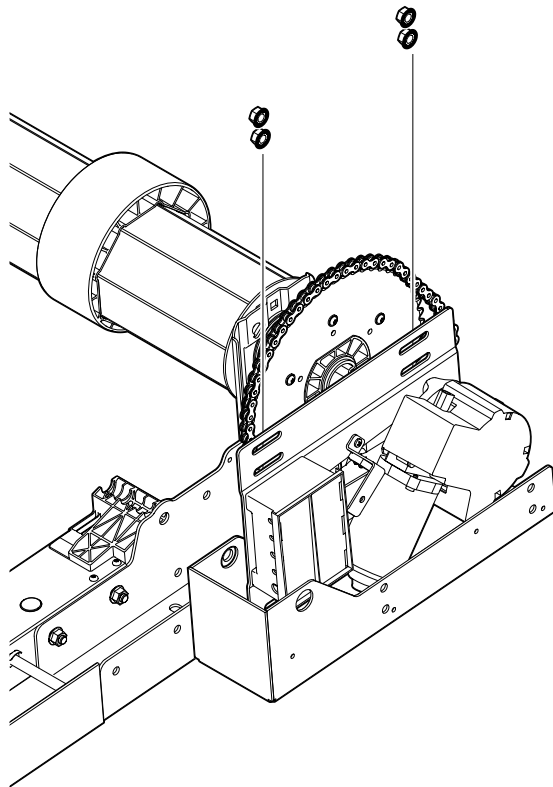

4

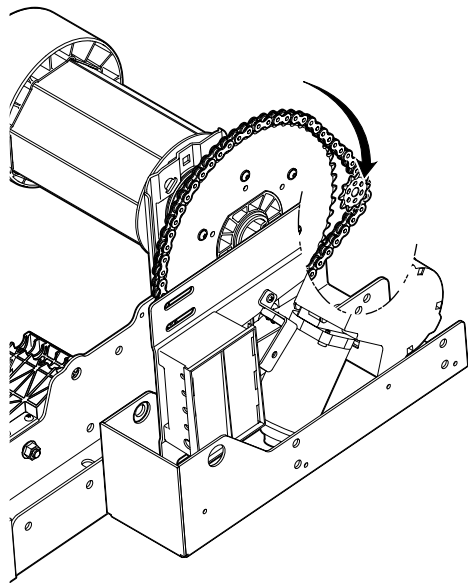

5

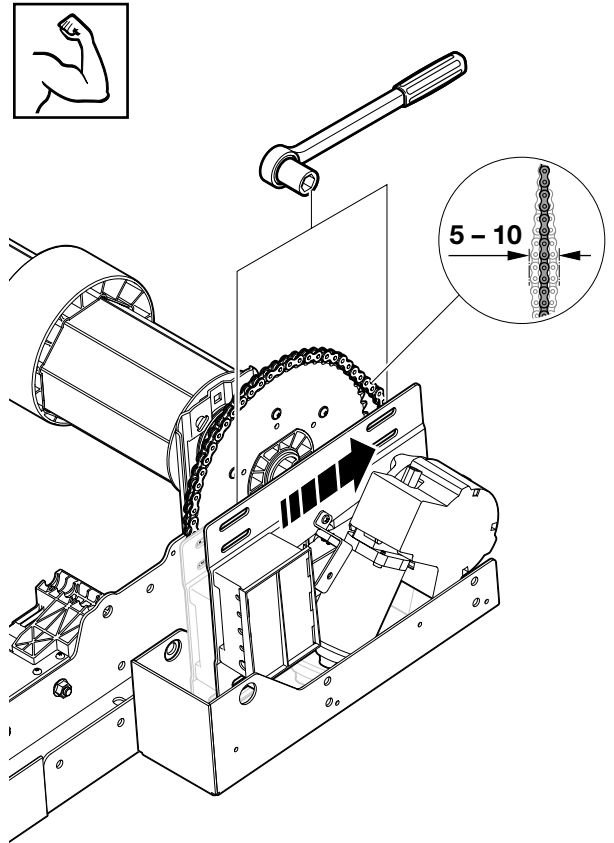

6

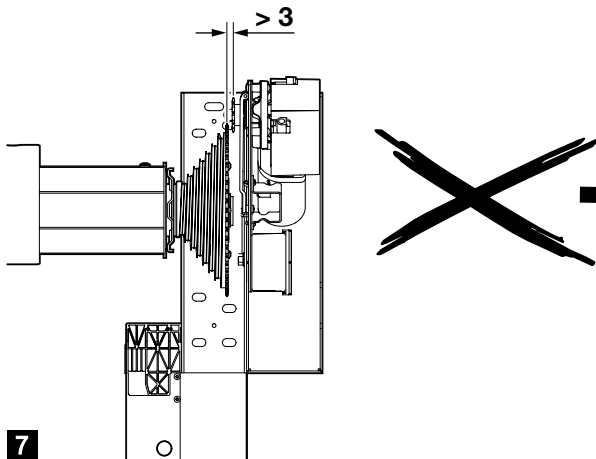
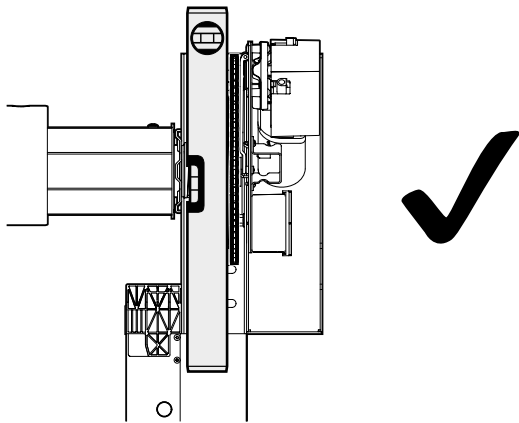

7

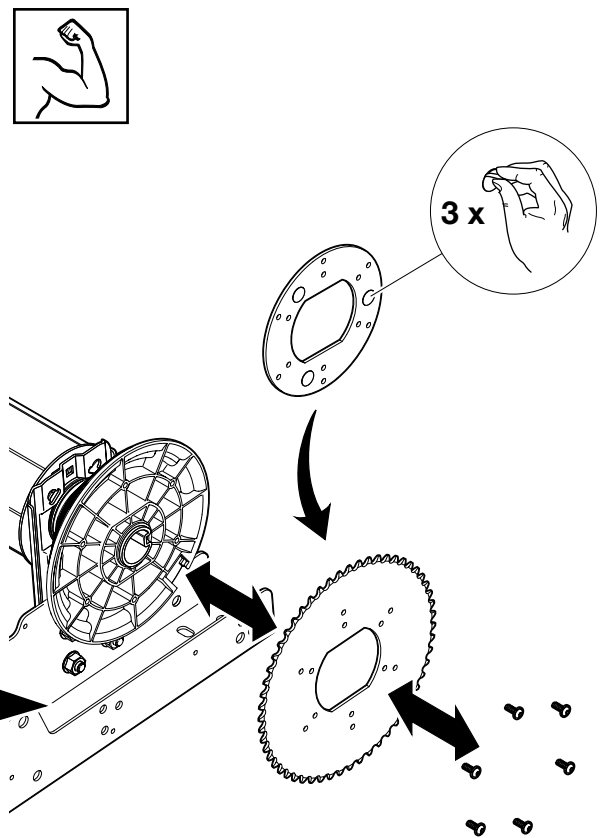

2.3

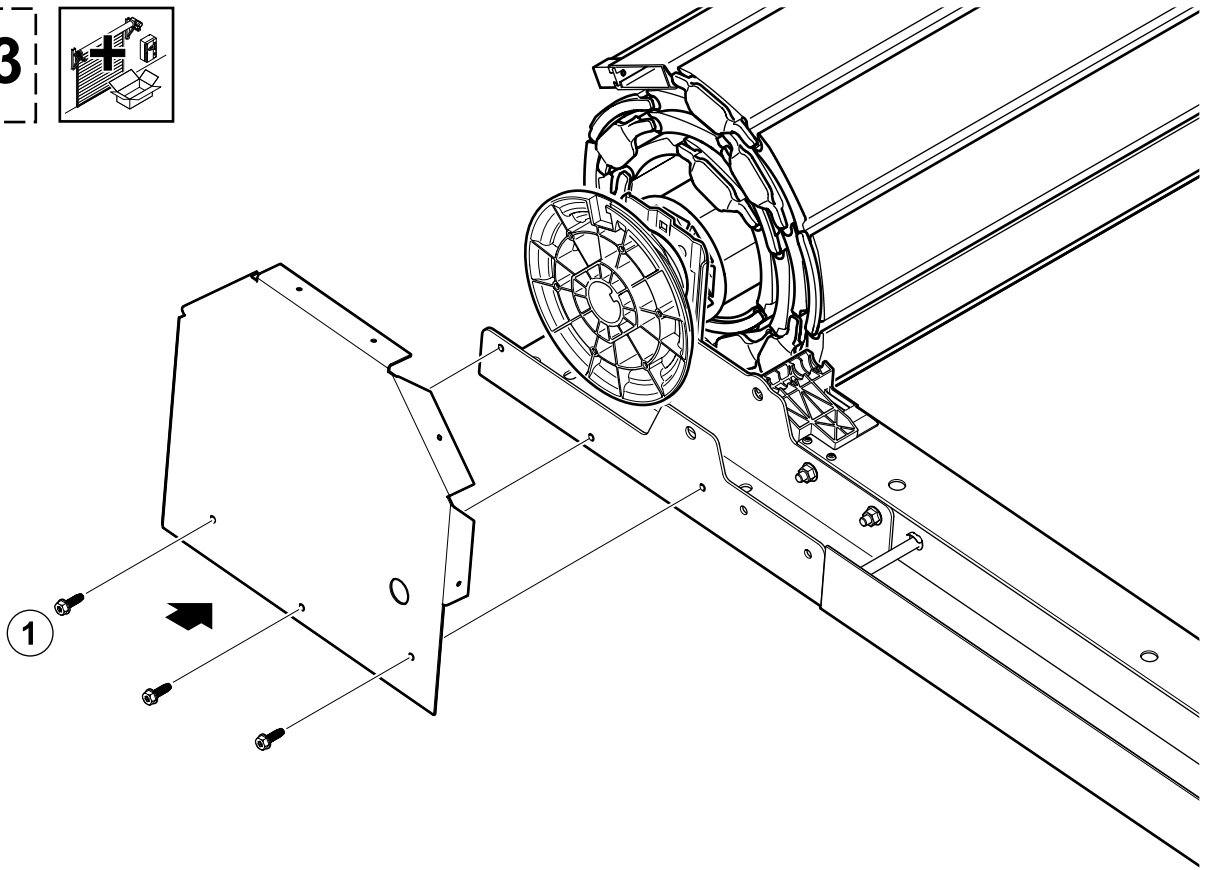

1

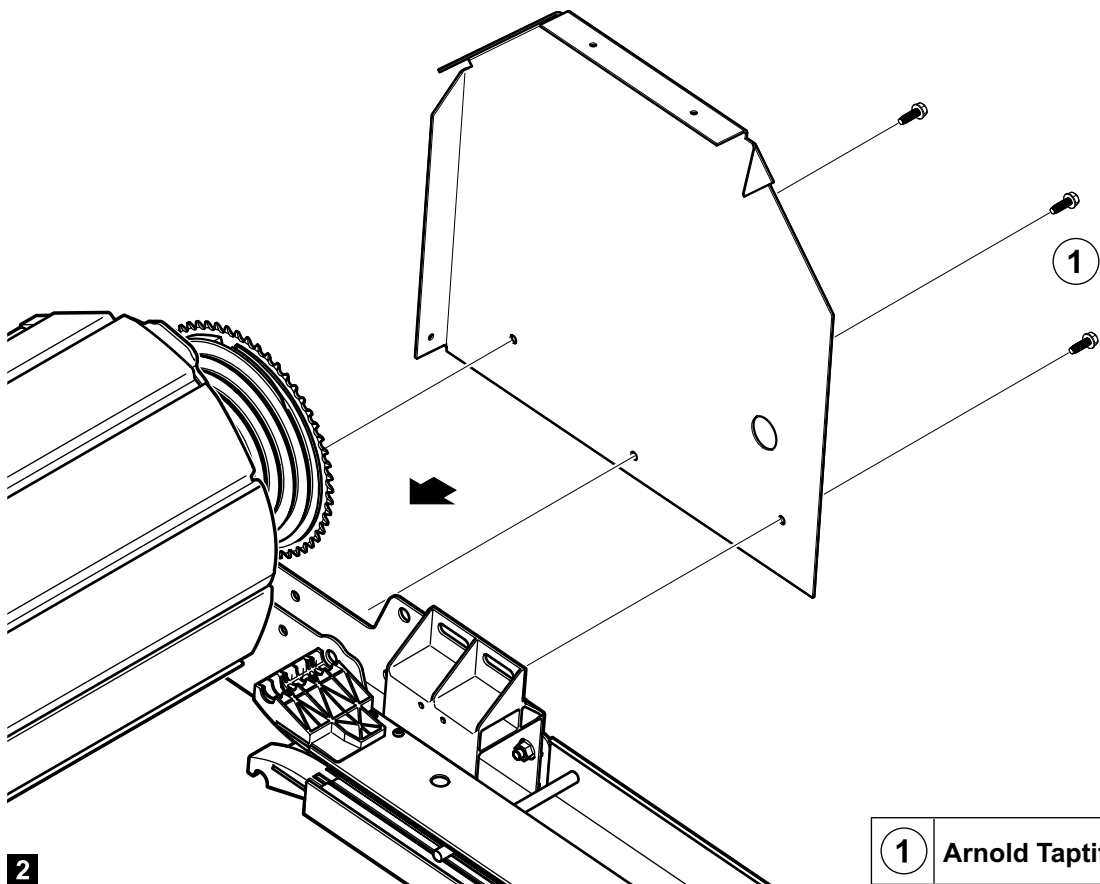

2

1 Arnold Tapite M5 x 16

3

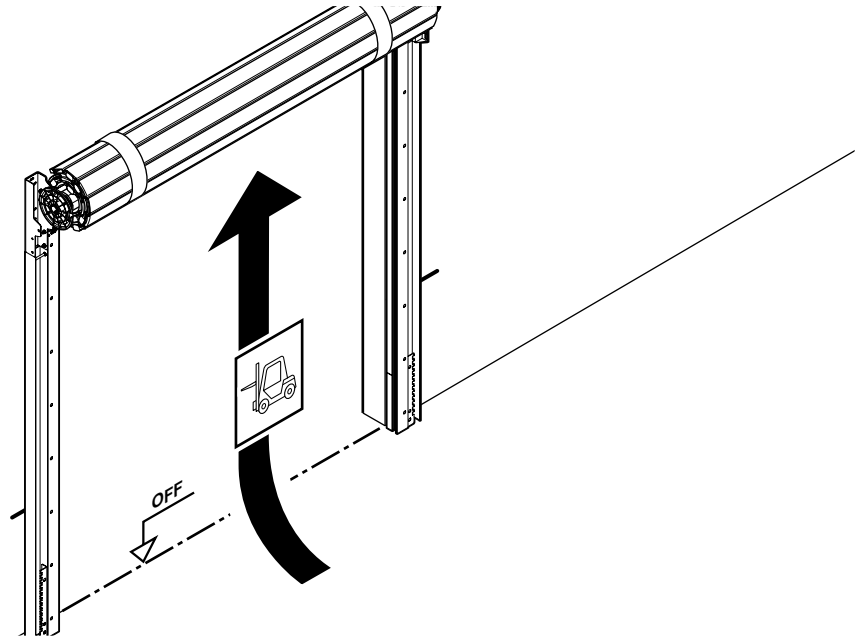

3.1

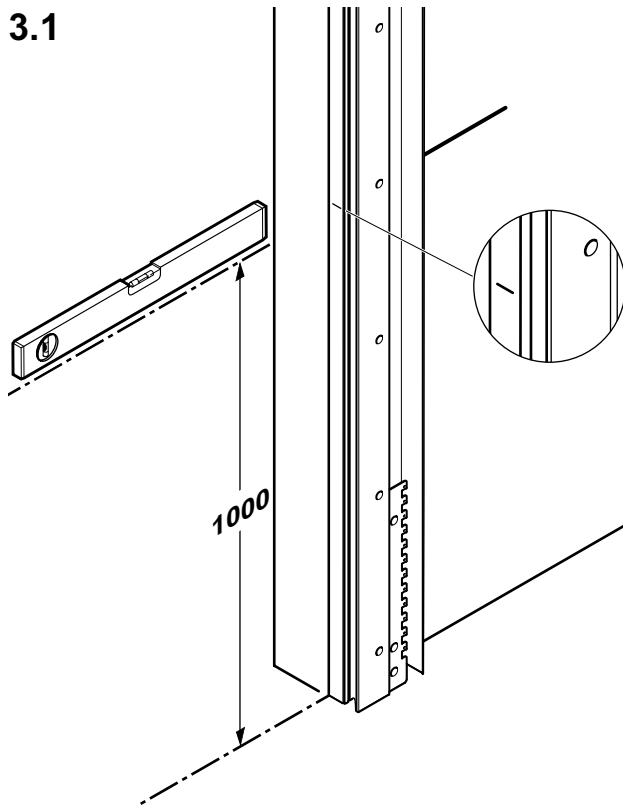

3.2

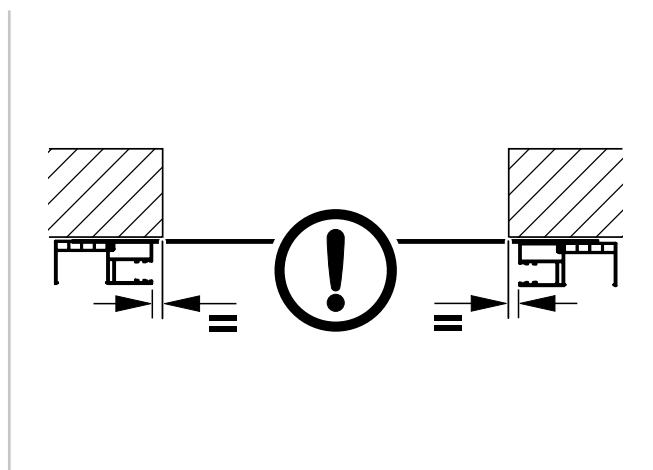
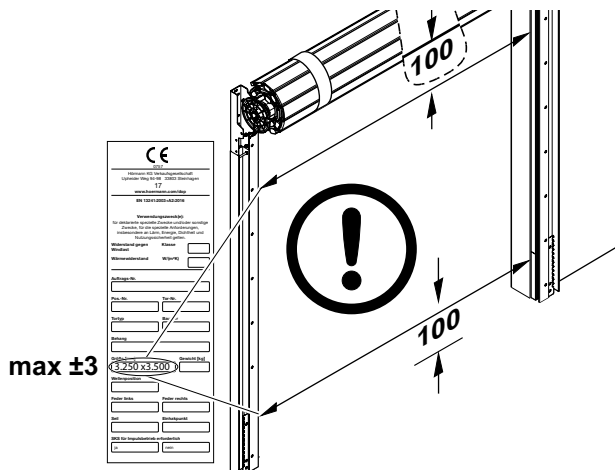
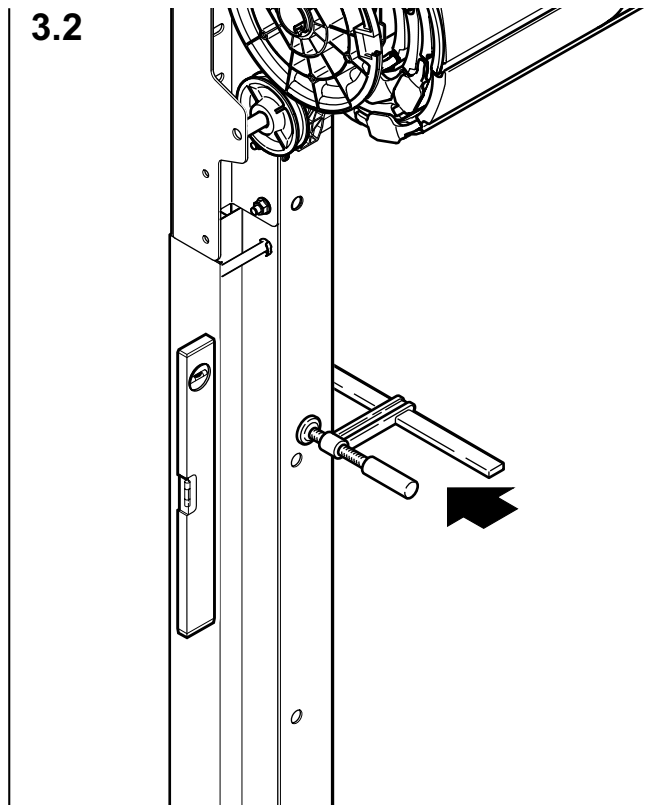

3.3a

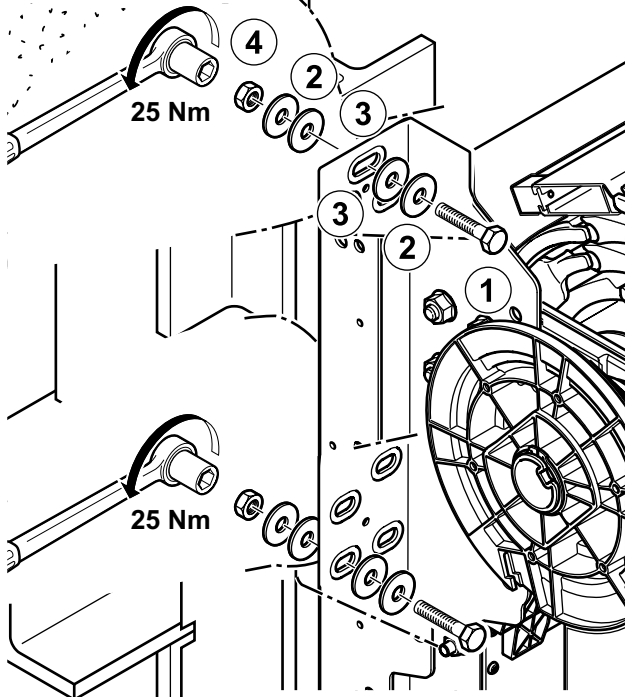
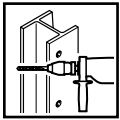

1	DIN 933 M8x40 A4
2	DIN 9021-8,4 A4
3	DIN 9021-8,4 KS
4	DIN 934-8-A4

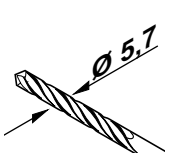
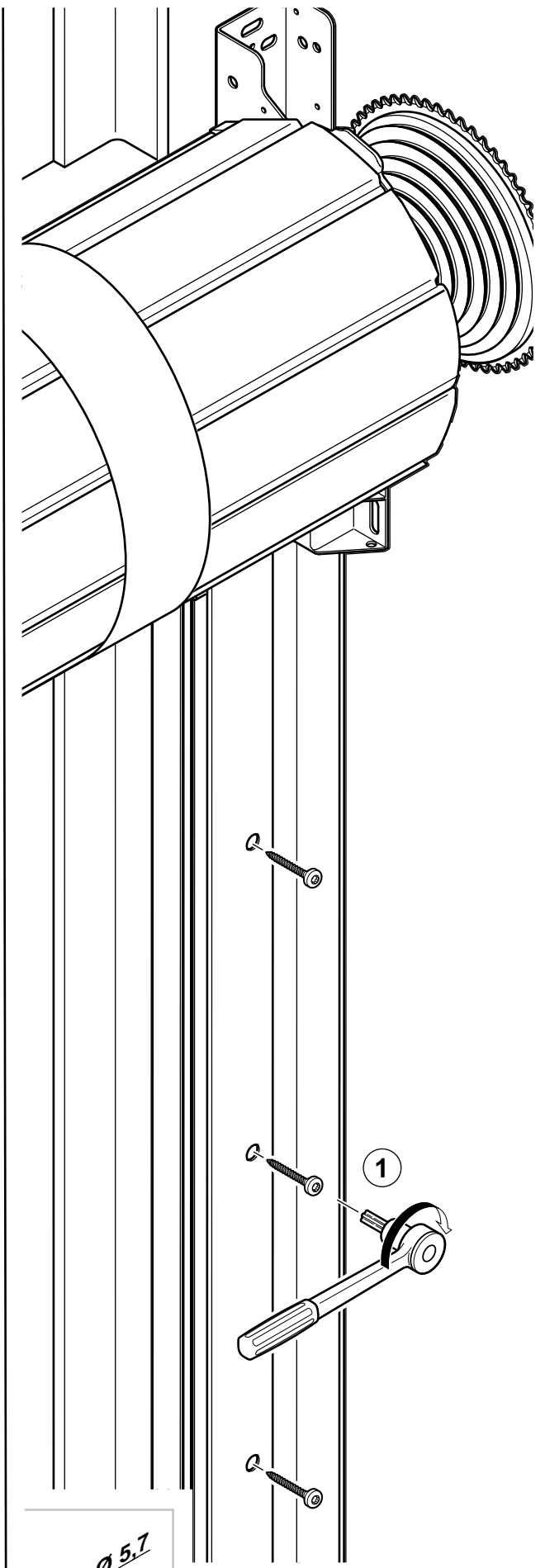
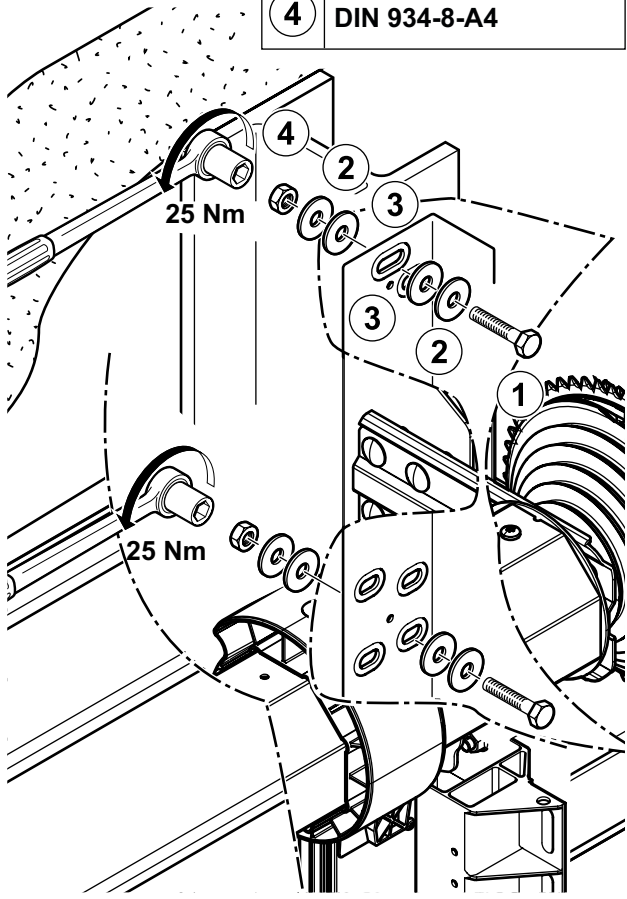
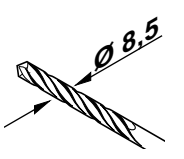

1	DIN 7981 C-T30 6,3x80
---	-----------------------

3.3b

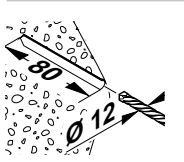
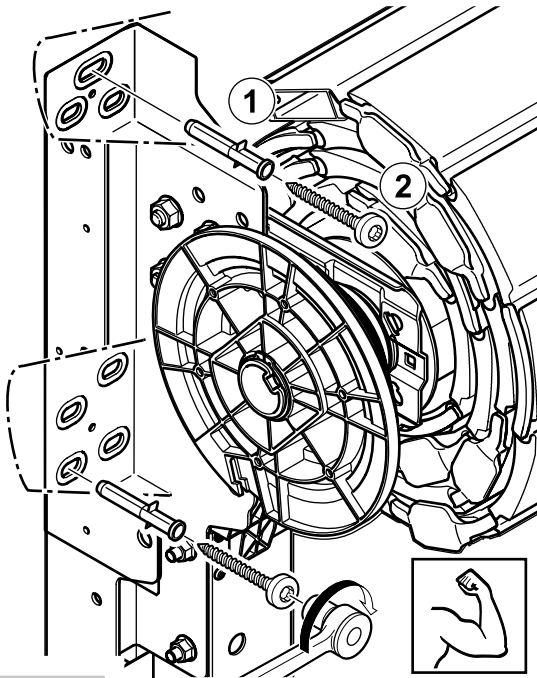
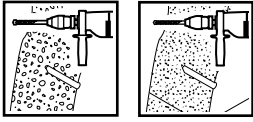

- | | |
|---|--------------------|
| 1 | Würth Shark Pro 12 |
| 2 | LK 10x80 T40 |

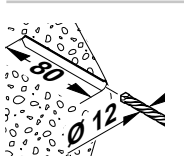
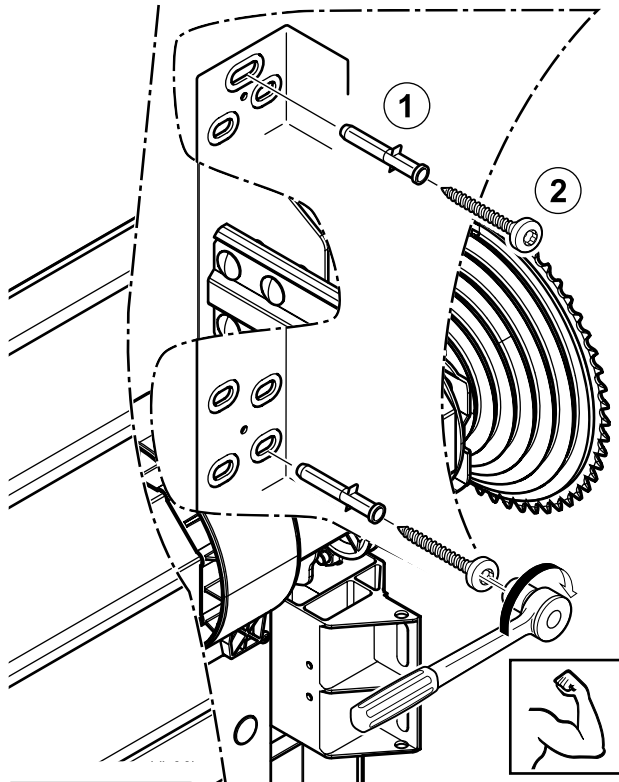

- | | |
|---|--------------------|
| 1 | Würth Shark Pro 12 |
| 2 | LK 10x80 T40 |

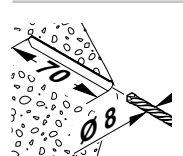
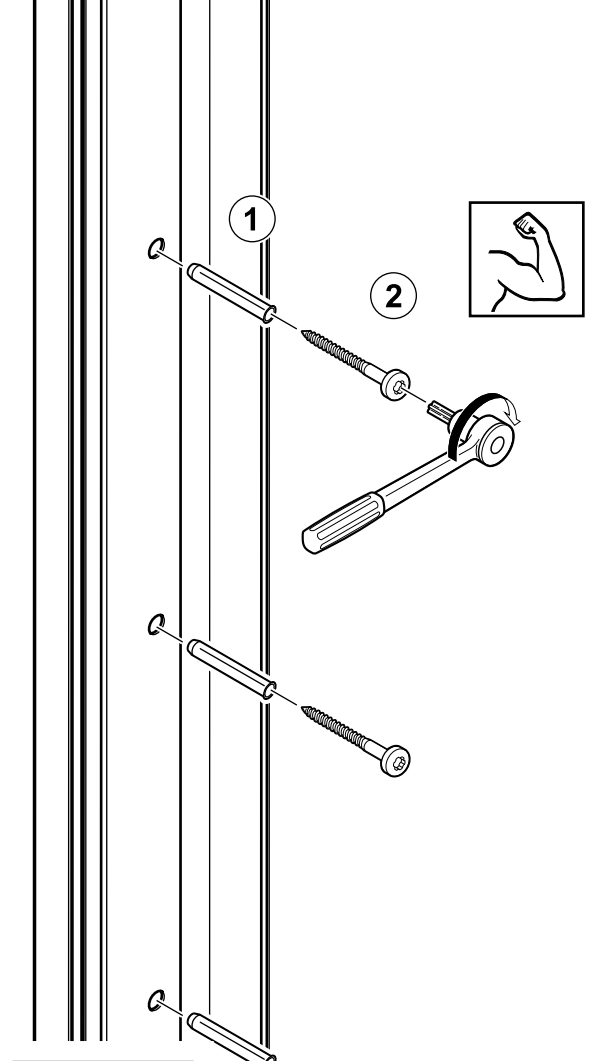
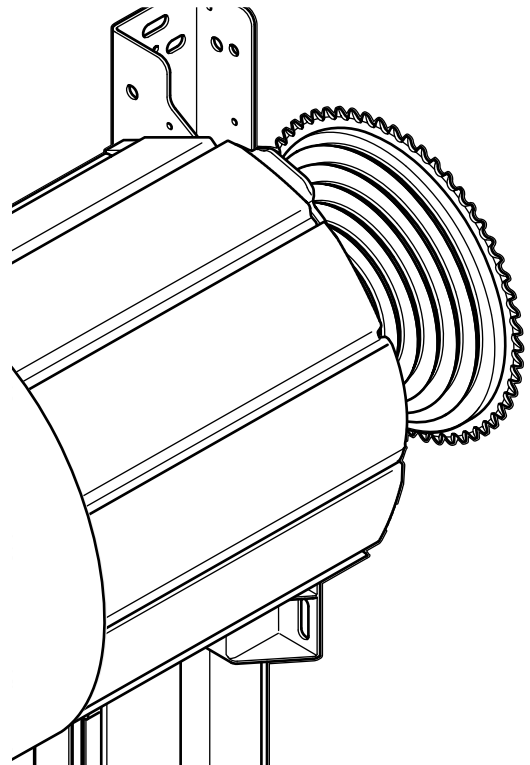

- | | |
|---|---------------------|
| 1 | Würth W-RD 8x30/100 |
| 2 | LK 6x100 T30 |

3.3c

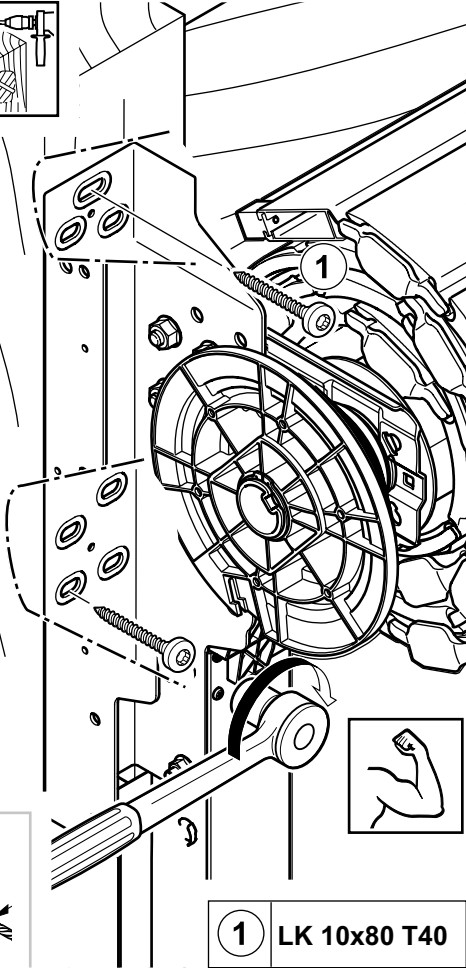

1 LK 10x80 T40

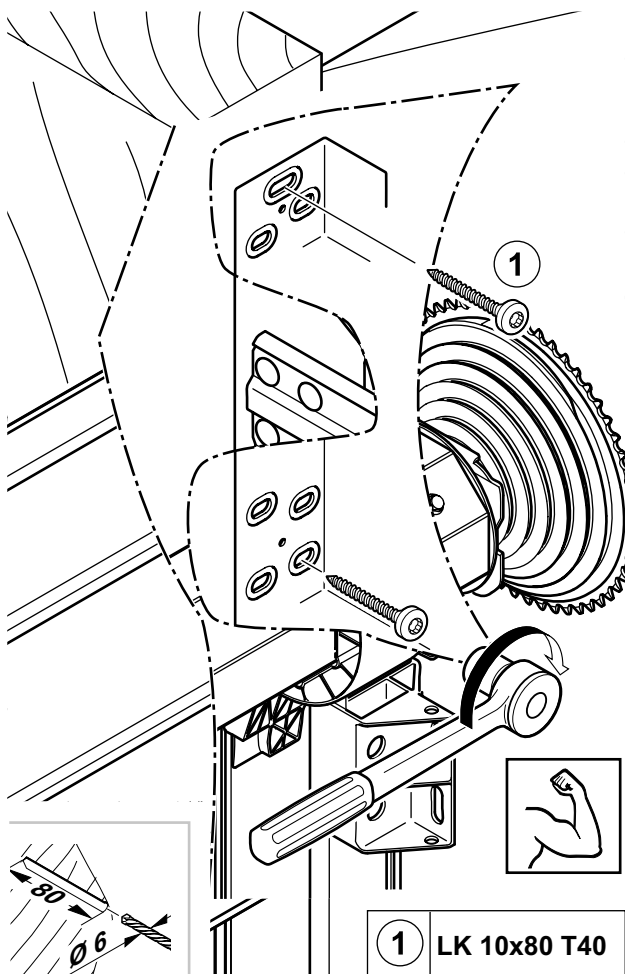

1 LK 10x80 T40

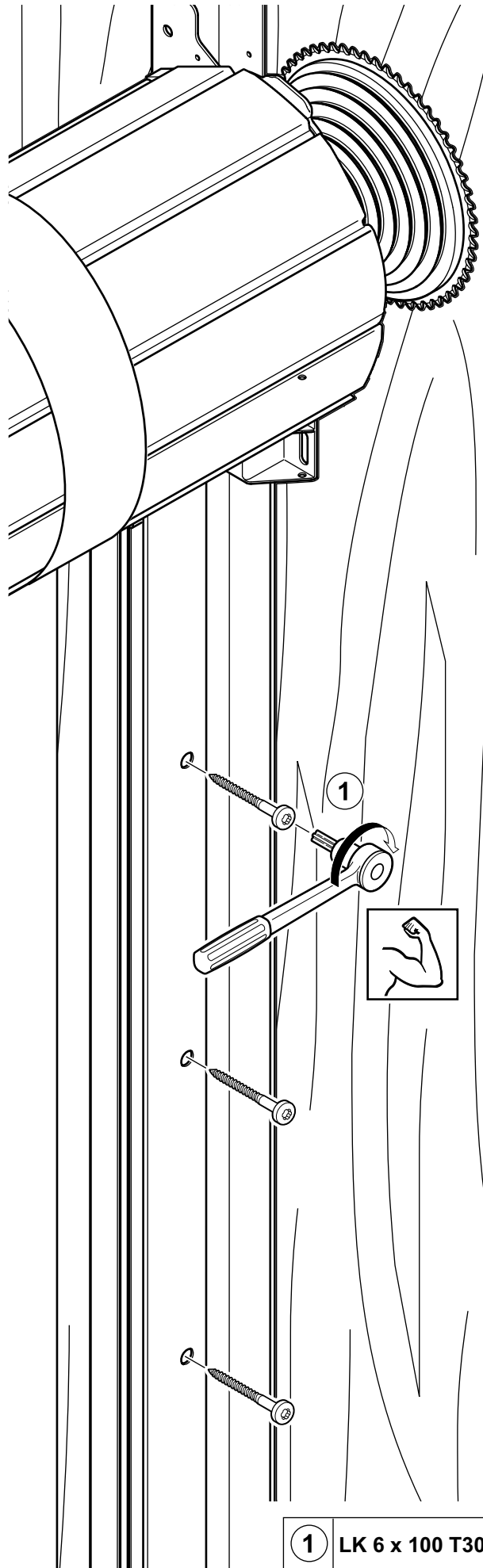

1 LK 6 x 100 T30

4

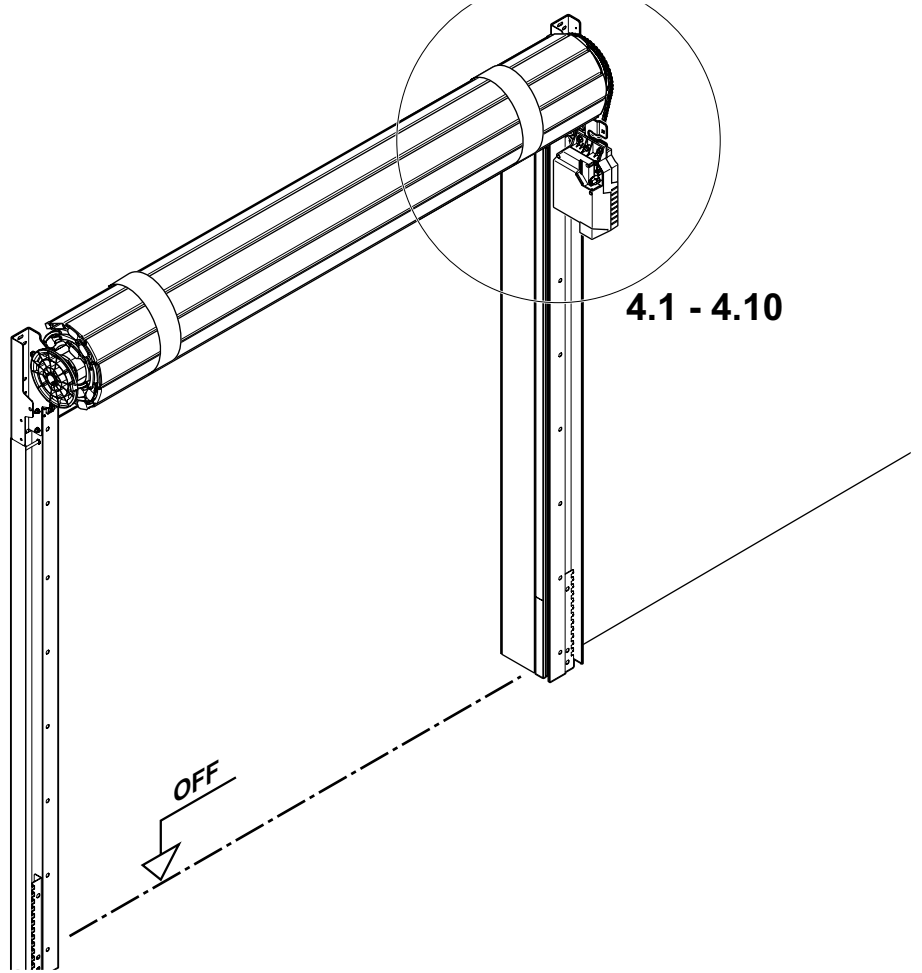
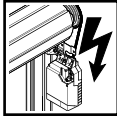

4.1

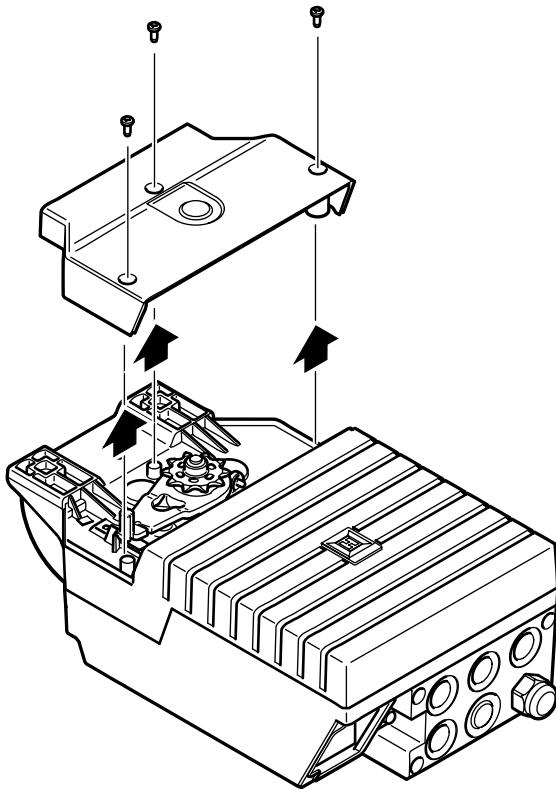

4.2

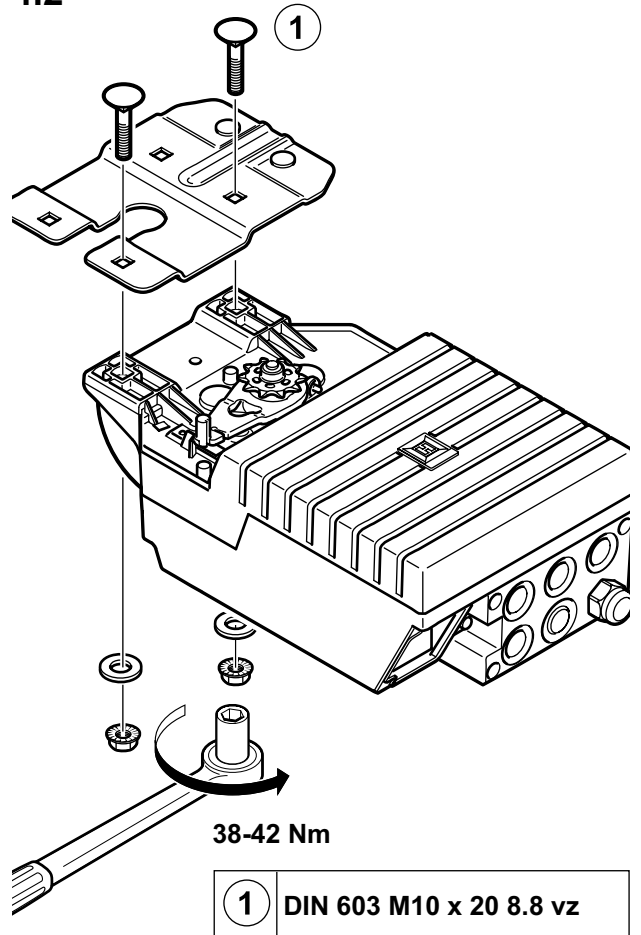

4.3

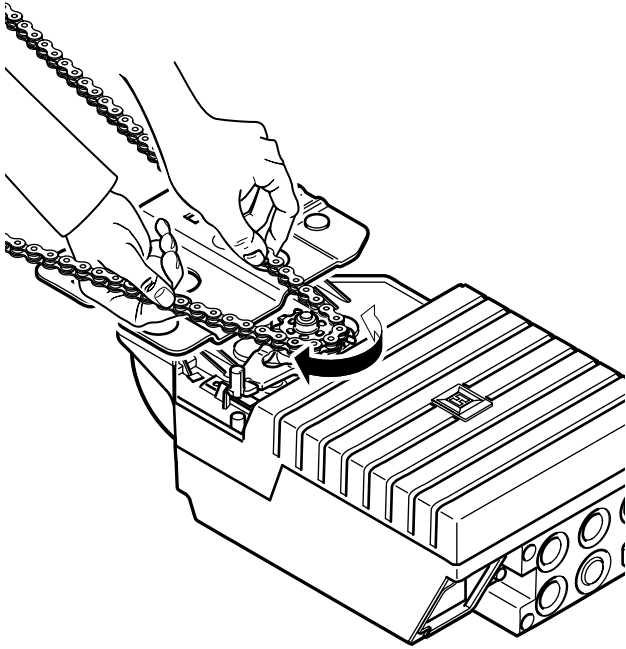

4.4

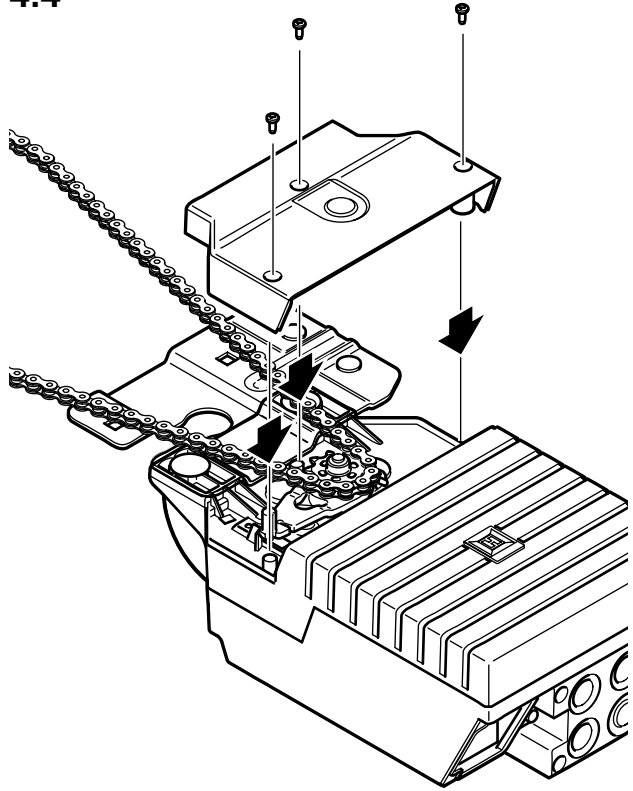

4.5

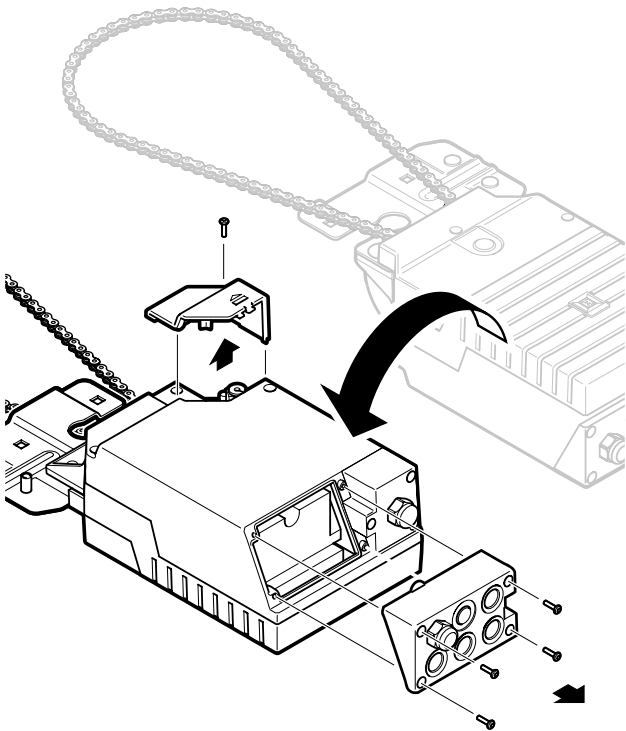

4.6a

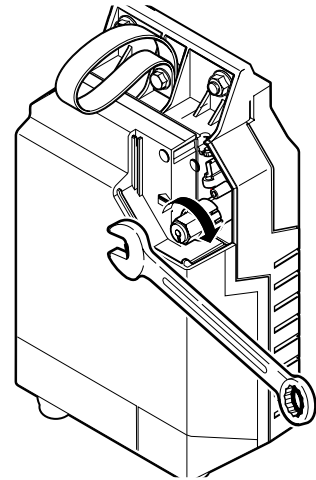
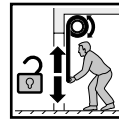

4.6b

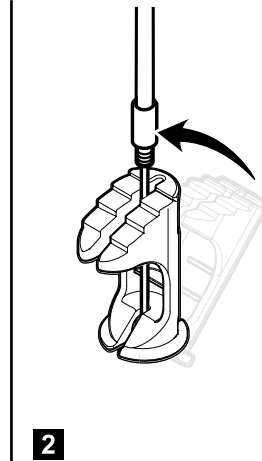
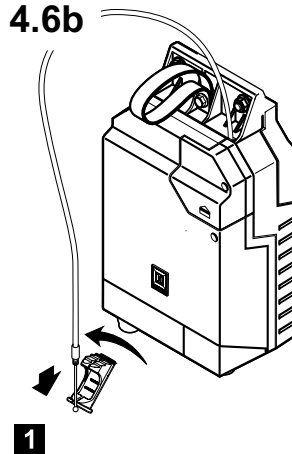

4.7

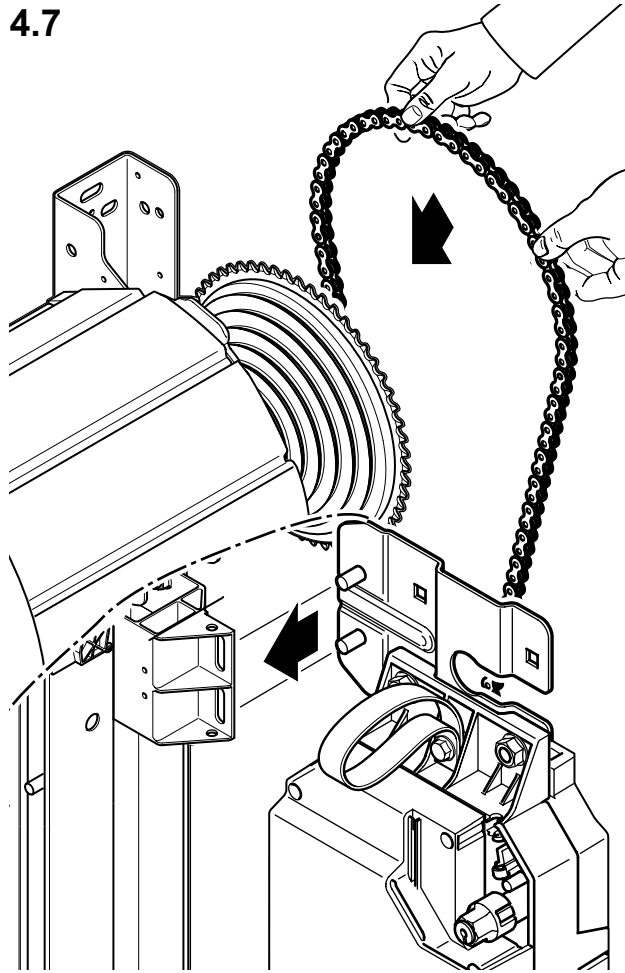

4.8

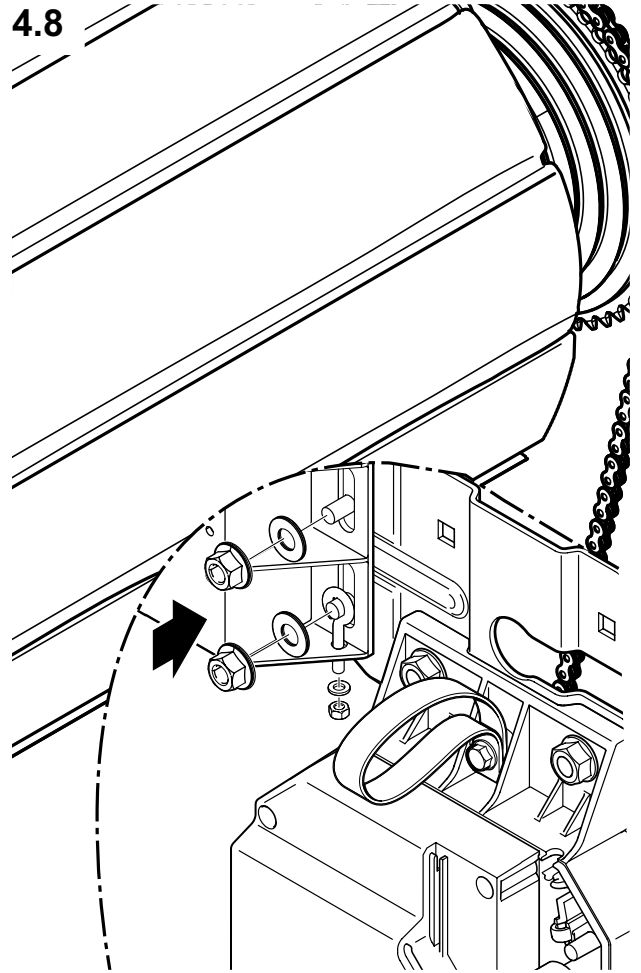

4.9

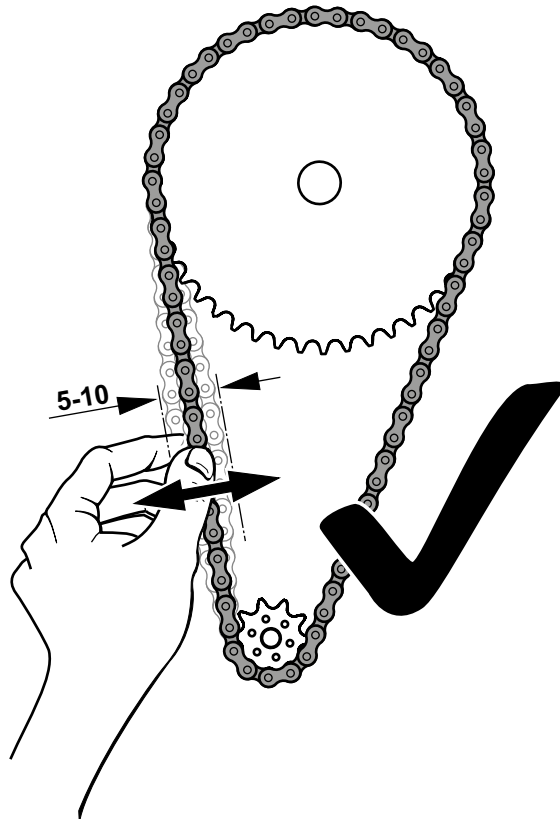

4.10

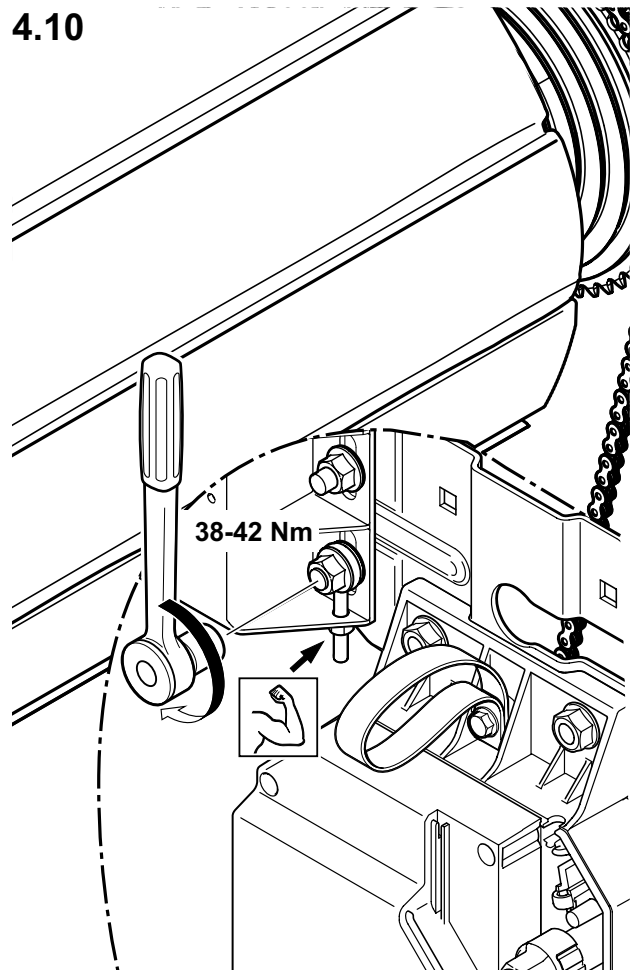

5

5.1 - 5.2

5.3

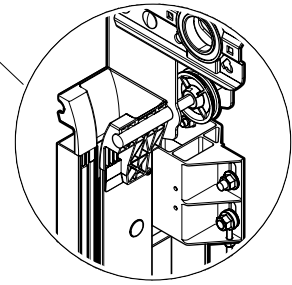
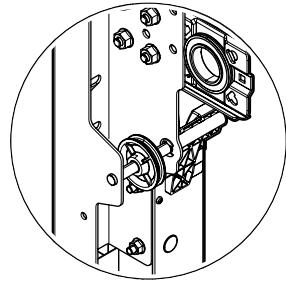

5.1

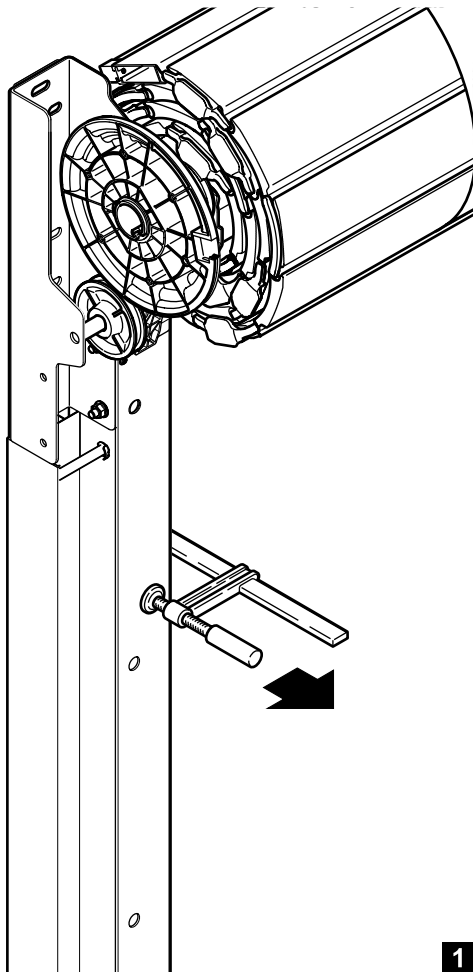

1

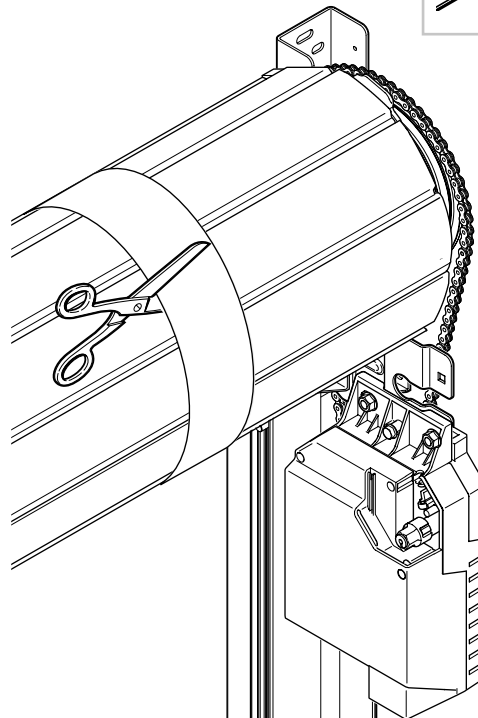
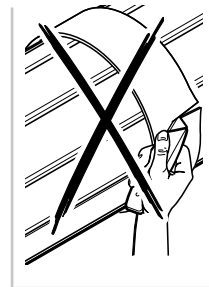

2

5.2

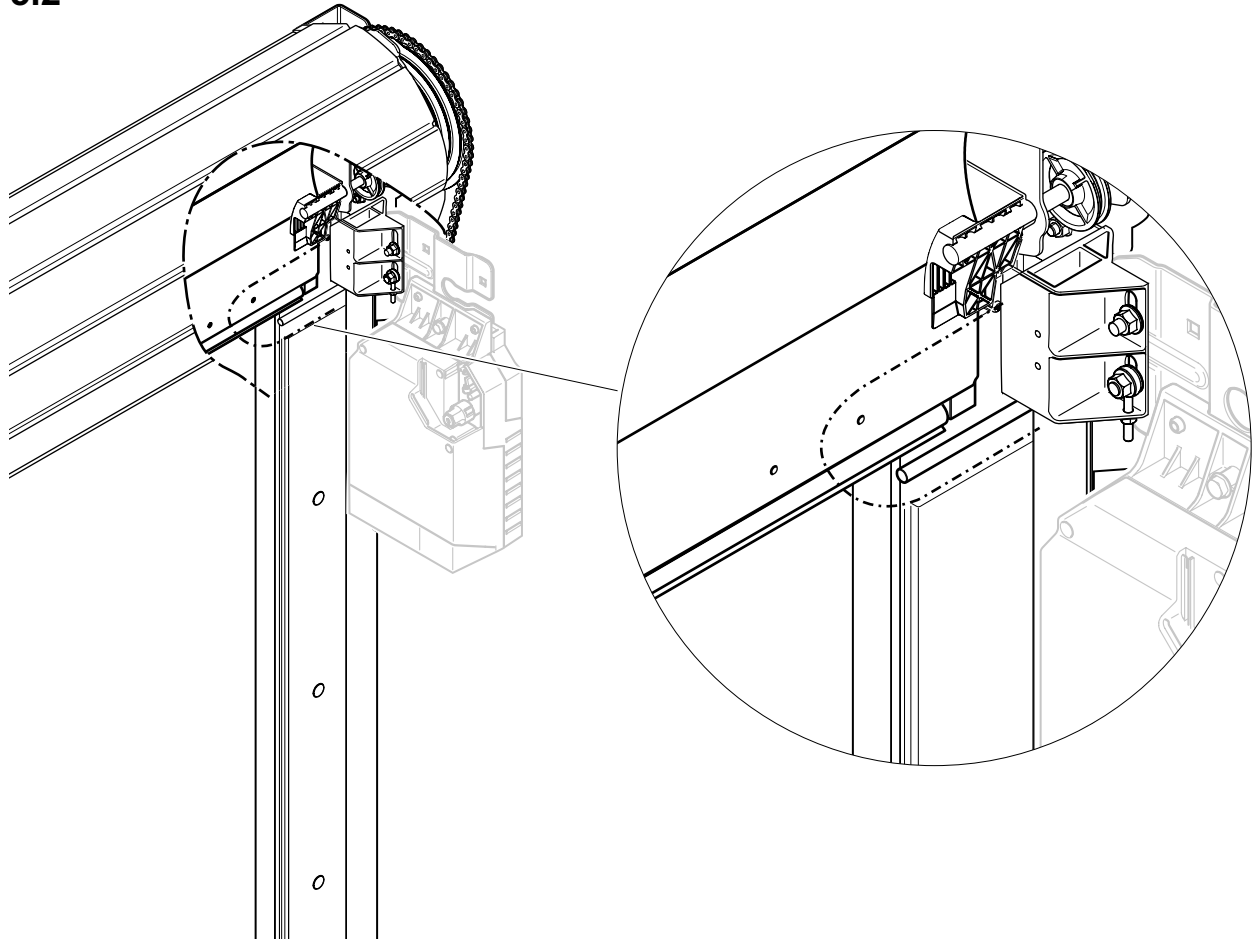

5.3

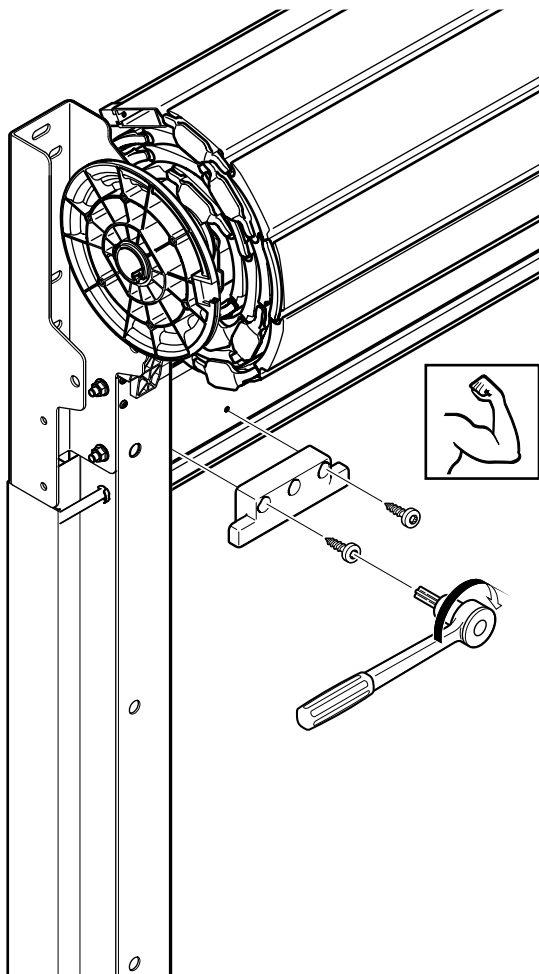

5.4

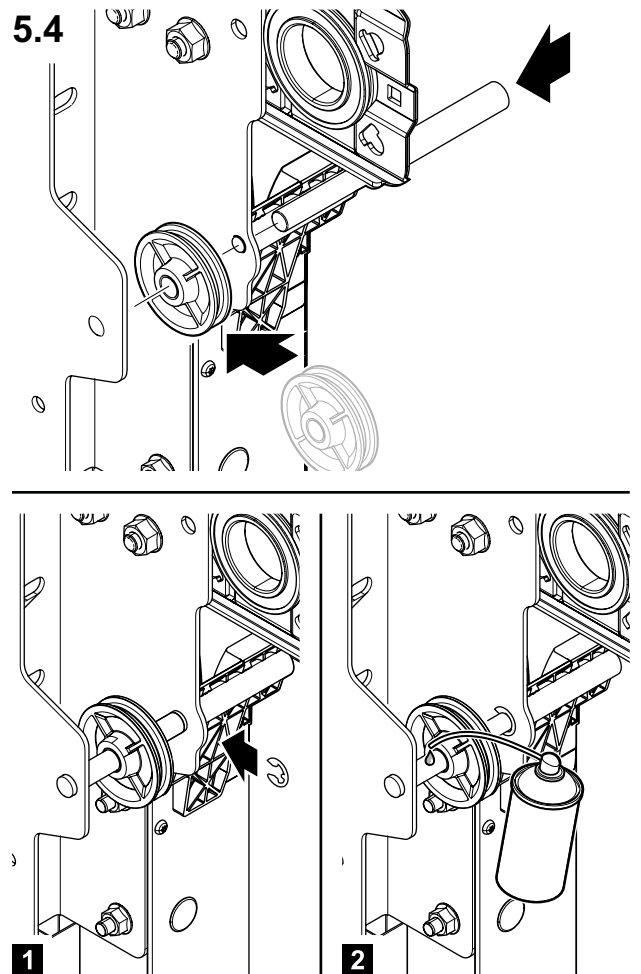

6

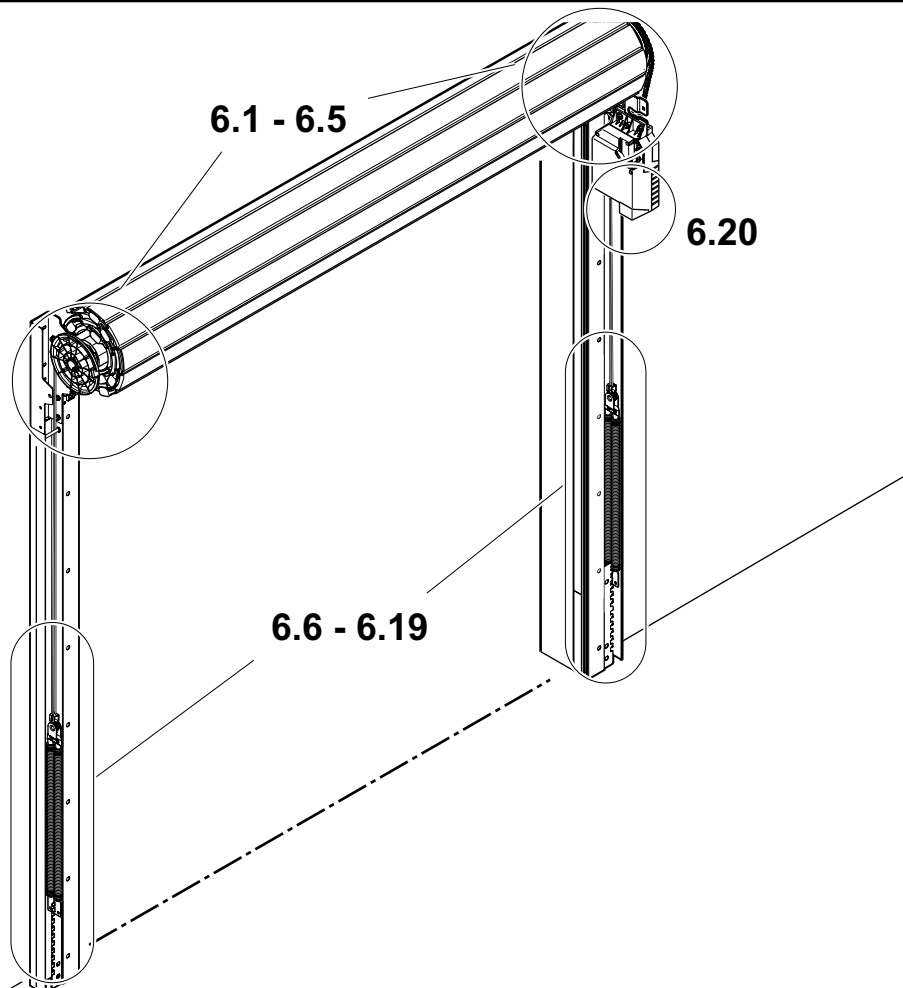

6.1

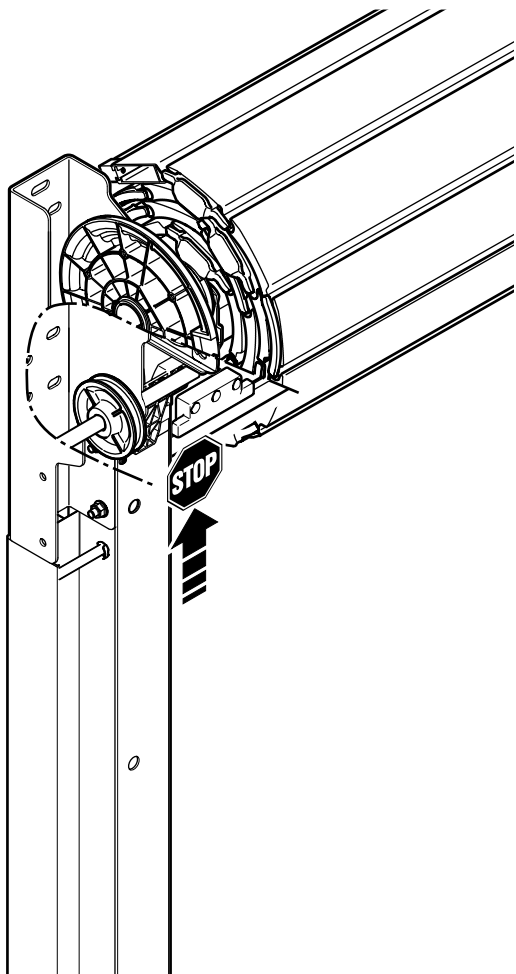

6.2

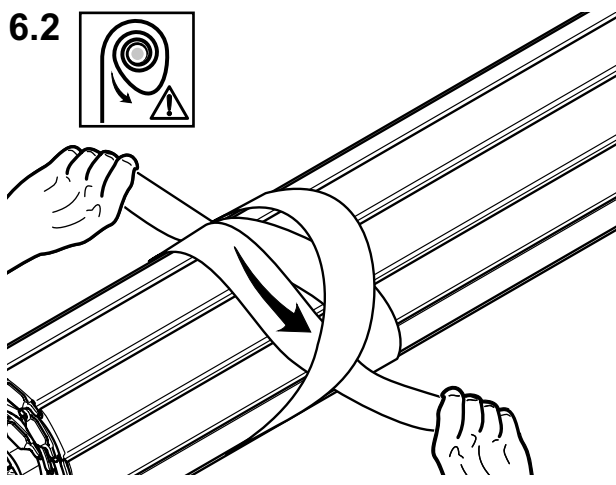

6.3

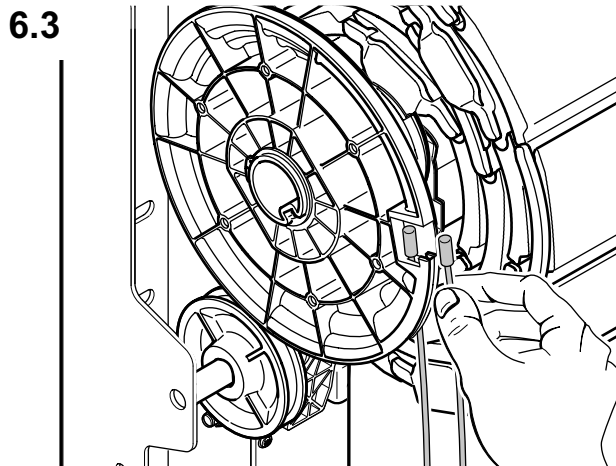

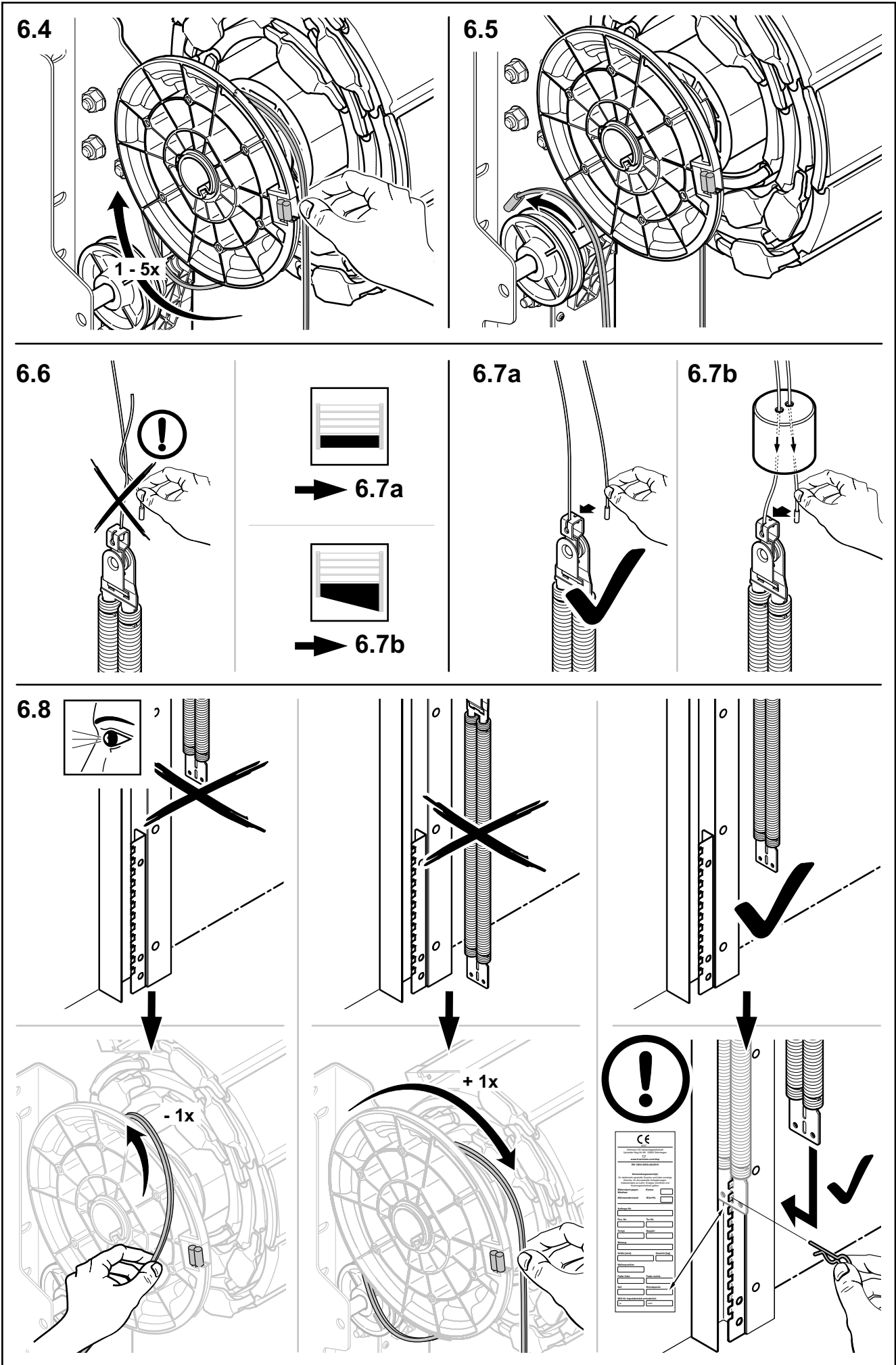

6.9a

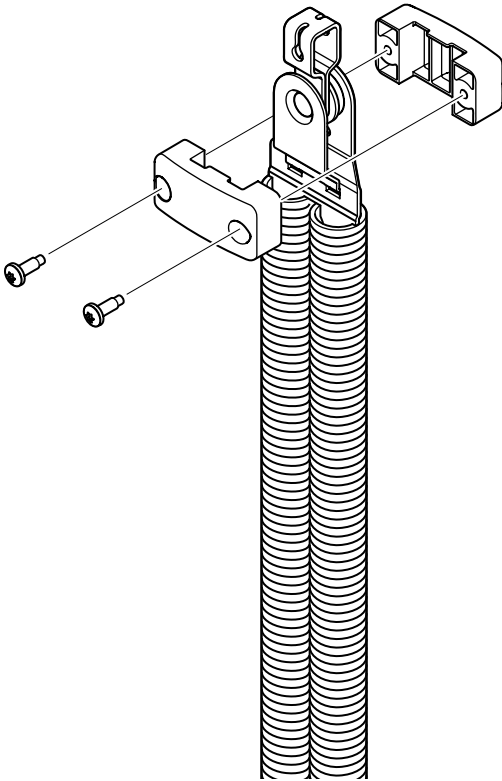

2

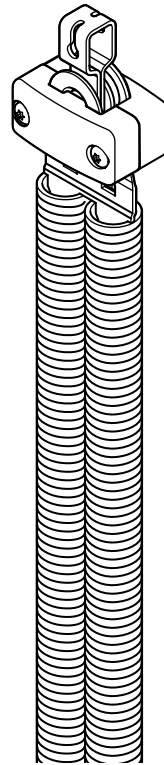

6.9b

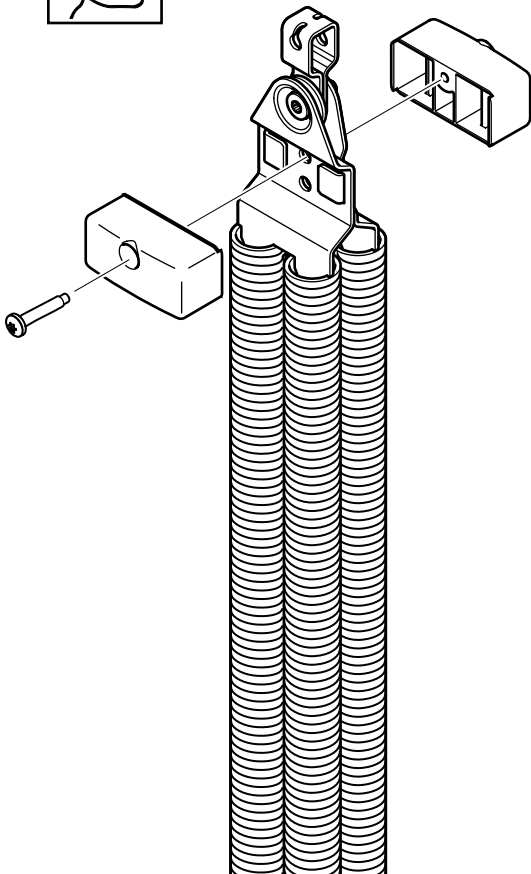

2

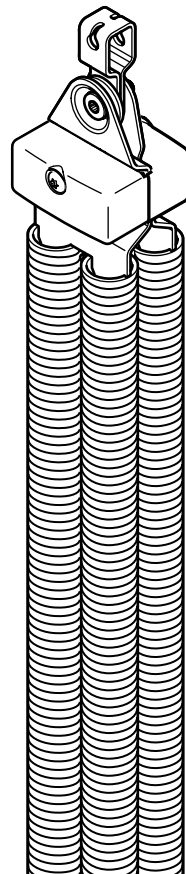

6.10

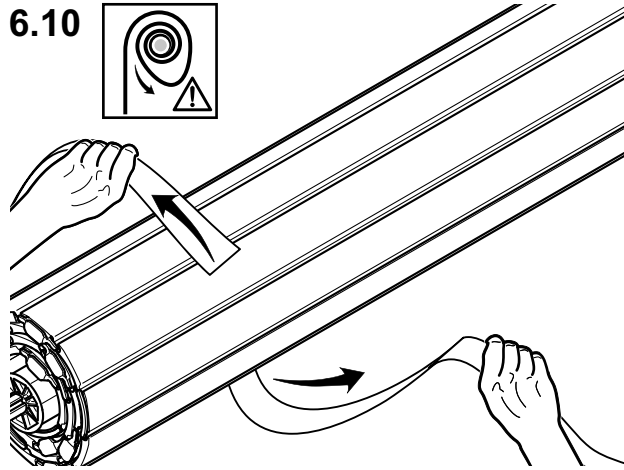

6.11

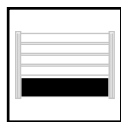
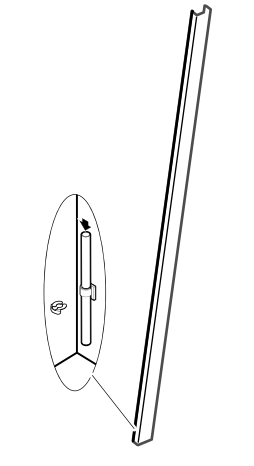
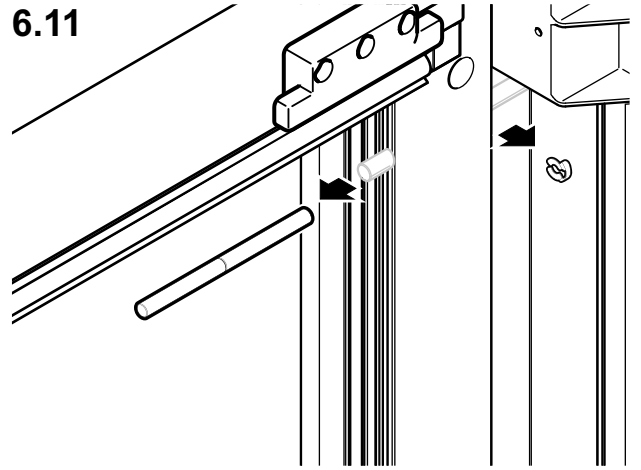

➔ 6.16



➔ 6.12

6.12

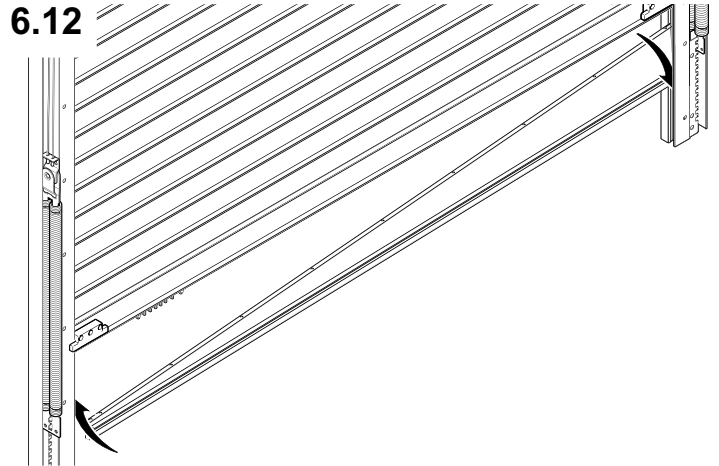

6.13

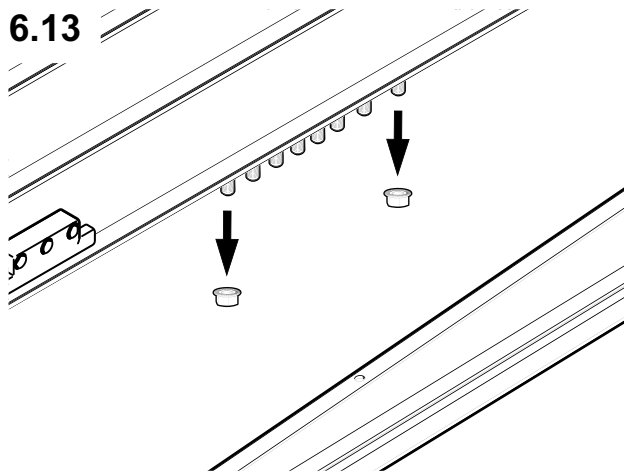

6.14

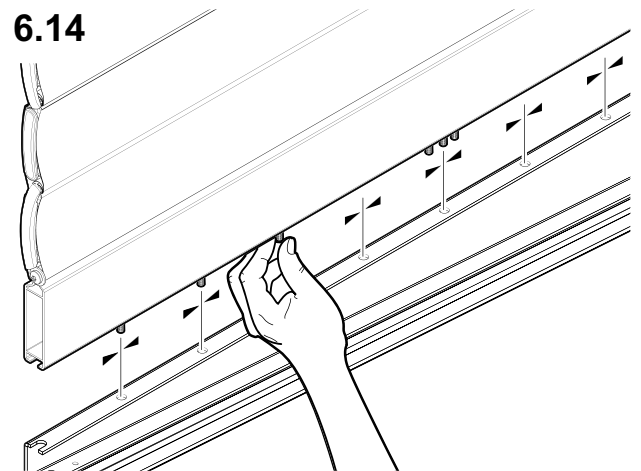

6.15

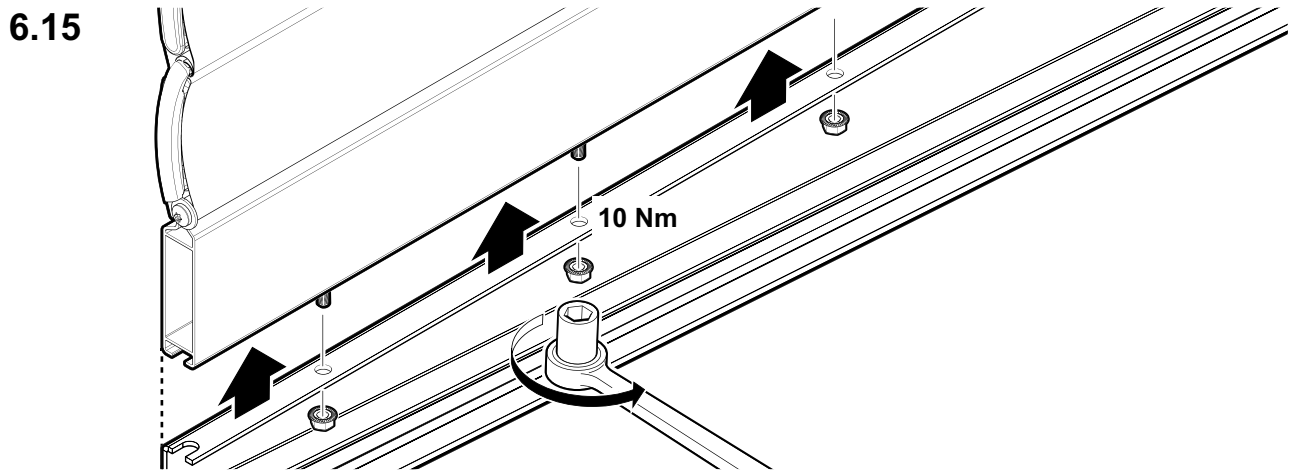

6.16

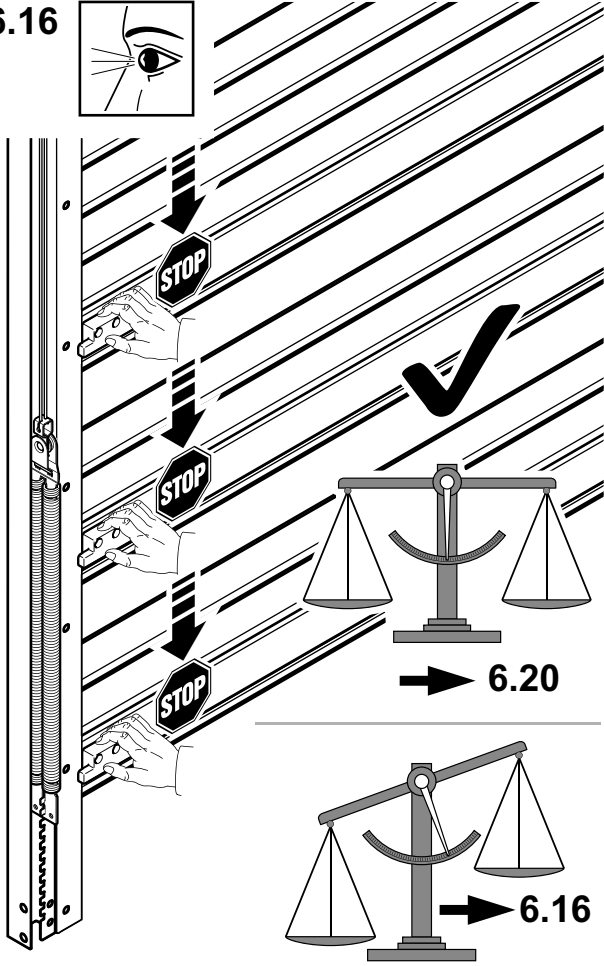

6.17

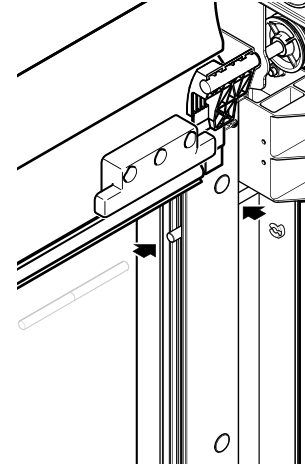
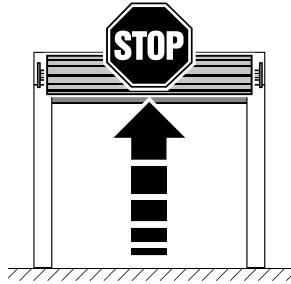

6.18

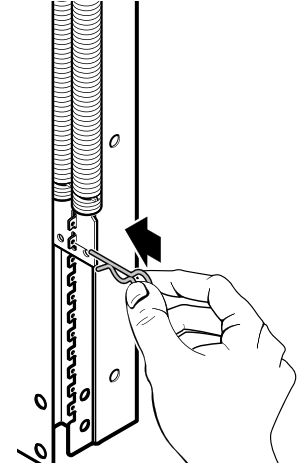
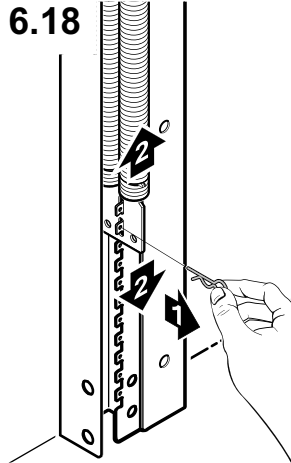

6.19

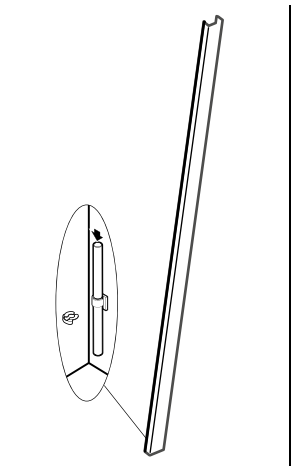
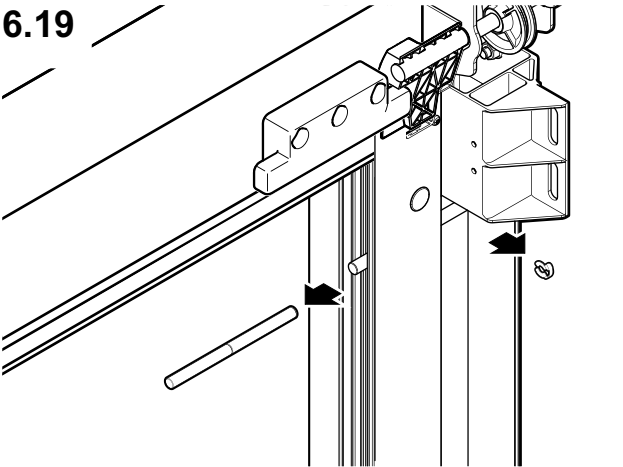

6.20

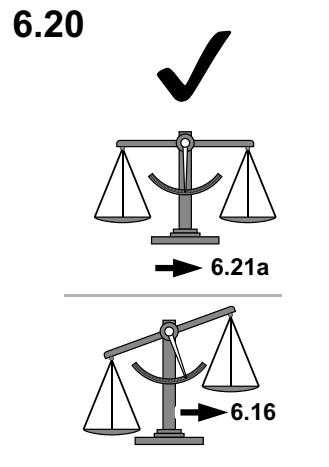

6.21a

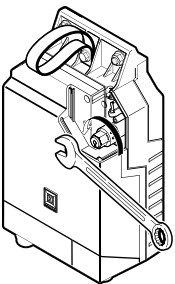

6.21b

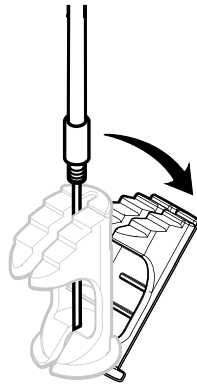
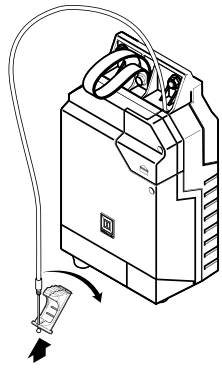

6.22

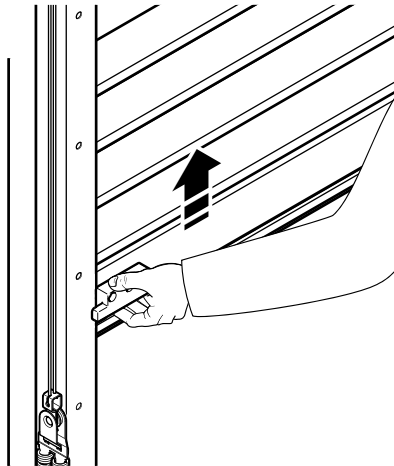

7

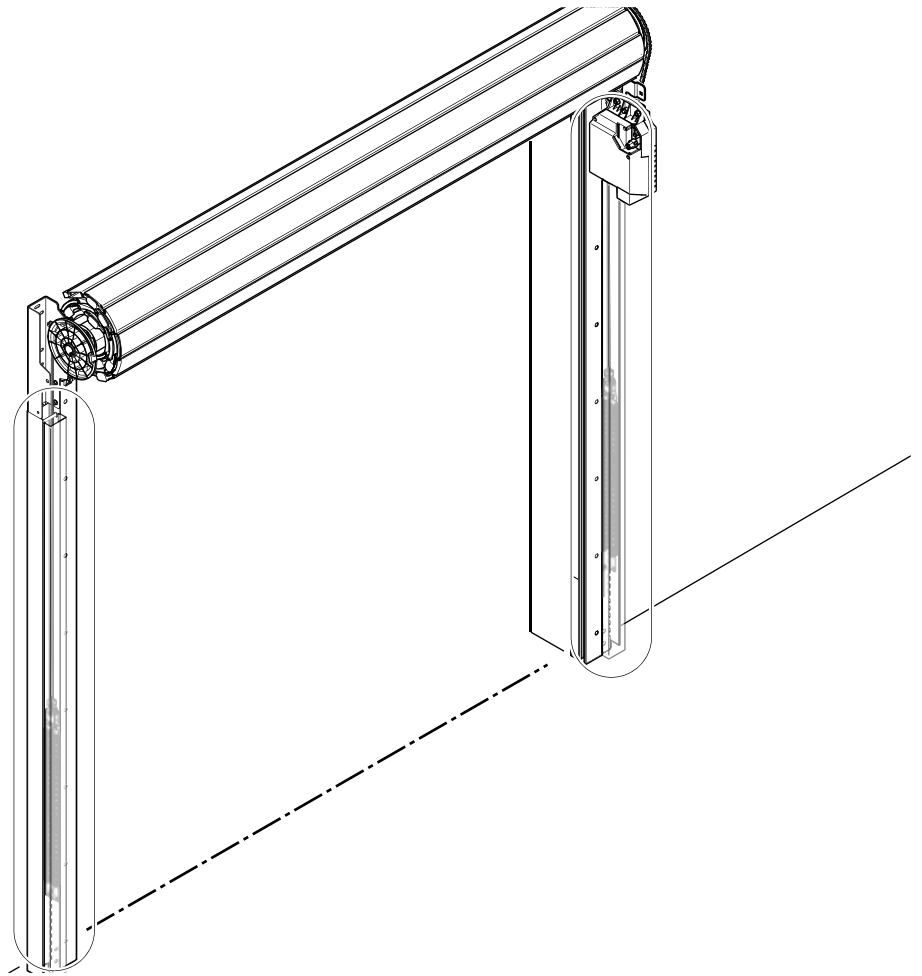

7.1

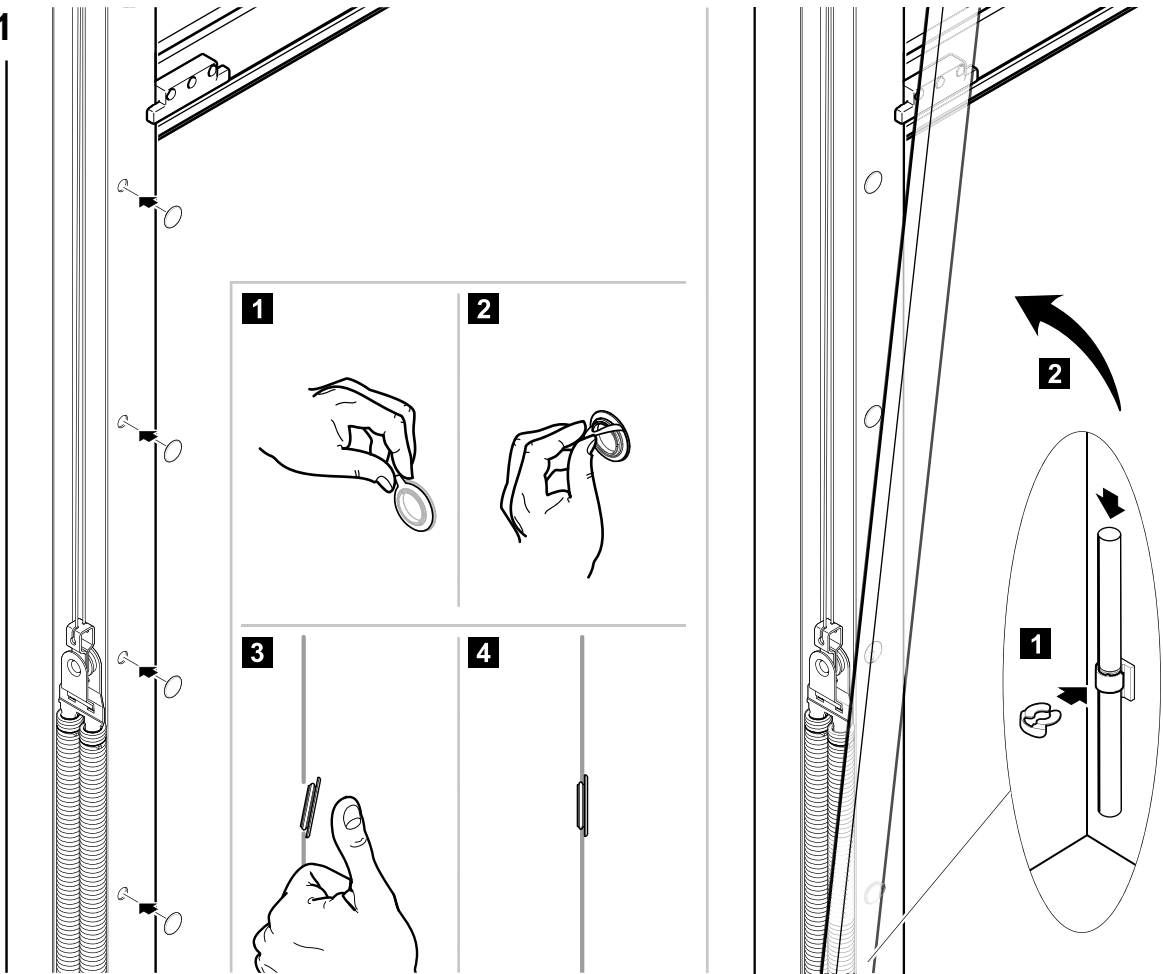

8

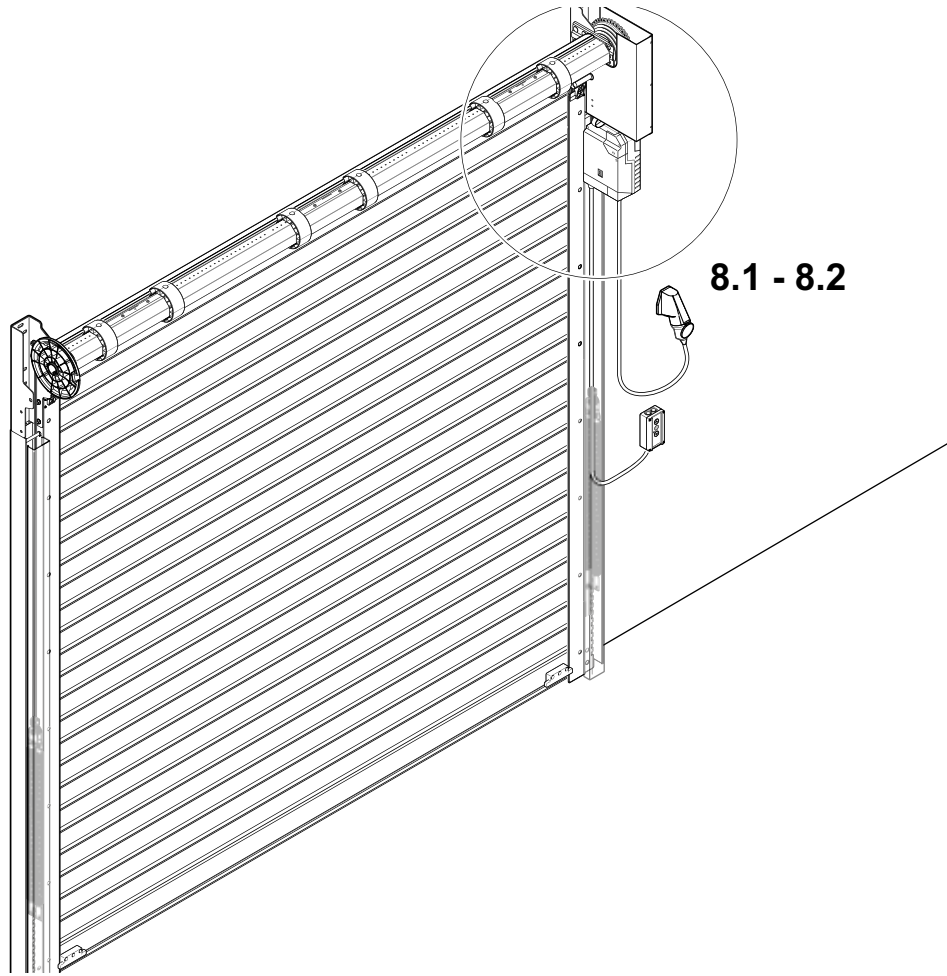

8.1 - 8.2

8.1

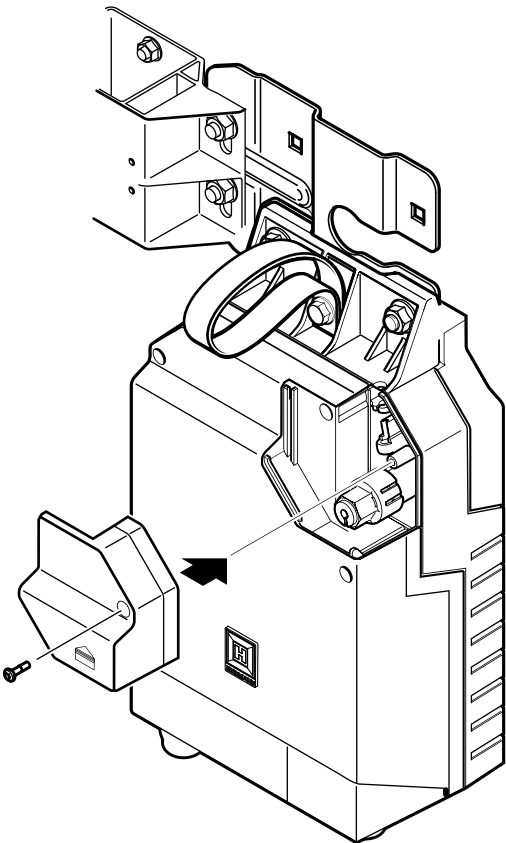

8.2

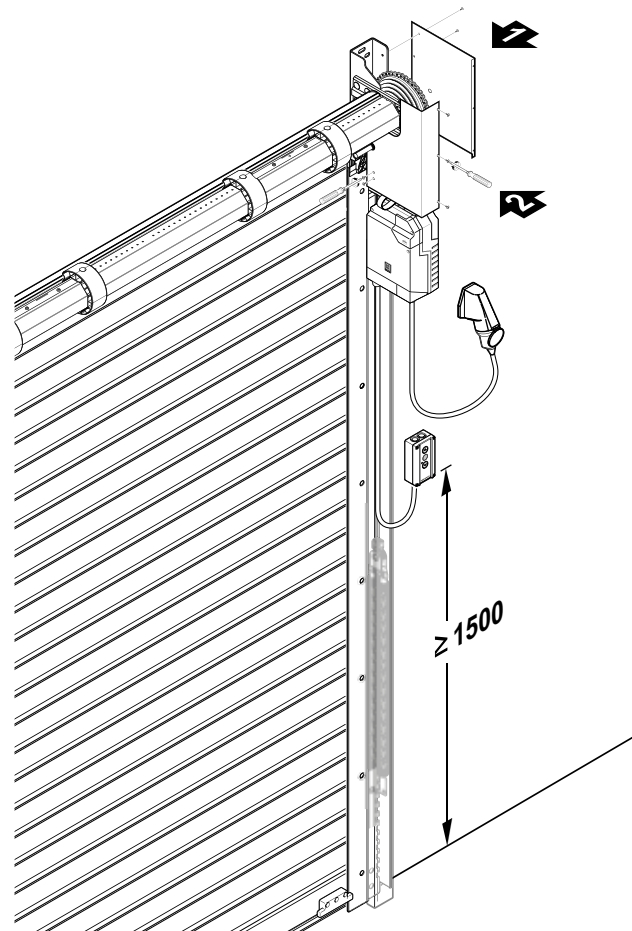

9

9.1 - 9.2

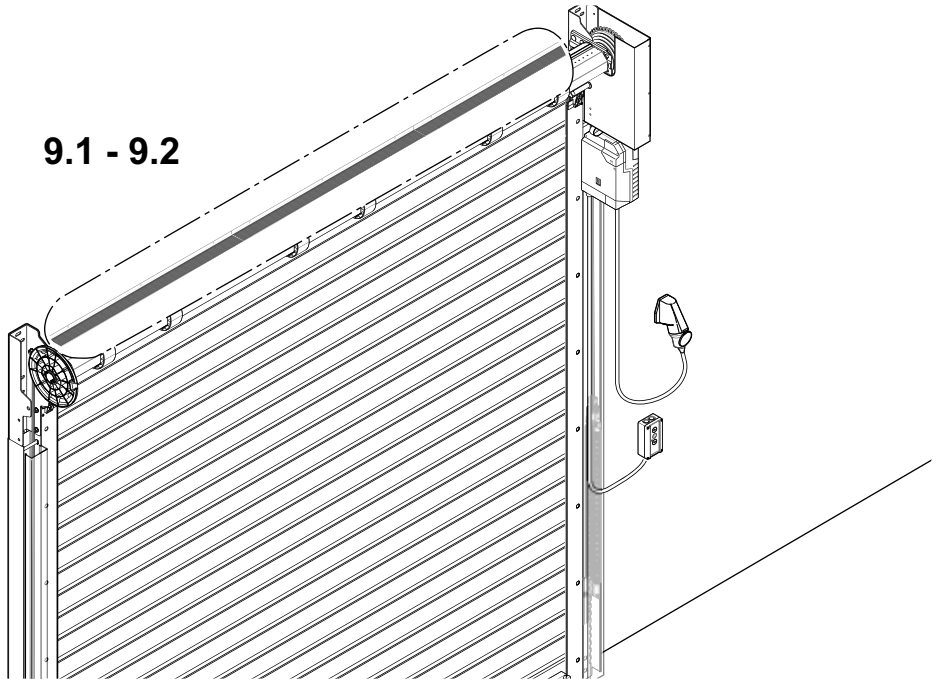

9.1

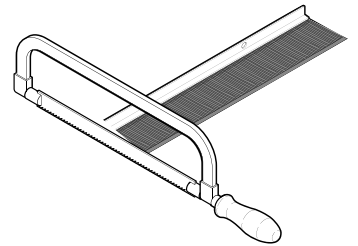
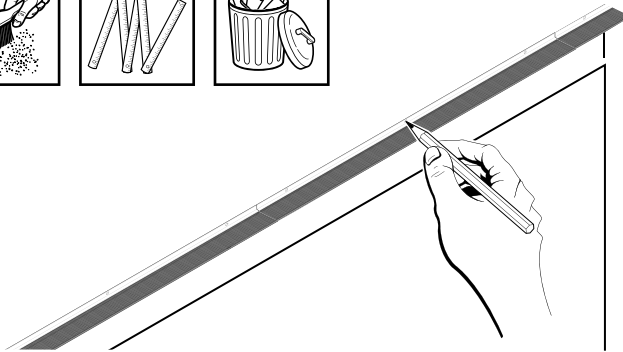

9.2

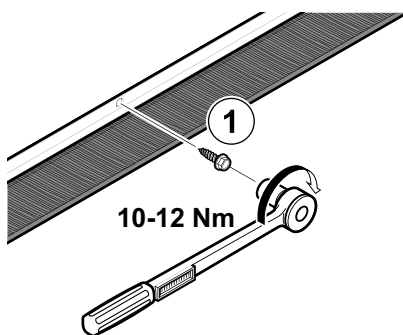
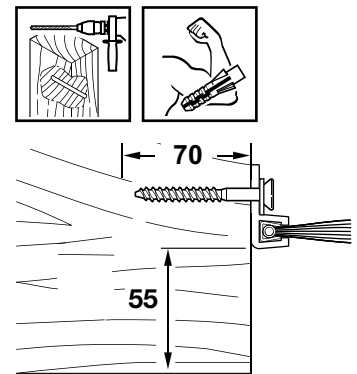
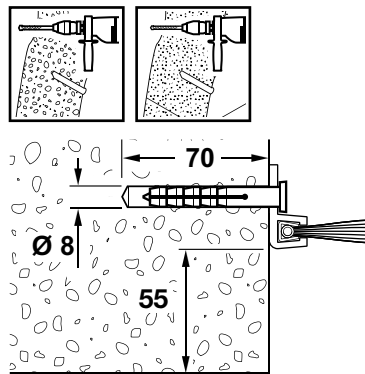
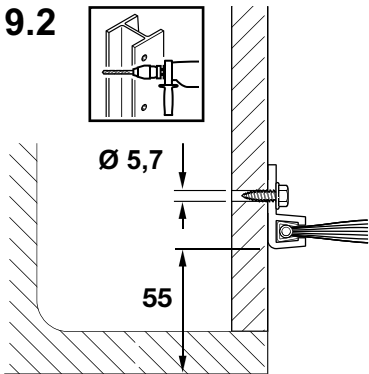

1 DIN7981C-T30 6,3x19

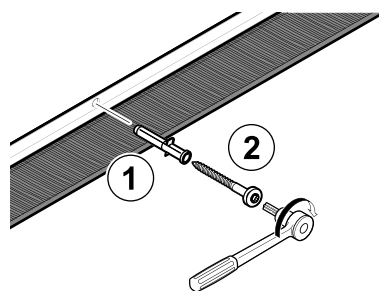

1	Würth Shark Pro 8
2	LK 6x60 T30

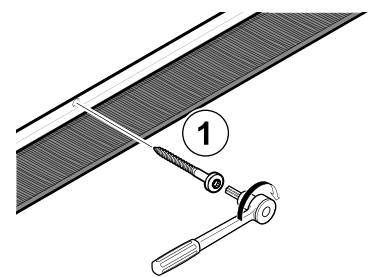

1 LK 6x60 T30

10

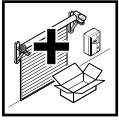

10.1 - 10.6

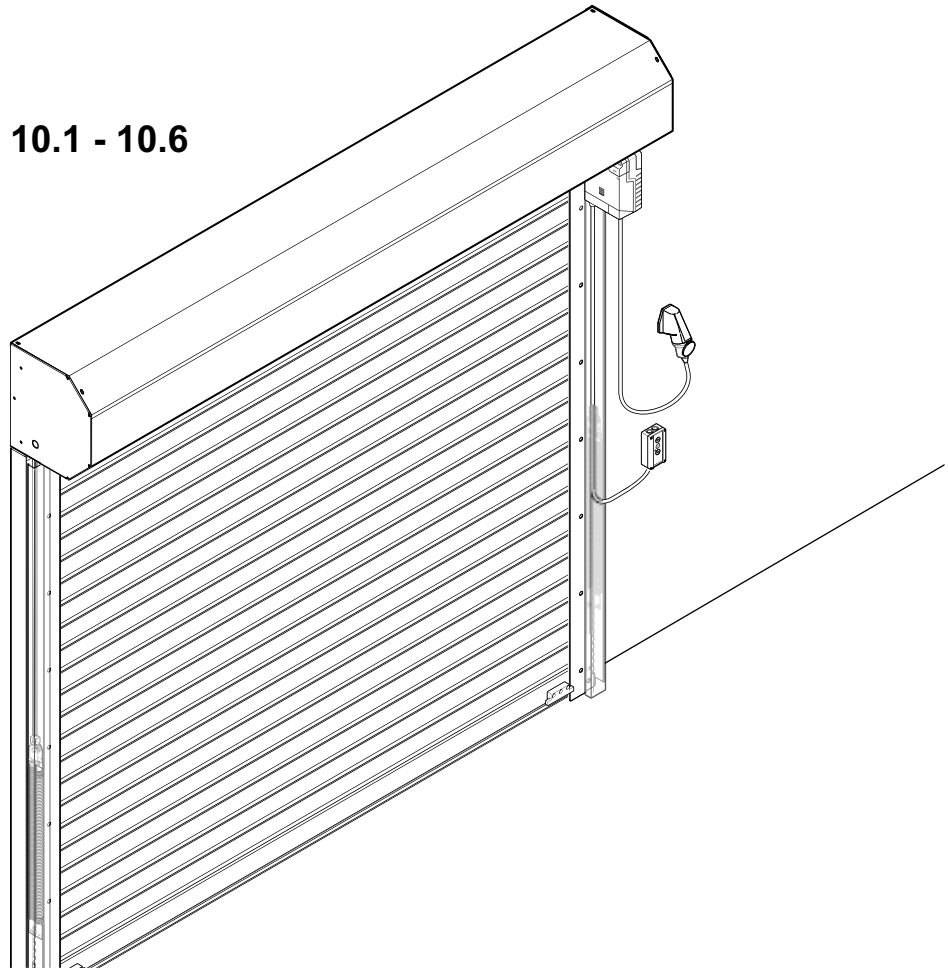

10.1

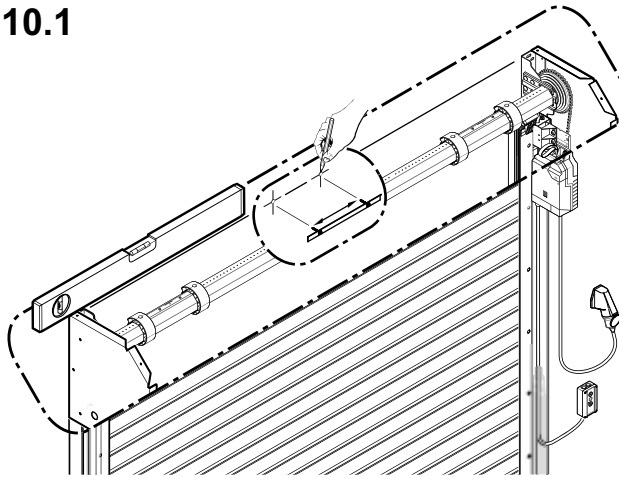

10.2

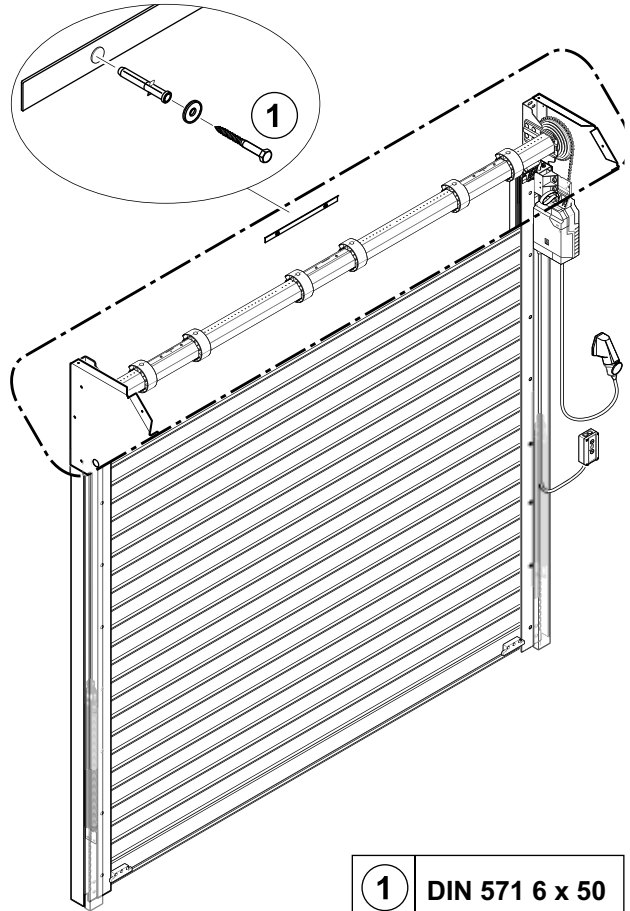

1 DIN 571 6 x 50

10.3

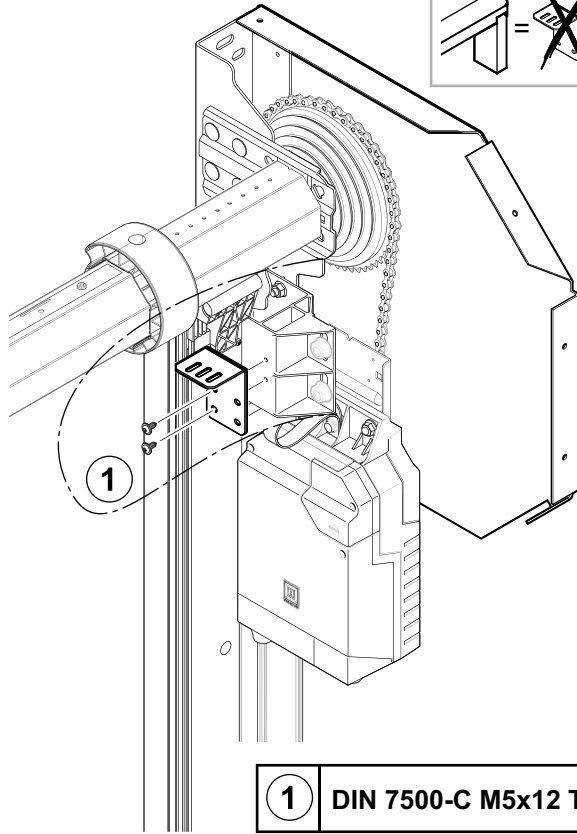

10.4

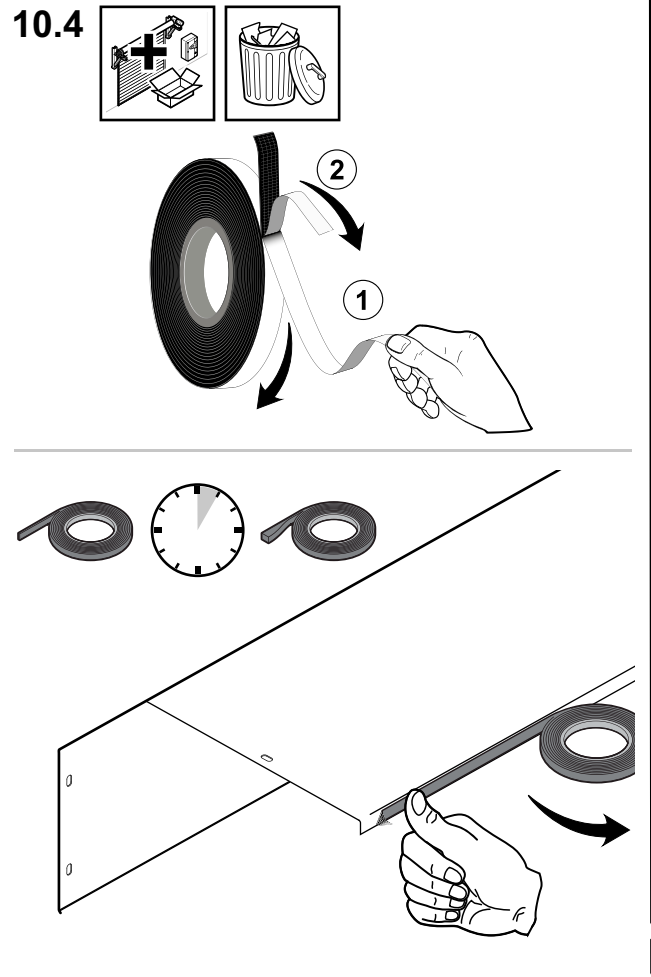

10.5

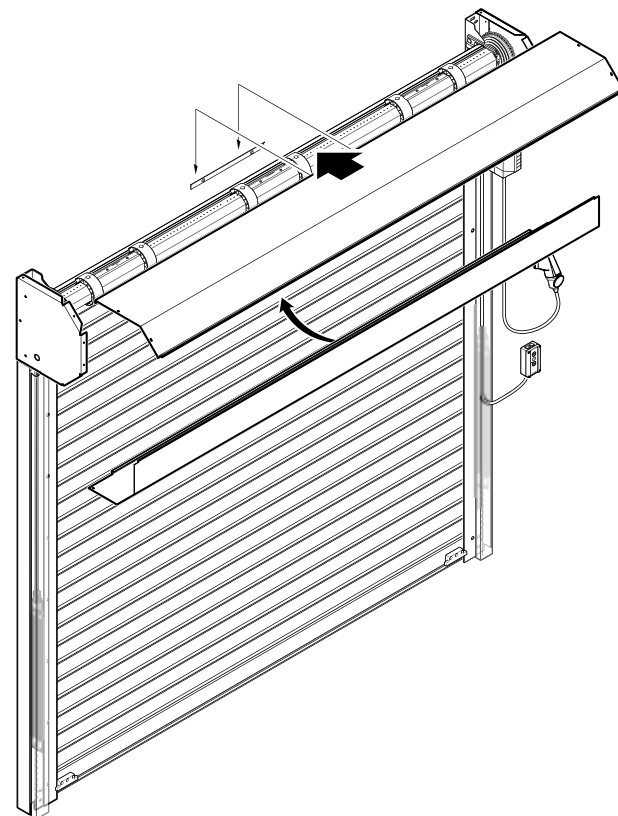

10.6

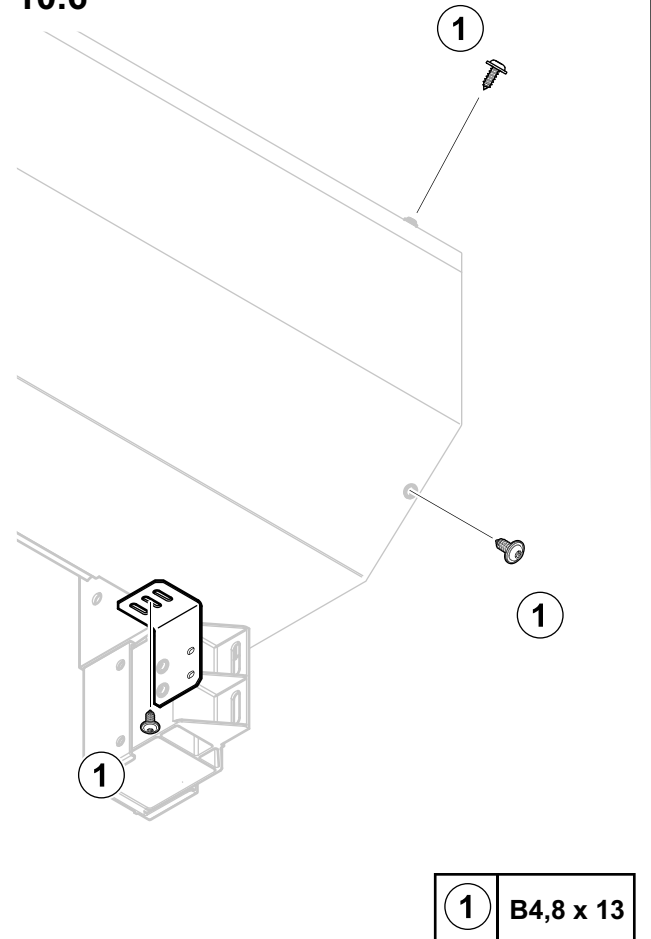

11

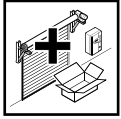

11.1 - 11.6

11.1

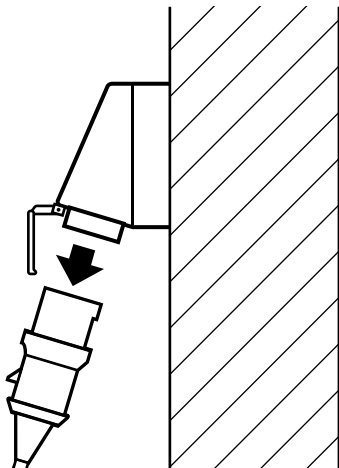
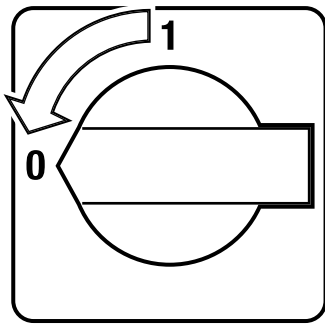

11.2

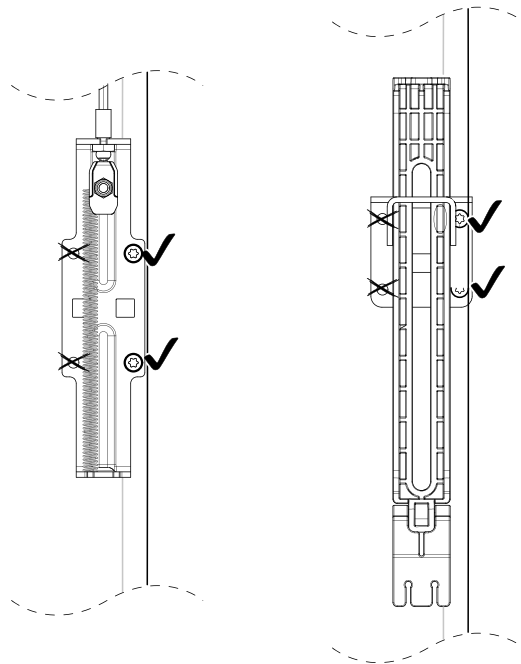
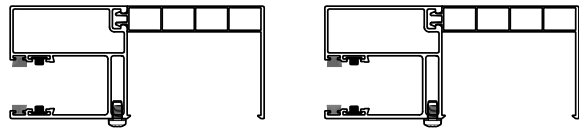

11.3

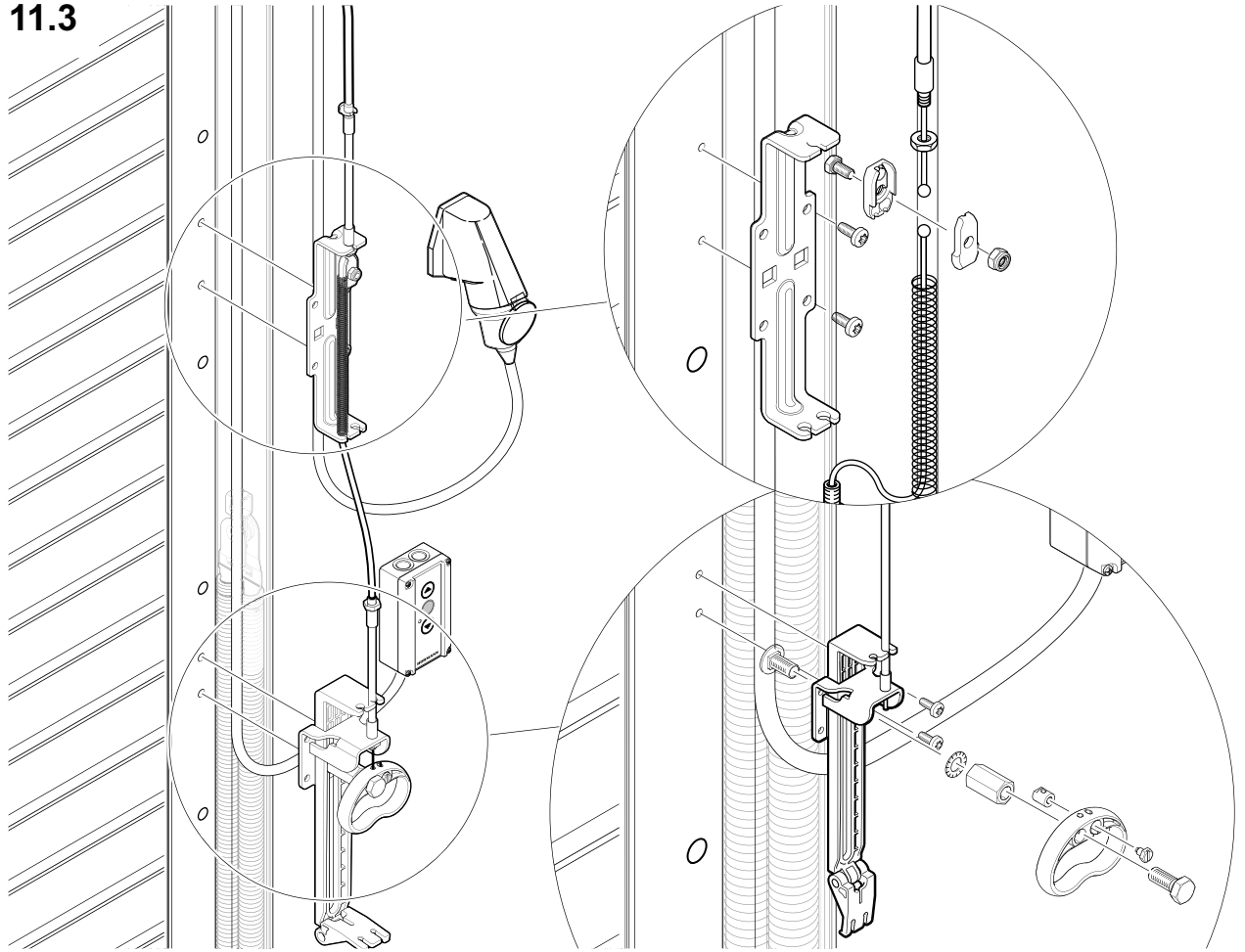

11.4

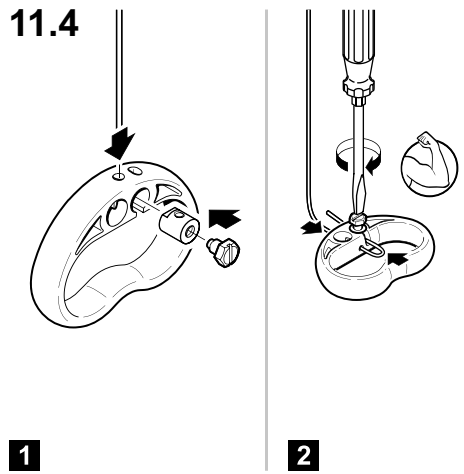

11.5

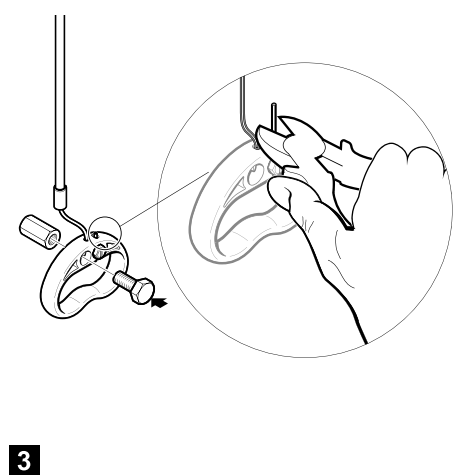
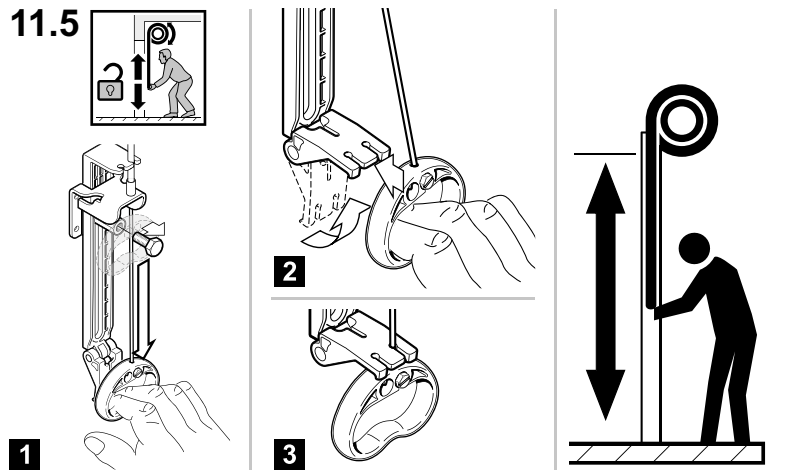

11.6

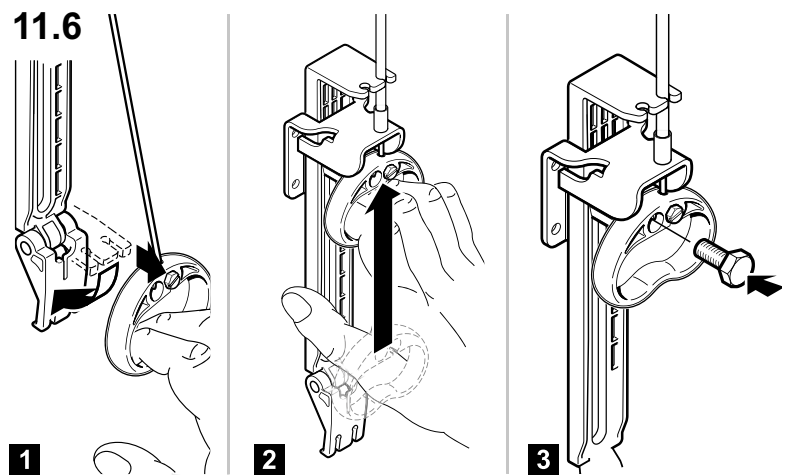

12

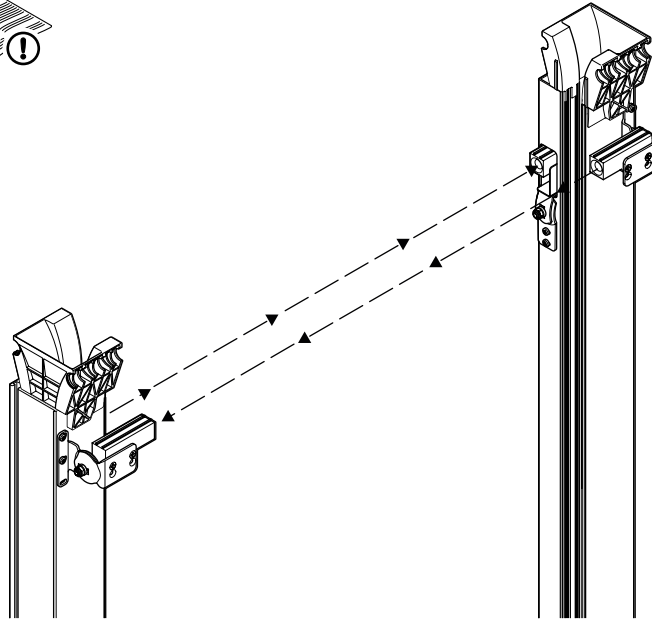

12.1

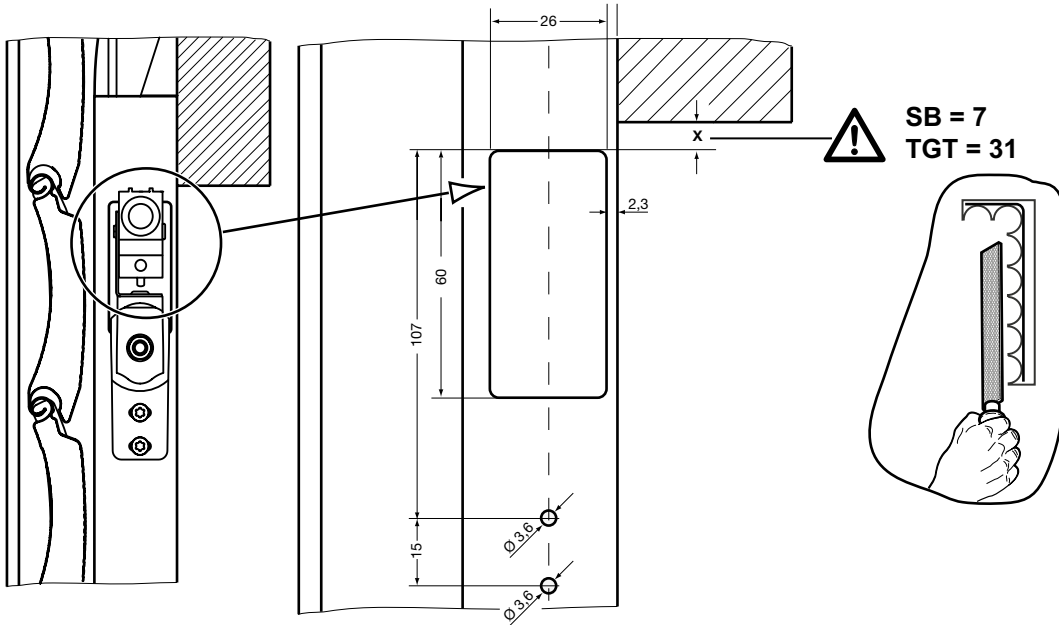

12.2

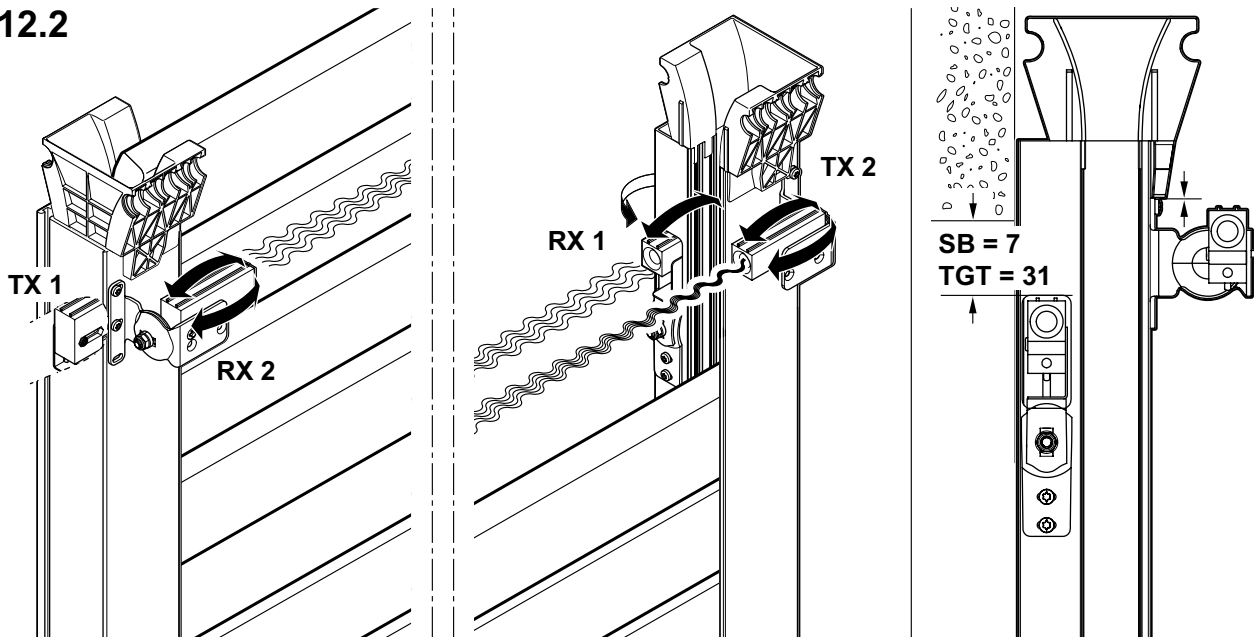

4.4 Control system and control elements

NOTE:

- Only attempt to carry out the electrical installation if you are a qualified electrician or have received adequate instruction from a qualified electrician. More specifically, you must possess the following qualifications:
 - You must recognise the hazards that electricity can cause.
 - You must be familiar with the applicable electrotechnical regulations.
 - You must be able to use and take care of the safety equipment.
 - You know how to give first aid.
- In addition, observe the following instructions:
 - Instructions for fitting, operating and service of the door control
 - Instructions for installation of electrical connections
 - Instructions for fitting additional electrical control elements
- Make sure that the electrical installation complies with the applicable safety requirements.
- Only fit the control and control elements under the following prerequisites:
 - The control is within sight of the door.
 - The control elements are out of reach of children at a height of at least 1500 mm.

ATTENTION
<p>External voltage or lead damage</p> <p>Electronics can be destroyed by external voltage or damage to the connecting leads.</p> <ul style="list-style-type: none"> ▶ Do not apply any external voltage to the connecting terminals of the control. ▶ Never pull on the connecting leads of the electrical components.

5 Initial start-up

CAUTION
<p>Defective door systems</p> <p>Putting a defective door system into service can lead to injuries and door system damage.</p> <ul style="list-style-type: none"> ▶ Before putting the door into service, check that it is in good working order and free of defects. ▶ Do not put the door system into service if it is defective.

5.1 Spring tension

Open and close the door with the operator disengaged. The door curtain must remain in place at any opening height.

CAUTION
<p>Too low spring tension</p> <p>If the spring tension is too low, the door curtain may fall down. There is a danger of injury and the door system can get damaged.</p> <ul style="list-style-type: none"> ▶ Move the door into the Open end-of-travel position and increase the spring tension by changing the position of the spring in the locking strip.

ATTENTION
<p>Too high spring tension</p> <p>Spring tension that is too high may lead to damage to the door system.</p> <ul style="list-style-type: none"> ▶ Move the door into the Open end-of-travel position and decrease the spring tension by changing the position of the spring in the locking strip.

5.2 End-of-travel positions

The door's end-of-travel positions are set at the operator or the control.

NOTE:

Observe the instructions for the operator and control.

5.3 Test run

After fitting is complete, test the functional safety in accordance with the inspection plan (see 7 *Inspection and maintenance on page 41*).

Verify in the test log book (dated and signed) that a test run has been successfully completed.

On completing installation, a test run and the inspection, hand the entire door documentation over to the owner of the door system.

6 Operation

6.1 Safety instructions for door operation

NOTE:

As the operator or owner of the door system, you are responsible for ensuring that all applicable regulations are observed and complied with. You can find the applicable regulations in 1.3 *Standards and directives to be observed on page 2*.

CAUTION

Danger of injury due to incorrect handling of door system

Handling the door system incorrectly can lead to injury. Observe the following safety instructions.

- ▶ You are responsible for ensuring that only suitably instructed persons operate the door. A person is considered instructed (according to EN 12453) if he/she fulfils the following criteria:
 - He/she has been shown how to operate the door safely.
 - He/she has received permission from you to use the door system.
- ▶ You are responsible for ensuring that children cannot operate the door system, neither via the control nor the control elements.
- ▶ Wait until the door has come to a standstill before walking/driving into the door's area of travel.
- ▶ Never use the door to lift objects and/or persons.
- ▶ Whenever driving in or out of the opening, always check that the door curtain has travelled up far enough to provide the necessary passage height.
- ▶ Only ever operate the door system when all the protective devices and safety equipment are fitted and are in perfect working order.
- ▶ Do not dismantle or alter any of the protective devices. Do not put any of the protective devices out of operation.

ATTENTION

Damage due to incorrect handling of the door system

Handling the door system incorrectly can lead to damage to the door system. Observe the following safety instructions.

- ▶ Protect the door from aggressive and caustic substances.

CAUTION

Exceeding the Closed end-of-travel position

Exceeding the Closed end-of-travel position can lead to the destruction of the door curtain and serious injuries.

- ▶ Do not operate the door after exceeding the Closed end-of-travel position.
- ▶ Have the door examined by a specialist.

NOTE:

Make sure you are familiar with the way the door control, the control elements and the operator work, so you know how to operate these devices properly (see instructions).

6.2 Emergency-OFF

Proceed as follows during emergency off situations for doors with a WA 300 R S4 / WA 300 AR S4:

- ▶ Pull out the CEE mains plug to disconnect from the power supply.
or
- ▶ Actuate the red main switch or the emergency-OFF button.

6.3 Emergency operation in case of operator malfunction

If the operator malfunctions or fails, you can manually open and close the door in emergency operation. Disengage the operator using the maintenance release or secured release (optional).

NOTE:

In this regard, follow the instructions in the manual supplied with the WA 300 R S4 / WA 300 AR S4.

6.4 Operating conditions

The door system is intended for the following operating conditions:

Temperature range: -20 °C to +60 °C
Relative humidity: 0 % to 60 %

6.5 Wind load

ATTENTION

Damage to the door system due to wind load

The door curtain deflects under wind loads.

Door function is not guaranteed and door parts may be damaged during heavy wind loads.

- ▶ Never open or close the door during a wind force exceeding 8 Beaufort.

The following conditions may arise due to high wind loads:

- The door curtain can deform permanently.
- The door construction can suffer damage.

Follow these steps after a heavy wind load:

- Inspect the operational safety of the door system (see *7.2 Malfunctions and damage remedy on page 41*).
- Repair storm damage before putting the door system back into service (see *7.6 Storm damage on page 41*).

6.6 Information on the product characteristics

6.6.1 Abrasion and pressure marks

The design of the TGT rolling shutter represents state-of-the-art technology. Pressure marks and abrasive wear, particularly on the top profiles, are design-related and cannot be avoided.

- ▶ In order to avoid excessive abrasion, remove any soiling (e.g. sand, dust, plastic particles etc.) at regular intervals.

NOTE:

Follow the directions for door cleaning and care (see *8 Cleaning and care on page 43*).

6.6.2 Noise

Opening and closing the door produces a certain degree of noise related to the design. The noise emission does not exceed 70 dB(A).

Increased noise emission could occur under the following conditions:

- Extensive soiling of the door curtain (see 8 *Cleaning and care on page 43*)
- Incorrectly fitted door system

6.6.3 Windows

If conditions are damp and temperatures unfavourable, this can cause the window panes to mist up. This moisture will eventually dissipate and does not cause any long-term damage.

6.6.4 Deflection

The door curtain is flexible. A slight deflection of the door profiles in the unloaded state does not constitute grounds for concern nor does it impair the function.

Door width [mm]	Deflection [mm]
2000	2
3000	5
4000	8
5000	13

Deflection can be significantly increased under heavy wind loads.

7 Inspection and maintenance

7.1 Obligation to inspect and maintain

NOTE:

As the owner or operator of the door, you must have the system inspected and maintained by a specialist (competent person as defined in EN 12635) every 6 months.

 CAUTION
<p>Ignoring the obligation to inspect and maintain</p> <p>The following problems may occur if you do not have the door inspected and maintained as specified:</p> <ul style="list-style-type: none"> • Risk of injury • Risk of damage • Nullification of the warranty <p>▶ Arrange for all the inspections and maintenance work to be carried out by a specialist company.</p>

7.2 Malfunctions and damage remedy

In the case of malfunctions call in a qualified specialist (competent person in accordance with EN 12635) immediately to inspect and repair the door system.

7.3 Original spare parts

Only use original spare parts. They always meet the technical requirements laid out by us.

7.4 Tension springs and cables

NOTE:

The spring assemblies, cables and cable return pulley are wearing parts. Replace the spring assemblies, cables and cable return pulley no later than after 40000 door cycles.

 WARNING
<p>Ignoring damaged spring assemblies and cables</p> <p>Damaged spring assemblies and cables may lead to injuries and damage.</p> <ul style="list-style-type: none"> ▶ Immediately exchange damaged spring assemblies and cables. ▶ Always exchange damaged spring assemblies and cables. ▶ Follow all the inspection and maintenance advice relating to accessories.

 WARNING
<p>Use of incorrect spring assemblies and cables</p> <p>The use of incorrect spring assemblies and cables may lead to injuries and damage.</p> <ul style="list-style-type: none"> ▶ Only use the spring assemblies and cables listed on the data label. ▶ Follow all the inspection and maintenance advice relating to accessories.

 WARNING
<p>Exchanging spring assemblies or cables without using the security bolts</p> <p>Exchanging spring assemblies or cables without using the security bolts in the side guides may lead to injuries and damage.</p> <ul style="list-style-type: none"> ▶ Only exchange the spring assemblies or cables if the door curtain is in the Open end-of-travel position, the grip handles have been fitted to the bottom profile and the security bolts have been inserted in the side guides. ▶ Follow all the inspection and maintenance advice relating to accessories.

7.5 Operator power

The voltage of the electricity supply must be 95% of the operator's operating voltage. Any voltage lower than this can lead to malfunctions in operating the door.

7.6 Storm damage

Examine the following parts of the door system after wind loads of 8 Beaufort or greater:

Component	Test criterion	OK
Door curtain	1. No permanent deformations which could impair operation of the door (e.g. curtain rolling up unevenly or obliquely)	
End pieces with wind locks	1. No torn-out wind locks 2. No visible strain on the connection between wind lock end pieces and profile	
Side guides	1. No deformation 2. Firmly seated on the building structure	

- If the wind locks have torn out, replace the end pieces and the profiles concerned.

7.7 Inspection and maintenance plan

NOTES:

Please observe the following:

- The applicable regulations governing work safety when carrying out inspections and maintenance
- The notes in *2 Basic safety instructions on page 4*
- All inspection and maintenance advice relating to accessories

 WARNING
<p>Actuation by other persons</p> <p>Actuating the door system while inspecting or performing maintenance work can lead to injuries and damage.</p> <p>► Make sure that whenever checks, maintenance work and cleaning are being carried out, the door system cannot be actuated by other persons.</p> <p>► Follow all the inspection and maintenance advice relating to accessories.</p>

Only inspect and maintain this door if you are qualified to do so, i.e. are a competent person as defined in EN 12635. In other words, you have the suitable training, specialist knowledge and practical experience to allow you to carry out inspection and maintenance correctly and safely.

Component	Test criterion	OK
Side guides	1. No deformation 2. Undamaged 3. Firmly fastened to the building structure 4. Tightening torque of the fixing material meets the requirements	
Plastic runners	1. No deformation 2. Undamaged 3. Bristle seal fitted 4. Bristle seal has not been pulled out	
Funnel	1. Undamaged 2. Firmly seated on the side guide	

Component	Test criterion	OK
Data label	1. Available 2. Undamaged	
Door curtain	1. No collision damage 2. No increased abrasive wear or pressure marks 3. Undamaged 4. No unusual soiling (sand, chemicals) 5. Curtain runs smoothly into the side guides	
End pieces	1. Complete 2. Undamaged 3. Firmly seated on the profiles 4. Fixing material undamaged	
Wind locks	1. Complete 2. Do not touch each other when door curtain rolls up	
Screw-on fixing brackets	1. Complete 2. Not bent up 3. No slotted holes present 4. Firmly seated on the barrel 5. Fixing material complete	
Bottom profile	1. Undamaged 2. Grip handles undamaged and firmly fitted	
Bottom seal	1. Undamaged	
Support brackets	1. No deformation 2. Fixing material complete 3. Tightening torque of the fixing material meets the requirements	
Operator	1. No unusual sounds when running 2. No oil leaks 3. Undamaged control chain 4. Chain tension meets the requirements 5. Fixing material complete 6. Tightening torque of the fixing material meets the requirements	
Barrel	1. Horizontally balanced and aligned 2. Undamaged 3. Smooth running 4. No subsequent changes 5. Curtain rings undamaged	
Shafts	1. Firmly seated on the barrel 2. Locking rings present	
Cable cone	1. Undamaged 2. Firmly seated on the shaft journals	
Pulley	1. Undamaged 2. Moves smoothly on the axle	

Component	Test criterion	OK
Cable axle	1. Free of soiling 2. Greased	
Cables	1. Undamaged 2. Complete 3. Run parallel without twisting	
Spring assemblies	1. Undamaged 2. Complete 3. Correspond to the information on the data label 4. Spring tension has been correctly set	
Operator WA 300 R S4 / WA 300 AR S4	1. Housing undamaged 2. No moisture in the control 3. CEE plug is easy to disconnect 4. At the CLOSE end-of-travel position no more than 3 - 4 profiles will travel into one another	
Wiring³	1. Conforms to standard 2. Leads undamaged 3. Cable glands OK	
Power limit	1. In perfect working order 2. Adjustment of the reversal limit complies with the requirements	
Radio control²⁾	1. In perfect working order	
Lockable bottom profile²⁾	1. Undamaged 2. In perfect working order 3. Safety switch at correct setting and properly connected	
Trap guard / PVTGT²⁾	1. Undamaged 2. Fixing material complete 3. Tightening torque of the fixing material meets the requirements	

1) This component is not used on a rolling grille or the test criterion is not applicable
2) Optional components

8 Cleaning and care

ATTENTION
<p>High-pressure cleaner</p> <p>Cleaning the door system with a high-pressure cleaner can lead to door system malfunctions and damage.</p> <p>▶ Do not use any high-pressure cleaners for cleaning the door system.</p>

8.1 Door curtain

- To preserve the surface characteristics, cleaning must be carried out at least every 3 months.
- Use warm water together with a neutral, non-abrasive cleaning agent (household detergent, pH value 7).
- To clean the surface, use only a soft cloth or a window leather.
- Rinse off any dirt and dust particles with clear water.

ATTENTION
<p>Rubbing panes dry</p> <p>Scratches may occur.</p> <p>▶ Do not rub panes dry.</p>

8.2 Safety equipment and photocells

Clean the lenses and reflectors regularly with a soft, dry, lint-free cloth. Soiled optics can impair function.

9 Extension and conversion

 WARNING
<p>Use of non-authorized components</p> <p>Non-authorized components could overload the door construction. This could lead to serious injuries and damage.</p> <p>▶ Any conversion of the door system requires the express permission of the manufacturer.</p> <p>▶ Only use components that have been approved by the manufacturer.</p>

NOTE:

Carrying out any structural alterations to the product without the manufacturer's permission renders the warranty and product liability null and void.

10 Dismantling

NOTE:

When dismantling the system, observe the applicable occupational safety rules and regulations.

1. Open the door completely.
2. Remove the stops on the bottom profile.
3. Carefully roll up the door by hand.
4. Tape round the door barrel several times with strong adhesive tape (e.g. packing tape) to prevent it from unrolling.
5. Drive a forklift with suitable pallet underneath the door barrel so that the door barrel lies on the pallet.
6. Loosen the fastening on the support brackets and side guides.
7. Lower the door system slowly using a suitable lifting device (forklift, crane).
8. Dismantle the door into component parts and dispose of them properly.

Dissemination as well as duplication of this document and the use and communication of its content are prohibited unless explicitly permitted. Noncompliance will result in damage compensation obligations. All rights reserved in the event of patent, utility model or design model registration. Subject to changes.

HÖRMANN KG Verkaufsgesellschaft
Upheider Weg 94-98
33803 Steinhagen, Germany
www.hoermann.com