

TDOKU 9006857-EN / 06.2025

EN

Fitting, operation and maintenance instructions

Rolling shutter DD and rolling grille DD

Table of contents

1	About these instructions.....2
1.1	Intended use.....2
1.2	Further applicable documents.....2
1.3	Standards and directives to be observed2
1.4	Warning labels used3
1.5	Symbols used.....3
1.6	Abbreviations used.....4
2	Basic Safety Instructions.....4
2.1	Transport4
2.2	Fitting, testing and maintenance4
2.3	Operation.....4
3	Warranty5
4	Assembly.....5
4.1	Testing prior to fitting the door5
4.2	Door components.....5
4.3	Fitting dimensions7
4.4	Fitting steps.....7
4.5	Control system and control elements.....38
5	Initial start-up.....38
5.1	End-of-travel positions38
5.2	Lintel seal.....38
5.3	Test run38
6	Operation.....39
6.1	Safety instructions for door operation.....39
6.2	Emergency-off39
6.3	Emergency operation in the case of safety equipment malfunctioning.....39
6.4	Operating conditions39
6.5	Operating cycles.....39
6.6	Wind load40
6.7	Information on the product characteristics40
7	Inspection and maintenance40
7.1	Obligation to inspect and maintain.....40
7.2	Malfunctions and damage remedy.....40
7.3	Original spare parts40
7.4	Wearing parts41
7.5	Operator power41
7.6	Storm damage.....41
7.7	Locking cylinder41
7.8	Inspection and maintenance plan41
8	Cleaning and care.....43
8.1	Door curtain.....43
8.2	Lintel seal.....43
8.3	Safety equipment and photocells.....43
9	Extension and conversion43
10	Dismantling43

1 About these instructions

Dear Customer,

We are delighted that you have decided to choose a Hörmann product.

These instructions are original instructions as outlined in the EC Directive 2006/42/EC. Read and follow these instructions carefully, paying particular attention to section on page . They provide you with important information on the safe fitting and operation, as well as proper care and maintenance, of your door system.

Competent operation and proper maintenance influence the performance and availability of your door system to a considerable degree. Operating errors and inadequate maintenance will lead to avoidable failures. Only competent operation and proper maintenance will guarantee satisfactory, long-term operational safety.

The section *Operation* on page 39 contains all the information necessary to ensure correct operation. The door system may only be operated by persons who have been instructed in its proper use. Instruction is provided by the fitting personnel following the initial start-up procedures.

Section on page sets out and describes all the inspections and maintenance work to such an extent that a specialist is capable of carrying out maintenance. These maintenance instructions do not constitute work instructions permitting more extensive repairs to be carried out. Our Customer Service will be happy to carry out this work for you.

Should you have any questions on having read through these instructions, please feel free to consult our Customer Service.

1.1 Intended use

The rolling shutter DD and rolling grille DD are only suitable for the following applications:

- Operation in industrial and commercial applications
- Closing passage openings
- Closing openings with a vertically guided door leaf

Using the door for purposes other than or exceeding those stated above is prohibited.

1.2 Further applicable documents

In addition to these instructions, observe the following documents:

- Instructions for fitting, operating and service of the door control
- Instructions for fitting additional electrical control elements
- Additional sheets for special components or special equipment

1.3 Standards and directives to be observed

1.3.1 Fitting and maintenance

At the least, observe the following European standards and directives, as well as all country-specific safety regulations, standards and provisions:

305/2011	Construction Products Regulation
2006/42/EC	Machinery Directive

2006/95/EEC	Low Voltage Directive
2004/108/EC	Electromagnetic compatibility
EN 12453	Industrial, commercial and garage doors and gates – Safety in use of power operated doors – Requirements and test methods
EN 12604	Industrial, commercial and garage doors and gates – Mechanical aspects – Requirements and test methods
EN 12978	Doors – Protective Devices for Power-Operated Doors – Requirements and Test Methods
EN 13241	Industrial, commercial and garage doors and gates – Product standard – Part 1: Products without fire resistance or smoke control characteristics
EN 60204-1	Electrical Machine Equipment
EN 60335-1	Household and similar electrical appliances – Safety

For safety and health at work, observe at least the following rules and regulations or comparable national regulations, e.g.:

ASR A1.7	Power-Operated Windows and Doors
DGUV V3	General Regulations – Electrical Installations and Equipment

1.3.2 Operation

At the least, observe the following European standards, as well as country-specific safety regulations, standards and provisions:





EN 12453	Industrial, commercial and garage doors and gates – Safety in use of power operated doors – Requirements and test methods
----------	---

For safety and health at work, observe at least the following rules and regulations or comparable national regulations, e.g.:













ASR A1.7	Power-Operated Windows and Doors
DGUV V3	General Regulations – Electrical Installations and Equipment

1.4 Warning labels used

ATTENTION	Indicates a danger that can lead to damage or destruction of the product.
------------------	--

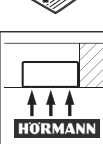
	The general warning symbol indicates a danger that can lead to injury or death . In the text, the general warning symbol will be used in connection with the caution levels described below. In the illustrated Section, an additional instruction refers back to the explanation in the text.
 CAUTION	Indicates a danger that can lead to minor or moderate injuries.
 WARNING	Indicates a danger that can lead to death or serious injuries.
 DANGER	Indicates a danger that leads directly to death or serious injuries.

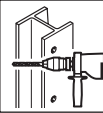
1.5 Symbols used

-  Important note for avoiding damage to property
-  Correct arrangement or activity
-  Incorrect arrangement or activity
-  See text section
-  See illustrated section
-  See fitting dimension sheet
-  See separate fitting instructions for the control or for the additional electrical control elements
-  See additional sheets
-  Additional posts marked in the table of fitting dimensions
-  Optional components
-  Drilling in steel
-  Drilling in concrete

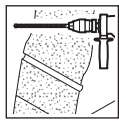

Drilling in brickwork



Drilling in timber

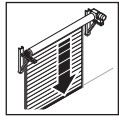

Door closed



Trade fairs



Remove and dispose of component or packaging



Remove residue



Tighten the screws by hand



Plug-and-screw fitting: see information in the text

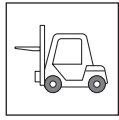

Use a suitable lifting device (e.g. forklift, crane)



Check

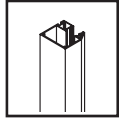

without subframe profiles

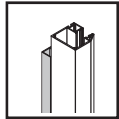

1 subframe profile

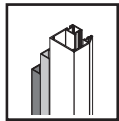

2 subframe profiles

1.6 Abbreviations used

EN	European standard
----	-------------------

FFL	Finished floor level (FFL)
-----	----------------------------

2 Basic Safety Instructions

Keep these instructions safe at the place of use together with all the documentation for the door system.

WARNING

Incorrect fitting or incorrect handling

Incorrect fitting or handling of the door could result in serious injury.

- ▶ Follow all the instructions provided in this manual.

2.1 Transport

ATTENTION

Transporting the door barrel without a special pallet

The door may be damaged if transported without a pallet.

- ▶ The door barrel must only ever be transported on the special pallet.

2.2 Fitting, testing and maintenance

Fitting, testing and maintenance may only be carried out by a specialist.

- For your own safety, have the product installed by an approved specialist company.
- Do not alter or remove any functional parts! You otherwise risk putting important safety components out of action.
- Always obtain the permission of the structural engineer before fastening the door system to supporting structural elements.
- Throughout fitting, protect the door system components, especially the door curtain, against dirt and damage.
- Make sure that whenever checks, maintenance work and cleaning are being carried out, the door system cannot be actuated by other persons.

WARNING

Changes to the door construction

Additional components could overload the door construction and lead to serious injuries.

- ▶ Do not attach any additional components.

2.3 Operation

- The door system may only be operated by persons who have been instructed in its proper use. Instruction is provided by the fitting personnel following the initial start-up procedures.
- The door system opens and closes vertically upwards and downwards. When operating the door, make sure that neither persons – children in particular – nor objects are located within the door's area of travel.

 WARNING
Defective door systems
A fault in the door system can lead to serious injuries.
▶ Only ever use the door when it is technically sound and in perfect working order.

3 Warranty

For the warranty, the generally recognised terms and conditions or those agreed in the delivery contract apply. The warranty will no longer apply under the following conditions:

- You damage the door due to a lack of knowledge of the information provided in these Instructions for Fitting, Operating and Maintenance.
- You carry out structural modifications without our prior approval.
- You undertake improper installation or arrange for same to be carried out by others, contrary to the installation guidelines we have set out.
- You damage the door due to improper operation (see section on page).
- You are using the door for purposes for which it was not intended (see section *Intended use* on page 2).
- You fail to have the door inspected and maintained at regular intervals as stipulated (see section *Obligation to inspect and maintain* on page 40).

4 Assembly

NOTICES:

Refer to the following documents:

- Enclosed additional sheets for special components or special equipment
- The fitting notes in section *Basic Safety Instructions* on page 4
- The fitting and operating safety requirements as described in section *Standards and directives to be observed* on page 2

All specified dimensions in the illustrated section are in [mm].

4.1 Testing prior to fitting the door

4.1.1 Prerequisites for the building structure

Fit the door only if the following prerequisites are fulfilled:

- There is a second exit in the room where the door is to be fitted.
- A water run-off has been installed outside in front of the bottom seal.
- A metre line is present.
- The hall floor is finished.
- The building structure is level (tolerance ± 5 mm).

4.1.2 Minimum requirements for the building structure

- Concrete
 - Strength class C 20/25
 - Thickness 140 mm

- Standard EN 206-1
- Steel
 - Strength class S235-JRG2
 - Thickness 5 mm
 - Standard EN 10027-1
- brickwork
 - Strength class 12 / mortar group II
 - Thickness 240 mm
 - Standard DIN 1053-1
- Timber
 - Coniferous wood C24 / quality category II
 - Thickness 120 mm
 - Standard DIN 1052 (EC5)

4.1.3 Test dimensions

p1	Clear width of the building opening
p2	Clear height of the building opening
p3	Min. sideroom for support bracket on left
p4	Min. sideroom for side guide on left
p5	Min. sideroom for support bracket on right
p6	Min. sideroom for side guide on right
p7	Min. headroom
p8	Min. fitting depth
p9	Bottom support bracket dimension on left
p10	Bottom support bracket dimension on right
p11	Ordering size: door width
p12	Ordering size: door height
p13	Available sideroom on left
p14	Available sideroom on right
p15	Available headroom

Curtain cover

pv0.00	Total width of curtain cover
pv0.01	Fitting depth of curtain cover
pv1.00	FFL to top edge of barrel casing support bracket
pv1.01	Centre of door to outer edge of curtain cover on operator side
pv1.02	Centre of door to outer edge of curtain cover on bearing side
pv1.03	Distance from outer edge of curtain cover to centre of centre support bracket or distance from centre of centre support bracket to centre of centre support bracket
pv1.04	FFL to bottom edge of operator cover

4.2 Door components

Check the following points before fitting:
The delivery is complete.
All the components are damage-free.

4.2.1 Fixing points

 WARNING
Danger of damage and falling if the specified fixing points are not used
<ul style="list-style-type: none"> ▶ Fix the door system at all of the fixing points specified in these instructions and the table of fitting dimensions. ▶ Do not deviate from the tolerances specified in the table of fitting dimensions for the fixing point positions.

4.2.2 Fixing material

 WARNING
Danger of damage and falling when unsuitable fixing material is used
<ul style="list-style-type: none"> ▶ If used as an external rolling shutter or in car wash halls, only use stainless steel fixing material to fix the support brackets. ▶ When fastening the door system to a building structure made of gas concrete, always provide a steel base construction.

NOTICES:

- Check whether the fixing material intended for use with the existing building structure has been included / is available.
- Use only the fixing material specified in the illustrated section.

Plug-and-screw fitting

NOTICES:

Only fit the plugs if the following prerequisites are fulfilled:

- The building structure is at least 30 mm thicker than the depth of the drill hole.
- The edge distance from the drill hole to the building structure edge is at least 50 mm.

Only use new plug sleeves.

Procedure:

1. Drill the hole at a right angle to the surface.
2. Remove the drilling dust from the drill hole.
3. Insert the plug sleeve into the drill hole by lightly hammering in with a mason's mallet until the collar is flush with the building structure or structural component.
4. Tighten the screw until the component fits snugly against the building structure.
The following conditions must be met:
 - It must be difficult to turn the screw further.
 - The plug sleeve must not turn with the screw.

4.2.3 Protective films

ATTENTION
Malfunction due to protective film not being removed
▶ Remove the protective film applied at the factory before fitting all door components.

4.2.4 Fitting aids

NOTE:

Use suitable tools and appropriate equipment for fitting the door system.

Have the following aids ready:

- A suitable lifting device (forklift, crane) to lift the door curtain onto the support brackets. Observe the overall weight of the door curtain stated in the data label.
- A suitable lifting platform or scaffold

4.2.5 Welding

 WARNING
Danger of fire and explosions through welding work
Welding work can lead to fire and explosions caused by gas, dust, vapour and smoke.
Take the following precautions:
<ul style="list-style-type: none"> ▶ Do not carry out any welding, grinding or work involving burning without permission. ▶ Before carrying out any welding, grinding or work involving burning, clean the door system to remove any dust or combustible substances. ▶ Make sure that there is sufficient ventilation. ▶ Make sure you have a fire extinguisher ready. ▶ Observe the statutory fire alarm and fire-fighting regulations.

ATTENTION
Damage to plastic parts when welding
▶ Keep plastic parts away from the welding flame and protect them against heat effects in the proximity of the welding area.

NOTE:

Only carry out welding work if you are a qualified welder or have had equivalent training.

4.2.6 Additional door components

Before fitting the door, install the following components (if provided):

- Additional posts
- Weld-on plates
- Fascia panel

During fitting, observe the data stated in the following documents:

- Fitting dimension sheet
- Additional sheets

4.3 Fitting dimensions

m1.00	Reference plane finished floor level (FFL)
m1.01	Door width
m1.02	Door height
m1.03	Centre of door to fixing point of operator support bracket
m1.04	Centre of door to fixing point of bearing support bracket
m1.05	FFL to top fixing point of operator support bracket
m1.06	FFL to top fixing point of bearing support bracket
m1.07	Lintel to centre of barrel
m1.08	Support height
m1.09	Reveal to back edge of side guide
m1.10	Back edge of side guide on right to back edge of side guide on left
m1.11	FFL to lowermost fixing point of side guide
m1.12	Distance between side guide fixing points
m1.13	Bottom edge of lintel to bottom edge of lintel seal locating profile
m1.15	FFL to bottom fixing point of operator support bracket
m1.16	FFL to bottom fixing point of bearing support bracket
m1.17	Reveal to side guide fixing point
m1.18	FFL to centre of barrel
m1.19	Distance of top side guide fixing point
m2.00	Additional post width
m2.01	Additional post height
m3.00	Height of fascia panel
m3.01	Centre of door to fixing points of fascia panel
m3.02	FFL to bottom fixing point of fascia panel
m3.03	Distance from bottom fixing point of fascia panel to top fixing point of fascia panel
m4.00	FFL to bottom edge of weld-on plate on operator side
m4.01	FFL to bottom edge of weld-on plate on bearing side
m4.02	Reveal to inside edge of weld-on plate on operator side
m4.03	Reveal to inside edge of weld-on plate on bearing side
m4.04	Weld-on plate width
m4.05	Weld-on plate height

4.4 Fitting steps

Fit the door system using the following illustrations.

- Proceed carefully step by step.
- Observe all additional notes given.

0

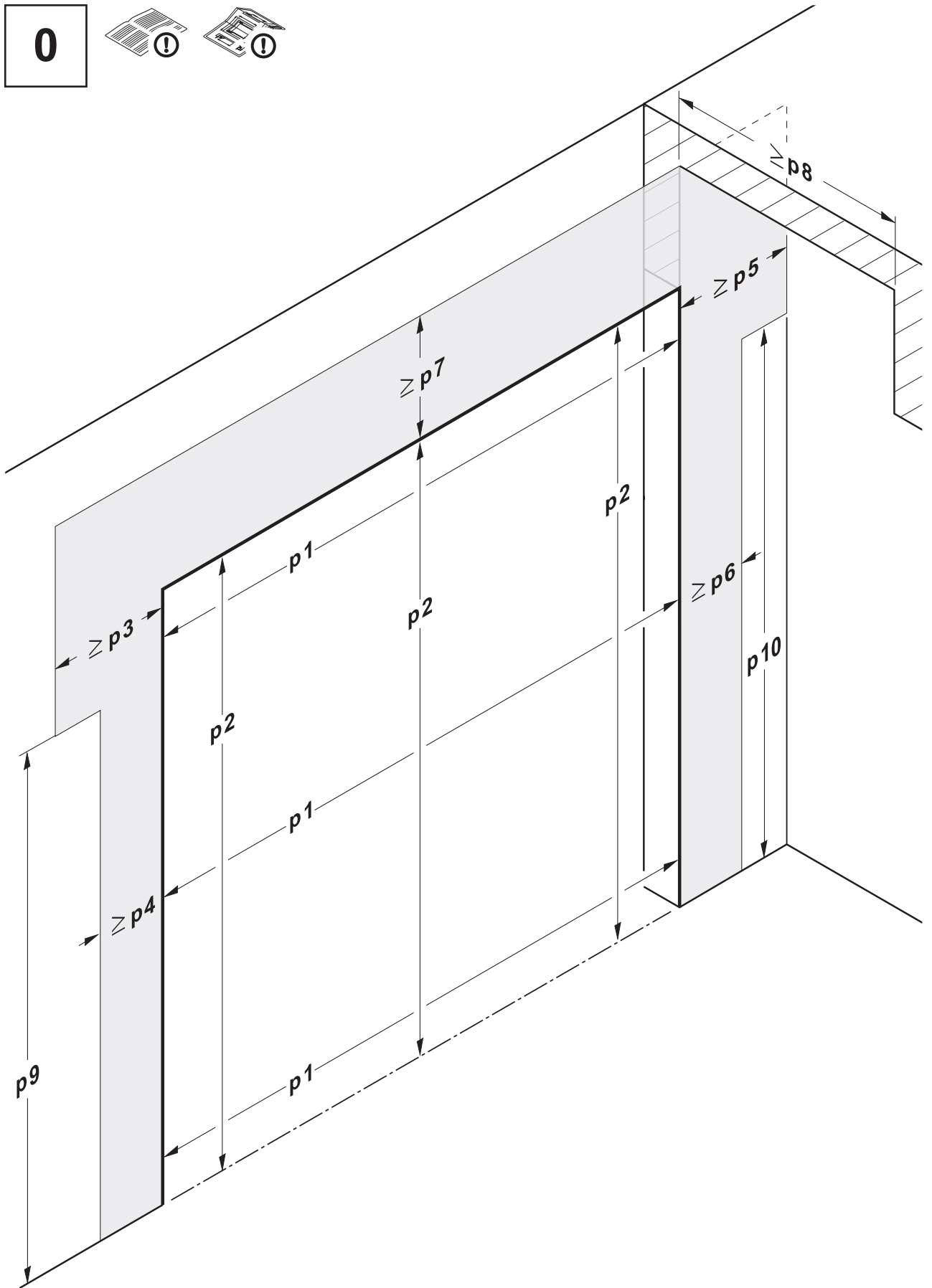

1

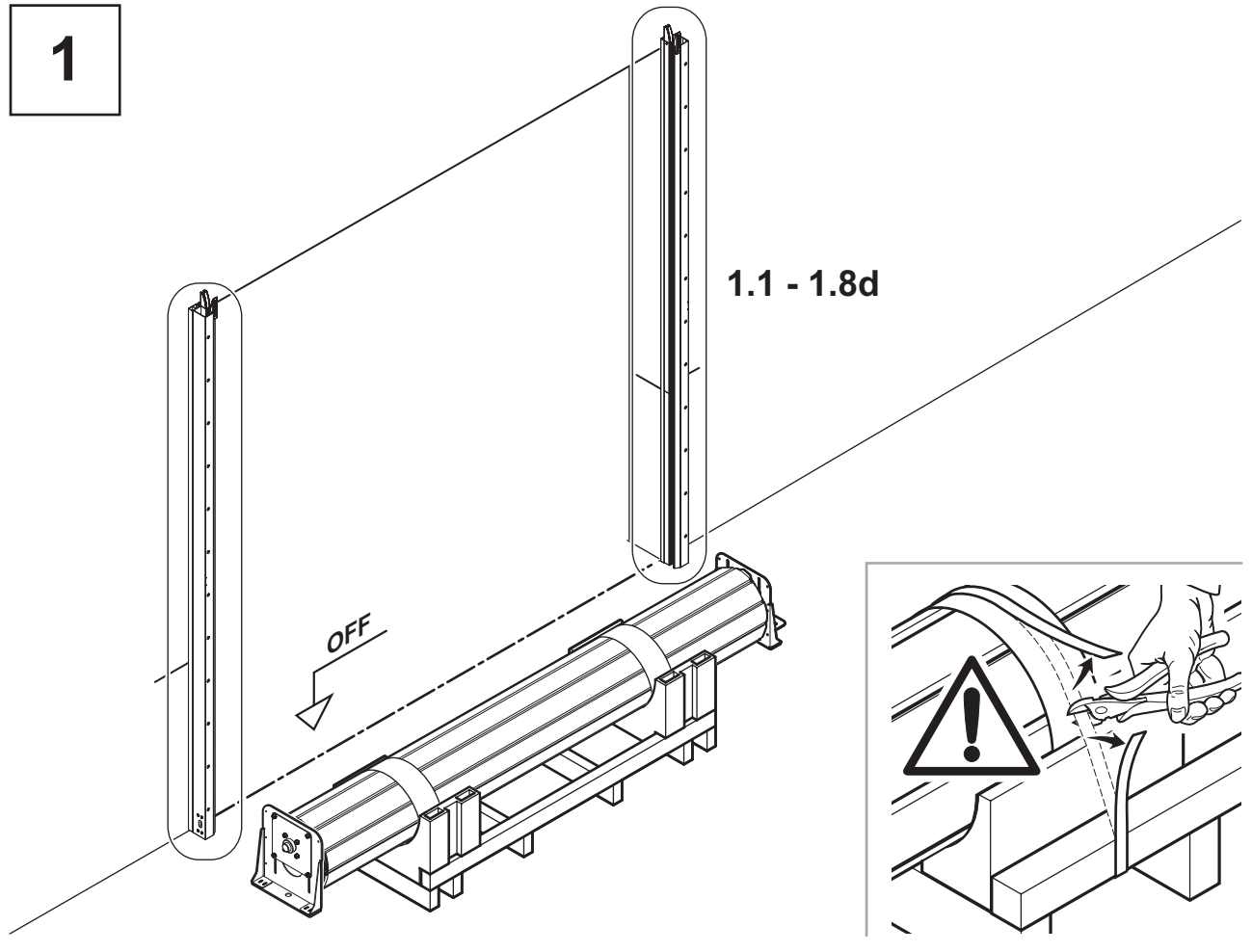

1.1

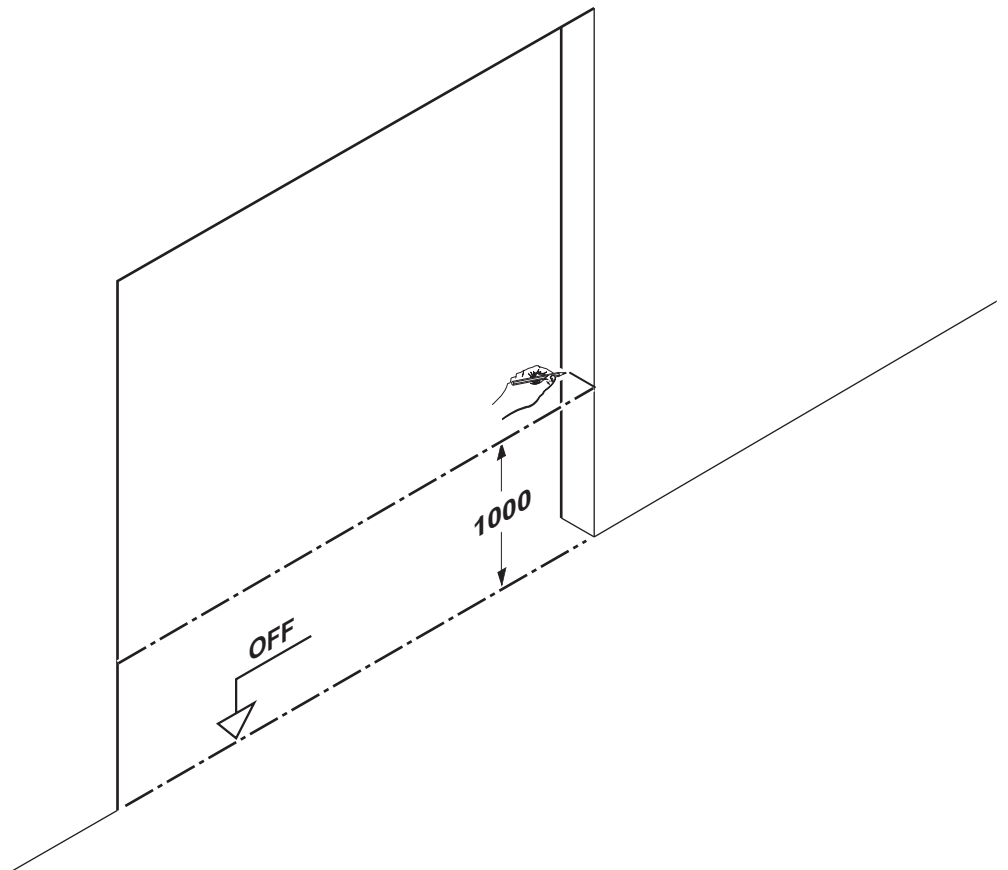

1.2



➔ 1.4

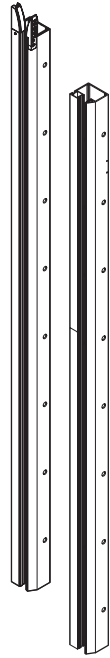

➔ 1.3

1.3

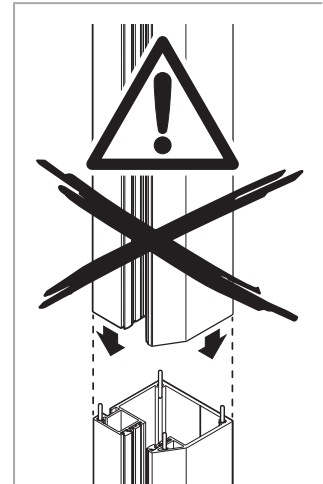
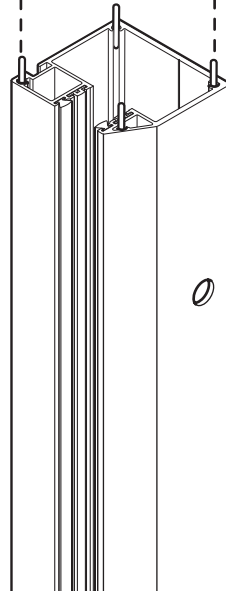
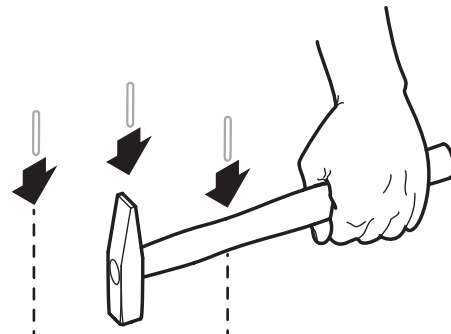

1.4

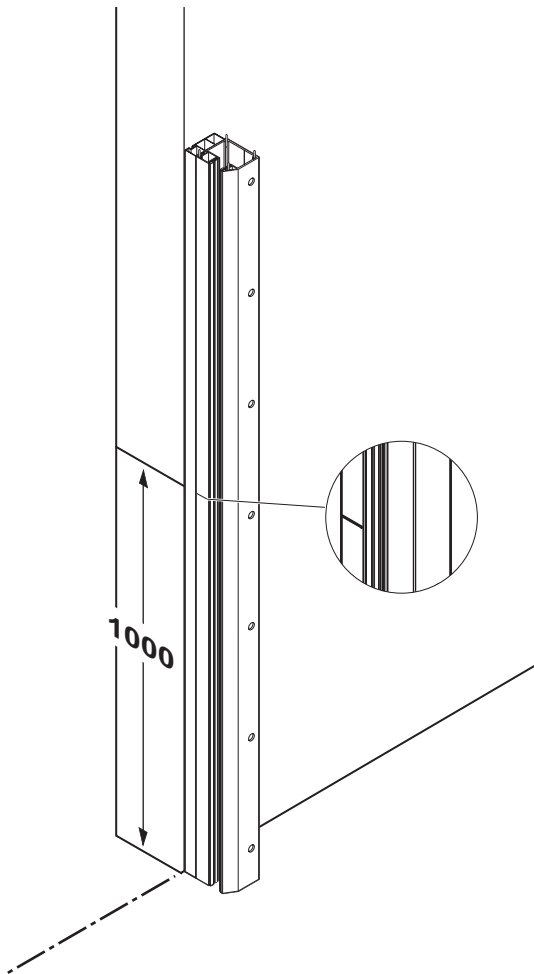

1.5

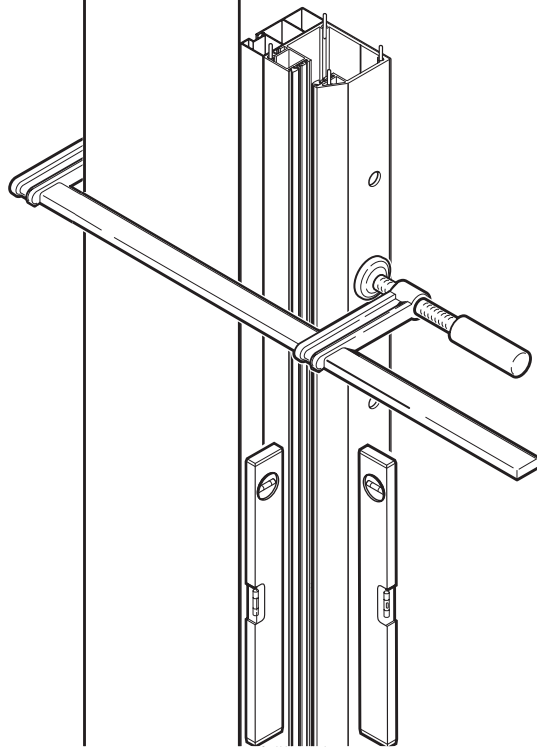

1.6

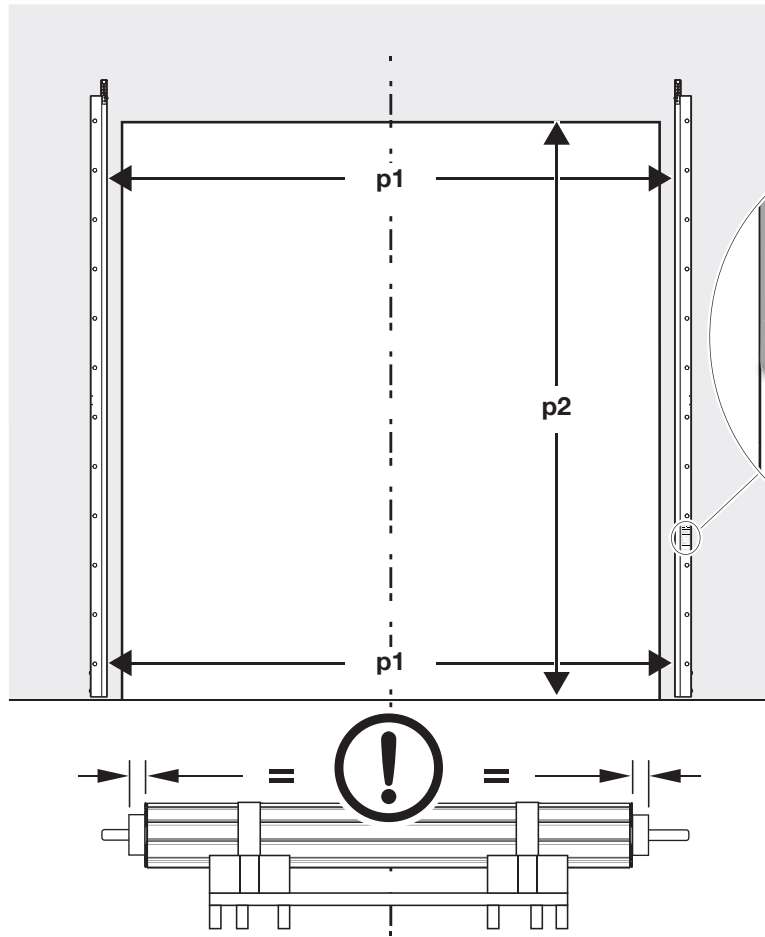

1.7

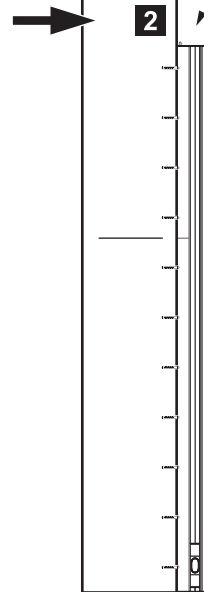
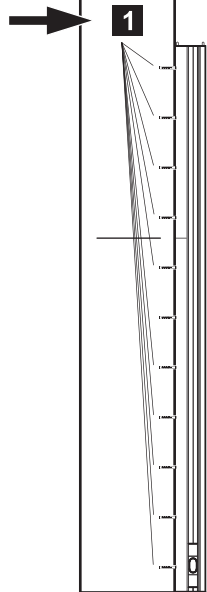
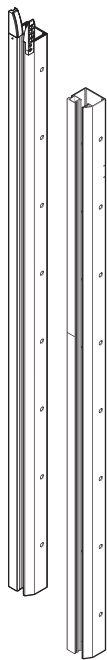

1.8a1

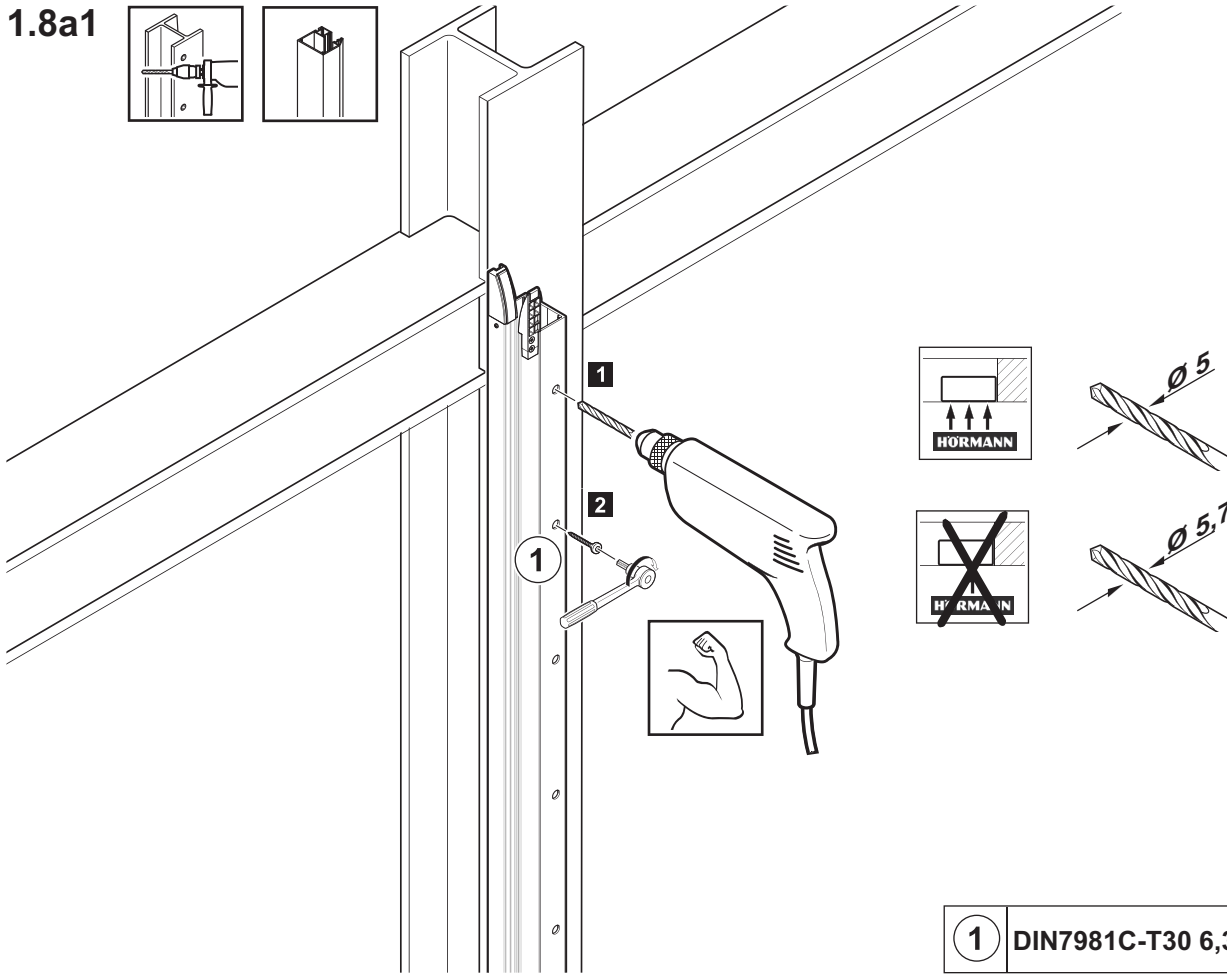
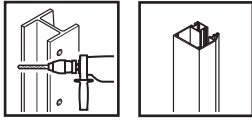

1 DIN7981C-T30 6,3x80

1.8b1

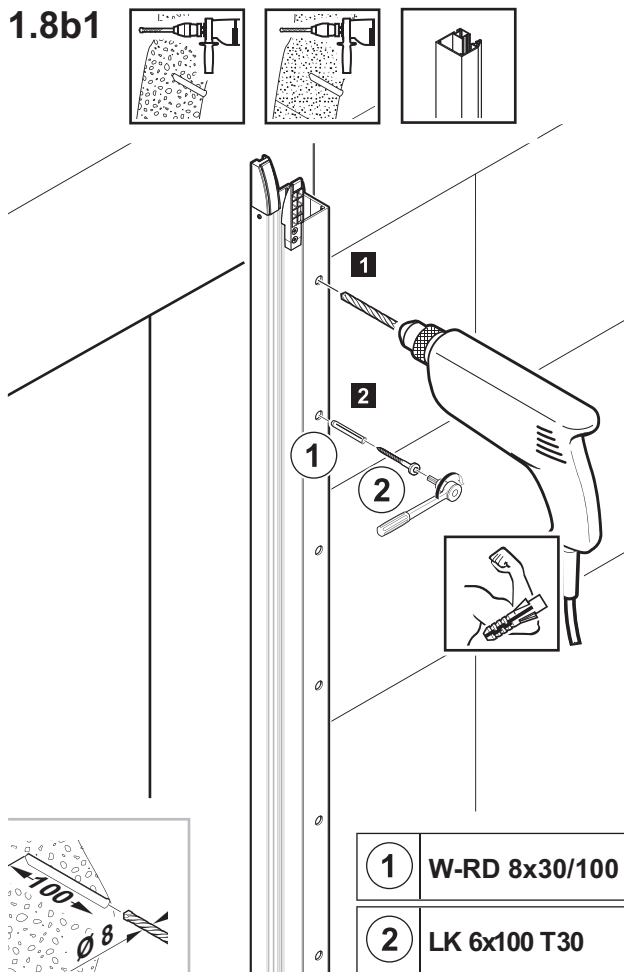

1 W-RD 8x30/100
2 LK 6x100 T30

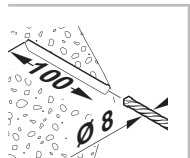

1.8c1

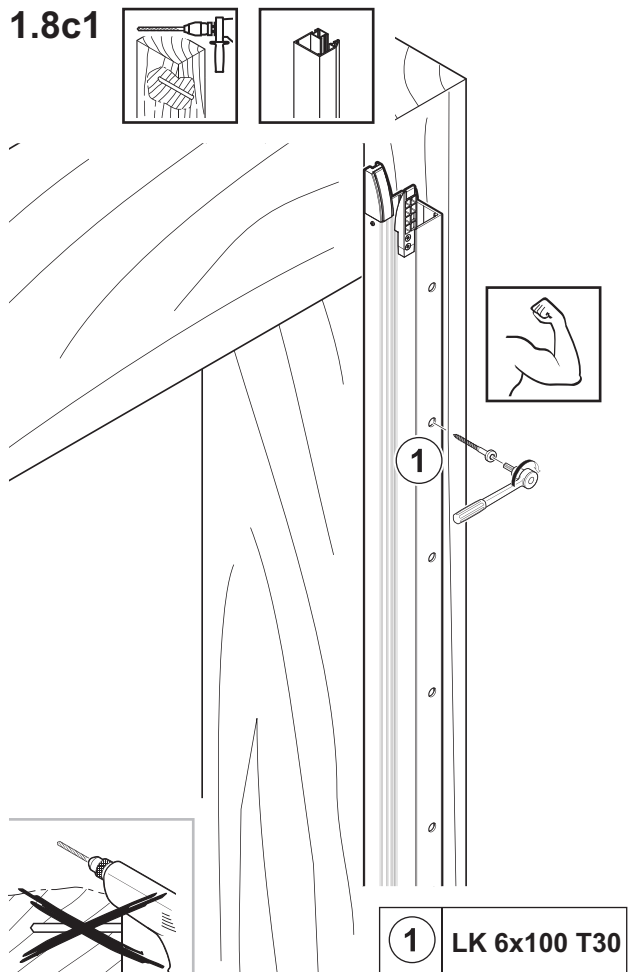
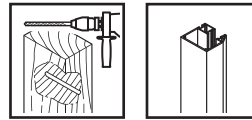

1 LK 6x100 T30

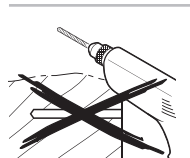

1.8a2

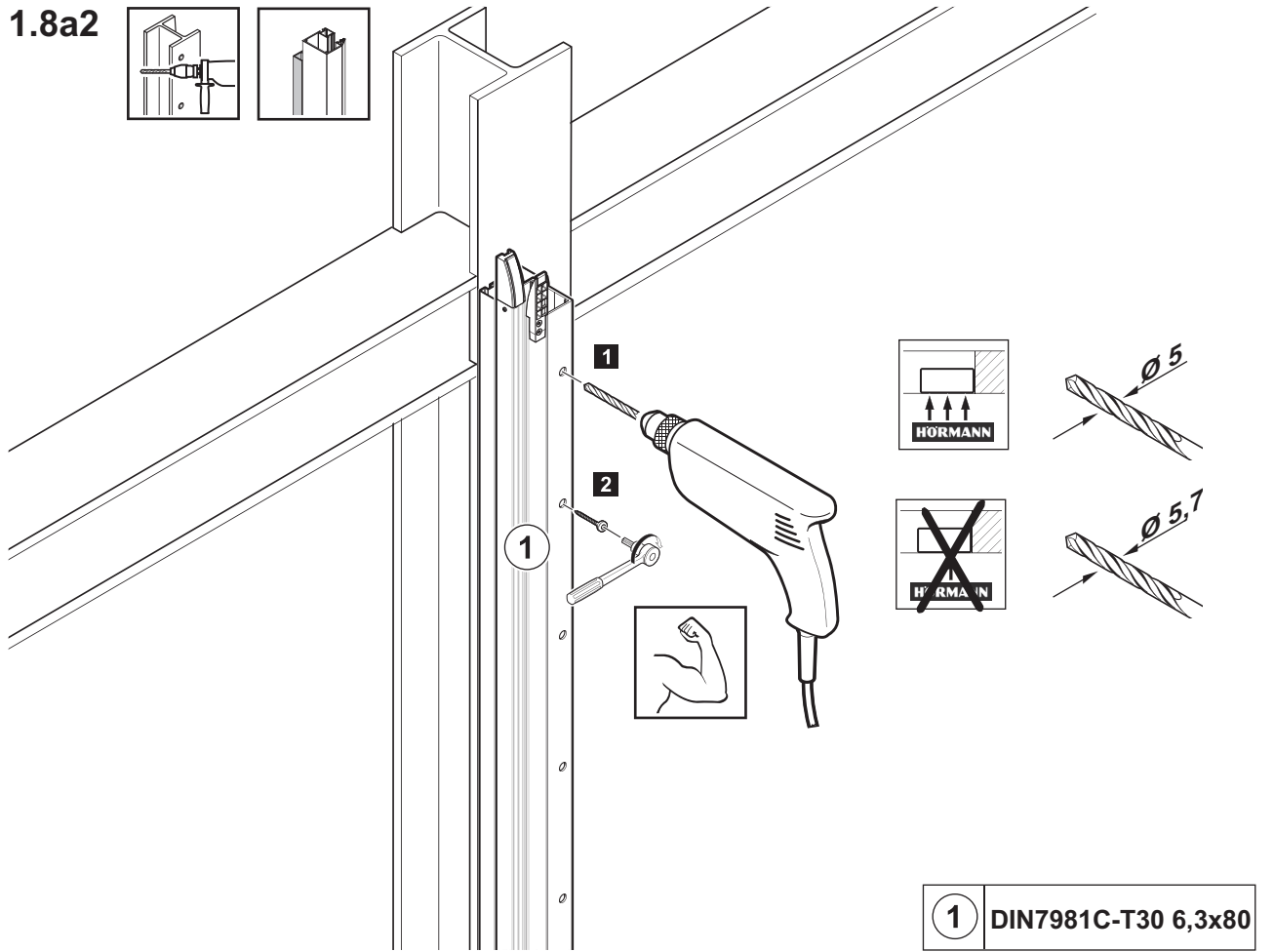
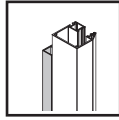
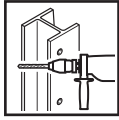

1 DIN7981C-T30 6,3x80

1.8b2

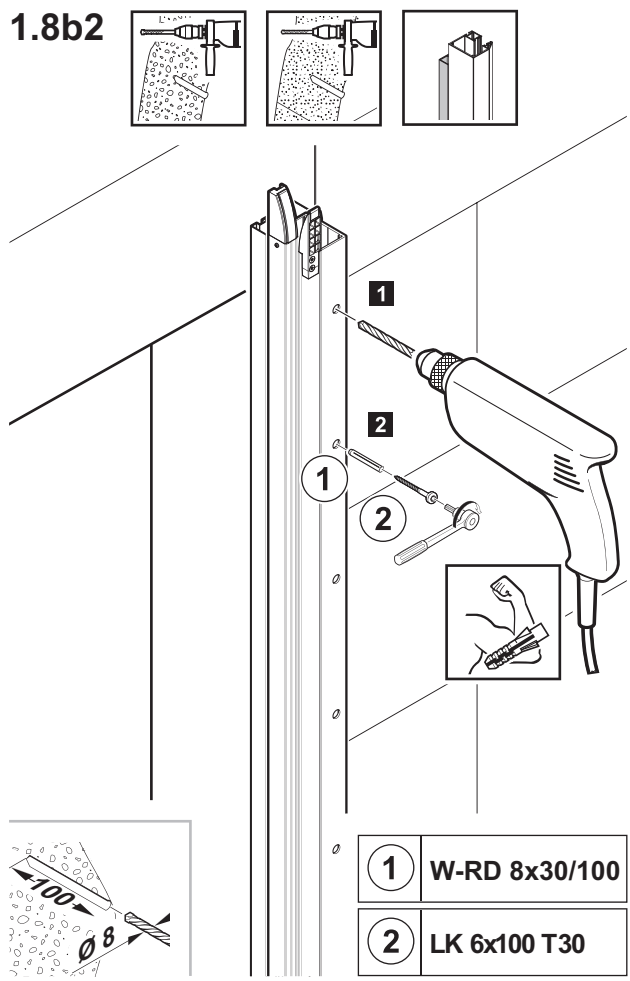
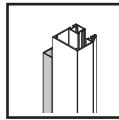
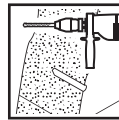
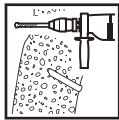

1 W-RD 8x30/100
2 LK 6x100 T30

1.8c2

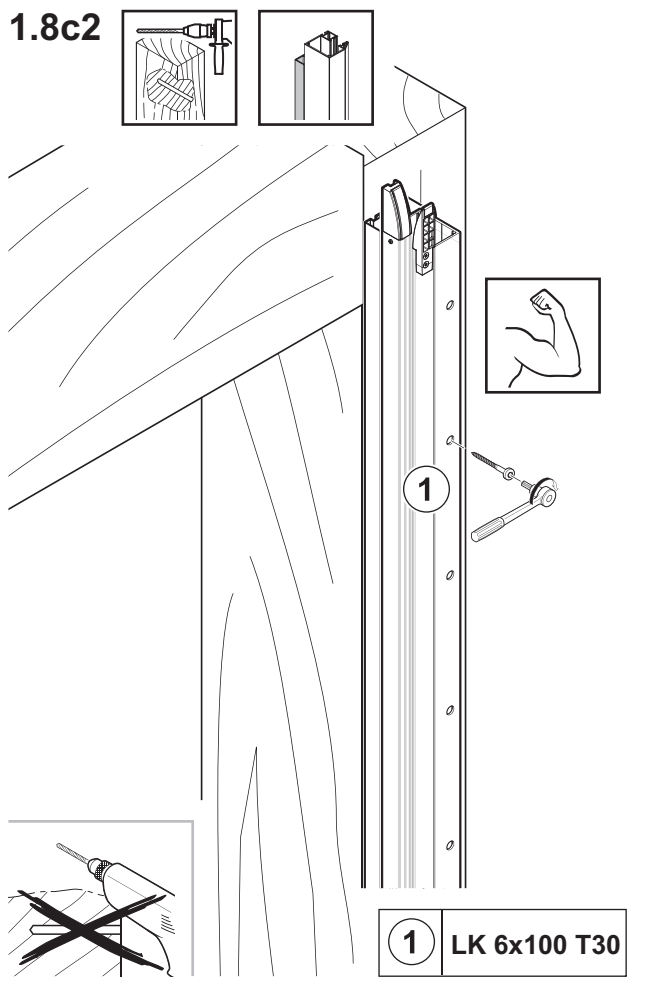
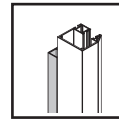
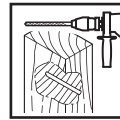

1 LK 6x100 T30

1.8a3

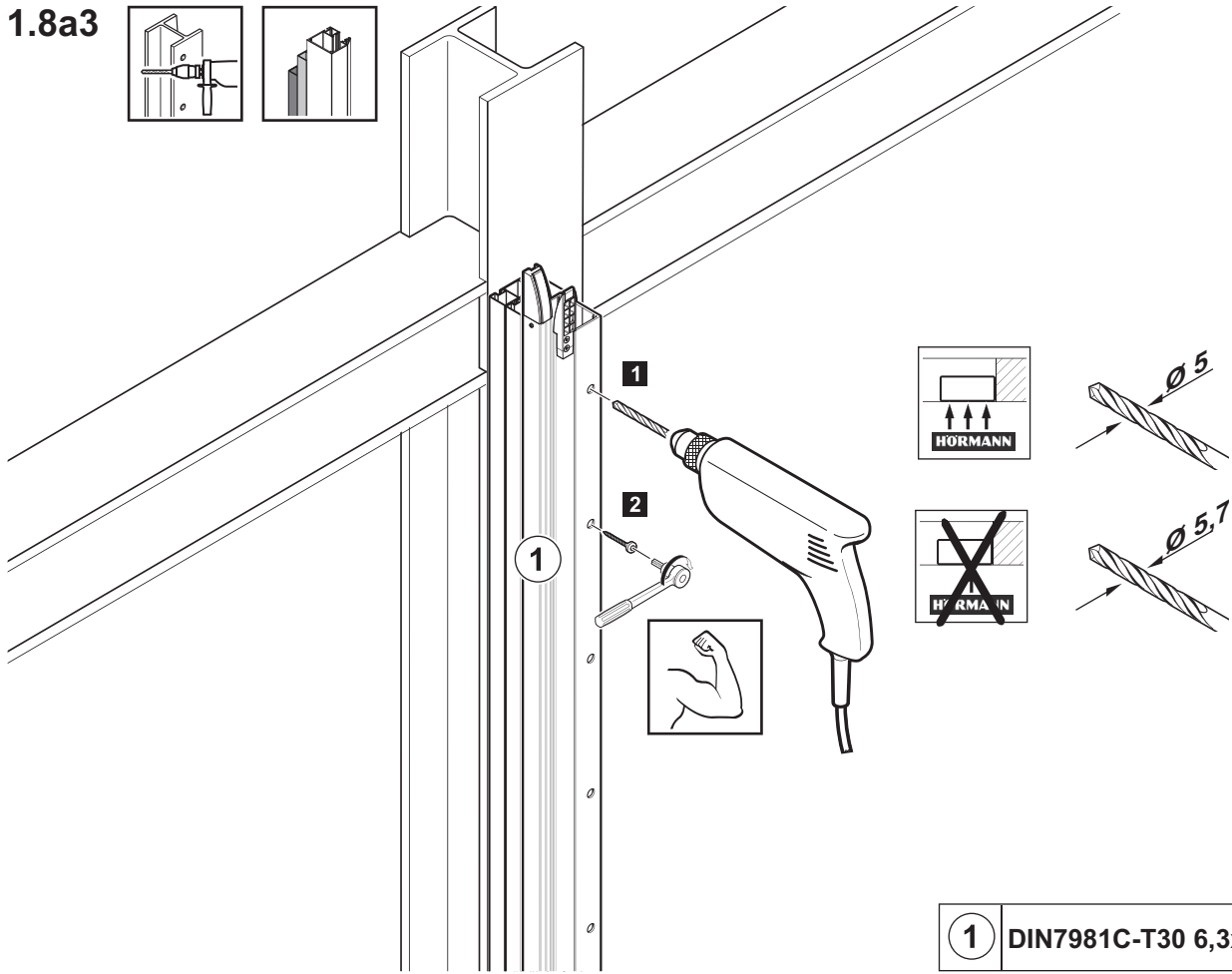
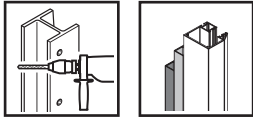

1 DIN7981C-T30 6,3x80

1.8b3

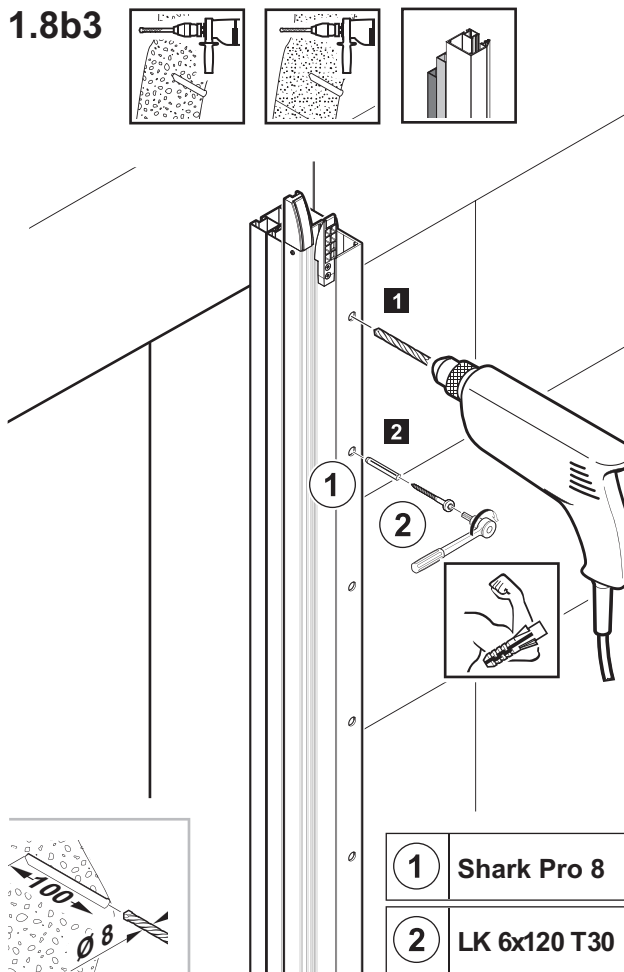

1 Shark Pro 8
2 LK 6x120 T30

1.8c3

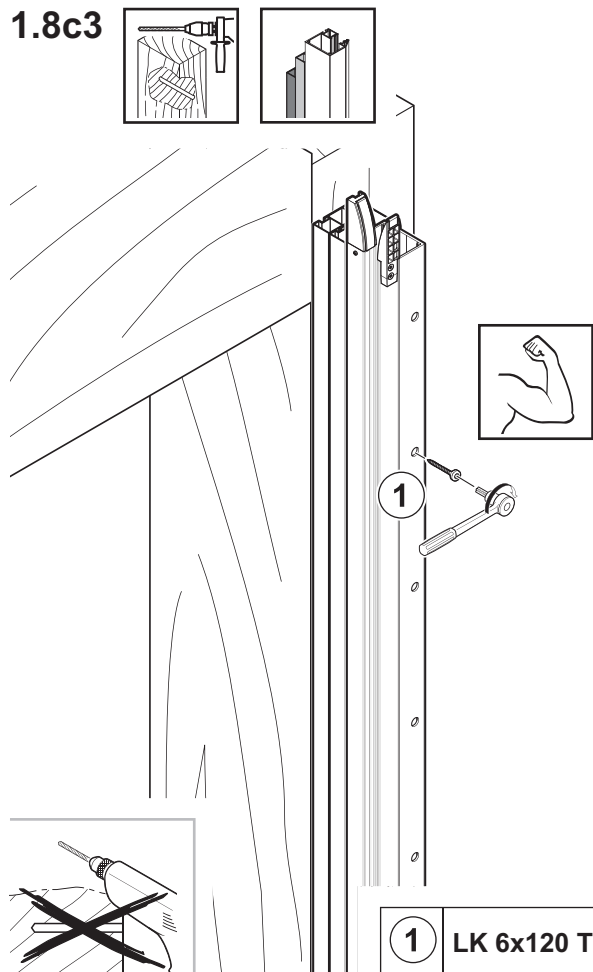
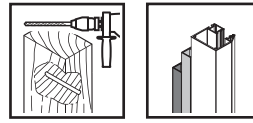

1 LK 6x120 T30

2

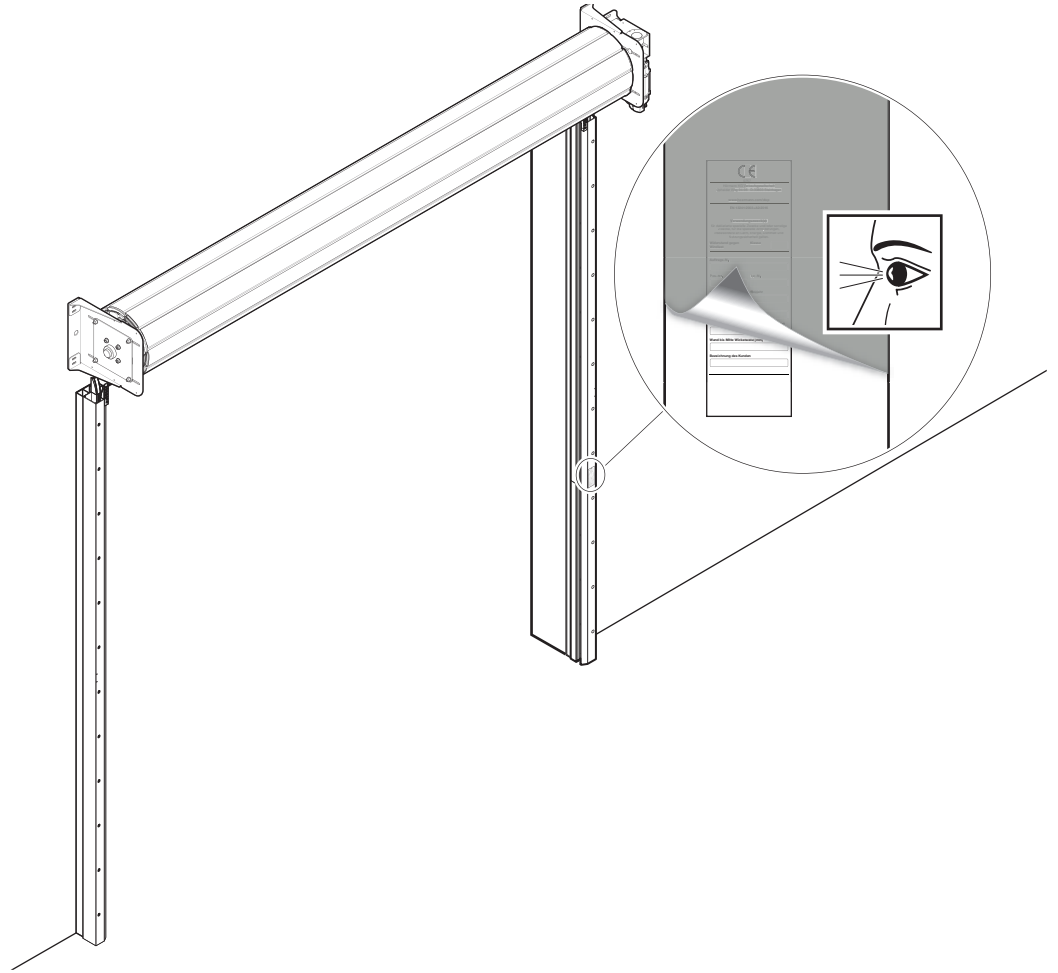

2.1

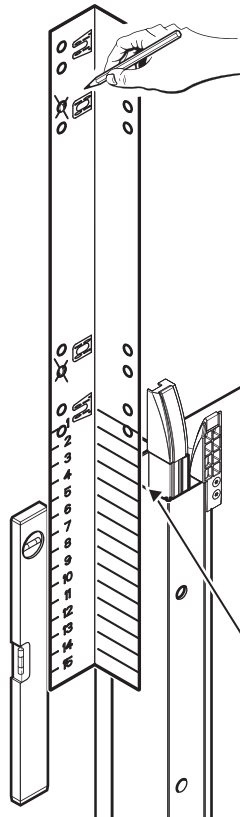
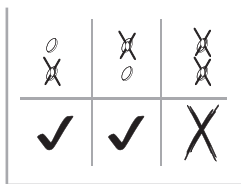
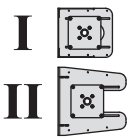

CE	
Hörmann KG Verkaufsgesellschaft Upheider Weg 94-98 33803 Steinhagen	
www.hoermann.com/dop EN 13041:2009+A2:2016	
Verwendungszweck(e): für deklarierte spezielle Zwecke und/oder sonstige Zwecke, für die spezielle Anforderungen insbesondere an Lärm, Energie, Dichtheit und Nutzungssicherheit gelten.	
Widerstand gegen Windlast	Klasse <input type="checkbox"/>
Wasserdichtheit	Klasse <input type="checkbox"/>
Wärmewiderstand W/(m ² K)	<input type="checkbox"/>
Luftdurchlässigkeit	Klasse <input type="checkbox"/>
Auftrags-Nr. <input type="text"/>	
Pos.-Nr. <input type="text"/>	Tor-Nr. <input type="text"/>
Tortyp <input type="text"/>	Baujahr <input type="text"/>
Behang <input type="text"/>	
Größe [mm]	Gewicht [kg]
Anchorenposition: <input checked="" type="checkbox"/>	
Sturz bis Mitte Wickelwelle [mm] <input type="text"/>	
Bezeichnung des Kunden <input type="text"/>	

2.2a

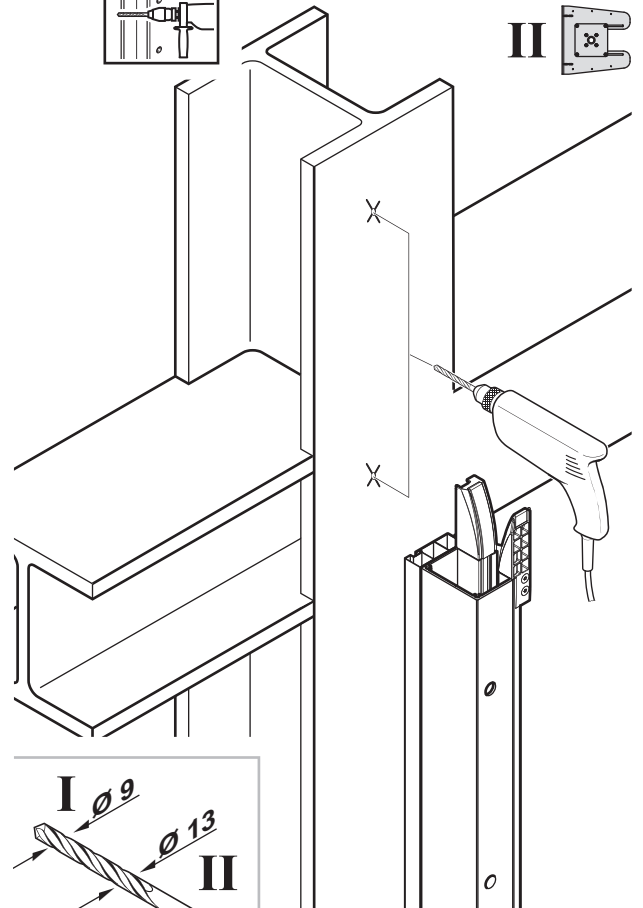
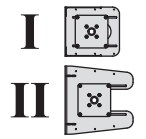
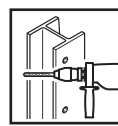

2.2b1

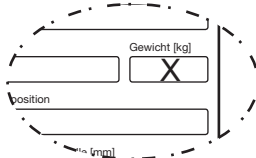
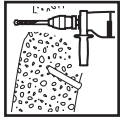

$X \leq 350 \text{ kg} = A$
 $X > 350 \text{ kg} = B$

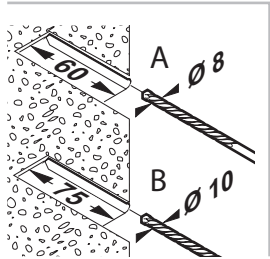
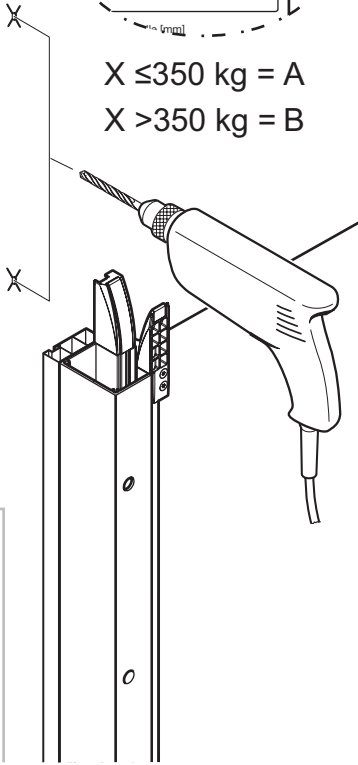

2.2b2

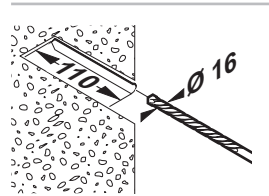
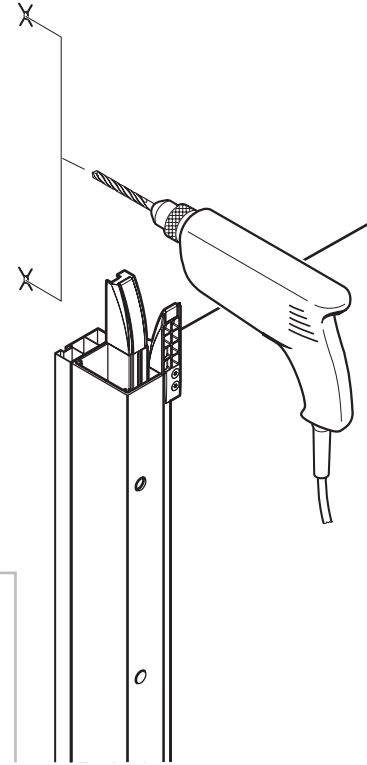
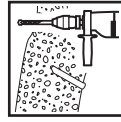

2.2c

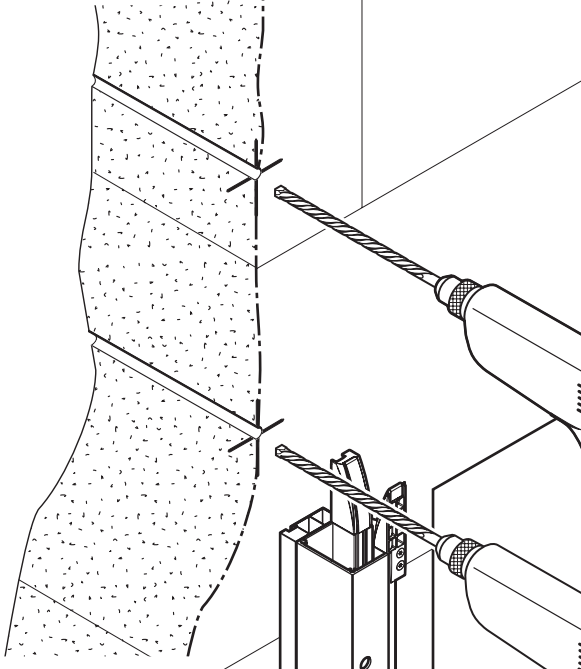
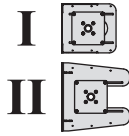

2.2d

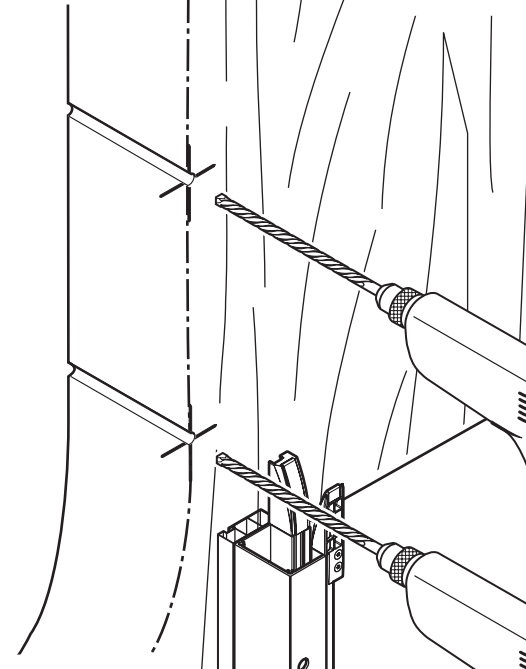
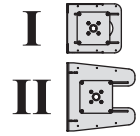

3

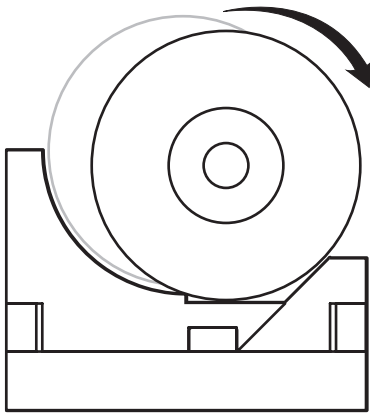
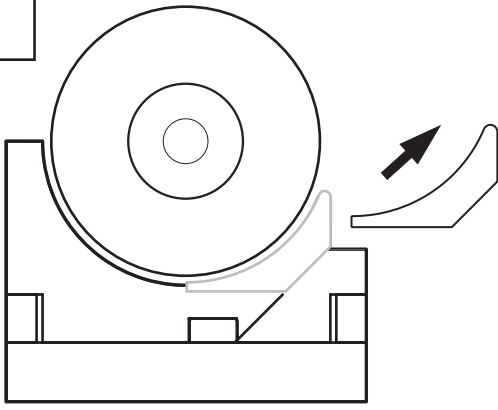

3.1

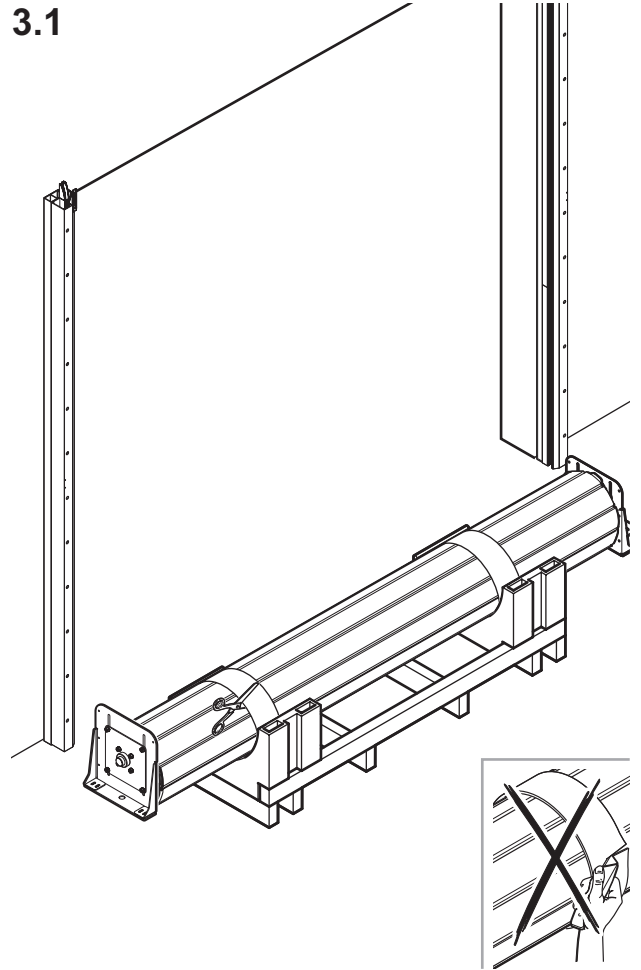

3.2

A

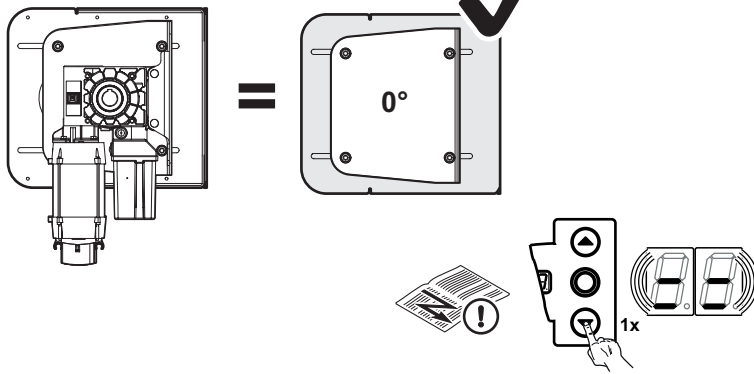

B

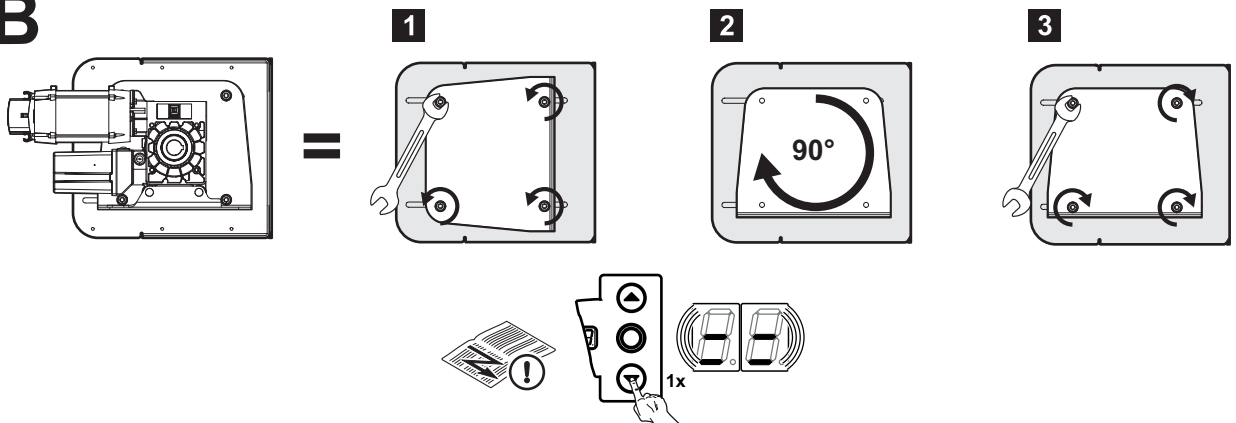

3.3

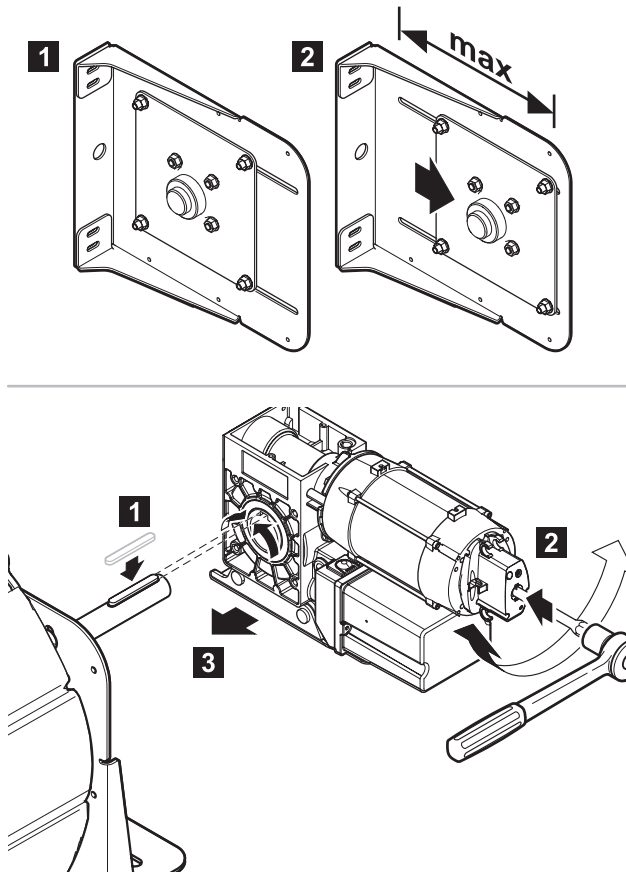

3.4

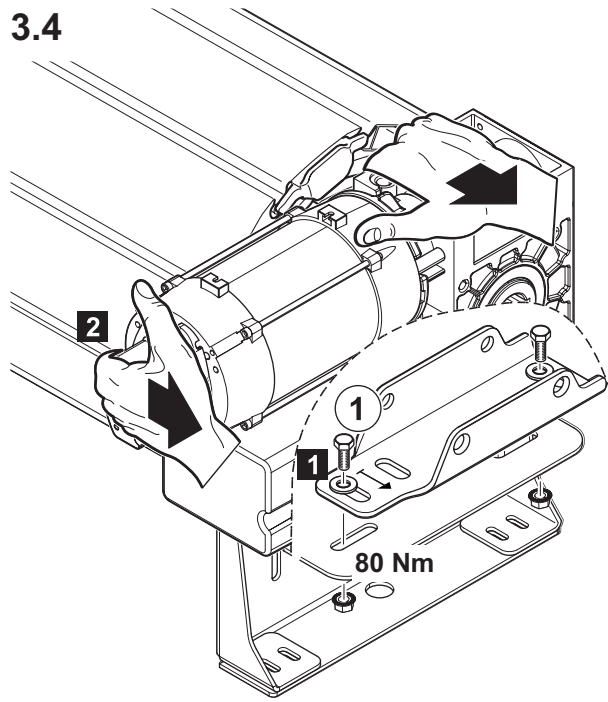

	①
40	DIN 933 M12x35 8.8 A2B
60	DIN 933 M16x35 8.8 A2B

3.5

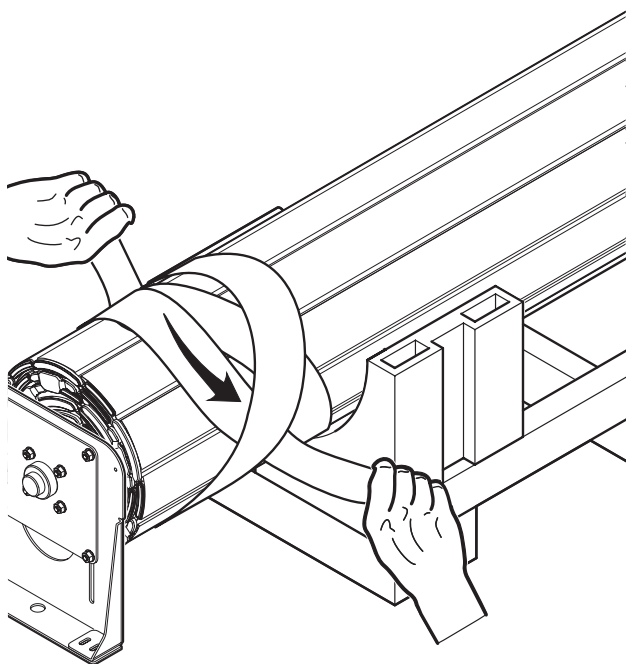

3.6

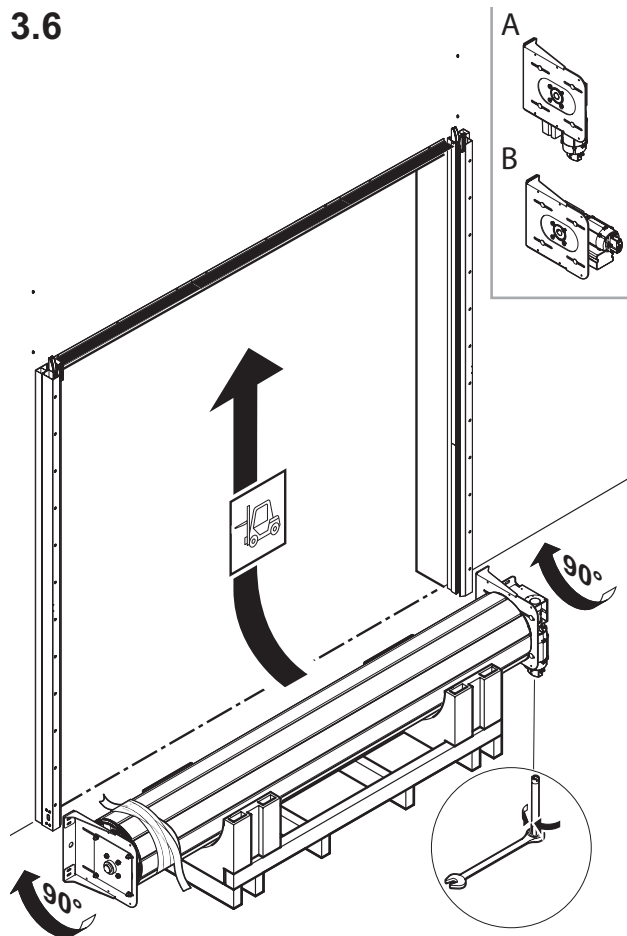

3.7a I

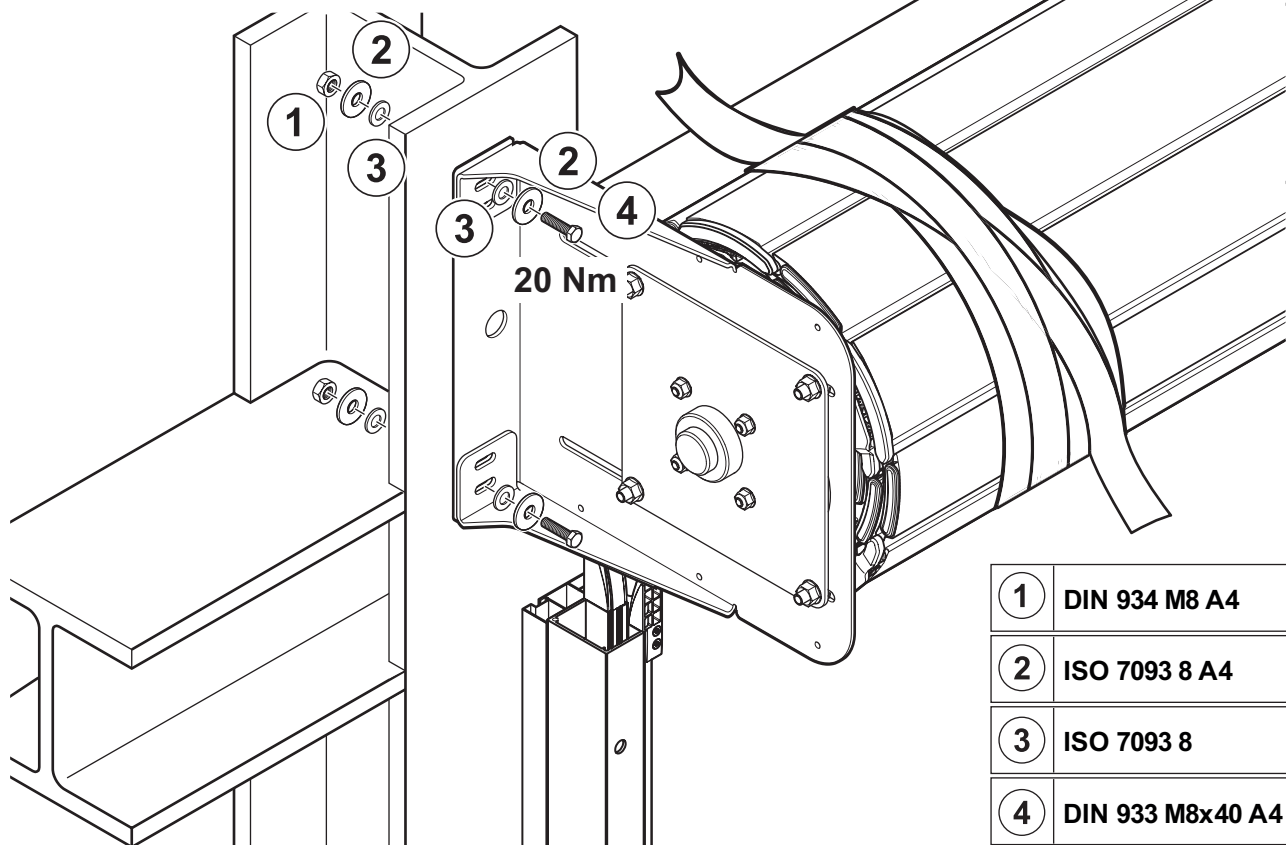
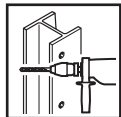

1	DIN 934 M8 A4
2	ISO 7093 8 A4
3	ISO 7093 8
4	DIN 933 M8x40 A4

3.7a II

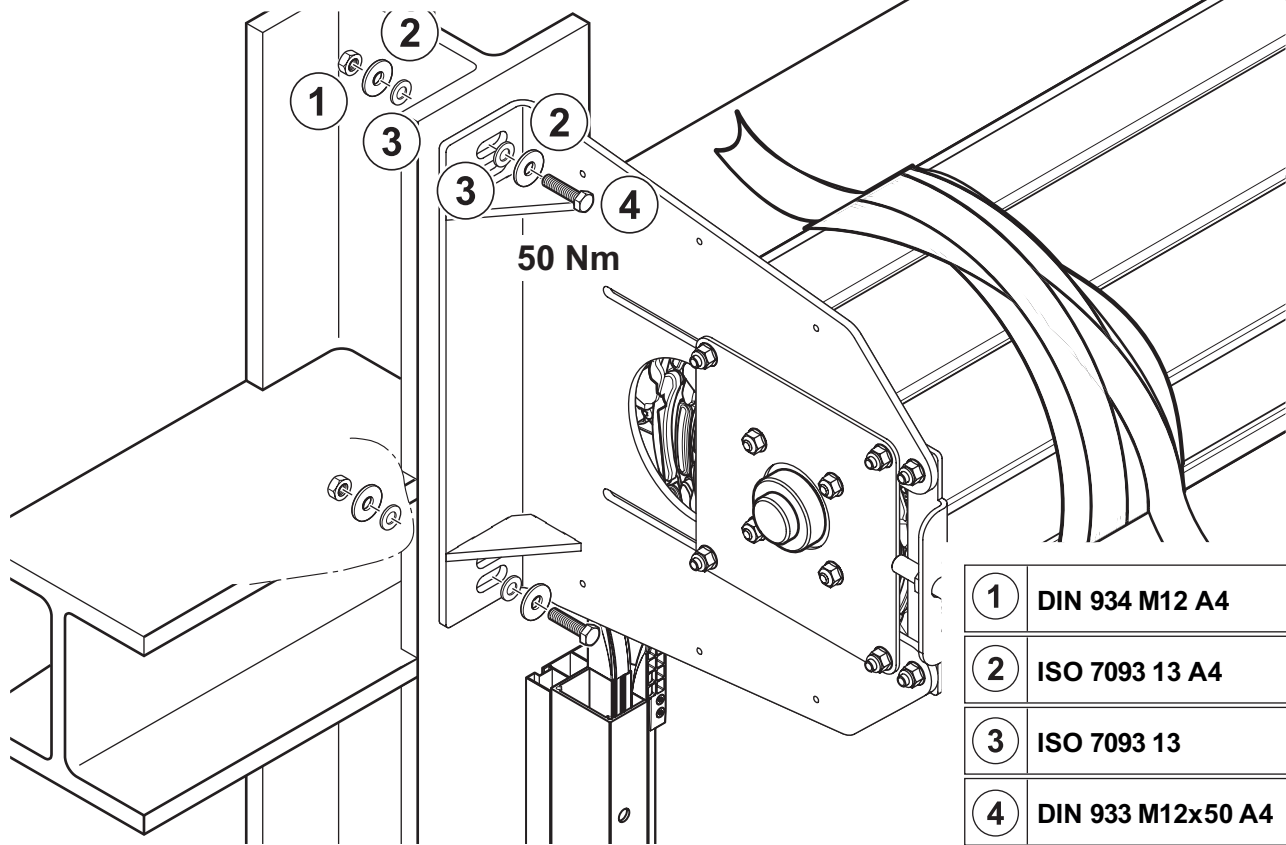
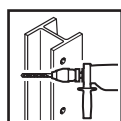

1	DIN 934 M12 A4
2	ISO 7093 13 A4
3	ISO 7093 13
4	DIN 933 M12x50 A4

3.7b I



I A 20 Nm
I B 35 Nm

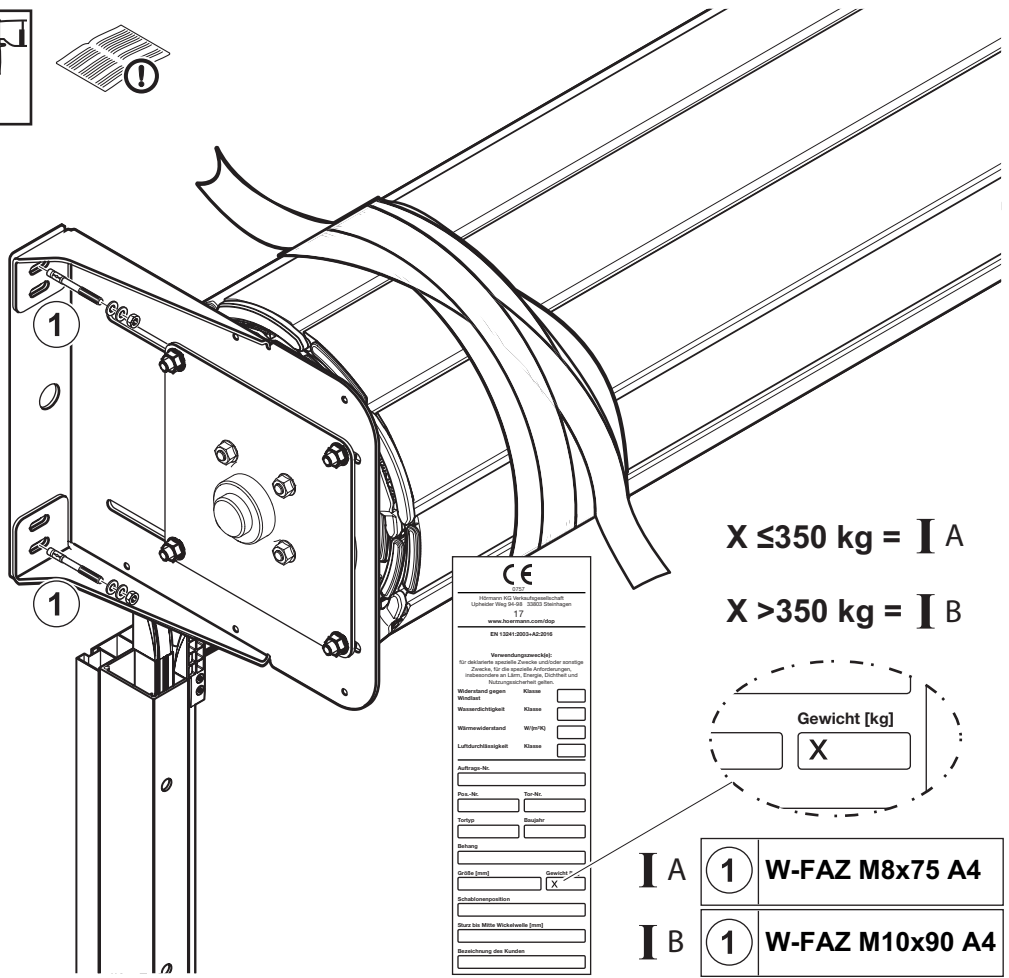

$X \leq 350 \text{ kg} = \text{I A}$

$X > 350 \text{ kg} = \text{I B}$

Gewicht [kg]	
	X

CE	
<small>Hörmann KG Unternehmensbereich Lipziger Str. 54-58 33023 Steinhagen 17 www.hoermann.com/de</small>	
<small>EN 12412:2004+A2:2016</small>	
<small>Verwendungszweck: Für die folgenden speziellen Zwecke sind die vorliegende Zurteile, für die spezielle Anforderungen, insbesondere im Hinblick auf die Sicherheit und Korrosionsbeständigkeit gelten.</small>	
Widerstand gegen	Klasse <input type="checkbox"/>
Witterung	Klasse <input type="checkbox"/>
Witterungsbestand	Wsp./% <input type="checkbox"/>
Luftverschmutzung	Klasse <input type="checkbox"/>
Auftrags-Nr. <input type="text"/>	
Proj.-Nr.	Teil-Nr.
Stufe	Stadium
Belastung <input type="checkbox"/>	
Ordn.-Zahl	Gezeichnet <input checked="" type="checkbox"/>
Schaltplanposition <input type="text"/>	
Stanz- bis Mitte-Winkelstelle (mm) <input type="text"/>	
Bezeichnung des Kunden <input type="text"/>	

- I A** ① **W-FAZ M8x75 A4**
- I B** ① **W-FAZ M10x90 A4**

3.7b II

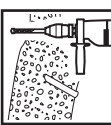

110 Nm

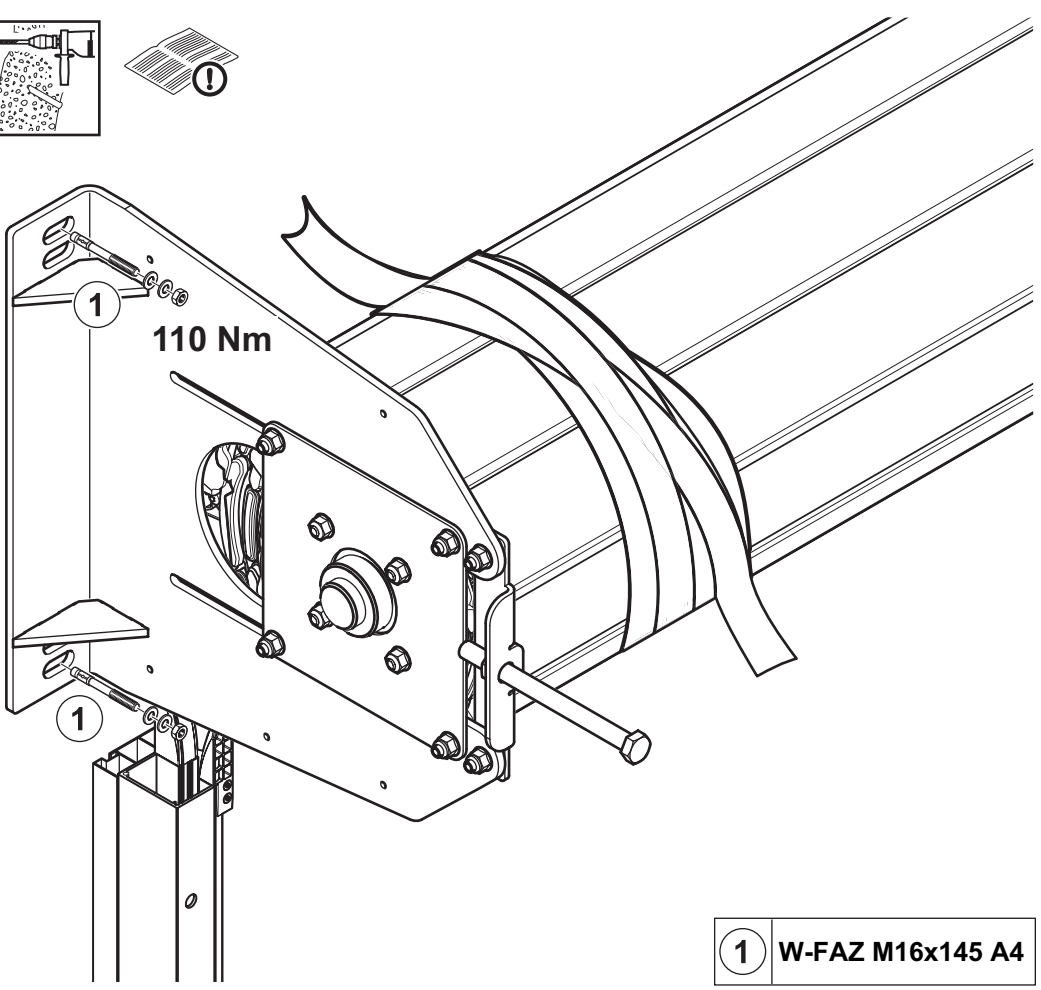

- ① **W-FAZ M16x145 A4**

3.7c I

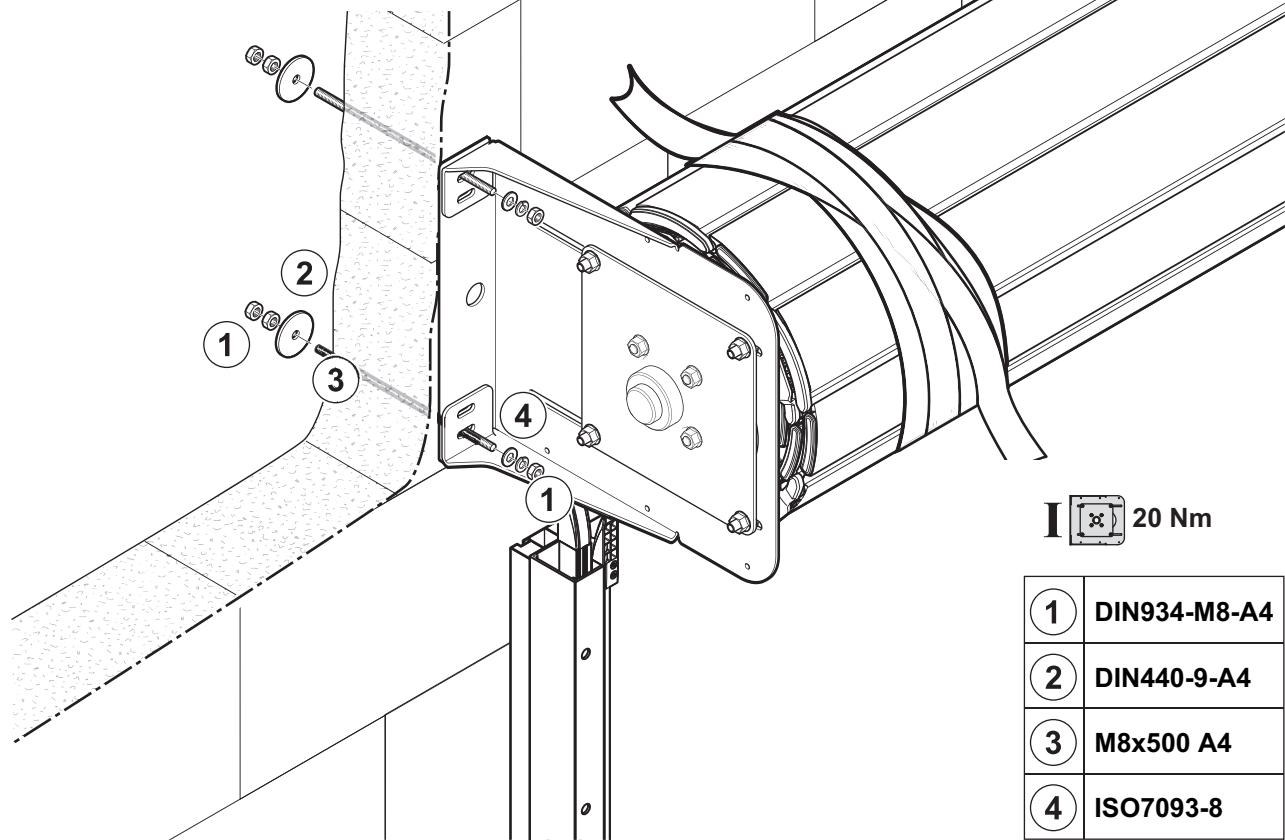

I  20 Nm

1	DIN934-M8-A4
2	DIN440-9-A4
3	M8x500 A4
4	ISO7093-8

3.7c II

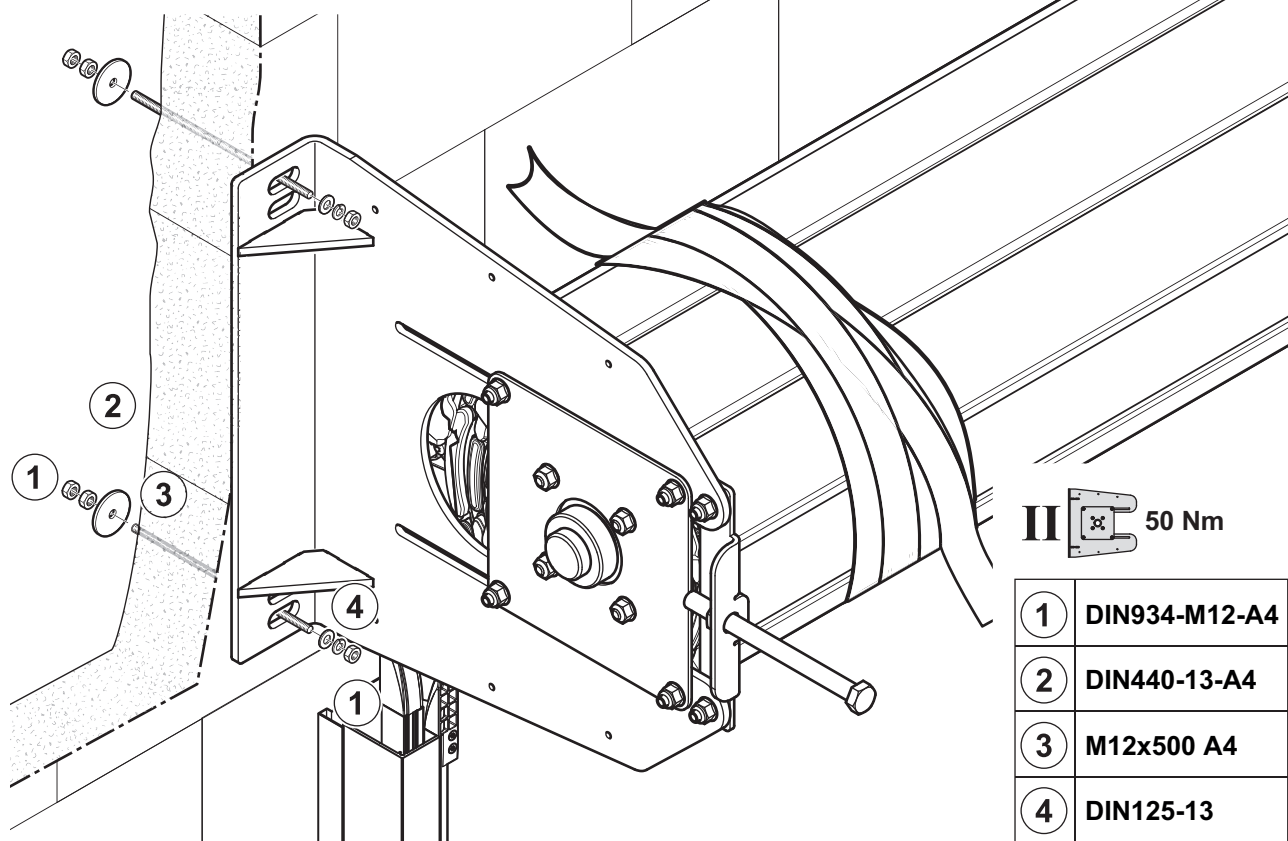
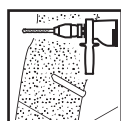

II  50 Nm

1	DIN934-M12-A4
2	DIN440-13-A4
3	M12x500 A4
4	DIN125-13

3.7d I

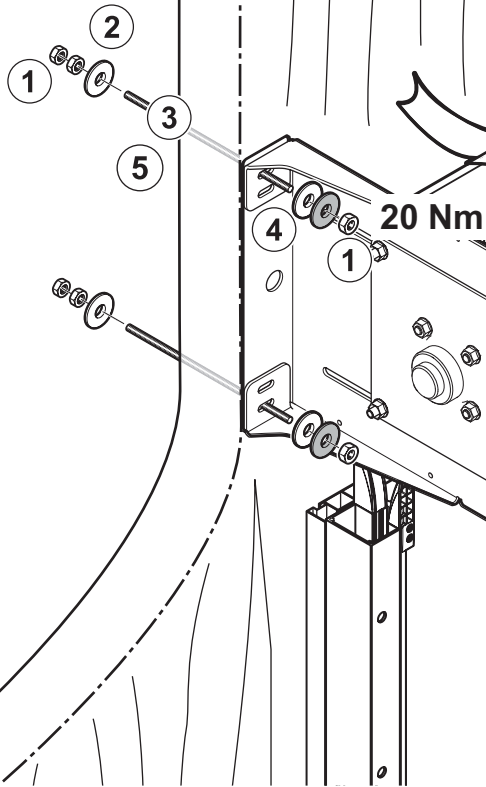

1	DIN 934 M8 A4
2	DIN 440-9-A4
3	M8x500 A4
4	ISO 7093-8
5	ISO 7093-8-A4

3.7d II

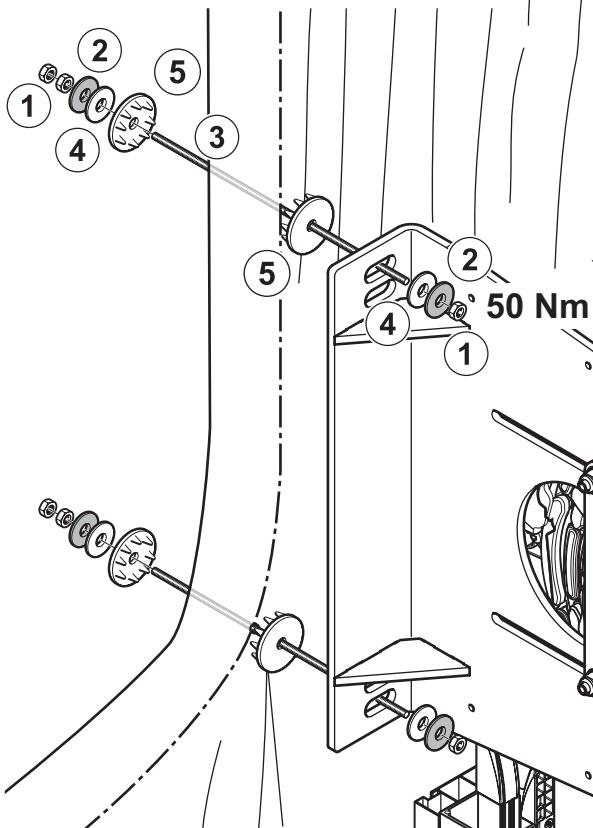

1	DIN 934 M12 A4
2	ISO 7093-13-A4
3	M12x500 A4
4	ISO 7093-13
5	TYP D-TE50-M12

3.8

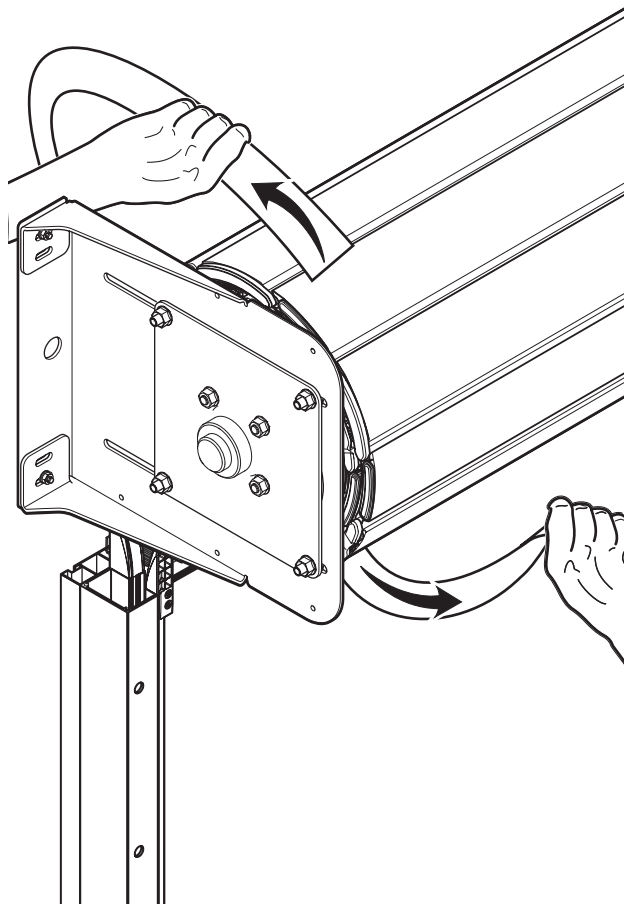

3.9

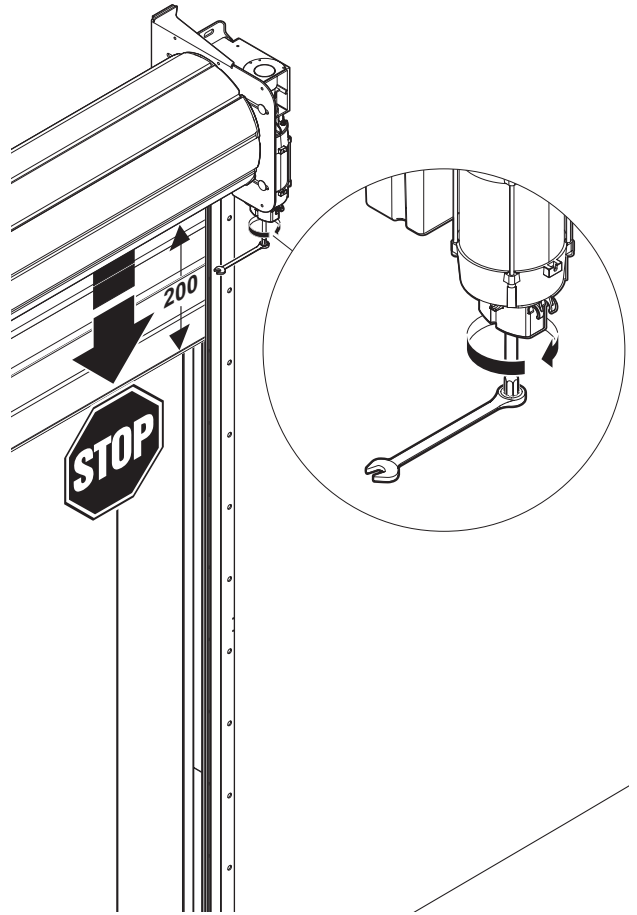

3.10

CE	
0757	
Hörmann KG Verkaufsgesellschaft Upheder Weg 94-98 33803 Steinhagen	
www.hoermann.com/dop	
EN 13241:2003+A2:2016	
Verwendungszweck(e): für deklarierte spezielle Zwecke und/oder sonstige Zwecke, für die spezielle Anforderungen, insbesondere an Lärm, Energie, Dichtigkeit und Nutzungssicherheit gelten.	
Widerstand gegen Windlast	Klasse <input type="checkbox"/>
Wasserdichtigkeit	Klasse <input type="checkbox"/>
Wärmeisolation	W/(m ² K) <input type="checkbox"/>
Luftdurchlässigkeit	Klasse <input type="checkbox"/>
Auftrags-Nr. <input type="text"/>	
Pos.-Nr.	Tor-Nr. <input type="text"/>
Tortyp	Baujahr <input type="text"/>
Behang <input checked="" type="checkbox"/>	
Größe [mm]	Gewicht [kg]
Schablonenposition <input type="text"/>	
Sturz bis Mitte Wickelwelle [mm] <input type="text"/>	
Bezeichnung des Kunden <input type="text"/>	

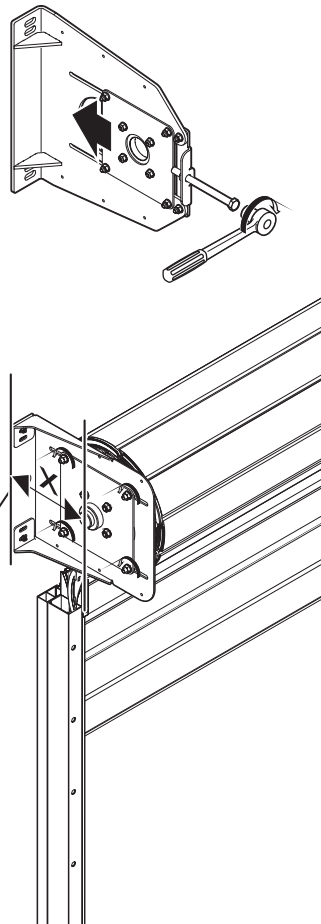

3.11

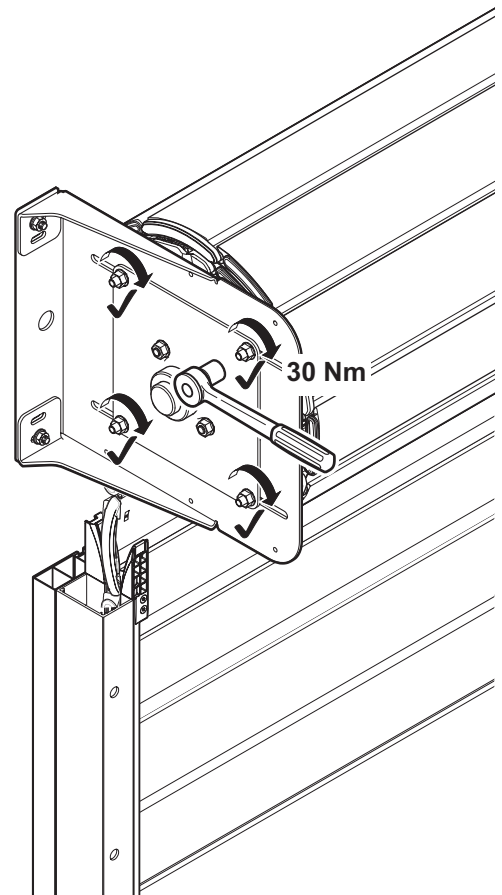

4

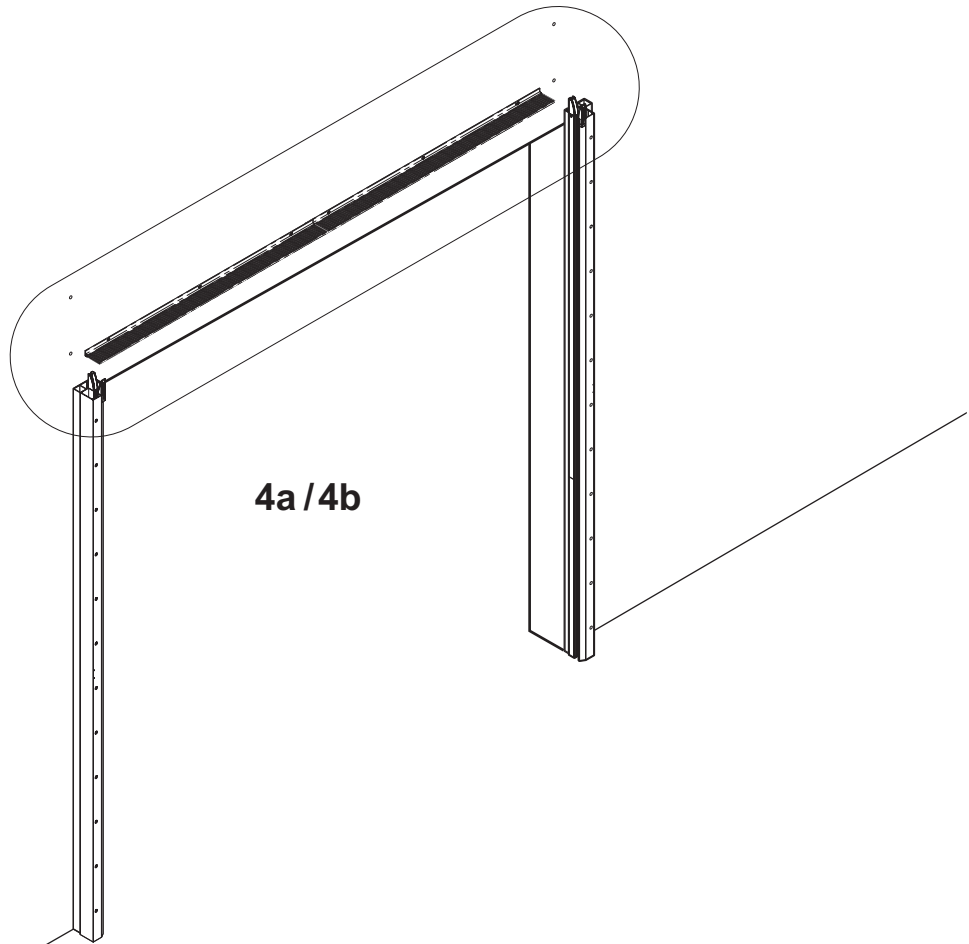

4a/4b

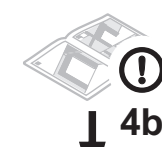
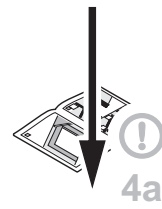
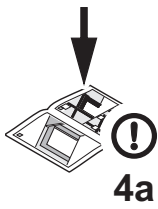
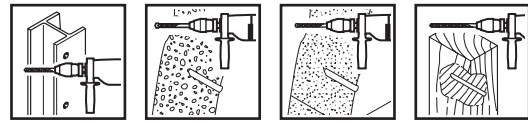
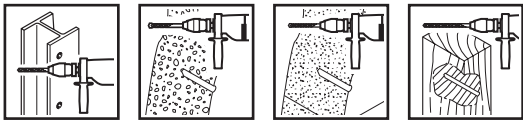
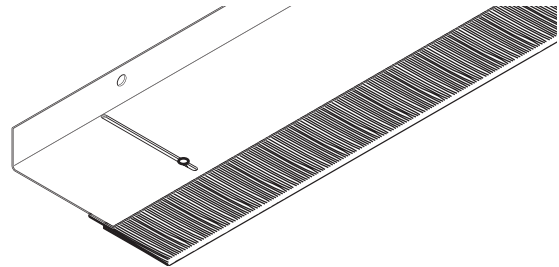
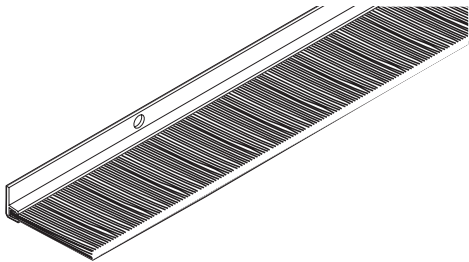

4a

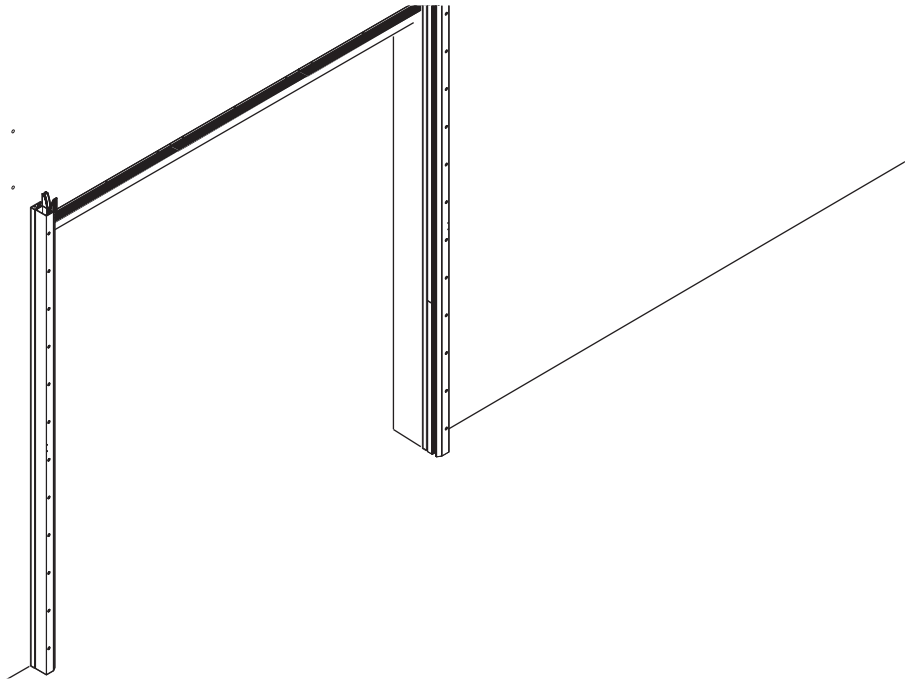

4a.1

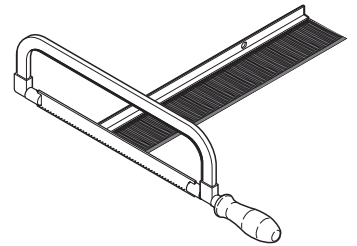
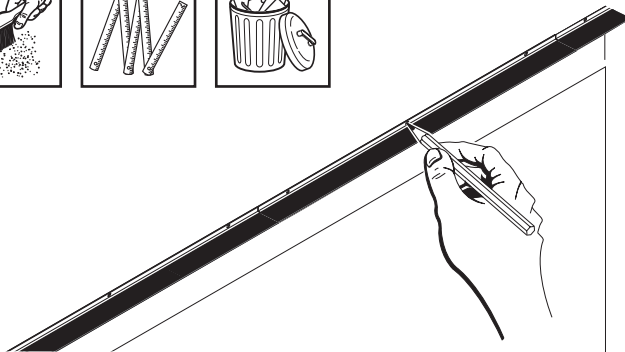

4a.2

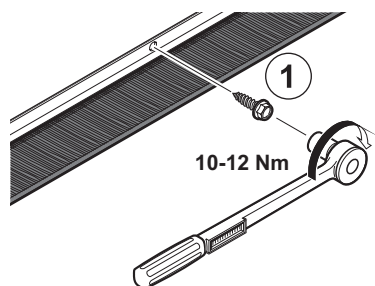
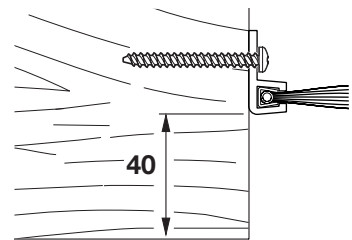
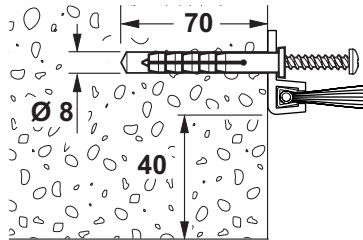
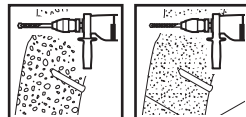
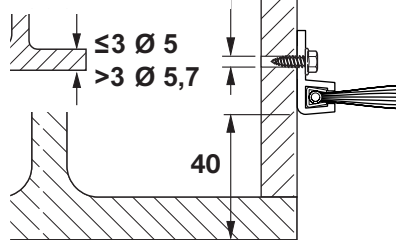
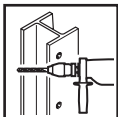

1 DIN7981C-T30 6,3x19

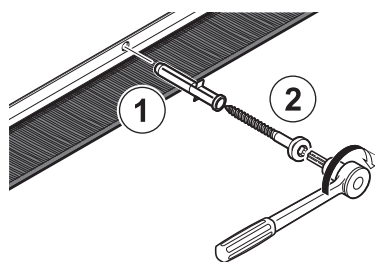

1 KST 8x46
2 LK6x60 T30

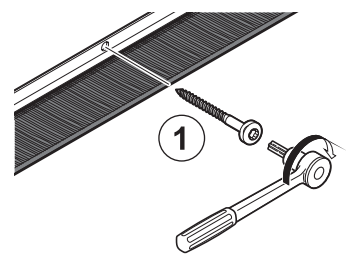

1 LK6x60 T30

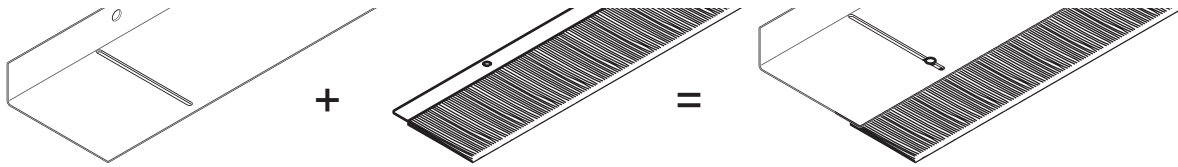

4b.1

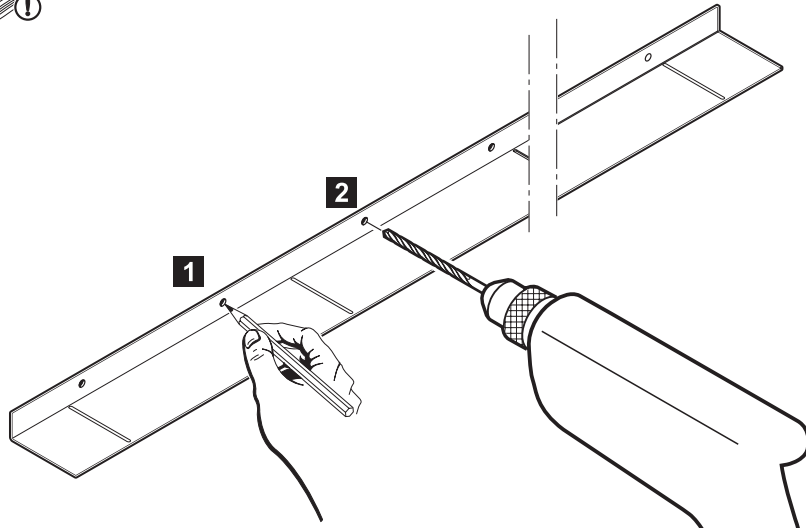

4b.2

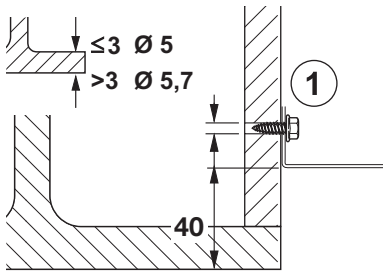
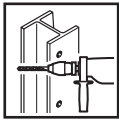

1 DIN7981C-T30 6,3x19

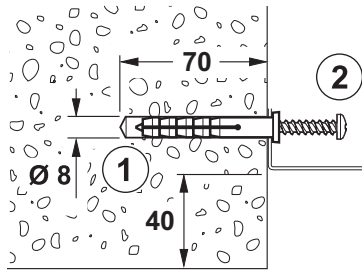
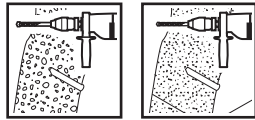

1 KST 8x46
2 LK6x60 T30

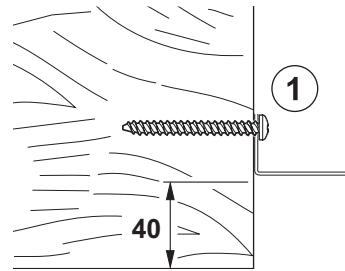
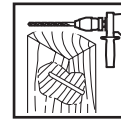

1 LK6x60 T30

4b.3

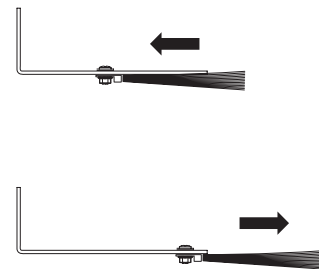
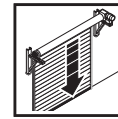
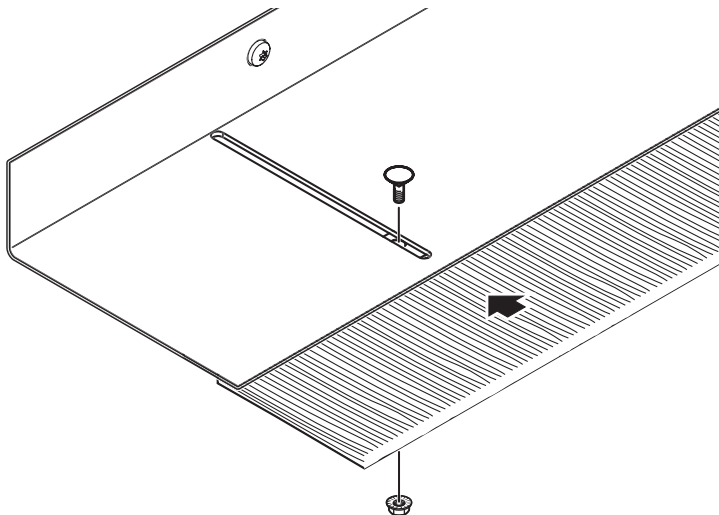

5

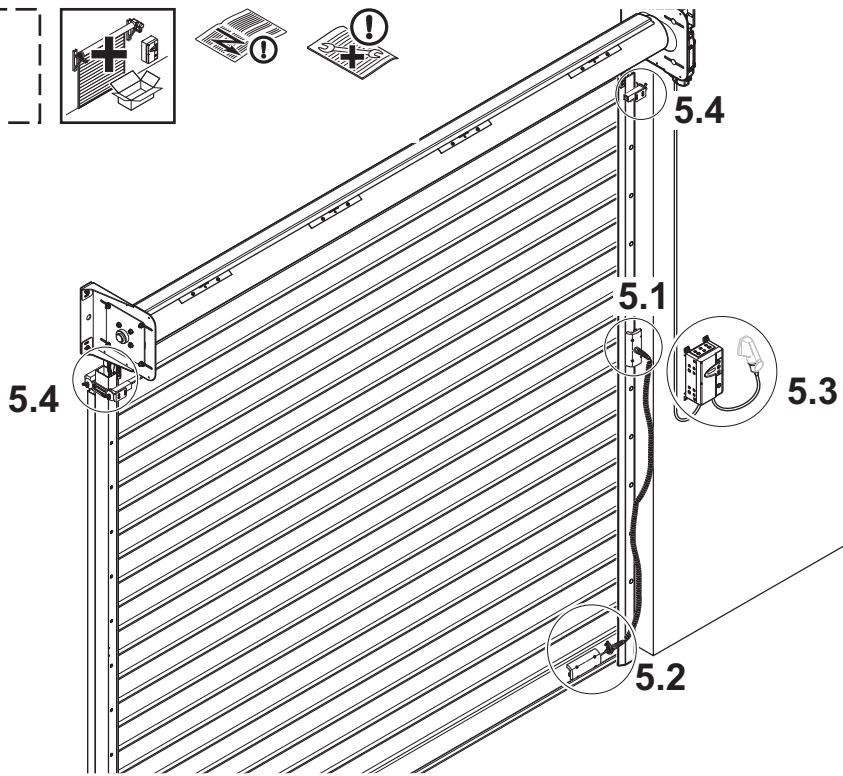

5.1

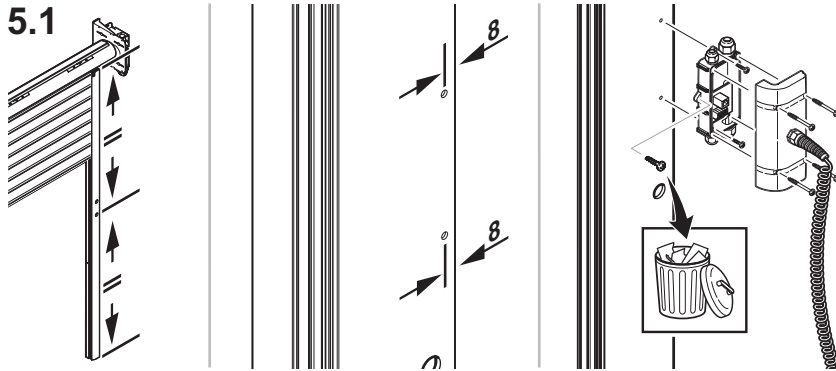

5.3

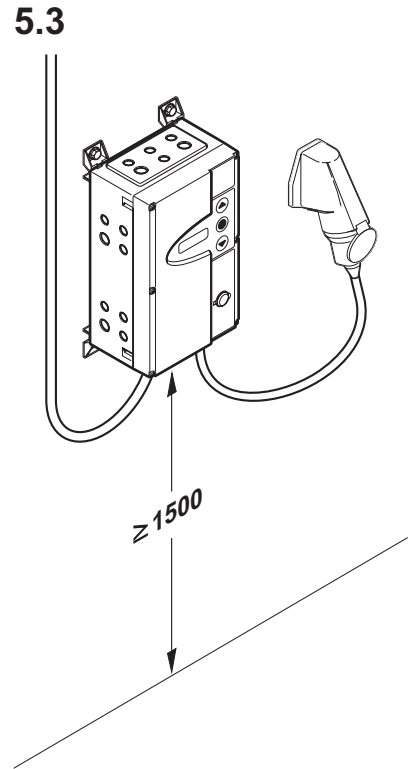

5.2

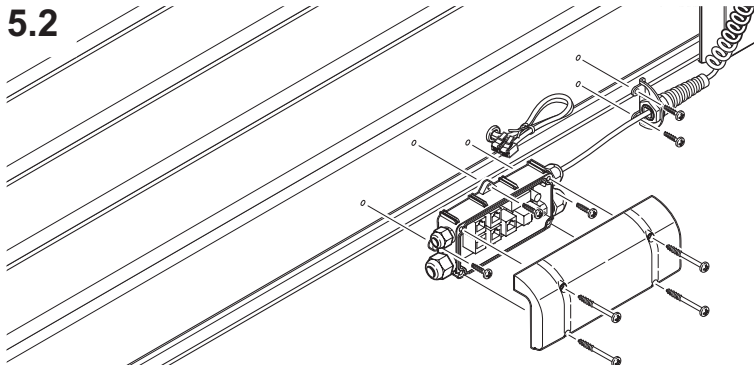

5.4

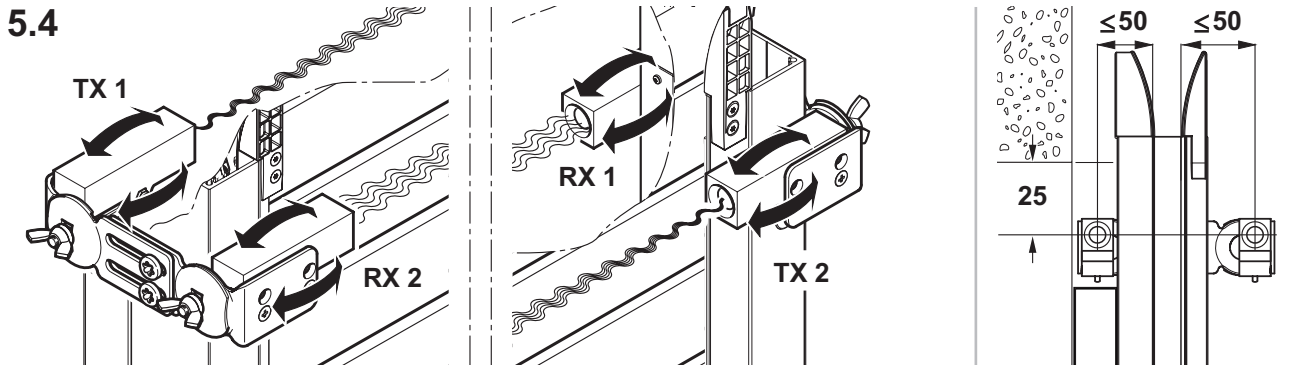

5.5

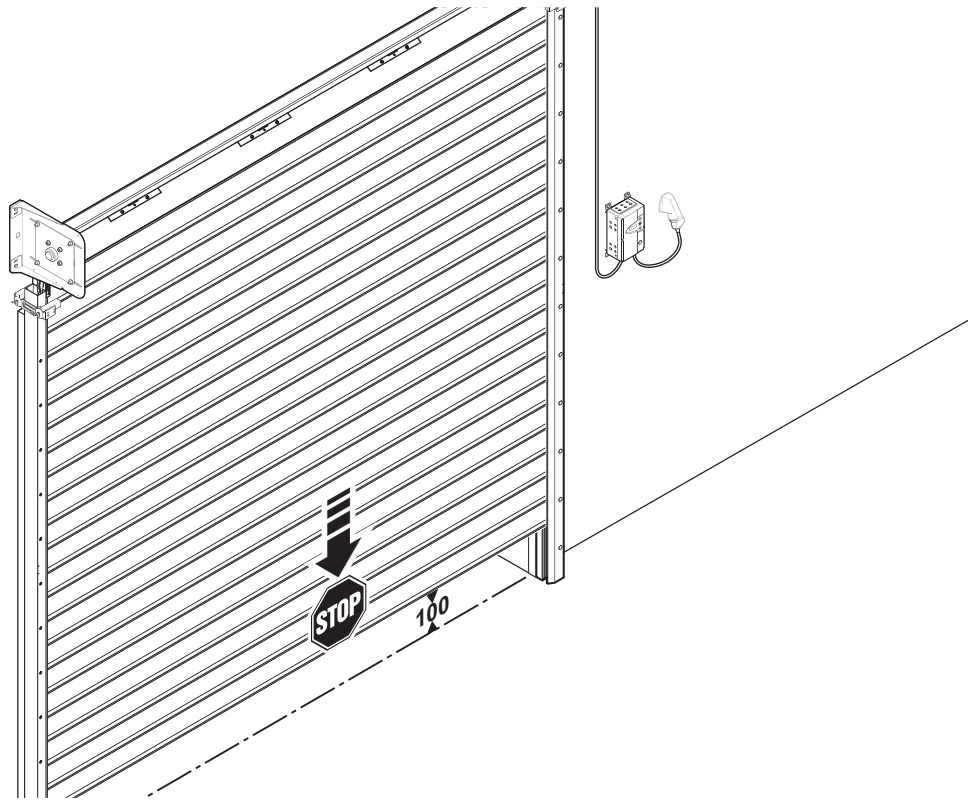

5.6

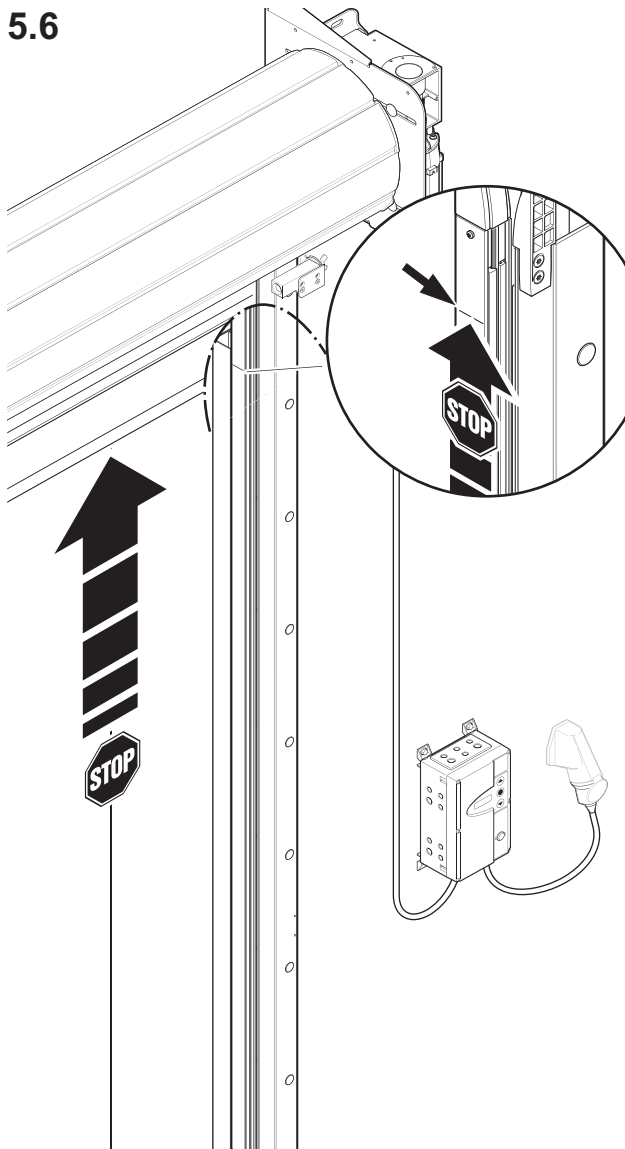

5.7

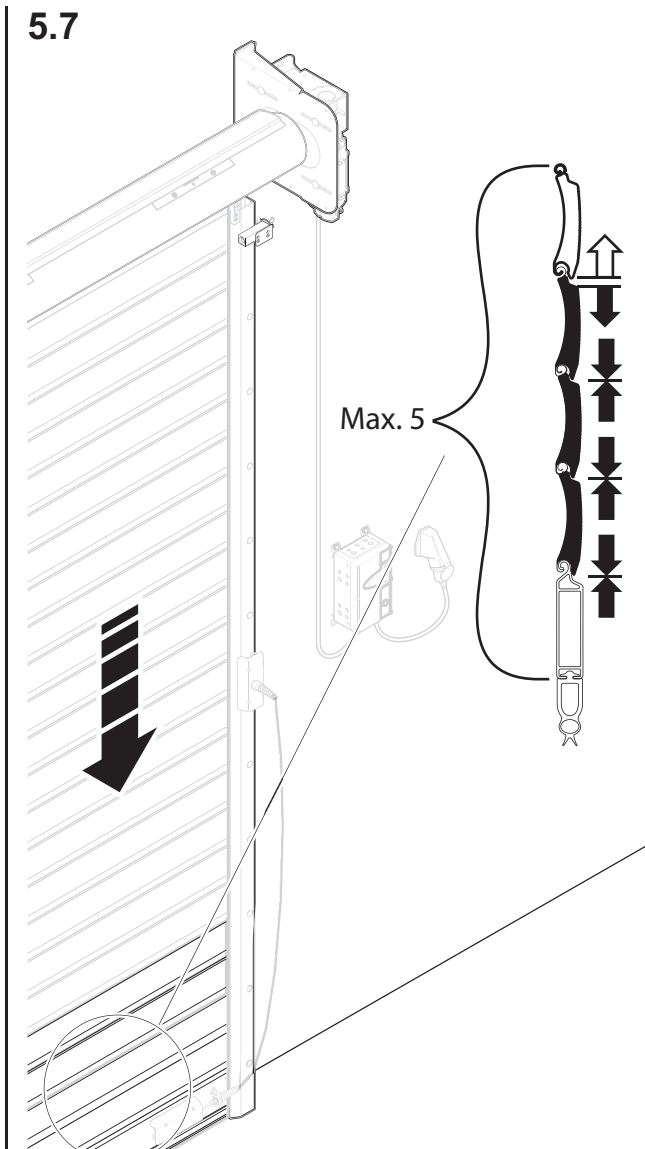

6a

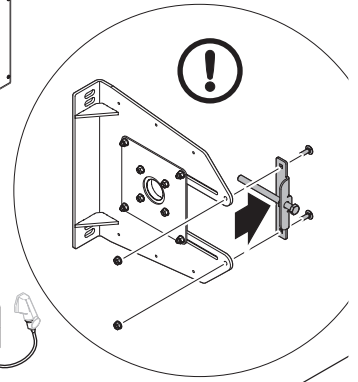
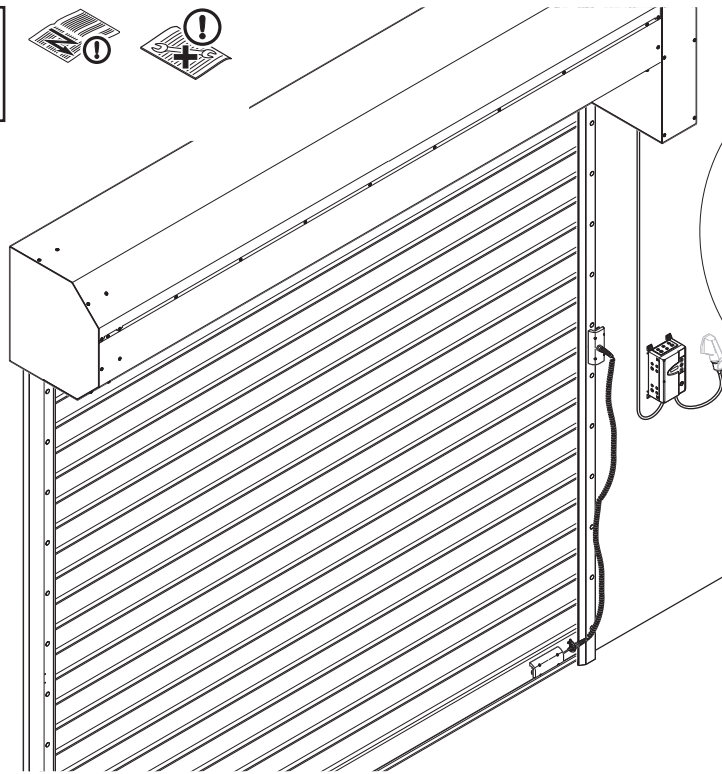

6a.1

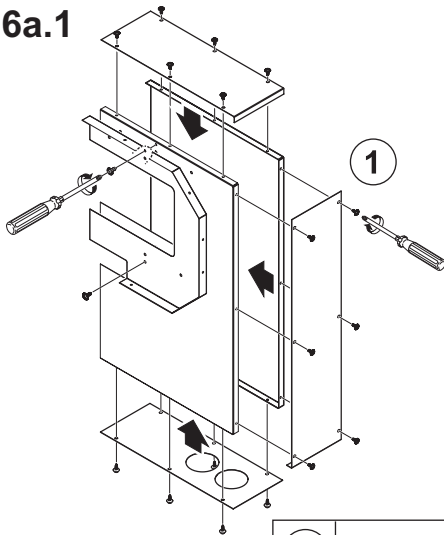

1 DIN7981C-T30 6,3x19

6a.2

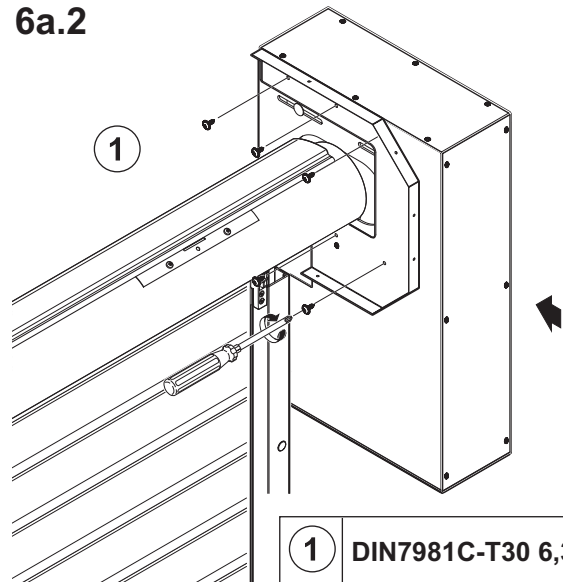

1 DIN7981C-T30 6,3x19

6a.3

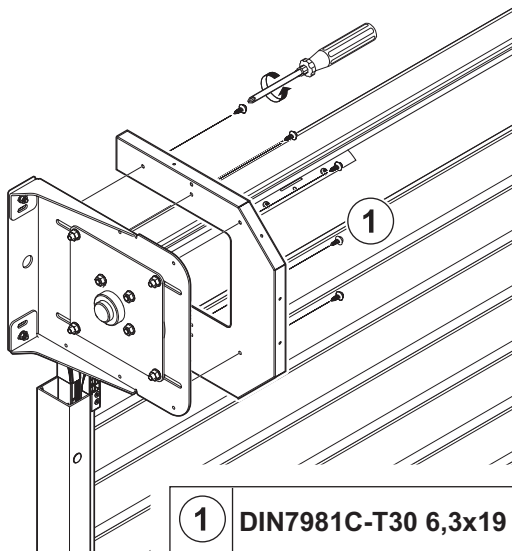

1 DIN7981C-T30 6,3x19

6a.4

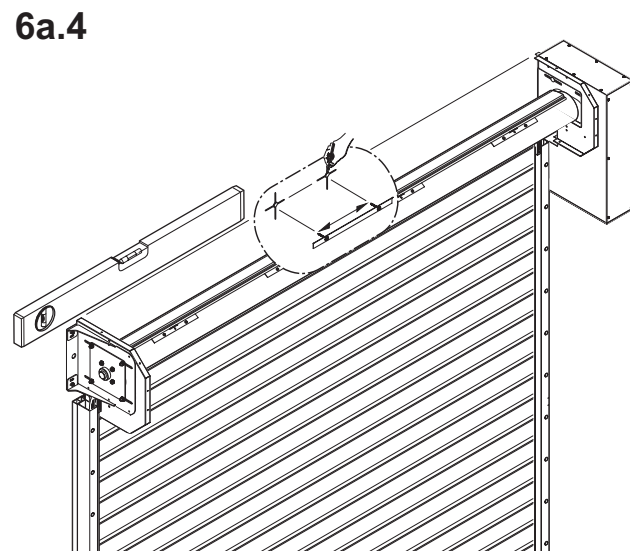

6a.5

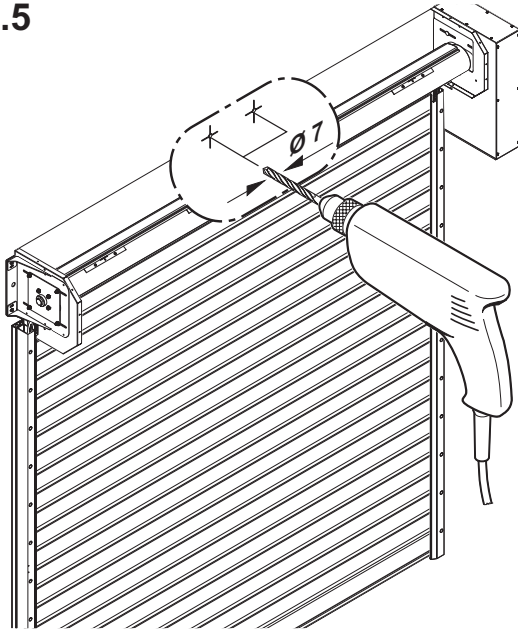

6a.6

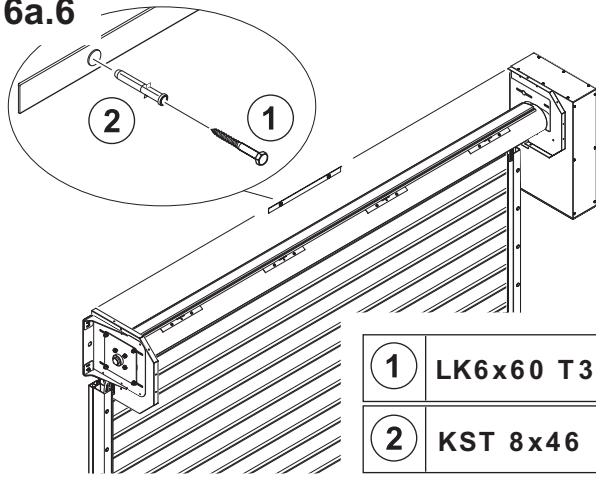

- | | |
|---|------------|
| 1 | LK6x60 T30 |
| 2 | KST 8x46 |

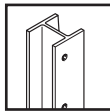

- | | |
|---|---------------------|
| 1 | DIN7981C-T30 6,3x15 |
|---|---------------------|

6a.7

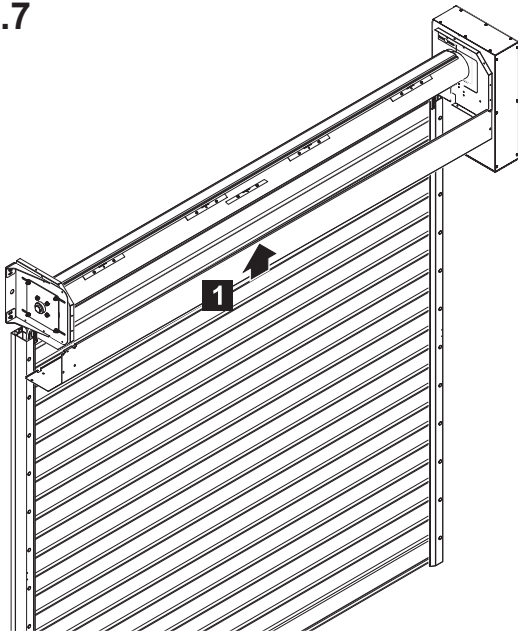

6a.8

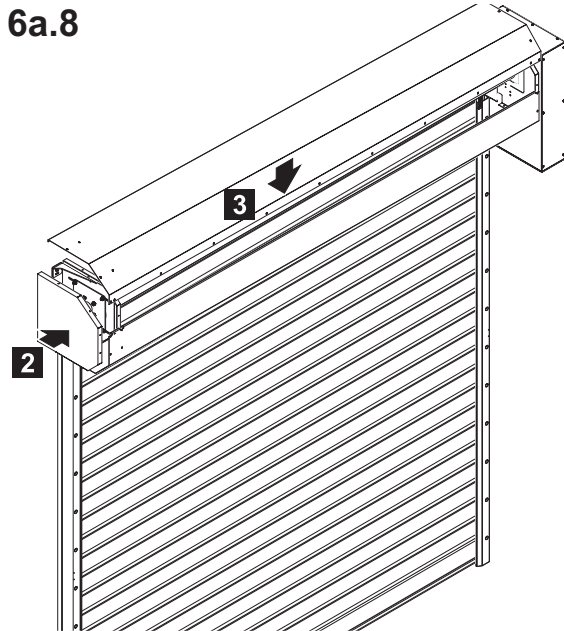

6a.9

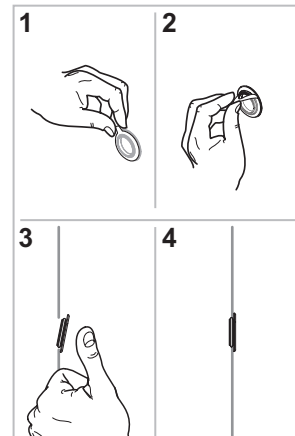
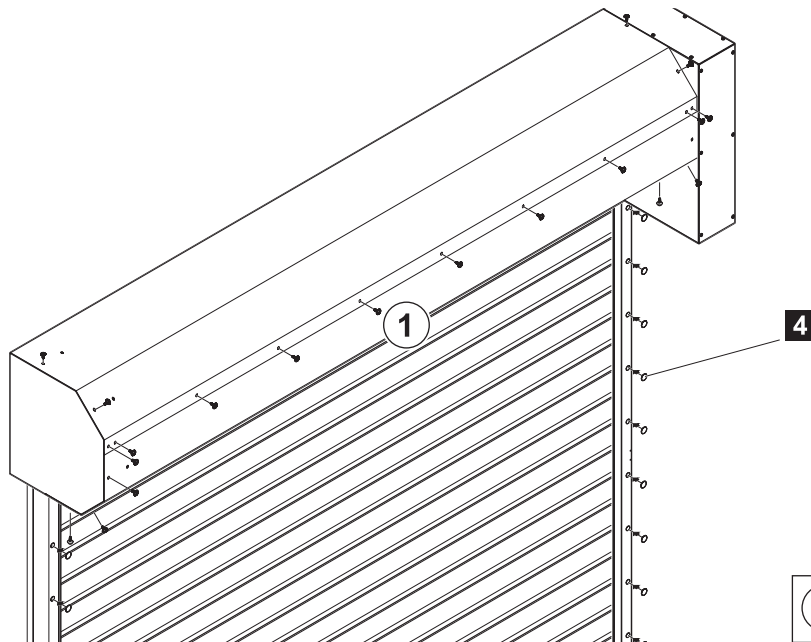

- | | |
|---|---------------------|
| 1 | DIN7981C-T30 6,3x19 |
|---|---------------------|

6b

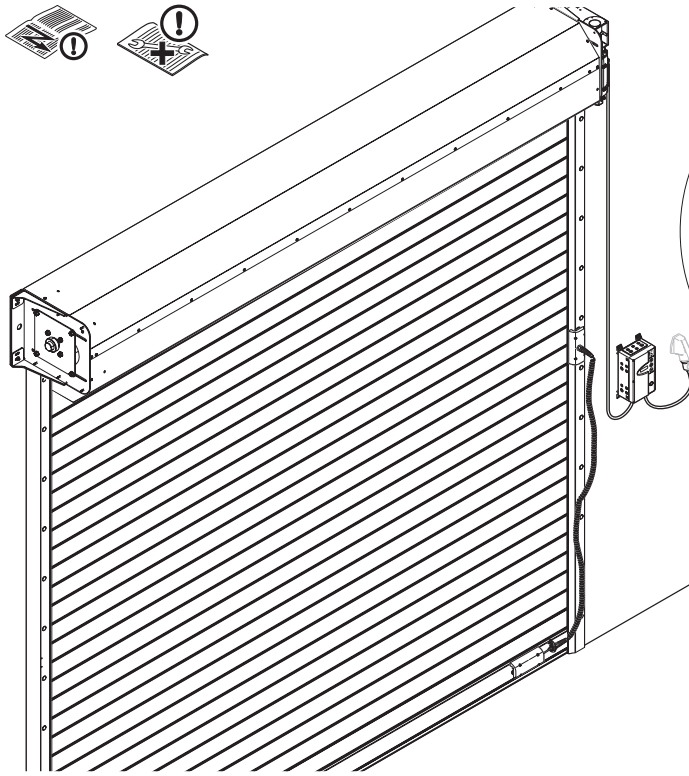
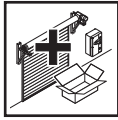

6b.1

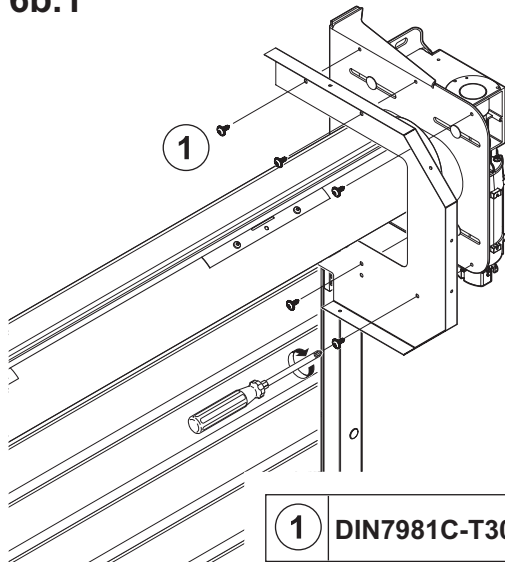

1 DIN7981C-T30 6,3x19

6b.2

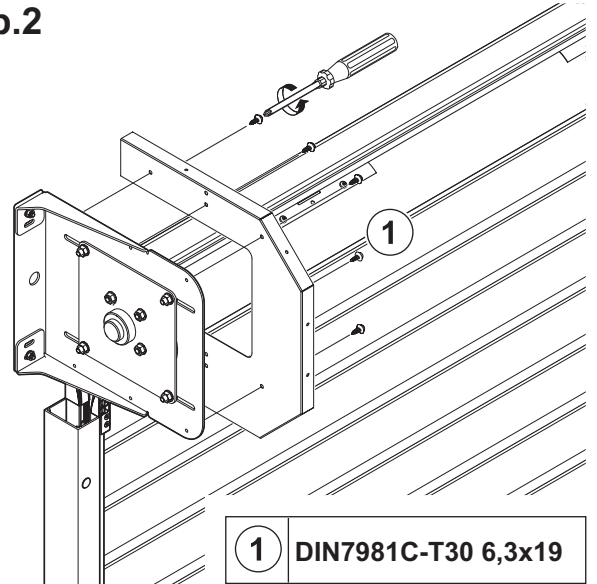

1 DIN7981C-T30 6,3x19

6b.3

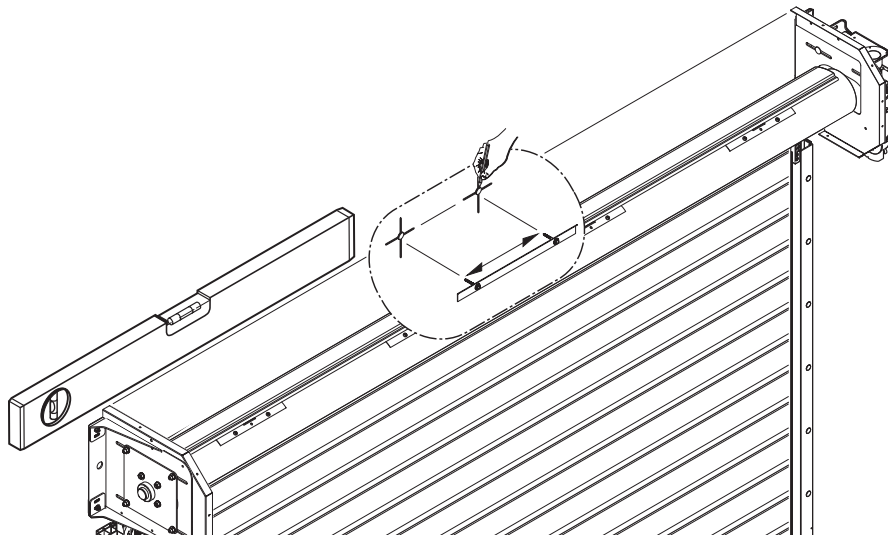

6b.4

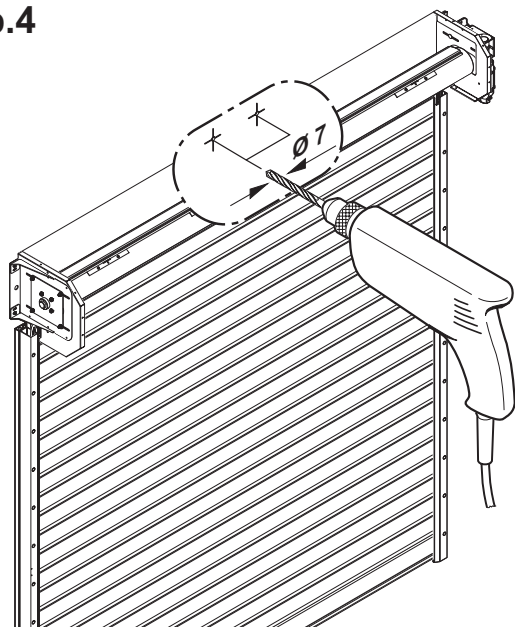

6b.5

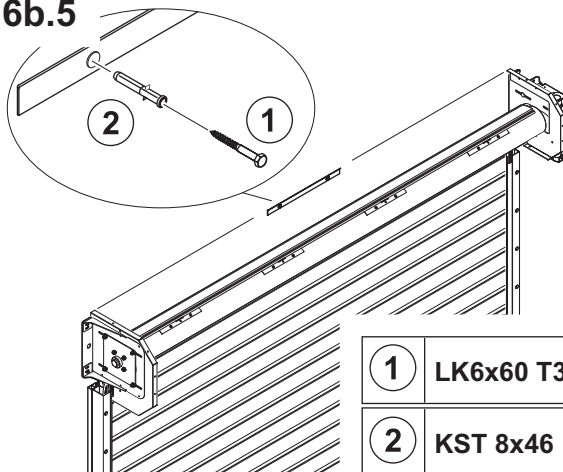

- | | |
|---|------------|
| 1 | LK6x60 T30 |
| 2 | KST 8x46 |

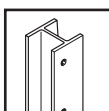

- | | |
|---|---------------------|
| 1 | DIN7981C-T30 6,3x15 |
|---|---------------------|

6b.6

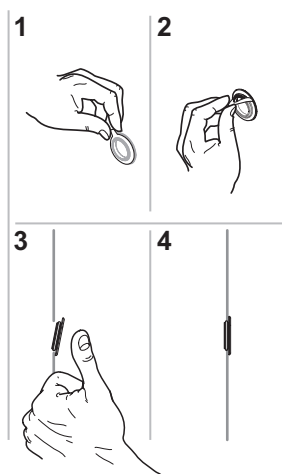
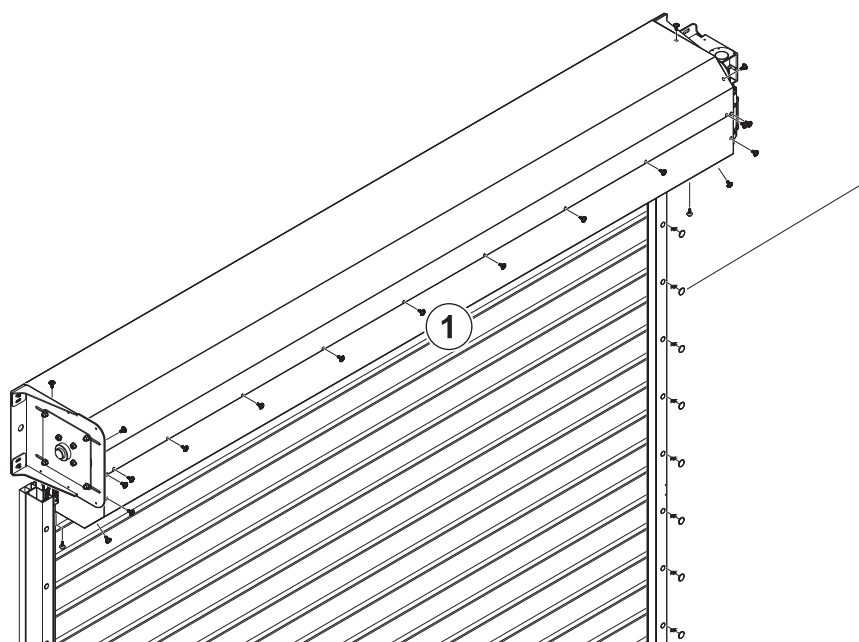
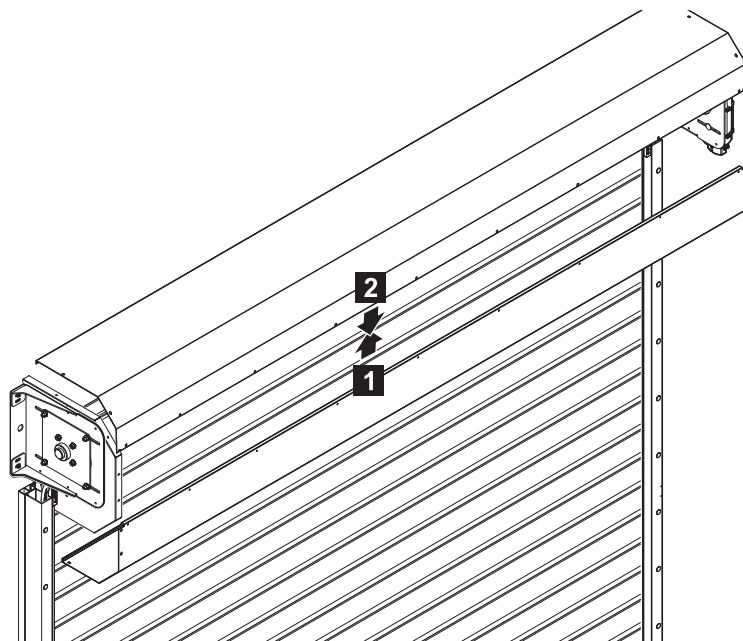

- | | |
|---|------------------|
| 1 | 7981C-T30 6,3x19 |
|---|------------------|

6c

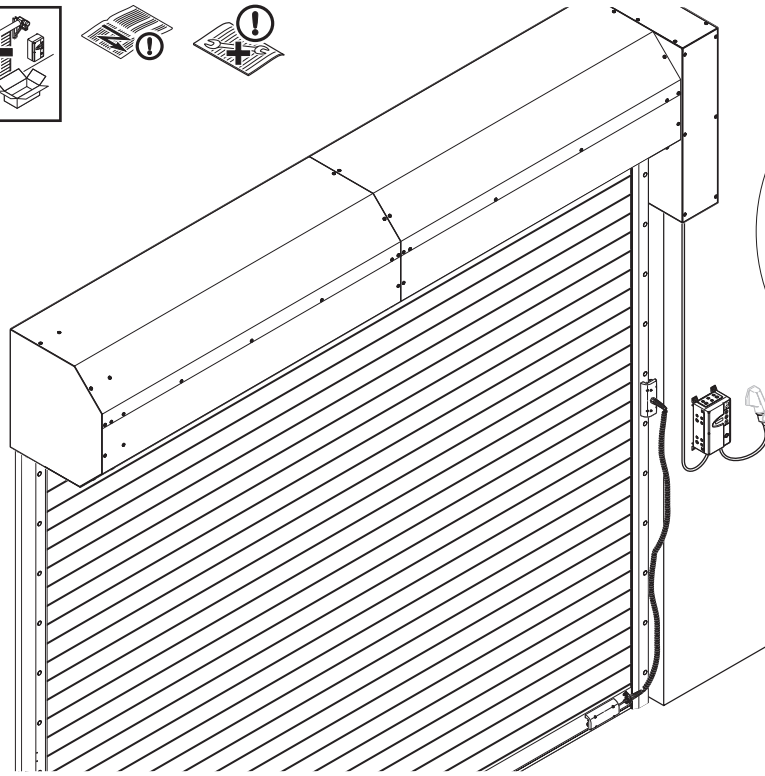

6c.1

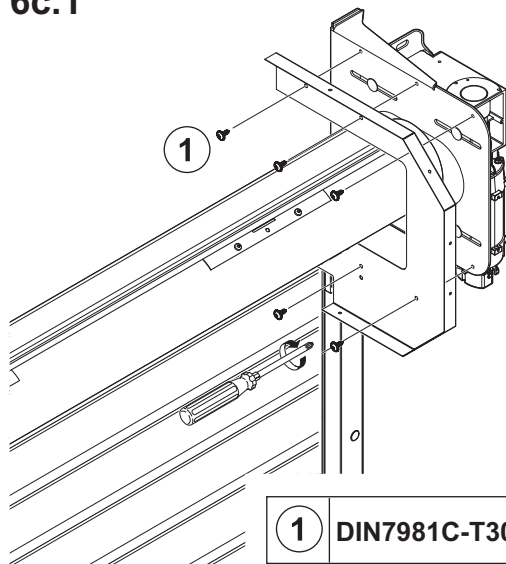

6c.2

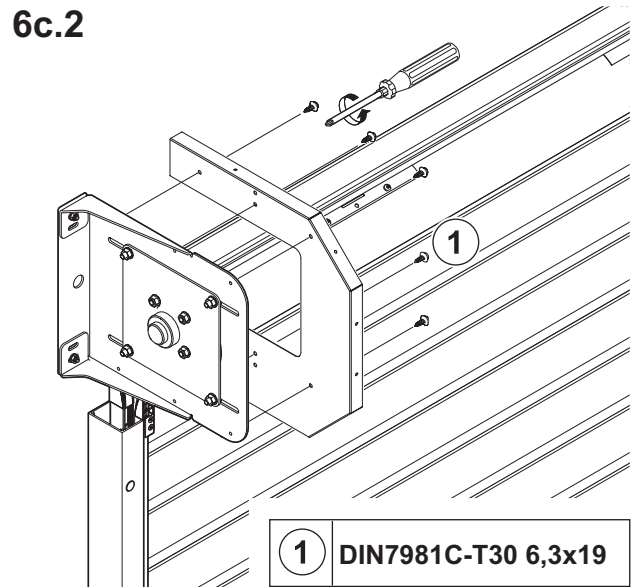

6c.3

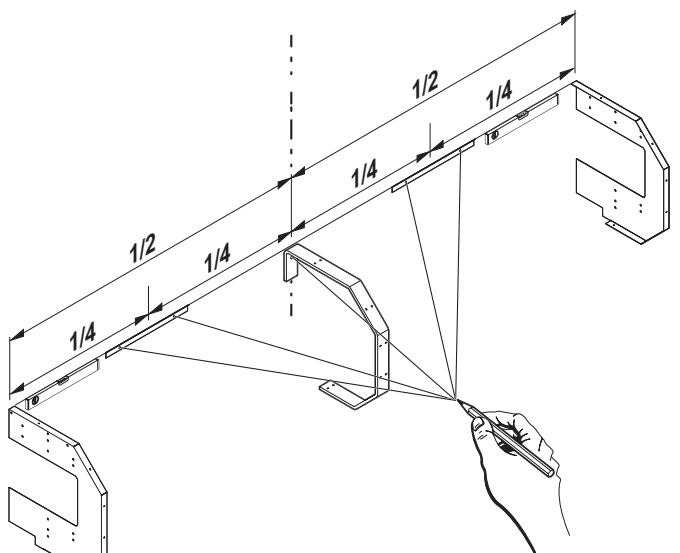
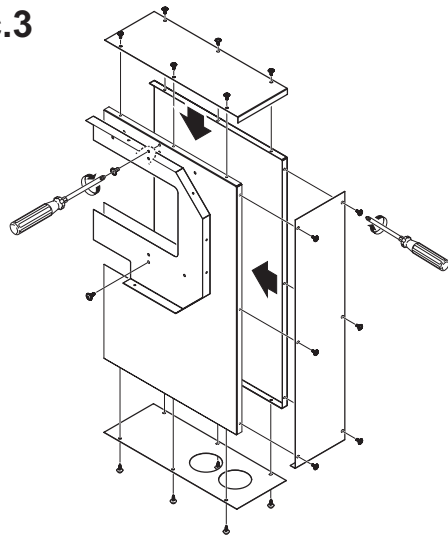

6c.4

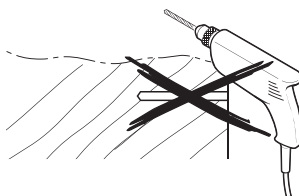
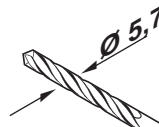
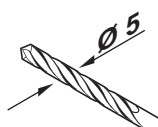
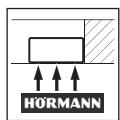
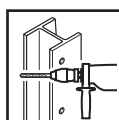
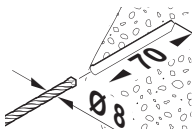
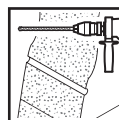
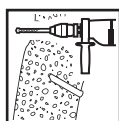
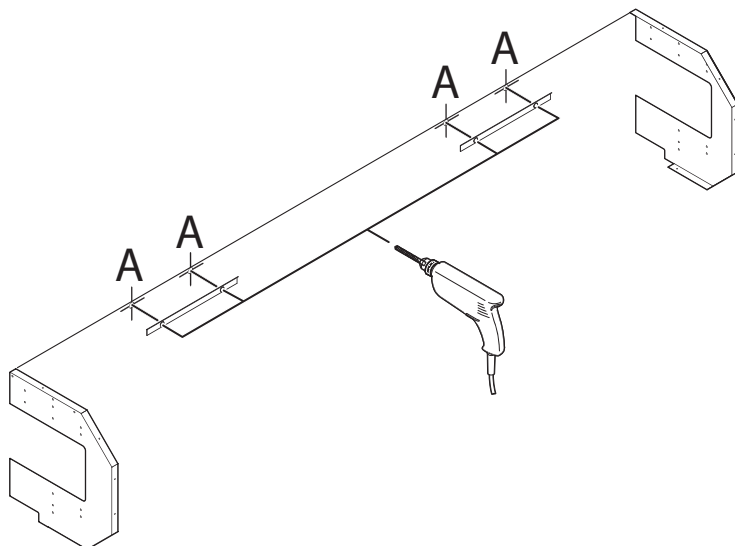

6c.5

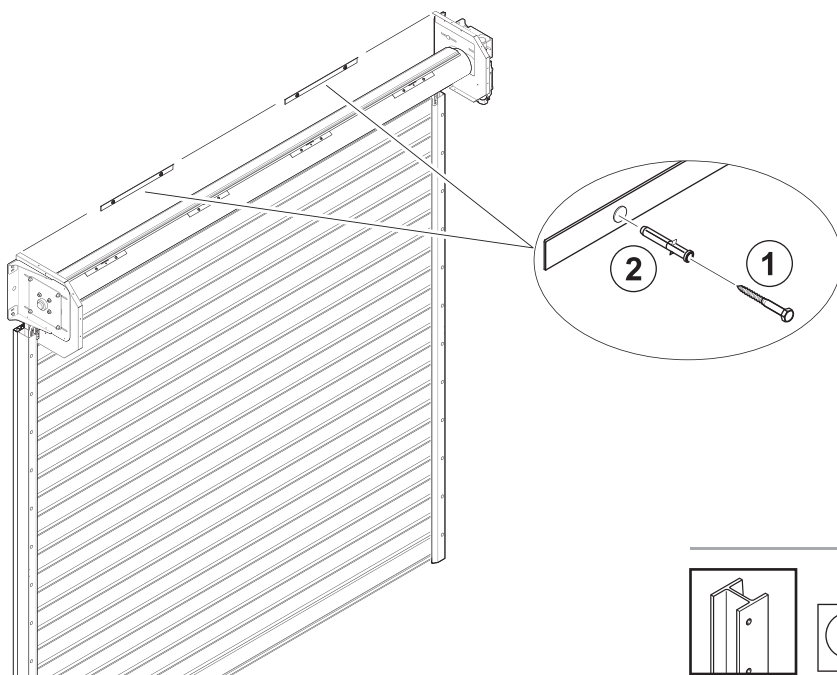

1	LK6x60 T30
2	Shark Pro 8

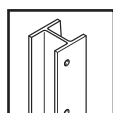

1	DIN7981C-T30 6,3x15
---	---------------------

6c.6

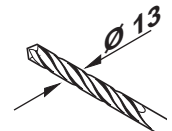
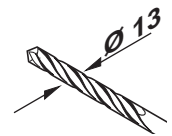
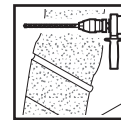
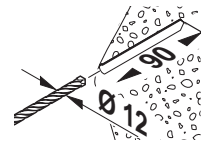
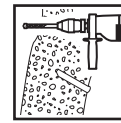
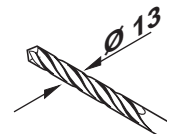
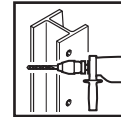
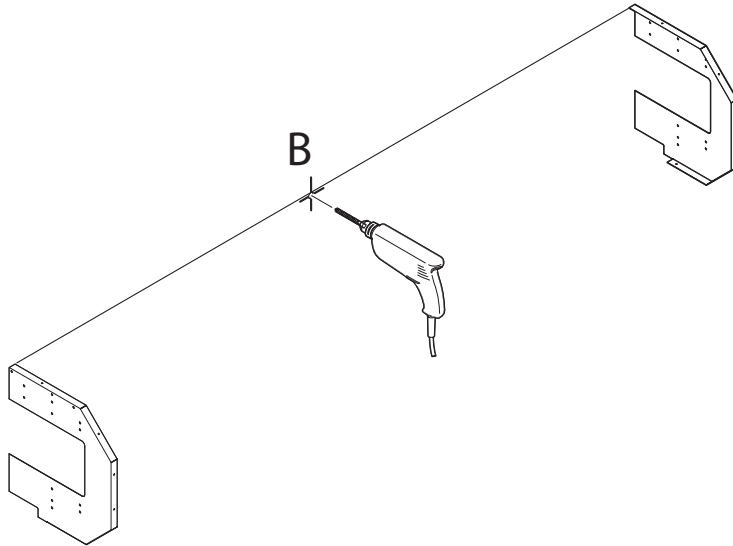

6c.7a

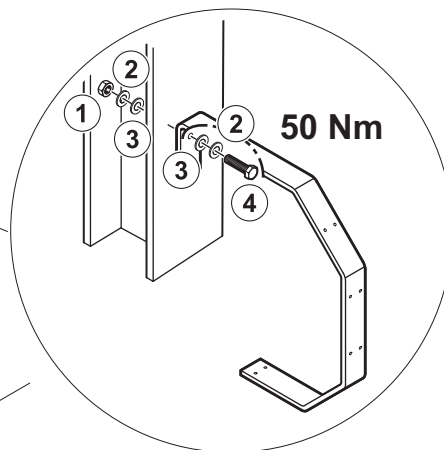
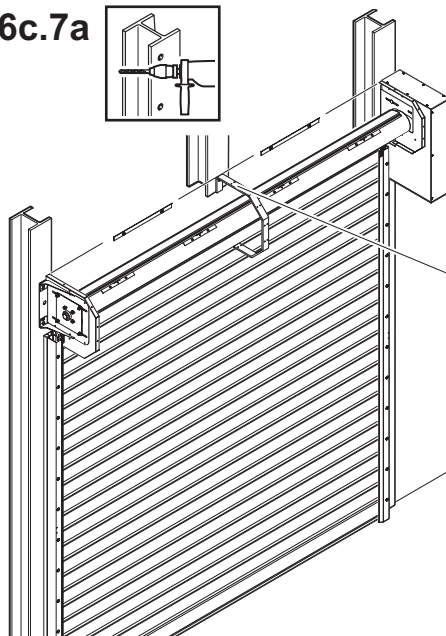

1	DIN 934 M12 A4
2	DIN 125-13-A4
3	DIN 125-13-KS
4	DIN933 M12x50 A4

6c.7b

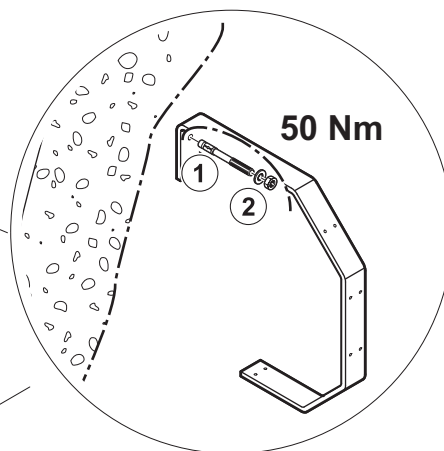
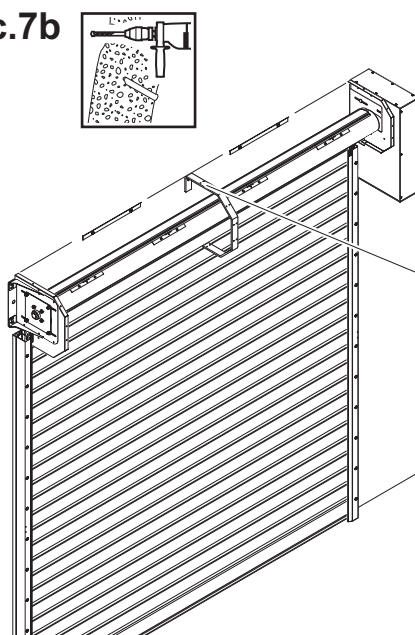

1	W-FAZ M12x110 A4
2	DIN 125-13-KS

6c.7c

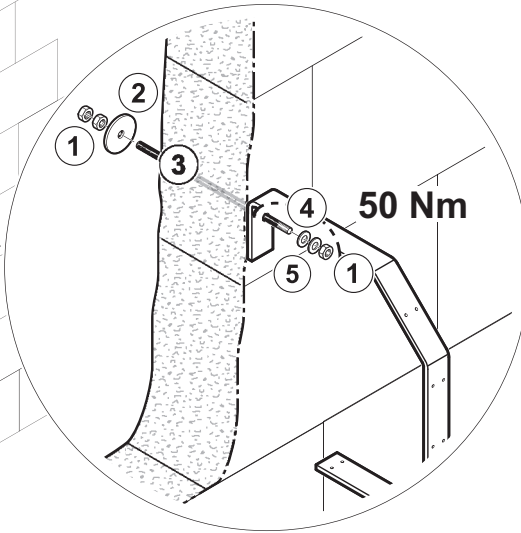
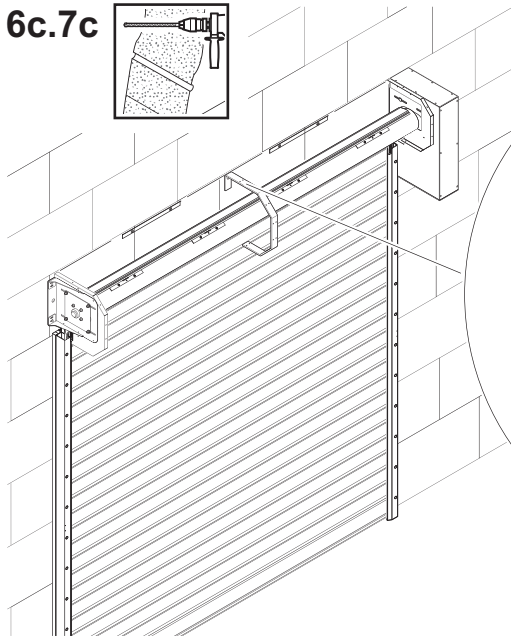
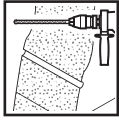

1	DIN 934 M12 A4
2	DIN 440-13-A4
3	M12x500 A4
4	DIN 125-13-KS
5	DIN 125-13-A4

6c.7d

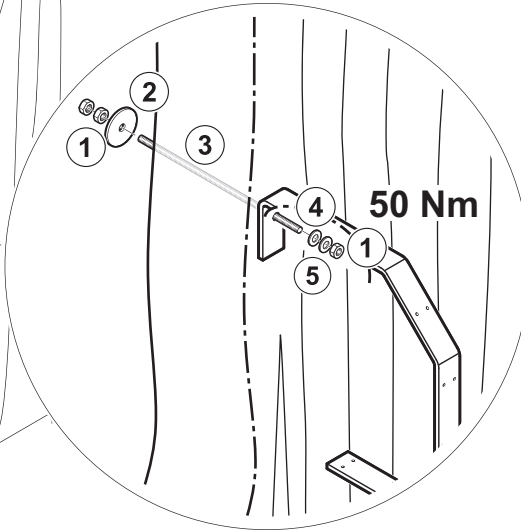
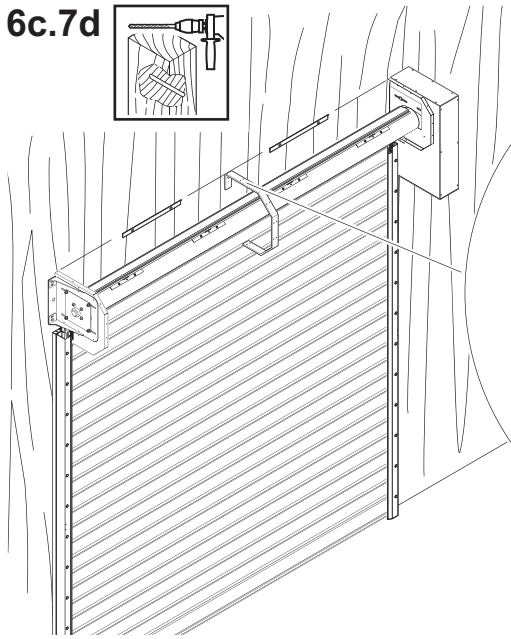

1	DIN 934 M12 A4
2	DIN 440-13-A4
3	M12x500 A4
4	DIN 125-13-KS
5	DIN 125-13-A4

6c.8

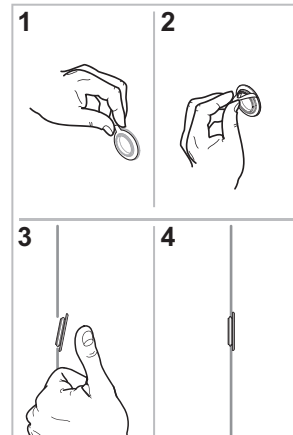
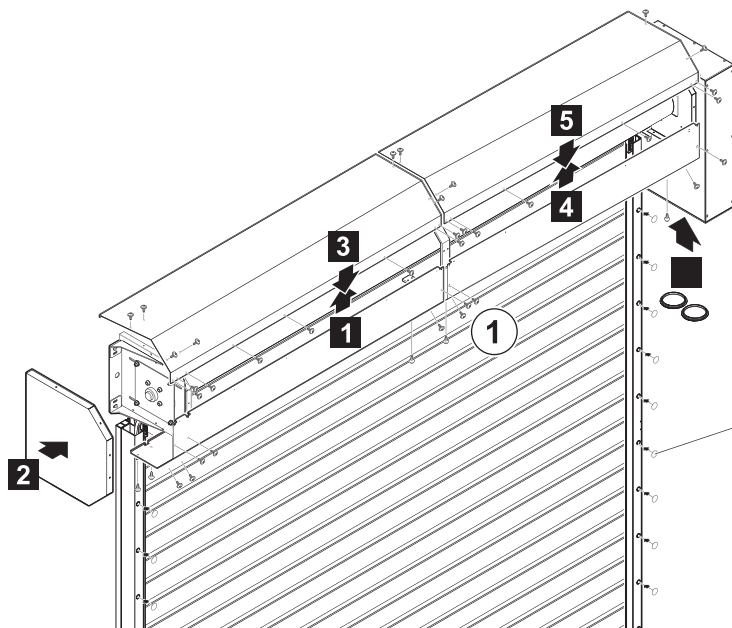

1	DIN7981C-T30 6,3x19
---	---------------------

7

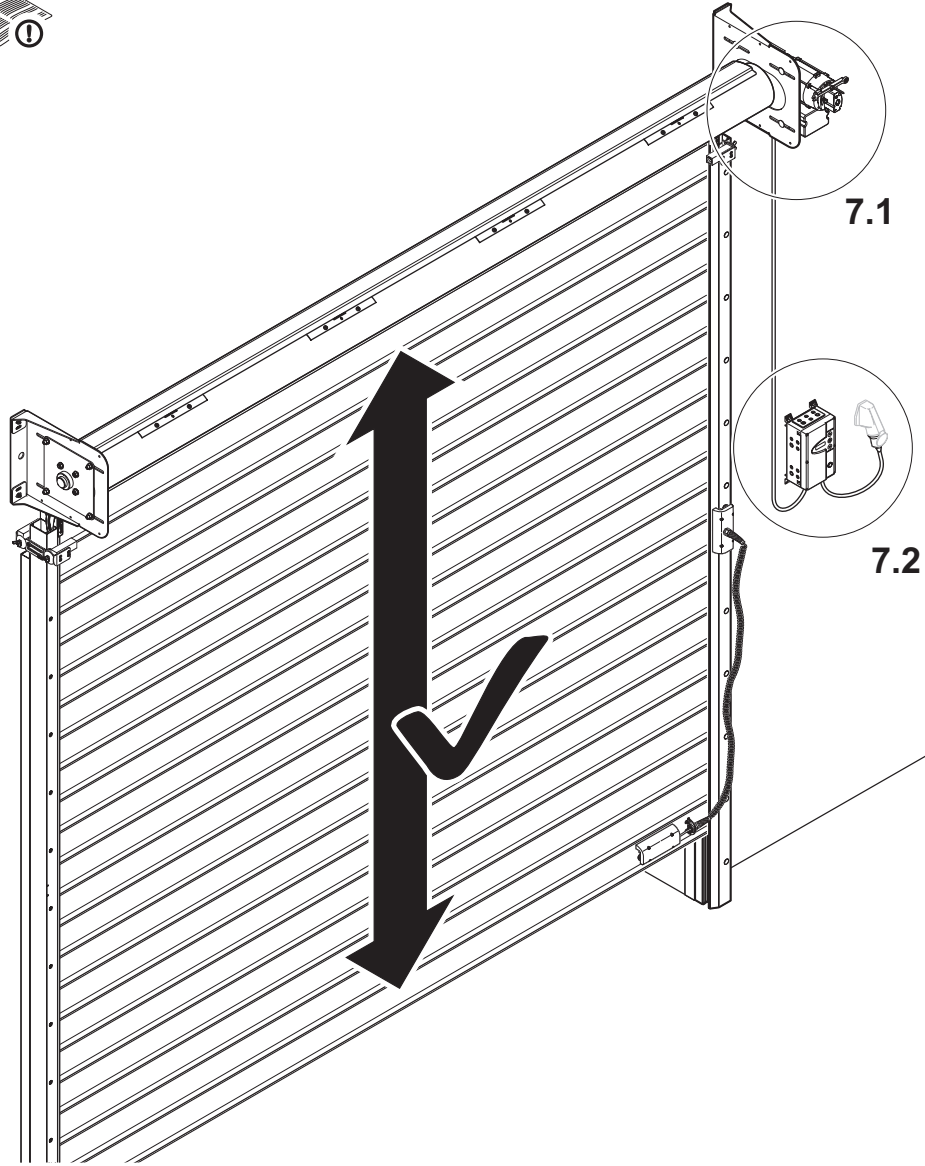

7.1

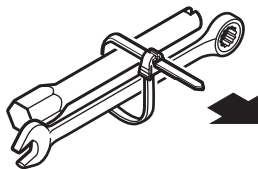

1

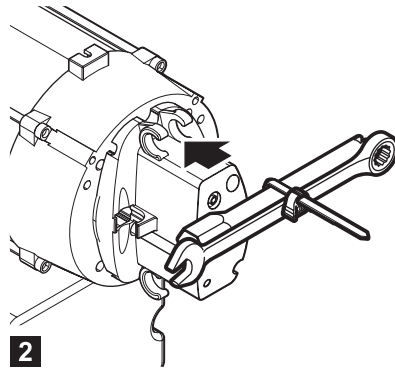

2

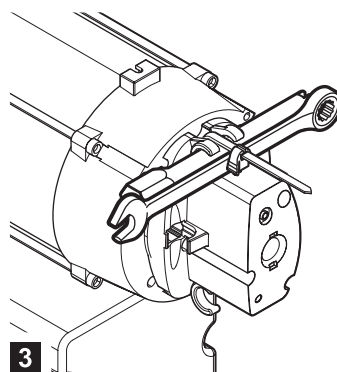

3

7.2

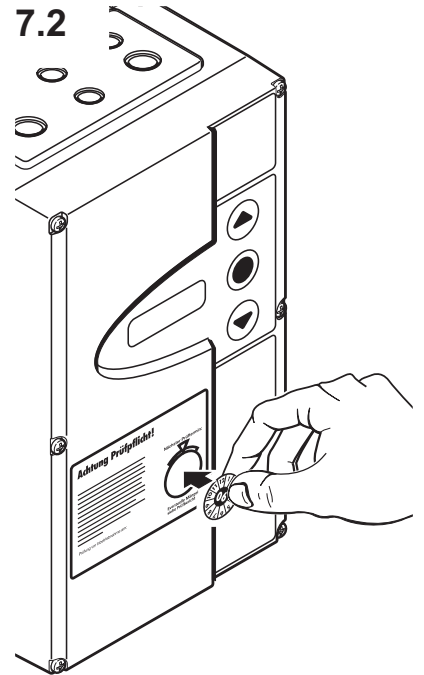

4.5 Control system and control elements

NOTE:

- Only attempt to carry out the electrical installation if you are a qualified electrician or have received adequate instruction from a qualified electrician. More specifically, you must possess the following qualifications:
 - You must recognise the hazards that electricity can cause.
 - You must be familiar with the applicable electrotechnical regulations.
 - You must be able to use and take care of the safety equipment.
 - You know how to give first aid.
- In addition, observe the following instructions:
 - Instructions for fitting, operating and service of the door control
 - Instructions for installation of electrical connections
 - Instructions for fitting additional electrical control elements
- Make sure that the electrical installation complies with the applicable safety requirements.
- Only fit the control under the following prerequisites:
 - The control is within sight of the door.
 - The control is out of the reach of children at a height of at least 1500 mm.

ATTENTION
<p>External voltage or lead damage</p> <p>Electronics can be destroyed by external voltage or damage to the connecting cables.</p> <ul style="list-style-type: none"> ▶ Do not apply any external voltage to the connecting terminals of the control. ▶ Never pull on the connecting cables of the electrical components.

5 Initial start-up

CAUTION
<p>Defective door systems</p> <p>Putting a defective door system into service can lead to injuries and door system damage.</p> <ul style="list-style-type: none"> ▶ Before putting the door into service, check that it is in good working order and free of defects. ▶ Do not put the door system into service if it is defective.

5.1 End-of-travel positions

The door's end-of-travel positions are set at the control.

NOTE:

Observe the instructions for the operator and control.

Set the end-of-travel positions as follows:

CLOSE end-of-travel position

- The bottom profile contacts the floor along the full length
- Max. 5 profiles have travelled into one another
- The rolling grille curtain does not bulge out and hangs straight down.

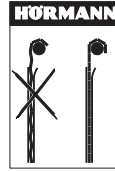

Make sure that no more than 5 profiles travel into one another, otherwise the following problems may occur:

- The door will produce increased noise on opening.
- The closed door is unstable and tends to rattle under heavy wind loads.

WARNING
<p>Exceeding the CLOSE end-of-travel position</p> <p>If the door travels beyond the CLOSE end-of-travel position, there is a risk that the connection between the door curtain and barrel will be damaged, causing the curtain to fall off the barrel. There is a danger of injury and damage to the door system.</p> <ul style="list-style-type: none"> ▶ Set the CLOSE end-of-travel position according to the specifications.

OPEN end-of-travel position

The distance from the FFL to the bottom edge of the bottom profile corresponds to the door height in the data label. The OPEN end-of-travel position is marked with an engraved line on both side guides.

WARNING
<p>Exceeding the OPEN end-of-travel position</p> <p>If the door travels beyond the OPEN end-of-travel position, there is a risk of the door curtain slipping out of the guide rails and sustaining damage. There is also a danger of injury and of damage to the door system.</p> <ul style="list-style-type: none"> ▶ Set the OPEN end-of-travel position according to the specifications.

5.2 Lintel seal

ATTENTION
<p>Dirty lintel seal</p> <p>A dirty lintel seal can damage the surface of the door curtain.</p> <ul style="list-style-type: none"> ▶ Clean the lintel seal immediately after fitting (see <i>Lintel seal</i> on page 43).

5.3 Test run

After fitting is complete, test the functional safety in accordance with the inspection plan (see *Inspection and maintenance plan* on page 41).

Verify in the test log book (dated and signed) that a test run has been successfully completed.

On completing fitting, a test run and the inspection, hand the entire door documentation over to the owner of the door system.

6 Operation

6.1 Safety instructions for door operation

NOTE:

As the operator or owner of the door system, you are responsible for ensuring that all applicable regulations are observed and complied with. You can find the applicable regulations in *Standards and directives to be observed* on page 2.

CAUTION
<p>Danger of injury due to incorrect handling of door system</p> <p>Handling the door system incorrectly can lead to injury. Observe the following safety instructions.</p> <ul style="list-style-type: none"> ▶ You are responsible for ensuring that only suitably instructed persons operate the door. A person is considered instructed if he / she fulfills the following criteria: <ul style="list-style-type: none"> – He / she has been shown how to operate the door safely. – He / she has received permission from you to use the door system. ▶ You are responsible for ensuring that children cannot operate the door system, neither via the control nor the control elements. ▶ Wait until the door has come to a complete halt before walking / driving into the door's area of travel. ▶ Only drive through the door system with working platforms when the working cage is fully lowered. ▶ Never use the door to lift objects and / or persons. ▶ Whenever driving in or out of the opening, always check that the door curtain has travelled up far enough to provide the necessary passage height. ▶ Only ever operate the door system when all the protective devices and safety equipment are fitted and are in perfect working order. ▶ Do not dismantle or alter any of the protective devices. Do not put any of the protective devices out of operation.

ATTENTION
<p>Damage due to incorrect handling of the door system</p> <p>Handling the door system incorrectly can lead to damage to the door system. Observe the following safety instructions.</p> <ul style="list-style-type: none"> ▶ Only use the emergency operation device from a safe position (floor, approved ladder or scaffolding). ▶ Do not hang on the emergency hand chain with your body weight. ▶ Protect the door from aggressive and caustic substances, such as: <ul style="list-style-type: none"> – Nitrous acid action from stone or concrete – Cement, plaster – Acids, alkali – Road salt – Coatings / paint with an aggressive action – Sealants with an aggressive action

NOTE:

Make sure you are familiar with the way the door control, the control elements and the operator work, so you know how to operate these devices properly (see instructions).

6.2 Emergency-off

To effect an emergency stop take the following actions:

- ▶ Pull out the red CEE mains plug to disconnect from the power supply.
or
- ▶ Actuate the red main switch or the emergency-OFF button.

6.3 Emergency operation in the case of safety equipment malfunctioning

In the event of malfunctions or failure of safety equipment, you can operate the door in emergency mode using the press-and-hold function.

Safety equipment includes e.g.:

- Safety edge
- Lintel trap guard
- Safety photocells

NOTE:

In this regard, follow the instructions in the manual supplied with the control.

6.4 Operating conditions

The door system is intended for the following operating conditions:

Temperature range: –20 °C to 40 °C
 Relative humidity: 0% to 60%

6.5 Operating cycles

6.5.1 DD

Decotherm S, HR 120 A, HG-L, HG-V, HG-S		
Operator	Max. permissible cycles per hour	Max. permissible cycles per day
DD17, DD25, DD30, DD50	10	75
DD40, DD65	8	75
DD100	6	75
DD160	5	75
DD180	2	50

HR120 A aero		
Operator	Max. permissible cycles per hour	Max. permissible cycles per day
DD17, DD25, DD30, DD50	10	10
DD40, DD65	8	10
DD100	6	10
DD160	5	10

6.5.2 DD S6

Decotherm S		
Operator	Max. permissible cycles per hour	Max. permissible cycles per day
DD17.60	30	300
DD25.60	20	300
DD40.40	15	300

6.6 Wind load

ATTENTION
<p>Damage to the door system due to wind load The door curtain deflects under wind loads. Door function is not guaranteed and door parts may be damaged during heavy wind loads.</p> <p>▶ Never open or close the door during a wind gust load exceeding 8 Beaufort.</p>

The following conditions may arise due to high wind loads:

- The door curtain can deform permanently.
- The door construction can suffer damage.

Follow these steps after a heavy wind load:

- Inspect the operational safety of the door system (see *Obligation to inspect and maintain* on page 40).
- Repair storm damage before putting the door system back into service (see *Storm damage* on page 41).

6.7 Information on the product characteristics

6.7.1 Abrasion and pressure marks

The design of the DD rolling shutter represents state-of-the-art technology. Pressure marks and abrasive wear, particularly on the top profiles, are design-related and cannot be avoided.

- ▶ In order to avoid excessive abrasion, remove any soiling (e.g. sand, dust, plastic particles etc.) at regular intervals.

NOTE:

Follow the directions for door cleaning and care (see *Cleaning and care* on page 43).

6.7.2 Noise

Opening and closing the door produces a certain degree of noise related to the design.

Increased noise emission could occur under the following conditions:

- extensive soiling of the curtain (see *Cleaning and care* on page 43)
- Incorrectly set door end-of-travel positions (see *End-of-travel positions* on page 38)
- Incorrectly fitted door systems

6.7.3 Window

If conditions are damp and temperatures unfavourable, this can cause the window panes to mist up. This moisture will eventually dissipate and does not cause any long-term damage.

6.7.4 deflection

The curtain is flexible. A slight deflection of the door profiles in the unloaded state does not constitute grounds for concern nor does it impair the function.

Door width [mm]	Deflection [mm]
2000	2
3000	5
4000	8
5000	13
6000	18
7000	25
8000	32
9000	41
10000	50
11000	61
12000	72

Deflection can be significantly increased under heavy wind loads.

7 Inspection and maintenance

7.1 Obligation to inspect and maintain

NOTE:

As the owner or operator of the door, you must have the system inspected and maintained by a specialist once a year – in the case of more than 50 door cycles a day, every 6 months.

 CAUTION
<p>Ignoring the obligation to inspect and maintain The following problems may occur if you do not have the door inspected and maintained as specified:</p> <ul style="list-style-type: none"> • Risk of injury • Risk of damage • Nullification of the warranty <p>▶ Arrange for all the inspections and maintenance work to be carried out by a specialist company.</p>

7.2 Malfunctions and damage remedy

In the case of malfunctions call in a qualified specialist immediately to inspect and repair the door system.

7.3 Original spare parts

Only use original spare parts. They always meet the technical requirements laid out by us.

7.4 Wearing parts

 WARNING
Failure to replace wear parts
Failure to replace wear parts can result in damage to the door construction and life-threatening injuries.
▶ Replace wear parts at the specified time.

7.4.1 Roller garage door DD

Component	Exchange after
Curtain Decotherm S	80,000 cycles
Curtain HR 120 A	80,000 cycles
Curtain HR 120 aero	20,000 cycles
Curtain HG-L	80,000 cycles
Curtain HG-V	80,000 cycles
Curtain HG-S	80,000 cycles
Barrel	80,000 cycles
Guide rail funnel	80,000 cycles
Operator	500 operating hours
Coiled cable	40,000 cycles

7.4.2 Rolling shutter DD S6

Component	Exchange after
Curtain Decotherm S	200,000 cycles
Top 5 profiles	80,000 cycles
Barrel	200,000 cycles
Guide rail funnel	80,000 cycles
Operator	500 operating hours

7.5 Operator power

The voltage of the power supply must be 95% of the operator's supply voltage. Any voltage lower than this can lead to malfunctions in operating the door.

7.6 Storm damage

Examine the following parts of the door system after wind loads of 8 Beaufort or greater:

Component	Test criterion	OK
Door curtain	1. No permanent deformations which could impair operation of the door (e.g. curtain rolling up unevenly or obliquely)	
End pieces with wind locks	1. No torn-out wind locks 2. No visible strain on the connection between wind lock end pieces and profile	
Guide rails	1. No deformation 2. Firmly seated on the building structure	

- ▶ If the wind locks have torn out, replace the end locks and the profiles concerned.

7.7 Locking cylinder

ATTENTION
Damage to the locking cylinders due to unsuitable cleaning products
Locking cylinders may not be cleaned with agents containing oil or be greased.
▶ Only use specialised care products.
▶ Do not use oil or graphite.

7.8 Inspection and maintenance plan

NOTICES:

Please observe the following:

- The applicable regulations governing workplace safety when carrying out inspections and maintenance
- the notes in section *Basic Safety Instructions* on page 4
- All inspection and maintenance information relating to the accessories

 CAUTION
Actuation by other persons
Actuating the door system while inspecting or performing maintenance work can lead to injuries and damage.
▶ Make sure that whenever checks, maintenance work and cleaning are being carried out, the door system cannot be actuated by other persons.
▶ Follow all the inspection and maintenance information relating to the accessories.

Only inspect and maintain this door if you are a specialist. In other words, you have the suitable training, specialist knowledge and practical experience to allow you to carry out inspection and maintenance correctly and safely.

NOTE:

In normal operating conditions all the bearings, including the gearbox, are lubricated for life and are maintenance-free.

Component	Test criterion	OK
Guide rails	1. No deformation 2. Undamaged 3. Firmly fastened to the building structure 4. Fixing material complete 5. Tightening torque of the fixing material meets the requirements	
Slider profiles	1. No deformation 2. Undamaged 3. Bristle seal fitted ¹⁾ 4. Bristle seal has not been pulled out	

Component	Test criterion	OK
Rolling shutter curtain	<ol style="list-style-type: none"> 1. No collision damage 2. No increased abrasive wear or pressure marks 3. Undamaged 4. No unusual soiling (sand, chemicals) 5. Curtain runs smoothly into the side guides 	
Rolling grille curtain	<ol style="list-style-type: none"> 1. No collision damage 2. No bulging 3. Honeycomb connections undamaged 4. No unusual soiling (sand, chemicals) 	
End pieces¹⁾	<ol style="list-style-type: none"> 1. Complete 2. Undamaged 3. Firmly seated on the profiles 4. Fixing material undamaged 	
Wind locks / pull-out protection	<ol style="list-style-type: none"> 1. Complete 2. Do not touch each other when door curtain rolls up 3. With HR116 profiles: rubber bearings undamaged 	
Screw-on fixing brackets	<ol style="list-style-type: none"> 1. Complete 2. Not bent up 3. No slotted holes present 4. Firmly seated on the barrel 5. Fixing material complete 	
bottom profile	<ol style="list-style-type: none"> 1. Undamaged 	
Data label	<ol style="list-style-type: none"> 1. Available 2. Undamaged 	
Bottom seal	<ol style="list-style-type: none"> 1. Undamaged 	
Support brackets	<ol style="list-style-type: none"> 1. No deformation 2. Fixing material complete 3. Tightening torque meets the requirements 4. Weld seams are undamaged 5. Distance from the centre of the barrel to the lintel is according to the specifications 	
Operator	<ol style="list-style-type: none"> 1. No unusual sounds when running 2. No oil leaks 3. Working temperature normal 4. Fixing material complete 5. Tightening torque of the fixing material meets the requirements 	
Bearings	<ol style="list-style-type: none"> 1. Fixing material complete 2. Tightening torque of the fixing material meets the requirements 	

Component	Test criterion	OK
Barrel	<ol style="list-style-type: none"> 1. Horizontally balanced and aligned 2. Undamaged 3. Smooth running 4. No subsequent changes 	
barrel journal	<ol style="list-style-type: none"> 1. Fully seated in the bearing 2. Fully seated in the operator 	
Distance sleeves	<ol style="list-style-type: none"> 1. Complete 2. Undamaged 3. No axial displacement possible 	
Lintel seal¹⁾	<ol style="list-style-type: none"> 1. Undamaged 2. No heavy soiling present 3. Fixing material complete 4. Tightening torque of the fixing material meets the requirements 	
Door position and safety limit switch	<ol style="list-style-type: none"> 1. Setting meets the requirements 2. Function properly 3. At the CLOSE end-of-travel position no more than 3 – 4 profiles have travelled into one another 	
Manual operation (Service and fitting adapter or emergency hand chain)	<ol style="list-style-type: none"> 1. Available 2. In perfect working order 	
Control	<ol style="list-style-type: none"> 1. Housing undamaged 2. No moisture in the control 3. Membrane push buttons working 4. Switch-off devices in the control cover (miniature lock, main switch, etc.) are in perfect working order 5. CEE plug is easy to disconnect 	
Wiring	<ol style="list-style-type: none"> 1. Conforms to standard 2. Leads undamaged 3. Cable glands OK 	
Safety edge²⁾	<ol style="list-style-type: none"> 1. In perfect working order 2. Cable and housing undamaged 3. Setting of closing edge safety device STOP position meets the requirements 	
Light grille²⁾	<ol style="list-style-type: none"> 1. In perfect working order 2. Cable and housing undamaged 3. Lenses are clean 4. Fixing material complete 5. Tightening torque of the fixing material meets the requirements 	

Component	Test criterion	OK
Roll-up safety device²⁾	<ol style="list-style-type: none"> 1. In perfect working order, no impermissible reflection 2. Cable and housing undamaged 3. Position of photocells meets the requirements 4. Lenses are clean 	
Radio control²⁾	<ol style="list-style-type: none"> 1. In perfect working order 	
Lockable bottom profile²⁾	<ol style="list-style-type: none"> 1. Undamaged 2. In perfect working order 3. Safety switch at correct setting and properly connected 	
Shootbolt²⁾	<ol style="list-style-type: none"> 1. Undamaged 2. In perfect working order 3. Safety switch at correct setting and properly connected 	
PVDD²⁾	<ol style="list-style-type: none"> 1. Undamaged 2. Fixing material complete 3. Tightening torque of the fixing material meets the requirements 	
Fascia panel²⁾	<ol style="list-style-type: none"> 1. Undamaged 2. Fixing material complete 3. Tightening torque of the fixing material meets the requirements 	

- 1) This component is not used on a rolling grille or the test criterion is not applicable
 2) Optional components

8 Cleaning and care

To preserve the surface characteristics, regular cleaning must be carried out at least every 3 months (door curtain, seals).

Contact with aggressive media (acids, alkali, salts, etc.) must always be avoided. If, however, the door surface or the attached parts are contaminated, they must immediately be rinsed completely of any residue using clear water.

ATTENTION
<p>High-pressure cleaner</p> <p>Cleaning the door system with a high-pressure cleaner can lead to door system malfunctions and damage.</p> <ul style="list-style-type: none"> ▶ Do not use any high-pressure cleaners for cleaning the door system.

8.1 Door curtain

- Use warm water together with a neutral, non-abrasive cleaning agent (household detergent, pH value 7)
- To clean the surface, use only a soft cloth or chamois.
- Rinse off any dirt and dust particles with clear water.

ATTENTION
<p>Rubbing panes dry</p> <p>Scratches may occur.</p> <ul style="list-style-type: none"> ▶ Do not rub panes dry.

8.2 Lintel seal

Remove dust and dirt at regular intervals.

8.3 Safety equipment and photocells

Clean the lenses and reflectors regularly with a soft, dry, lint-free towel. Soiled optics can impair function.

9 Extension and conversion

 WARNING
<p>Use of non-authorized components</p> <p>Non-authorized components could overload the door construction. This could lead to serious injuries and damage.</p> <ul style="list-style-type: none"> ▶ Any conversion of the door system requires the express permission of the manufacturer. ▶ Only use components that have been approved by the manufacturer.

NOTE:

Carrying out any structural alterations to the product without the manufacturer's permission renders the warranty and product liability null and void.

10 Dismantling

NOTE:

When dismantling the system, observe the applicable regulations governing workplace safety.

1. Open the door completely.
2. Carefully roll up the door (manual operation).
3. Tape round the door barrel several times with strong adhesive tape (e.g. packing tape) to prevent it from unrolling.
4. Drive a forklift with suitable pallet underneath the door barrel so that the door barrel lies on the pallet.
5. Loosen the fastenings of the support brackets from the building structure.

CAUTION!

The operator or the bearing can slip off the barrel journal.

- ▶ When letting the door curtain down, take care to keep it horizontal.
6. Let the door curtain with support brackets and operator down on the floor.
 7. Disassemble the side guides.
 8. Dismantle the door into component parts and dispose of them properly.

Dissemination as well as duplication of this document and the use and communication of its content are prohibited unless explicitly permitted. Noncompliance will result in damage compensation obligations. All rights reserved in the event of patent, utility model or design model registration. Subject to changes.

Hörmann KG Verkaufsgesellschaft
Upheider Weg 94 – 98
33803 Steinhagen
Germany
www.hoermann.com