

## TST WU

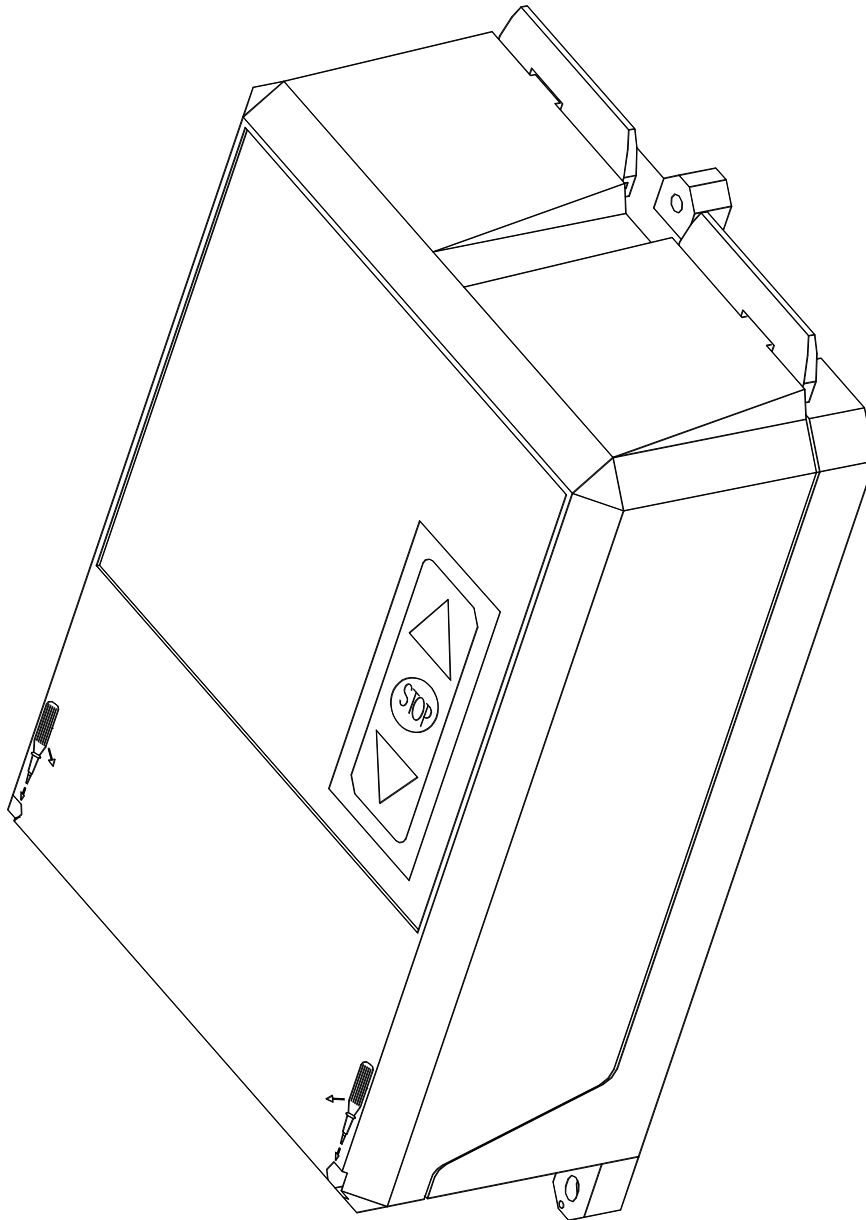

### **Important !**

**You must read the function description before operating,  
connecting or starting up the door controller**

## Notes

© Copyright 2003 by  
Hörmann KG Verkaufsgesellschaft  
D-33803 Steinhagen  
<http://www.hoermann.de>

This edition replaces all earlier versions.

The specifications contained in this document may be changed without prior notice.

Transmission and reproduction of this document, use and revealing of its contents are not permitted without express consent. Violations will result in liability for damages. All rights reserved in case of patent granting or utility model listing.

This Manual is directed especially at persons involved with starting up / commissioning the TST WU door controller of Hörmann KG Verkaufsgesellschaft. Starting up the controller must be carried out only by officially trained electrical experts who are familiar with the safety standards of electrical drive and automation technology.

The entity which has placed the TST WU door controller in service is solely responsible for the completeness of the startup manual.

This Manual shows only a small range of the controller functions. Further functions and descriptions for individual door functions as well as more exact specifications for the controller and hazard notes can be found in the main description.

The collecting of information in this document has been done to the best of our knowledge and with due diligence. Hörmann KG Verkaufsgesellschaft does not warrant the correctness and completeness of the information in this document. In particular, Hörmann KG Verkaufsgesellschaft cannot be held liable for following damages due to faulty or incomplete information.

Since mistakes can never be completely avoided in spite of our best efforts, we always welcome feedback. The installation recommendations contained in this document presume favorable surrounding conditions. Hörmann KG Verkaufsgesellschaft assumes no liability for perfect function in environments alien to the system.

Hörmann KG Verkaufsgesellschaft provides no warranty that the information in this document is free of foreign copyrights. Hörmann KG Verkaufsgesellschaft does not grant any licenses for its own or foreign patents or other copyrights in connection with this document. Warranty claims against Hörmann KG Verkaufsgesellschaft are the right of the direct contractual partner only and are not transferable. Warranty is assumed only for the products supplied by Hörmann KG Verkaufsgesellschaft. There is no warranty for the overall system.

The description of products, their use, possibilities and performance data are not to be taken as assured properties and are subject to technical changes.

### General notes concerning this document

The following symbols are used in this function description to alert the user to various hazards and useful tips.

 **WARNING** alerts to a possible hazard to persons if the procedure is not performed as described.

 **ATTENTION** alerts to possible damage to the controller.

 **IMPORTANT** alerts to information which is important to the function of the door controller or door.

 refers to useful information which is useful but not absolutely necessary for using the TST WU door controller

## Contents

<b>1</b>	<b><i>Safety advisories</i></b>	<b>4</b>
<b>2</b>	<b><i>Technical Data</i></b>	<b>6</b>
<b>3</b>	<b><i>Installing the Controller</i></b>	<b>7</b>
<b>4</b>	<b><i>Electrical Connection</i></b>	<b>8</b>
4.1	Connecting the supply voltage .....	8
4.2	Motor connections.....	9
4.3	Connecting the safety edge.....	9
4.4	Connecting limit switches .....	10
4.4.1	Absolute encoder.....	10
4.4.2	Mechanical limit switches .....	10
<b>5</b>	<b><i>General instructions for parameterizing</i></b>	<b>11</b>
<b>6</b>	<b><i>Basic Settings</i></b>	<b>12</b>
6.1	Automatic querying of the basic data .....	12
6.2	Changing parameters.....	13
<b>7</b>	<b><i>Startup...</i></b>	<b>13</b>
7.1	... using absolute or incremental encoders .....	13
7.2	... using mechanical limit switches.....	14
7.3	New request for teaching end positions .....	14
<b>8</b>	<b><i>Additional connection possibilities</i></b>	<b>15</b>
8.1	Photo eye.....	15
8.2	External triggering devices .....	15
<b>9</b>	<b><i>Overview of outputs</i></b>	<b>15</b>
<b>10</b>	<b><i>Functions</i></b>	<b>16</b>
<b>11</b>	<b><i>Message Overview</i></b>	<b>18</b>
11.1	Internal system-related errors F.9xx.....	20
11.2	Information messages .....	21

---

## 1 Safety advisories

---

**When starting up and operating the controller, the following important safety advisories as well as the installation and wiring notes must be strictly observed:**

- All installation, startup and maintenance work must be performed only by qualified specialists. In particular the following regulations must be observed : VDE0100, EN 50110 (VDE0105), EN 60204 (VDE0113), EN 50178 (VDE0160), EN 60335 (VDE0700), fire protection codes, accident prevention regulations as well as the relevant regulations for industrial doors (ZH1/494, EN12453, EN12978)
- The controller may be opened only if the supply voltage has been switched off completely.
- If the potential free contacts of the output relays or other terminals are supplied by a foreign voltage witch are still present after switching off the controller, you must install a sign on the housing that says: "ATTENTION! You must disconnect all supply circuits before opening the housing".
- The controller must never be operated while open.
- The controller must never be operated without the CEE-plug except that a main switch is installed. The main switch and the CEE-plug must be within easy reach.
- If the connecting lead is damaged, it must be changed by the manufacturer or another qualified person.
- Hazardous voltages remain stored in the intermediate circuit capacitors for up to five minutes after power has been turned off. The discharge time until voltages fall below 60VDC is a maximum of 5 minutes. Touching internal controller components within this discharge time is hazardous.
- A defective switching power supply can considerably increase the discharge time of the intermediate circuit capacitors down to a voltage of less than 60VDC. Here discharge times of up to 10 minutes may be possible.
- In case the 24V controller voltage is short circuited or overloaded, the switching power supply will not start up even though the intermediate circuit capacitors are charged. The display and LED's remain off. The power supply can be restarted only after eliminating the short circuit or extreme overload.
- After turning off the supply, the power supply is still fed from the intermediate circuit capacitors for several seconds and maintains the supply function for a certain time depending on the power supply load.
- The processor circuit with 7-segment display, EPROM and multiplexers is galvanically directly connected to the mains supply. Note this when making any checking measurements (for measurements in the processor circuit, do not use test equipment with PE reference to the measuring circuit).
- It is not permitted to operate the controller without a connected protection earth. The absence of a protection earth will result in hazardous voltages on the controller housing caused by drain capacitors. The protection earth should be connected in compliance with EN50178 Section 5.2.11.1 for drain currents >3.5mA.
- Turning on or operating the controller in the presence of condensation is not permitted and may result in permanent damage.
- If controllers are used outside the specified temperature range, a regulated and monitored climate controller system must be in place to ensure that the specified working temperature range is maintained when turning on the supply and when operating the controller.
- The controller must never be operated with a damaged membrane keypad or sight glass. Damaged keypads and windows must be replaced. To prevent damage to the keypad, do not use pointed objects to actuate the keys. The keypad is designed for finger operation only.
- Before tuning on the controller voltage for the first time, ensure that the processor cards (plug-in modules) are in the correct position. Incorrect fit of the cards can result in damage to the controller, likewise the installation of non-approved third-party equipment.
- When moving the door in deadman mode, ensure that the door area can be inspected by the operator, since in this mode safety equipment such as safety bar and light barrier are defeated.
- Parameter settings and the function of the safety devices have to be checked before operating the door.  
Parameter settings and wire bridges are only allowed to set by an instructed person.

 **WARNING** Failure to observe the safety advisories can result in physical harm or damage to the controller.

These safety advisories make no claim to completeness. If you have questions about the product, contact your vendor.

The manufacturer has carefully checked and inspected the device hardware and software, but no warranty is given for a complete absence of errors.

A device mark (nameplate with name and address of the manufacturer, serial number, model number, supply voltage and temperature range) must be applied by the user.

## 2 Technical Data

Housing dimensions (W x H x D):	WxHxD: 180x 320 x 120mm	
Installation:	Using wall attachment on housing bottom, vertical orientation	
Supply voltage over L3, N, PE:	230 VAC $\pm 10\%$ , 50...60 Hz permissible range: 200...240V $\pm 10\%$ / 50...60Hz.	
Controller idle current	Max. 30W fully configured	
External supply (230 V):	230 VAC $\pm 10\%$ , 50...60 Hz (Fuses on the circuit board: 2x 0,5AT)	
Controller voltage / external supply 2:	24 V <sub>DC</sub> ( $\pm 20\%$ at nominal load 500mA and nominal voltage 230 V) max. 500 mA incl. optional plug-in modules. protected by means of self-resetting semiconductor fuse. Short circuit protected using central switching regulator.	
External supply voltage 12V	Nominal value 11.3V $\pm 5\%$ , regulated, max. 150mA	
Controller inputs:	24 VDC / typ.15 mA All inputs must be connected potential-free or: < 2 V: inactive $\rightarrow$ logical 0 > 17 V: active $\rightarrow$ logical 1 min. Signal duration for input controller commands: > 100 ms	
IN1 ... IN8 (with TST RWU: IN11 ... IN18)		
IN9 ... IN10:	< 5V: inactive $\rightarrow$ logical 0 > 16V active $\rightarrow$ logical 1 max. frequency by use as incremental input: < 1kHz / channel	
RS485 A and B:	For electronic limit switches only. RS485 level, terminated with 100 $\Omega$ .	
Safety chain / Emergency-STOP	All inputs must be connected potential-free < 15V: inactive $\rightarrow$ logical 0 > 17V: inactive $\rightarrow$ logical 1 Contact load capacity: $\geq 35$ VDC / $\geq 200$ mA When the safety chain is interrupted no movement of the drive is possible, not even in deadman Not jumpered from the factory	
Safety edge input:	For electrical safety edges with 1.2k $\Omega$ or 8.2k $\Omega$ terminating resistor and for dynamic optical systems.	
Relay outputs	If inductive loads are switched (e.g., additional relays or Breaks), these must be equipped with recovery diodes and the appropriate noise suppression measures.	
Relays K1 and K2: (with TST RWU: K3 ... K6)	Changeover contact, potential-free $\Rightarrow$ 24VDC / 500mA $\Rightarrow$ 230VAC / min. 0,1A / max. 80W	<b>Contacts used once for power switching are no longer capable of switching small currents.</b>
Drive output:	3x 400VAC, max. 2,2KW with AC-3 Contactor prepared for the use of three phase motors. Max. length of motor cable: 30m	
Electro mechanical break	230VAC switched motor phase and N	
Temperature range	Operating:	-10...+50°C
	Storage:	-20...+70°C
Humidity	Up to 95% non-condensing	
Vibration	Low-vibration mounting, e.g. on a plastered wall	
Enclosure rating	IP54	
Weight	Approx. 2,8 kg	
Directives	Standards:	
EMC Directive: modified by:	89/336/EEC 91/263/EEC 92/031/EEC 93/068/EEC	EN 50081-1 / 03.93: Noise emission, residential EN 50081-2 / 03.94: Noise emission, industrial EN 50082-2 / 2001: Noise immunity, industrial
Low-Voltage Directive: modified by:	73/023/EEC 93/068/EEC	EN 60335-1 / 2003: Safety of Electrical Devices for Home Use and Similar Purposes / Part 1: General Requirements
Utility Model tested according to:	EN12453 / 2001:  EN12445 / 2001:	Utilization Safety of Power Activated Doors – Requirements  Utilization Safety of Power Activated Doors – Testing Procedures
Applied national technical specifications related to the above Directives	EN12978 / 2003:	Doors – Protection Equipment – Requirements and Testing Procedures

### 3 Installing the Controller

#### **⚠ WARNING**

The system must be switched off while installing the controller

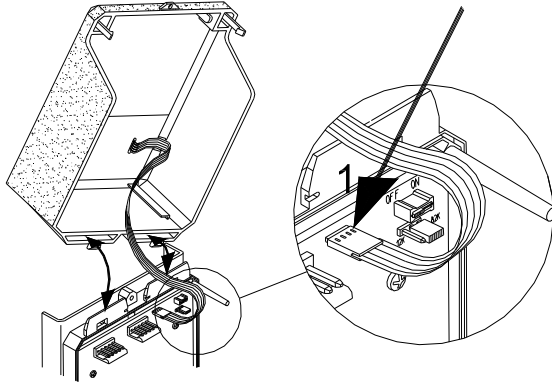

Fig. 1: Opening the housing cover  
Connecting the keypad

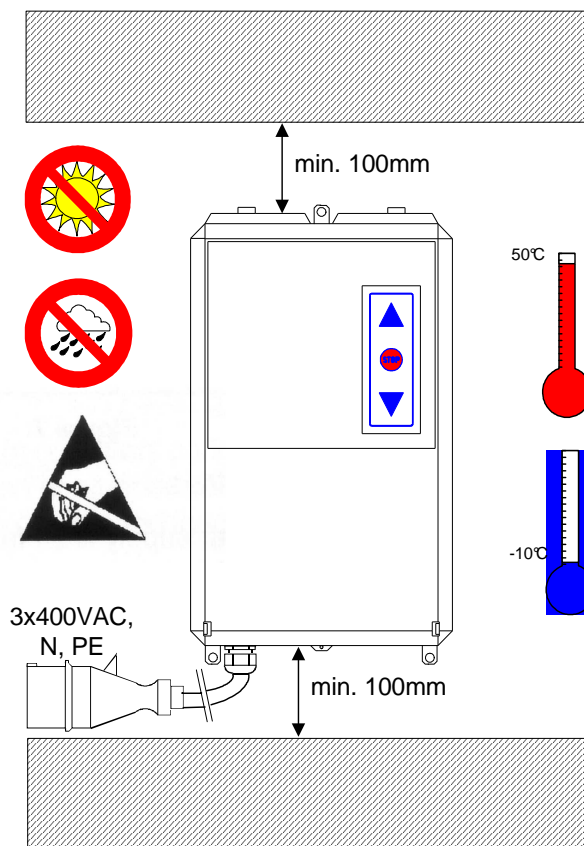

Fig. 2: Installing the controller

#### **⚠ ATTENTION**

- Before installing, check the controller for any transport or other damage. Damage inside the controller may under some conditions result in significant following damage to the controller including hazards to the user.
- Do not touch any electronic parts, especially parts of the processor circuit. Electronic components can be damaged or destroyed by electrostatic discharge.
- Before opening the housing cover, be sure that no drilling chips on the cover can fall into the housing.
- You have to make sure that the housing is installed without tension.
- Not used cable entries must be closed in order to get IP54.
- The cable entries are not allowed to have mech. stress.

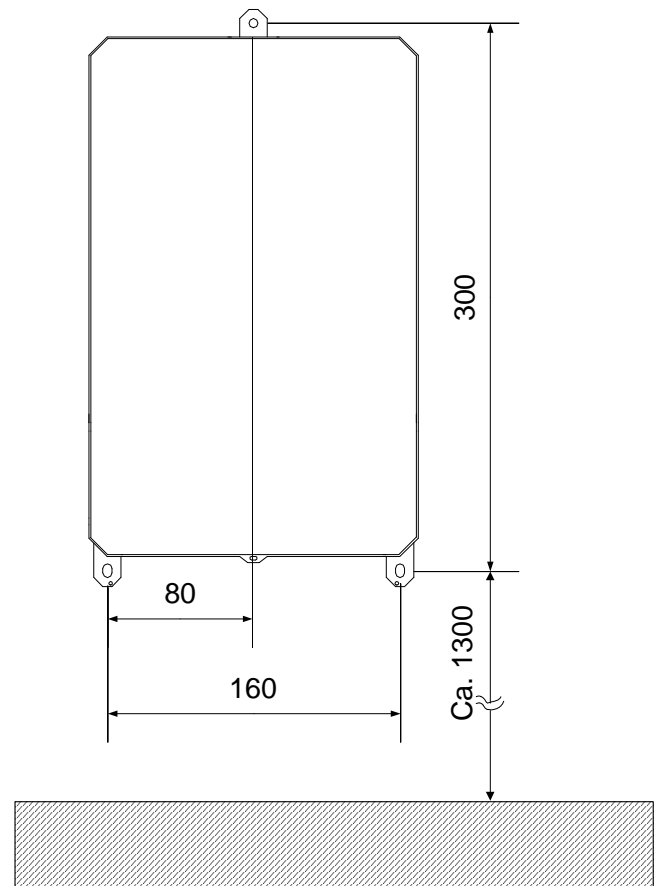

Fig. 3: Hole pattern

## 4 Electrical Connection

### **! WARNING**

- Wiring, testing and maintenance work on an open controller may be performed only without power. Observe in particular the points listed under Safety Advisories.
- After turning off the controller, dangerous voltage levels remain present for up to 5 minutes.
- Touching electronic components is dangerous due to residual voltages.
- Never operate the controller while the cover is removed.

### **! ATTENTION**

- Before turning on the controller for the first time and after finishing the wiring, check whether all motor connections are tight on the controller and motor side and whether the motor is correctly wired in star or delta configuration. Loose motor connections will often damage the converter.
- All controller voltage inputs are galvanically isolated from the supply by means of base isolation. All components connected to the controller must have additional isolation with a rated voltage of > 230 V (as per EN 60335-1).

- To maintain the EMC Directives, only shielded, separate motor lines may be used, with the shield connected on both ends (motor and controller side) and no additional connections in the line. Maximum cable length: 30 m.
- Fast running sectional doors may create very high electrostatic discharge levels. The discharging of this voltage may damage the controller. Therefore suitable measures must be taken to prevent electrostatic discharge.
- Maximum connection diameters of the printed card terminals used

	single wire (rigid)	fine wire (with/without wire end ferrule)
screw terminals	2,5	1,5
plug in terminals	1,5	1,0
motor terminals	2,5	2,5
line supply	2,5	1,5

### 4.1 Connecting the supply voltage

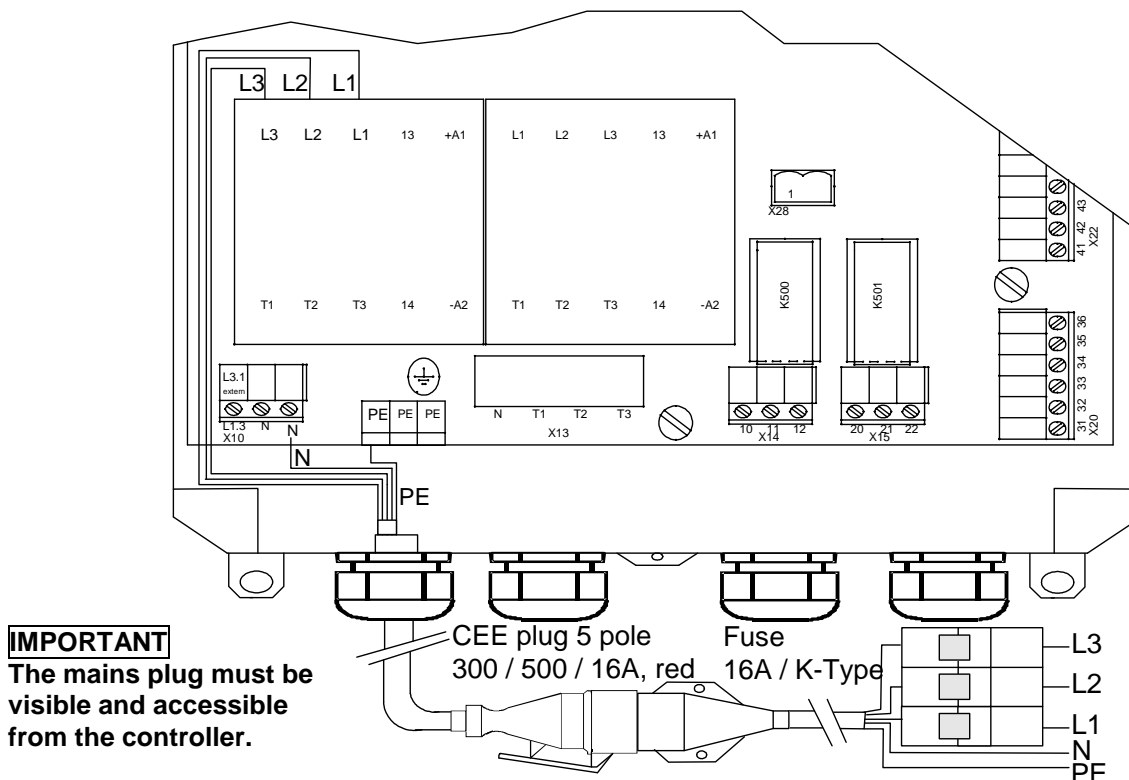

Fig. 4: Connecting the mains cable

## 4.2 Motor connections

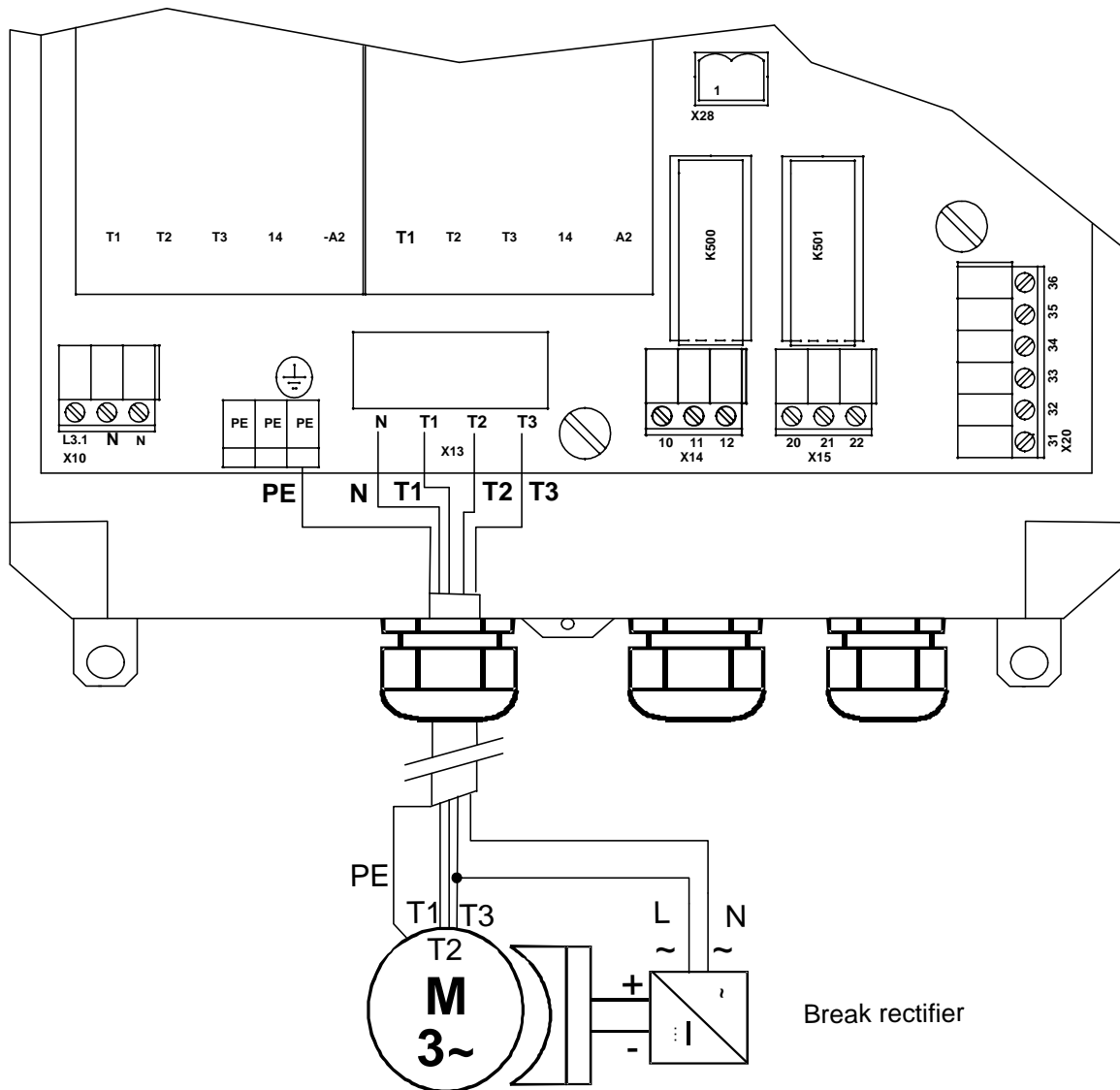

Fig. 5: Motor connections

## 4.3 Connecting the safety edge

Various types of safety edges can be connected, for example:

- Electrical safety edge with 1.2k $\Omega$  or 8.2k $\Omega$  terminating resistor.
- Dynamic optical systems.

If one of these safety edges is connected when the TST WU door controller is turned on, the edge is automatically detected.

**IMPORTANT** If no safety edge is connected, automatic closing of the door is not possible.

Use of other safety edge types is possible. Please contact the door manufacturer.

## 4.4 Connecting limit switches

Three various limit switch systems can be used with the TST WU door controller. In the standard setting an absolute encoder is used as the limit switch. In addition, mechanical cam limit switches or incremental encoders may be used.

### 4.4.1 Absolute encoder

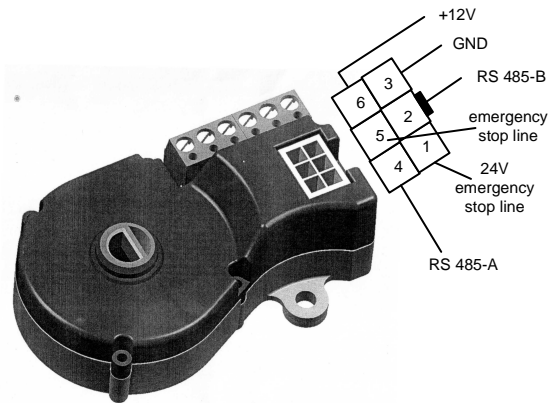

Fig. 6: Absolute encoder

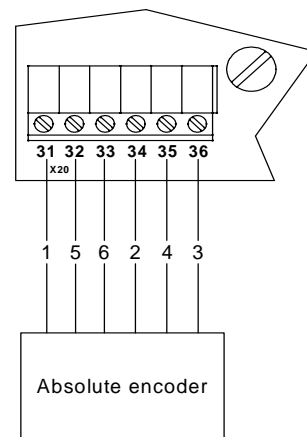

Fig. 7: Connecting the absolute encoder

### 4.4.2 Mechanical limit switches

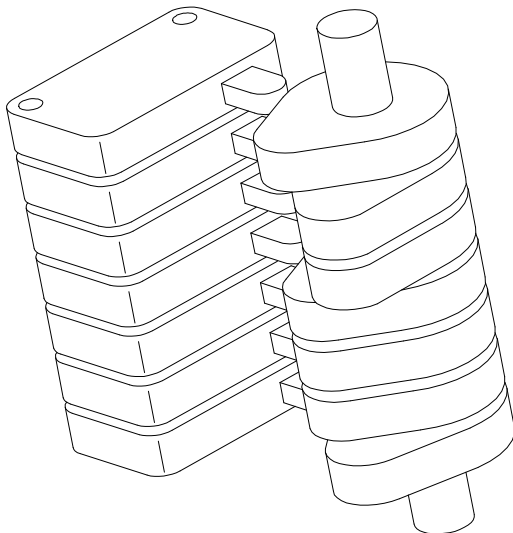

Fig. 8: Cam switch

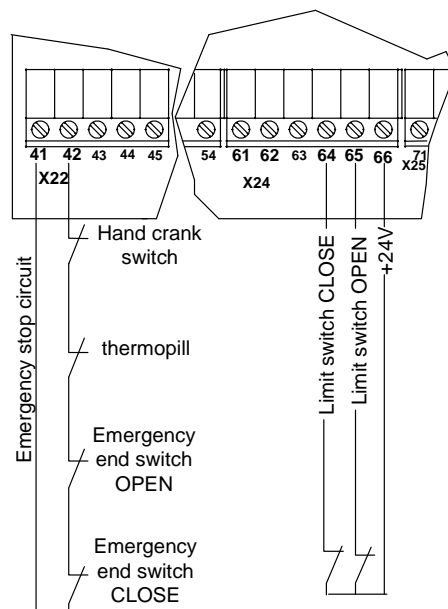









Fig. 9: Connecting cam switches

## 5 General instructions for parameterizing







### Opening parameterizing mode

1.	 Turn off door controller	Completely turn off power (see safety advisories)	7-segment display goes off after several seconds	
2.	 Turn DIP switch ON	Service mode is activated and controller cabinet closed.		
3.	 Turn on door controller	Turn on door controller	If service mode is activated, leading decimal point flashes Display message varies according to controller status	. * . . .
4.	 STOP (permanent)	Press Stop key and hold down	Waiting messages are displayed, e.g.:	E. 2 0 1
5.	 Open (permanent)	Press and hold down On key in addition	After approx. 2 sec. wait: In parameterizing mode	P. 0 0 0

### Parameter selection with parameterizing mode open

 OPEN or  CLOSE	Select desired parameter <b>CAUTION:</b> Not all parameters are directly accessible or modifiable, depends on password and positioning type set	The parameter value can be viewed or modified (see below). Display message varies with selection	P. . . .
---	---	--	----------

### Parameter editing for selected parameter

1.		Controller in parameterizing mode	Display of the desired parameter	P. 0 1 0
2.	 STOP (short)	Opening the parameter	The current parameter value is displayed	5
3.	 Open	Open-key for increasing parameter value	If the current valid parameter value is displayed, the decimal points will flash	6*
or	 Close	Close-key for decreasing the parameter value		4*
4.	 STOP (long)	Save new parameter value	The parameters is considered as saved if no decimal points flash	6
or	 STOP (short)	Cancel new parameter value	Cancel, the original parameter value is displayed again	4
5.	 STOP (short)	Change to displaying the parameter name	Displays parameter name	P. 0 1 0

### Exiting parameter mode

 STOP (long)	Immediately exits parameterizing mode, door operation is restored	The last saved value is automatically retained	
---	---	--	--

### Resetting the controller

P R E S S  +  +  simultaneously and hold down for approx. 3 sec.

#### IMPORTANT

After approx. 1h service mode is automatically reset. To reopen service mode, DIP switch must be momentarily switched to OFF with the controller turned off and then turned ON again, or perform a reset.

---

## 6 Basic Settings

---

To set the TST WU door controller into service, please follow the steps below.

---

### 6.1 Automatic querying of the basic data

---

If the TST WU door controller has not been preconfigured by the door manufacturer, the following parameters are automatically queried:

**IMPORTANT** For the TST WU door controller to automatically query the parameters, DIP switch S300 must be turned on (S300 location see Fig. 10: Location S300).

 If DIP switch S300 is not turned on and the basic parameters not set, error code F.090 is displayed..

 A „-1“ in the display is used by the controller as an indication that querying of this parameter is being forced.

- **Positioning system P.205**

The limit switch system in use must be set using Parameter P.205.

P.205: 0 = Mechanical limit switches Version 1

P.205: 1 = Reserverd

P.205: 2 = Incremental encoder as limit switch

P.205: 3 = Absolute encoder

- **Reference switch profile P.25F**

If an incremental encoder is used as a limit switch, you must use Parameter P.25F to define a reference switch type and the behavior of the controller after power-up.

P.25F: 0 = The lower end position must be moved to and saved.

P.25F: 1 = After power-up the system automatically synchronizes to a lower reference switch.

P.25F: 2 = After power-up the system automatically synchronizes to the safety edge.



P.25F: 3 = After power-up the system automatically synchronizes to an upper reference switch.

P.25F: 4 = After power-up the system automatically synchronizes to an upper mechanical stop.

P.25F: 5 = After power-up the system automatically synchronizes to the safety edge and then to an upper mechanical stop.

P.25F: 6 = After power-up the system automatically synchronizes to the safety edge and then to an upper reference switch.



P.25F: 7 = After power-up the system automatically synchronizes to an upper reference switch and then to an upper mechanical stop.

 Automatic querying of the basic data can be cancelled by pressing the  OPEN key while the controller is being turned ON. This takes you directly to the parameterizing level.

## 6.2 Changing parameters

 Changing the basic data is not necessary if they were previously automatically queried and set.

To modify the preset parameters, proceed as follows:

- Disconnect the mains plug
- Set the S300 DIP switch to on.
- Connect the mains plug.
- Press  STOP and  OPEN at the same time for approx. 3 sec. to open parameterizing mode for the door controller.
- Change the desired parameter.
- After making your settings, exit parameterizing mode by pressing the  STOP key for approx. 3 sec.

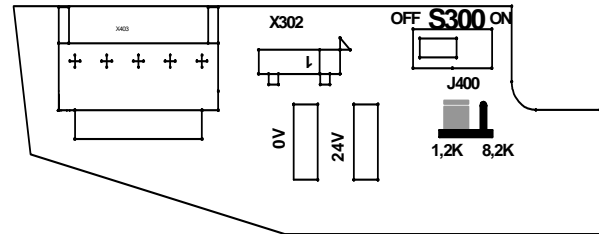

Fig. 10: Location S300





## 7 Startup...

### WARNING

Before you start up the controller you have to check the electrical connections and the correct position of the plug in cards.

After the start up you must check all the safety devices and their functions.

### 7.1 ... using absolute or incremental encoders

1. Open CALIBRATE mode by briefly pressing the  STOP key.
2. Go to Door-CLOSE position by pressing the  CLOSE key and save by pressing the  STOP-key for approx. 3 sec.
3. Go to Door-OPEN position by pressing the  OPEN key and save by pressing the  STOP-key for approx. 3 sec.

 When the door then moves in automatic mode, the limit switch bands are automatically set.

---

## 7.2 ... using mechanical limit switches

---

1. Press  $\nabla$  CLOSE-key to bring door to approx. 10cm from the closed position.

**IMPORTANT** The distance depends greatly on the door type and the speed; increase this value for fast moving doors.

If the door moves in the wrong direction: wrong motor rotary field, turn off controller and reverse the 2 motor wires.

2. Set lower limit switch so that it just trips

**IMPORTANT** Do not travel past the limit switch in the end positions!

3. Press  $\blacktriangle$  OPEN-key to bring door to approx. 10cm from the opened position.

**IMPORTANT** The distance depends greatly on the door type and the speed; increase this value for fast moving doors.

4. Set upper limit switch so that it just trips

**IMPORTANT** Do not travel past the limit switch in the end positions!

5. If necessitated by door type: set upper and lower EMERGENCY limit switches  
*Connect normally closed contacts, e.g., in the safety circuit, in series with thermopile detector.*

6. Press  $\text{STOP}$  STOP and  $\blacktriangle$  OPEN to enter parameterizing mode and select Parameter P.980 „Service Mode“, open and set parameter value „2“ to „0“ (Automatic mode).

7. Correct limit switch positions for Door OPEN and Door CLOSE as needed by fine adjustment of the end positions in automatic mode.

**WARNING** To prevent unintended moving of the door, adjust the limit switches only when the Emergency-STOP is activated or with the controller turned off !

8. The door may now be operated in Automatic mode.

---

## 7.3 New request for teaching end positions

---

If the end positions have been pre-taught (using electronic limit switches) but these are not appropriate for the door in question, teaching the end positions can be newly requested.

Here the following parameter must be set:

P.210: 5 = New teaching of all end positions

## 8 Additional connection possibilities

### 8.1 Photo eye

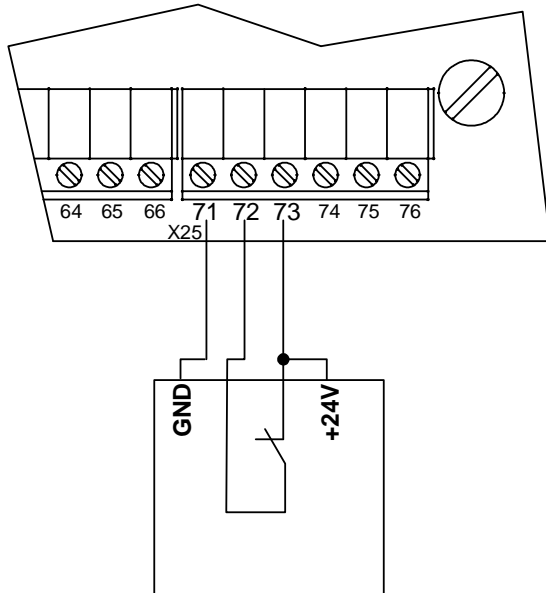

Fig. 11: Photo eye connection

### 8.2 External triggering devices

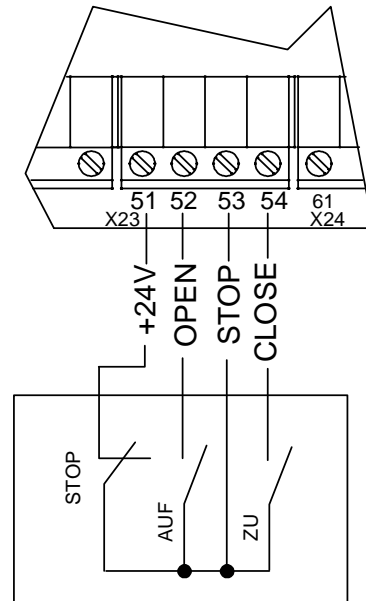
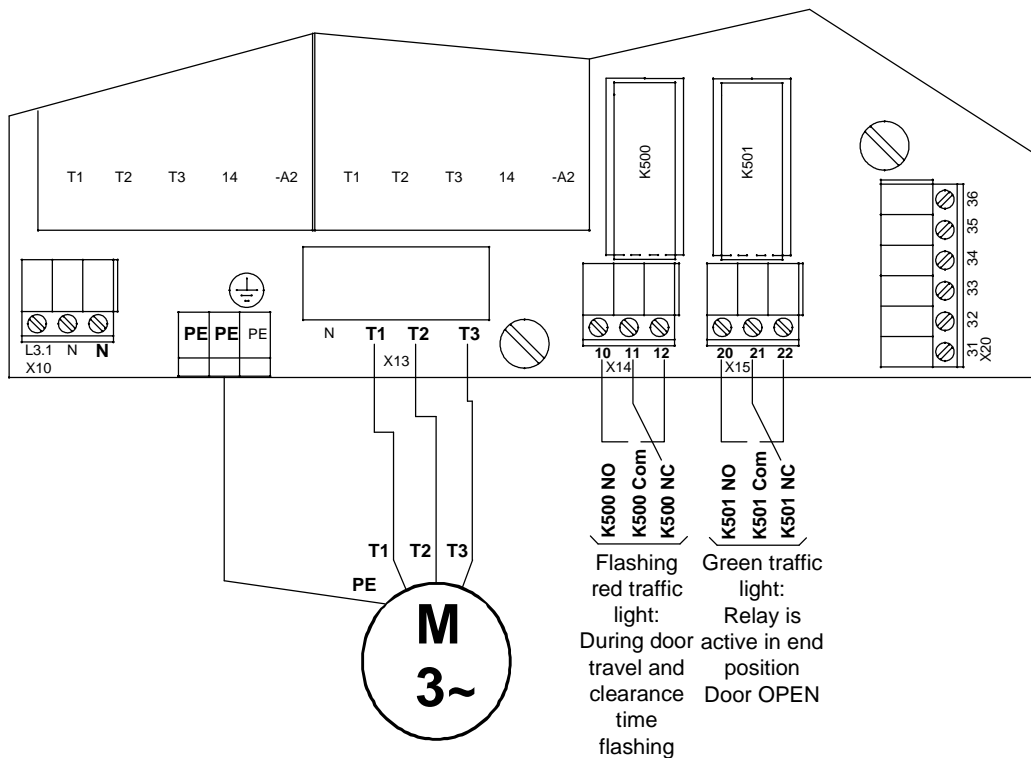

Fig. 12: External triggering devices

## 9 Overview of outputs



## 10 Functions

P.	[Unit] Range	Door Functions	Default
<b>000</b>	[Cycles]	Door cycle counter display Display: 1234567 ⇒ 1234. ▼-key .567 Display: 67 ⇒ 67	
<b>005</b>	[Cycles]	Displays number of door cycles until maintenance is required. Display: 1234567 ⇒ 1234. ▼-key .567 Display: 67 ⇒ 67	
<b>010</b>	[s] 0..200	Open hold time 1 (End position Upper - Eo) 0: Automatic closing deactivated	10
<b>011</b>	[s] 0..200	Open hold time 2 (Intermediate hold position - E1) 0 = turned off	10

P.	[Unit] Range	Selecting the limit switch system	Default
<b>205</b>	0..4	Selecting the positioning system: 0. Limit switch 1 (limit switch as normally closed, pre-limit switch normally open) 1. Limit switch 2 (limit switch and pre-limit switch normally closed) 2. Incremental encoder (reference switch in lower end position) 3. Absolute encoder (9600 baud)	-1

P.	[Unit] Range	Teaching the end positions with electronic limit switches	Default
<b>210</b>	0..5	Selecting the position calibrated by a deadman move ("teach in"): 0: no → None/Cancel 1: Eu → Lower and Upper limit switch (intermediate stop: see P244) 2: Eo → Upper limit switch (intermediate stop: see P244) 3: uo → Upper and Lower limit switch 4: E1 → Intermediate stop limit switch (P244 is ignored) 5: al → (all) Lower, Upper and Intermediate Stop limit switch (per P244)	0

P.	[Unit] Range	Reference switch profile	Default
<b>25F</b>	0..7	0: The lower end position must be positioned at in deadman mode and saved. 1: After power-up the system automatically synchronizes to a Lower reference switch. 2: After power-up the system automatically synchronizes to the safety edge. 3: After power-up the system automatically synchronizes to an Upper reference switch. 4: After power-up the system automatically synchronizes to an Upper mechanical stop. 5: After power-up the system automatically synchronizes to the safety edge and then to an Upper mechanical stop. 6: After power-up the system automatically synchronizes to the safety edge and then to an Upper reference switch. 7: After power-up the system automatically synchronizes to an upper reference switch and then to the Upper mechanical stop.	-1

P.	[Unit] Range	Diagnostics	Default
<b>910</b>	0..15	Selecting display mode (request by STOP button or during motor movement) 0: Controller sequence (Automatic mode) 1: Reserved 2: Reserved 3: Reserved 4: Reserved 5: Reserved 6: Reserved 7: Reserved 8: last measured run time (1/10 to 99.9s, 1/1 starting at 100s) For electronic limit switches only: 9: [Inc] current position progress 10:[Inc] current reference position 11:[dig] current channel 1 value of absolute encoder 12:[dig] current channel 2 value of absolute encoder 13:reserved 14:reserved 15:reserved	0
<b>920</b>	Eb 1 Eb 2 Eb 3 Eb 4 Ebcl Eb -	Display error memory / Faults ⇒ Open by pressing Stop key again, ⇒ Change by pressing Open/Close key ⇒ Quit by pressing Stop key. ⇒ Exit using cancel "EB-". • Eb 1 → Error messages 1 (most current) or Er-- • Eb 2 → Error message 2 or Er-- • Eb 3 → Error message 3 or Er-- • Eb 4 → Error message 4 or Er-- • Ebcl → Clear entire error memory • Eb - → Cancel (Display noEr: no error)	Eb 1
<b>925</b>		Software version display	
<b>930</b>	[s] 0..120.0	Motor run-time during last door move	
<b>940</b>	[V]	Line supply voltage display	

P.	[Unit] Range	Service Modes	Default
<b>973</b>	0..1	Reset service counter: Reset (1) / Cancel (0)	0
<b>980</b>	0..2	Service mode 0: Automatic (open and close in hold function) 1: Deadman Close (manual mode close / automatic mode open) 2: Deadman (manual mode for open and close) 3: Emergency (deadman open and close, all errors and securities are ignored).	0
<b>999</b>	0..FFFF	Password entry	1

## 11 Message Overview

Improper end positions		
<b>F.000</b>	Door position too far up	Too small a parameter value for upper emergency limit switch Upper limit switch range (limit switch band) too small Mechanical brake defective or improperly set
<b>F.005</b>	Door position too far down	Too small a parameter value for lower emergency limit switch Lower limit switch range (limit switch band) too small Mechanical brake defective or improperly set

Implausibilities in door movement		
<b>F.020</b>	Run time exceeded (during opening, closing or deadman)	current motor run time has exceeded set maximum run time, door may be sticking or is blocked If using mechanical limit switches, one may not have tripped
<b>F.030</b>	Lag error (position change of the door is less than expected)	Door or motor is blocked Too little power for lift torque Too little speed Mechanical limit switch was not left or is defective Absolute or incremental encoder not tightened sufficiently in its mounting Wrong positioning system selected ( <b>P.205</b> )
<b>F.031</b>	Detected rotational direction deviates from expected	When using incremental encoders: Channel A and B reversed Motor rotation direction reversed compared with calibration setting Too much „pancaking“ when starting, brake releases too soon, or too little torque, adjust boost as necessary.
<b>F.043</b>	Pre-limit switch fault (light barrier)	The pre-limit switch for the light barrier remains activated even in the middle end position or upper end position.

Error messages for incremental encoder		
<b>F.050</b>	Reference switch position deviates from permissible range. During cyclical synchronization	Reference switch constantly tripped (defective) Reference switch trips too far from the selected reference. Reference switch trips in the limit switch band P270 and P280 are both at the reference switch
<b>F.051</b>	Reference switch position deviates from permissible range.	Reference switch lies in the limit switch band Reference switch is beyond 15% EO Reference switch defective
<b>F.052</b>	Reference switch not recognized	The reference switch is not recognized within 20% EO during automatic synchronization after power-on The reference switch is not recognized in the associated end position.

Maintenance counter exceeded		
<b>F.080</b>	Fault: Maintenance is required	Service counter has expired

Parameters not set		
<b>F.090</b>	Controller not parameterized	The basic parameters (P.205, P.100 to P.103) for the TST WU controller have not yet been set.

Safety chain faults		
<b>F.201</b>	Internal E-Stop „push-button“ tripped  or Watchdog (computer monitor)	E-Stop chain was interrupted starting at input „internal E-Stop“ without parameterizing mode having been selected Internal parameter or EEPROM checks defective, pressing the STOP key provides additional information about the cause
<b>F.211</b>	External E-Stop 1 tripped	E-Stop chain was interrupted starting at Input 1 (terminals 1 and 2)
<b>F.212</b>	External E-Stop 2 tripped	E-Stop chain was interrupted starting at Input 2 (terminals 3 and 4)

Faults in the safety chain		
<b>F.360</b>	Short circuit detected on edge input	Short circuit detected on edges with normally closed contact
<b>F.361</b>	Number of edge trips for closing has reached set limit	Parameterized, maximum number of safety edge trips during a door cycle was exceeded
<b>F.363</b>	Interruption on edge input	Connection cable defective or not connected Termination resistor incorrect or missing Jumper J600 incorrectly set
<b>F.364</b>	Safety edge testing failed	Safety edge was not activated as expected when requesting a test. The time between request for testing and actual testing not in agreement
<b>F.366</b>	Too high a pulse frequency for optical safety edge	Defective optical safety edge Defective input for internal safety edge
<b>F.369</b>	Internal safety edge incorrectly parameterized	An internal safety edge is connected but deactivated
<b>F.373</b>		
<b>F.374</b>	Safety bar testing failed	Pre-limit switch for safety edge incorrectly set or defective Processing module defective Safety edge defective
<b>F.379</b>		
<b>F.385</b>	Fault in pre-limit switch for safety edge	Pre-limit switch for turning off the safety edge or reversing after safety edge tripping remains tripped even in the upper end position.

General hardware faults		
<b>F.400</b>	Controller hardware reset detected	<ul style="list-style-type: none"> <li>Excessive noise on supply voltage</li> <li>Internal watchdog tripped</li> <li>RAM error</li> </ul>
Positioning system faults		
<b>F.700</b>	Position sensing defective	<p><b>For mechanical limit switches:</b></p> <ul style="list-style-type: none"> <li>At least one limit switch does not correspond to the configured active status.</li> <li>An implausible combination of at least 2 active limit switches</li> </ul> <p><b>For electronic limit switches:</b></p> <ul style="list-style-type: none"> <li>After invoking activation of the factory parameters (Parameter <b>P.990</b>) the corresponding positioning system was not parameterized.</li> <li>Calibration not completed or is incorrect and must be repeated.</li> <li>When activating the intermediate stop the intermediate stop is implausible.</li> <li>Synchronization not finished or reference switch defective.</li> </ul>
<b>F.720</b>	Synchronization error in position sensing with incremental encoder	<ul style="list-style-type: none"> <li>Intermediate stop position is less than the minimum incremental value (25).</li> <li>Synchronization was not finished.</li> <li>The selected reference switch was not reached or is outside its tolerance</li> <li>The incremental encoder is not counting or the door is blocked (also F.030, lag error)</li> <li>Incremental inputs IN 9 and IN 10 are reversed (also F.031 rotation error)</li> </ul>
<b>F.750</b>	Protocol Transmission error	<ul style="list-style-type: none"> <li>Defective hardware or electrically noisy environment</li> </ul>
<b>F.751</b>	Synchronization FU <-> absolute encoder	<ul style="list-style-type: none"> <li>Defective hardware or electrically noisy environment</li> <li>Absolute encoder processor electronics defective</li> </ul>
<b>F.752</b>	Timeout with protocol transmission	<ul style="list-style-type: none"> <li>Interface cable defective / interrupted</li> <li>Absolute encoder processor electronics defective</li> <li>Defective hardware or electrically noisy environment</li> </ul>
<b>F.760</b>	Position outside of window	<ul style="list-style-type: none"> <li>Position encoder drive defective</li> <li>Absolute encoder processing electronics defective</li> <li>Defective hardware or electrically noisy environment</li> </ul>
<b>F.761</b>	Distance Channel 1 <-> Channel 2 outside allowed window	<ul style="list-style-type: none"> <li>Position encoder drive defective</li> <li>Defective hardware or electrically noisy environment</li> </ul>
<b>F.762</b>	Electronic limit switch positions incorrect	<ul style="list-style-type: none"> <li>Upper limit switch Eo or intermediate limit switch E1 has exceeded the valid limit range</li> <li>Controller not yet initialized</li> <li>Position values during calibration not correct or values are no longer plausible</li> </ul>

User Call Crash-System		
<b>F.060</b>	Control panel was just powered on or bottom rail profile was crashed out of the side guides	See reset-procedure in <ul style="list-style-type: none"> <li>Installation manual-</li> <li>Schematic</li> <li>Panel door</li> </ul>

### 11.1 Internal system-related errors F.9xx

These are internal errors which cannot be eliminated by the user.  
If such an error occurs, call customer service immediately.

## 11.2 Information messages

### General messages

<b>STOP</b>	<b>Stop</b> / Reset state, wait for next incoming command
<b>_Eu_</b>	<b>End position Lower Eu</b>
<b>≡Eu≡</b>	<b>End position Lower locked</b> → no raising possible (e.g., lock-door)
<b>ZUF ☐</b>	<b>Closing active</b>
<b>˘Eo˘</b>	<b>End position Upper Eo</b>
<b>≡Eo≡</b>	<b>End position Upper locked</b> → no closing possible (e.g., safety edge)
<b>☐AUF</b>	<b>Opening active</b>
<b>-E1-</b>	<b>End position middle E1 (intermediate stop position)</b>
<b>≡E1≡</b>	<b>End position middle locked</b> → no closing possible (e.g., safety edge)
<b>FAIL</b>	<b>Fault</b> → only deadman travel is possible, possibly automatic opening
<b>EICH</b>	<b>Calibration</b> → Setting the end positions in deadman travel (for absolute encoder) → Start procedure using STOP key
<b>≡NA≡</b>	<b>E-Stop</b> → No travel possible, hardware safety chain interrupted
<b>NOTF</b>	<b>E-travel</b> → Deadman travel without taking into account safeties, etc.
<b>'Hd'</b>	<b>Manual</b> → Deadman mode
<b>ParA</b>	<b>Parameterizing</b>
<b>SYNC</b>	<b>Synchronization</b> (incremental encoder / limit switch → Pos.unknown)
<b>'Au'</b>	<b>Automatic</b> → indicates change from „Manual“ to „Automatic“ status
<b>'Hc'</b>	<b>Semi-automatic</b> → indicates change from „Manual“ to „Semi-automatic“
<b>WU</b>	Initial display after power up ( <b>Power Up and self-test</b> )

### Status messages during calibration

<b>E.i.E.u.</b>	Calibration of the End position Lower requested (in deadman travel)
<b>E.i.E.o.</b>	Calibration of the End position Upper requested (in deadman travel)
<b>E.i.E.1.</b>	Calibration of the intermediate position E1 (in deadman travel)

### Status messages during synchronization

<b>S.y.E.u.</b>	Synchronization of End position Lower requested (Deadman or wait for start condition)
<b>S.y.E.o.</b>	Synchronization of End position Upper requested (Deadman or wait for start condition)
<b>S.y.E.1.</b>	Synchronization of intermediate stop position E1 (in deadman)
<b>S.y.op</b>	Automatic open until mechanical stop, then automatic synchronization of End position Upper
<b>S.y.cL</b>	Automatic close taking into account safeties until mechanical stop, then automatic synchronization of End position Lower
<b>S.y.c≡</b>	Automatic close is locked due to request A

### Status messages during deadman

<b>Hd.cL</b>	Deadman close (membrane key: CLOSE)
<b>Hd.oP</b>	Deadman open (membrane key: OPEN)
<b>Hd.Eu</b>	End position Lower reached, no further deadman close possible
<b>Hd.Eo</b>	End position Upper reached, no further deadman open possible
<b>Hd.Ao</b>	Outside of permitted Eo position (no deadman open possible)

### Information messages during Automatic mode

<b>I.080</b>	Maintenance required soon / service counter nearly expired
<b>I.100</b>	Speed when reaching upper end position too high
<b>I.150</b>	Speed when reaching lower end position too high
<b>I.160</b>	Continuous CLOSED still active
<b>I.170</b>	Forced opening being performed
<b>I.199</b>	Door cycle not plausible (re-initialize → Parameters)
<b>I.200</b>	Reference position corrected or recognized (after calibration)
<b>I.201</b>	Reference position re-initialized
<b>I.202</b>	Reference position missing
<b>I.203</b>	Reference position incorrect

<b>I.205</b>	Synchronization
<b>I.210</b>	Pre-limit switch Upper not plausible
<b>I.211</b>	Pre-limit switch Lower not possible
<b>I.310</b>	Open-command on Door2 being issued
<b>I.500</b>	Correction of upper limit switch running
<b>I.501</b>	Upper pre-limit switch corrected
<b>I.502</b>	Upper limit switch band corrected
<b>I.505</b>	Correction of lower limit switch running
<b>I.506</b>	Lower pre-limit switch corrected
<b>I.507</b>	Lower limit switch band corrected
<b>I.510</b>	Limit switch correction finished
<b>I.515</b>	Controller is preparing automatic teach-in of the limit switches
<b>I.555</b>	Limit switches being corrected

#### Information messages while parameterizing

<b>noEr</b>	Error memory: no error saved
<b>Er--</b>	Error memory: if error but no associated message found
<b>Prog</b>	Programming message while carrying out original parameter or default set

#### General inputs

<b>E.000</b>	OPEN key on membrane keypad
<b>E.050</b>	STOP key on membrane keypad
<b>E.090</b>	CLOSE key on membrane keypad
<b>E.101</b>	Start impulse open
<b>E.102</b>	Start impulse close
<b>E.103</b>	Impulse mode
<b>E.104</b>	p.e.c. 2 (option)
<b>E.105</b>	STOP impulse
<b>E.106</b>	Intermediate Stop; V5030SE/V6030SE : RESET
<b>E.107</b>	Interlock in EU
<b>E.108</b>	p.e.c.1
<b>E.109</b>	Reserve
<b>E.110</b>	Anti-Crash input (option)
<b>E.111</b>	Reserve
<b>E.118</b>	Reserve

#### Safety/Emergency stop chain

<b>E.201</b>	Internal E-Stop „pushbutton“ tripped
<b>E.211</b>	External E-Stop 1 tripped
<b>E.212</b>	External E-Stop 2 tripped

#### Safety edge, general

<b>E.360</b>	Activation of internal safety edge
<b>E.363</b>	Fault in internal safety edge
<b>E.370</b>	Activation of external safety edge
<b>E.373</b>	Fault in external safety edge
<b>E.379</b>	External safety edge activated but not yet plugged in

#### RC plug-in module

<b>E.401</b>	RC Channel 1
<b>E.402</b>	RC Channel 2

#### Induction loop processor plug-in module

<b>E.501</b>	Detector Channel 1
<b>E.502</b>	Detector Channel 2

#### Internal inputs

<b>E.900</b>	Controller chip fault signal
--------------	------------------------------