

TDOKU0000010-EN / 12.2025

EN

Instructions for fitting, operating and maintenance

Rolling shutter TD

Table of contents

1	About these instructions	2
1.1	Intended use.....	2
1.2	Standards and directives to be observed	2
1.3	Warning labels used	3
1.4	Symbols used.....	3
1.5	Abbreviations used.....	3
2	Basic Safety Instructions	4
2.1	Transport	4
2.2	Fitting, testing and maintenance	4
2.3	Operation.....	4
3	Warranty	4
4	Assembly	4
4.1	Testing prior to fitting the door	5
4.2	Fitting dimensions	6
4.3	Fitting steps.....	6
4.4	Control system and control elements.....	41
4.5	Suspended ceilings or obstacles in the lintel area	41
5	Control B100 R	41
5.1	Setting additional functions via DIL switches....	41
5.2	Funk.....	42
6	Initial start-up	43
6.1	End-of-travel positions	43
6.2	Test run	43
7	Operation	43
7.1	Safety instructions for door operation.....	43
7.2	Emergency stop.....	44
7.3	Emergency operation in case of operator malfunction.....	44
7.4	Operating conditions.....	44
7.5	Wind load	44
7.6	Information on the product characteristics	45
7.7	Accessories	45
8	Inspection and maintenance	45
8.1	Obligation to inspect and maintain.....	45
8.2	Malfunctions and damage remedy.....	45
8.3	Original spare parts	45
8.4	Wearing parts	45
8.5	Operator power	45
8.6	Wired closing edge safety device (SKS).....	45
8.7	Accessories	46
8.8	Inspection and maintenance plan	46
9	Cleaning and care	47
9.1	Door curtain.....	47
10	Extension and conversion	47
11	Dismantling	47
12	Excerpt from the Declaration of Incorporation.	47
13	LED display on keypad	48
14	Technical data	48

1 About these instructions

Dear Customer,

We are delighted that you have decided to choose a Hörmann product.

These instructions are original operating instructions as outlined in EC Directive 2006/42/EC. Read and follow these instructions carefully, paying particular attention to section 2 Basic Safety Instructions on page 4. They provide you with important information on the safe fitting and operation, as well as proper care and maintenance, of your door system.

Competent operation and proper maintenance influence the performance and availability of your door system to a considerable degree. Operating errors and inadequate maintenance will lead to avoidable failures. Only competent operation and proper maintenance will guarantee satisfactory, long-term operational safety.

Should you have any questions on having read through these instructions, please feel free to consult our Customer Service.

1.1 Intended use

The TD rolling shutter is only suitable for the following applications:

- Operation in industrial and commercial applications
- Closing passage openings
- Pedestrian and goods traffic
- Closing openings with a vertically guided door leaf

Use for purposes other than or exceeding those stated above is prohibited.

1.2 Standards and directives to be observed

1.2.1 Fitting and maintenance

At the least, observe the following European standards and directives, as well as all country-specific safety regulations, standards and provisions:

305/2011	Construction Products Regulation
2006/42/EC	Machinery Directive
2014/35/EU	Low Voltage Directive
2014/30/EU	Electromagnetic compatibility
EN 12453	Industrial, commercial and garage doors and gates – Safety in use of power operated doors – Requirements and test methods
EN 12635	Industrial, commercial and garage doors and gates – Installation and use
EN 13241	Industrial, commercial, garage doors and gates – Product standard, performance characteristics
EN ISO 13849-1 PL “c”, Cat. 2	Safety of machinery – Safety-related parts of control systems
EN 60335-1	Safety of household and similar electrical appliances
DIN 4109-1	Sound insulation in buildings

For safety and health at work, observe at least the following rules and regulations or comparable national regulations, e.g.:

ASR A1.7	Power-Operated Windows and Doors
DGUV V3	General Regulations – Electrical Installations and Equipment

1.2.2 Operation





At the least, observe the following European standards, as well as country-specific safety regulations, standards and provisions:

EN 12453	Industrial, commercial and garage doors and gates – Safety in use of power operated doors – Requirements and test methods
----------	---



For safety and health at work, observe at least the following rules and regulations or comparable national regulations, e.g.:













ASR A1.7	Power-Operated Windows and Doors
DGUV V3	General Regulations – Electrical Installations and Equipment

1.3 Warning labels used

ATTENTION	Indicates a danger that can lead to damage or destruction of the product .
	The general warning symbol indicates a danger that can lead to injury or death . In the text, the general warning symbol will be used in connection with the caution levels described below. In the illustrated Section, an additional instruction refers back to the explanation in the text.
 CAUTION	Indicates a danger that can lead to minor or moderate injuries.
 WARNING	Indicates a danger that can lead to death or serious injuries.
 DANGER	Indicates a danger that immediately leads to death or serious injuries.

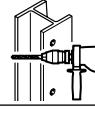
1.4 Symbols used

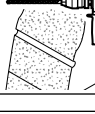
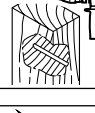
-  Important note for avoiding damage to property
-  Correct arrangement or activity
-  Incorrect arrangement or activity

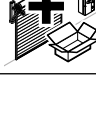
-  See text section
-  See illustrated section
-  See fitting dimension sheet
-  See separate fitting instructions for the control or for the additional electrical control elements
-  Fitting behind or in front of the opening
-  Fitting in the opening
-  Additional posts marked in the table of fitting dimensions
-  Welding on steel
-  Drilling in steel
-  Drilling in concrete
-  Drilling in brickwork
-  Drilling in timber
-  Remove and dispose of component or packaging
-  Check
-  Optional components

1.5 Abbreviations used

EN	European standard
----	-------------------

OFF	Finished floor level (FFL)
-----	----------------------------

Colour code for cables, single conductors and components							
BK	black	BU	Blue	RT	red	GE	Yellow
BN	Brown	GN	Green	WH	White		

2 Basic Safety Instructions

Keep these instructions safe at the place of use together with all the documentation for the door system.

 WARNING
<p>Incorrect fitting or incorrect handling</p> <p>Incorrect fitting or handling of the door could result in serious injury.</p> <p>► Follow all the instructions provided in this manual.</p>

2.1 Transport

ATTENTION
<p>Transporting the door barrel without a special pallet</p> <p>The door may be damaged if transported without a pallet.</p> <p>► The door barrel must only ever be transported on the special pallet.</p>

2.2 Fitting, testing and maintenance

Fitting, testing and maintenance may only be carried out by a specialist. According to EN 12635, a specialist is a person with suitable training, specialist knowledge and practical experience sufficient to correctly and safely fit, test, and carry out maintenance on a door system.

- For your own safety, have the product installed by an approved specialist company.
- Do not alter or remove any functional parts! You otherwise risk putting important safety components out of action.
- Always obtain the permission of the structural engineer before fastening the door system to supporting structural elements.
- Throughout fitting, protect the door system components, especially the door curtain, against dirt and damage.
- Make sure that whenever checks, maintenance work and cleaning are being carried out, the door system cannot be actuated by other persons.

 WARNING
<p>Changes to the door construction</p> <p>Additional components could overload the door construction and lead to serious injuries.</p> <p>► Do not attach any additional components.</p>

2.3 Operation

- The door system may only be operated by persons who have been instructed in its proper use. Instruction is provided by the fitting personnel following the initial start-up procedures.
- The door system may only be operated with push-button control elements using press-and-hold operation.
- The door system opens and closes vertically upwards and downwards. When operating the door, make sure that neither persons, children in particular, nor objects are located within the door's area of travel.

 WARNING
<p>Defective door systems</p> <p>A fault in the door system can lead to serious injuries.</p> <p>► Only ever use the door system when it is technically sound and in perfect working order.</p>

3 Warranty

For the warranty, the generally recognised terms and conditions or those agreed in the delivery contract apply. The warranty will no longer apply under the following conditions:

- You damage the door due to a lack of knowledge of the information provided in these Instructions for Fitting, Operating and Maintenance.
- You carry out structural modifications without our prior approval.
- You undertake improper installation or arrange for same to be carried out by others, contrary to the installation guidelines we have set out.
- You damage the door due to improper operation (see section 7 *Operation on page 43*).
- You are using the door for purposes for which it was not intended (see section 1.1 *Intended use on page 2*).
- You fail to have the door inspected and maintained at regular intervals as stipulated (see section 8.1 *Obligation to inspect and maintain on page 45*).

4 Assembly

NOTICES:

Refer to the following documents:

- Enclosed additional sheets for special components or special equipment as well as the table of fitting dimensions
- The fitting notes in section 2 *Basic Safety Instructions on page 4*.
- The regulations for fitting and workplace safety as described in section 1.2 *Standards and directives to be observed on page 2*.

The fitting of the operator and catch safety device is shown for the "operator side right" door version. The components are to be mounted reversed for the "operator side left" door version.

All specified dimensions in the illustrated section are in [mm].

4.1 Testing prior to fitting the door

4.1.1 Prerequisites for the building structure

Fit the door only if the following prerequisites are fulfilled:

- There is a second exit in the room where the door is to be fitted.
- A metre line is present.
- The hall floor is finished.
- The building structure is level (tolerance ± 5 mm).

4.1.2 Minimum requirements for the building structure

- Concrete
 - Strength class C 20/25
 - Thickness 140 mm
 - Standard EN 206-1
- Steel
 - Strength class S235-JRG2
 - Thickness 5 mm
 - Standard EN 10027-1
- Brickwork
 - Strength class 12 / mortar group II
 - Thickness 240 mm
 - Standard DIN 1053-1
- Timber
 - Coniferous wood C24 / quality category II
 - Thickness 120 mm
 - Standard DIN 1052 (EC5)

4.1.3 Test dimensions

p1	Clear width of the building opening
p2	Clear height of the building opening
p3	Min. sideroom for support bracket on left
p4	Min. sideroom for side guide on left
p5	Min. sideroom for support bracket on right
p6	Min. sideroom for side guide on right
p7	Min. headroom
p8	Min. fitting depth
p9	Bottom support bracket dimension on left
p10	Bottom support bracket dimension on right
p11	Ordering size: door width
p12	Ordering size: door height
p13	Available sideroom on left
p14	Available sideroom on right
p15	Available headroom

Curtain cover

pv0.00	Total width of curtain cover
pv0.01	Fitting depth of curtain cover
pv1.00	FFL to top edge of barrel casing support bracket
pv1.01	Centre of door to outer edge of curtain cover on operator side

pv1.02	Centre of door to outer edge of curtain cover on bearing side
pv1.03	Distance from outer edge of curtain cover to centre of centre support bracket or distance from centre of centre support bracket to centre of centre support bracket
pv1.04	FFL to bottom edge of operator cover

4.1.4 Door components

Check the following points before fitting:

- The delivery is complete.
- All the components are damage-free.

4.1.5 Fixing points

 WARNING
<p>Danger of damage and falling if the specified fixing points are not used</p> <ul style="list-style-type: none"> ▶ Fix the door system at all of the fixing points specified in these instructions and the table of fitting dimensions. ▶ Do not deviate from the tolerances specified in the table of fitting dimensions for the fixing point positions.

4.1.6 Fixing material

 WARNING
<p>Danger of damage and falling when unsuitable fixing material is used</p> <ul style="list-style-type: none"> ▶ The fitter must check the suitability of the provided fixing material for use in the intended fitting location; other fixing material must be used if the provided fixing material is suitable for concrete (≥ C 20 / 25), but is not officially approved. ▶ When fastening the door system to a building structure made of gas concrete, always provide a steel base construction.

NOTICES:

- Check whether the fixing material intended for use with the existing building structure has been included / is available.
- Only use the fixing material listed in the following table.

Support brackets

Steel	Screw DIN 933 M8 × 40 A4
	Washer DIN 9021 8.4 A4
	Washer DIN 9021-8.4 plastic
	Nut DIN 934-8-A4
Concrete / brickwork	Shark Pro 12
	Screw LK10 × 80 T40
Timber	Screw LK10 × 80 T40

Guide rails

Steel	Screw DIN 7981C T30 6.3 × 80
Concrete / brickwork	W-RD 8 × 30 / 100
	Wood screw LK6 × 100 T30
Timber	Wood screw LK6 × 100 T30

Plug-and-screw fitting

NOTICES:

Only fit the plugs if the following prerequisites are fulfilled:

- The building structure is at least 30 mm thicker than the depth of the drill hole.
- The edge distance from the drill hole to the building structure edge is at least 50 mm.

Only use new plug sleeves.

Procedure:

1. Drill the hole at a right angle to the surface.
2. Remove the drilling dust from the drill hole.
3. Insert the plug sleeve into the drill hole by lightly hammering in with a mason's mallet until the collar is flush with the building structure or structural component.
4. Tighten the screw until the component is firmly fastened to the building structure.
The following conditions must be met:
 - It must be difficult to turn the screw further.
 - The plug sleeve must not turn with the screw.

4.1.7 Protective films

ATTENTION

Malfunction due to protective film not being removed

- ▶ Remove the protective films applied at the factory before fitting all door components.

4.1.8 Fitting aids

NOTE:

Use suitable tools and appropriate equipment for fitting the door system.

Have the following aids ready:

- A suitable lifting device (forklift, handlift) to position the door system in the building structure.
- A suitable lifting platform or scaffold

4.1.9 Additional door components

Before fitting the door, install the following components (if provided):

- Additional posts
- Fascia panel

During fitting, observe the data stated in the following documents:

- Fitting dimension sheet
- Additional sheets

4.2 Fitting dimensions

m1.00	Reference plane finished floor level (FFL)
m1.01	Door width
m1.02	Door height
m1.03	Centre of door to fixing point of operator support bracket
m1.04	Centre of door to fixing point of bearing support bracket
m1.05	FFL to top fixing point of operator support bracket
m1.06	FFL to top fixing point of bearing support bracket
m1.07	From the wall to the centre of the winding shaft
m1.08	Support height
m1.09	Reveal to back edge of side guide
m1.10	Back edge of side guide on right to back edge of side guide on left
m1.11	FFL to lowermost fixing point of side guide
m1.12	Distance between side guide fixing points
m1.13	Bottom edge of lintel to bottom edge of lintel seal locating profile
m1.15	FFL to bottom fixing point of operator support bracket
m1.16	FFL to bottom fixing point of bearing support bracket
m1.17	Reveal to side guide fixing point
m1.18	FFL to centre of barrel
m1.19	Distance of top side guide fixing point
m2.00	Additional post width
m2.01	Additional post height
m3.00	Height of fascia panel

4.3 Fitting steps

Fit the door system using the following illustrations.

- Proceed carefully step by step.
- Observe all additional notes given.

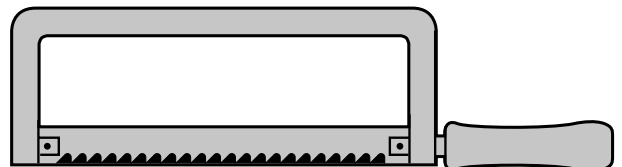
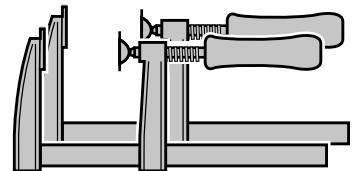
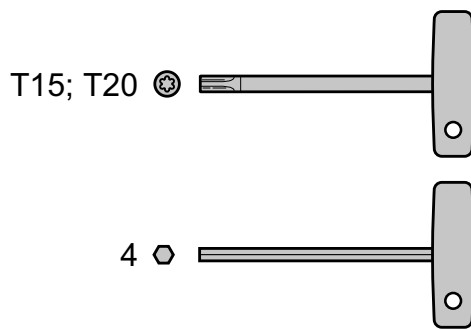
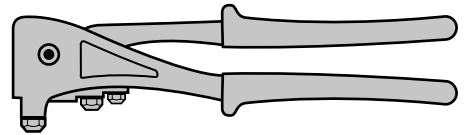
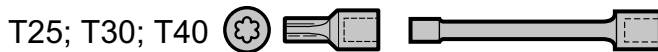
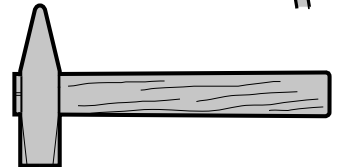
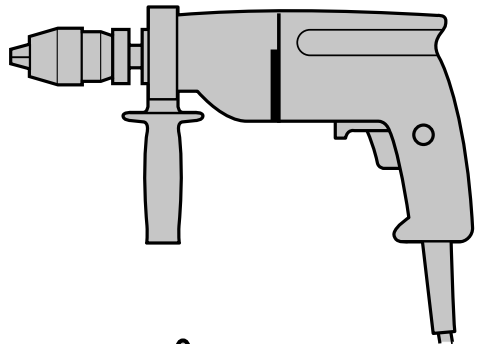
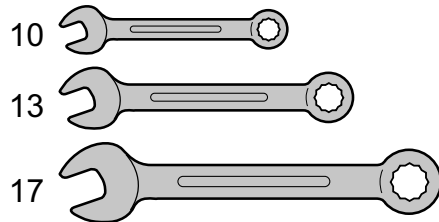
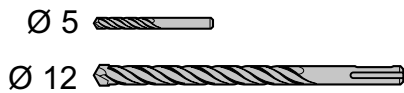
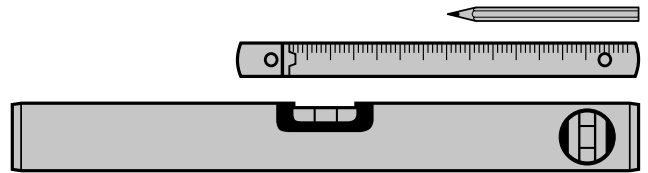
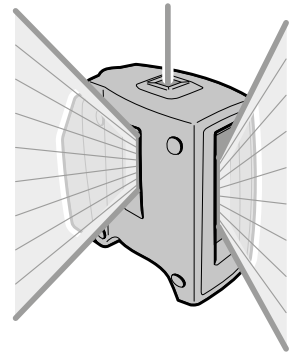
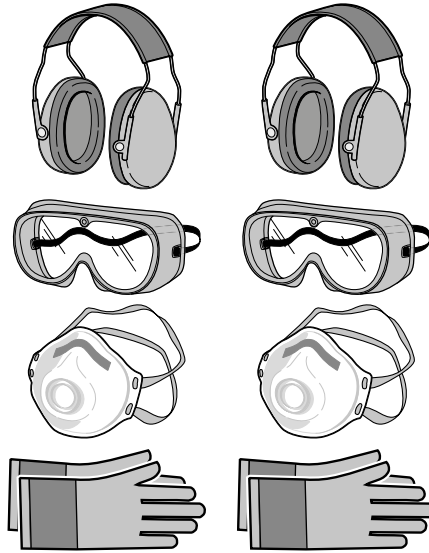
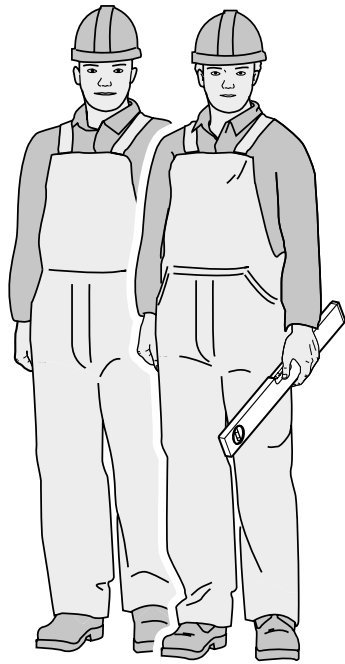

0

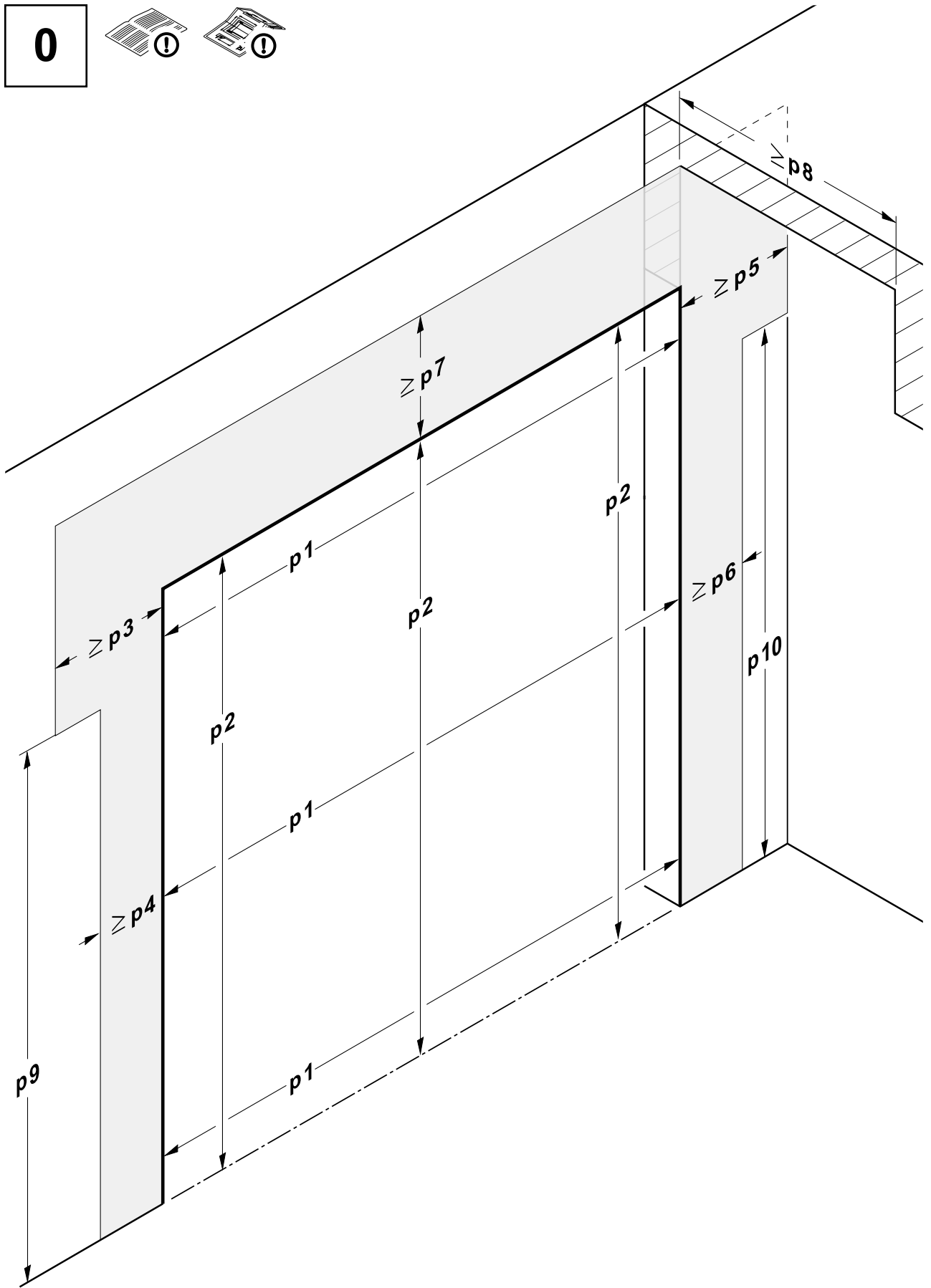

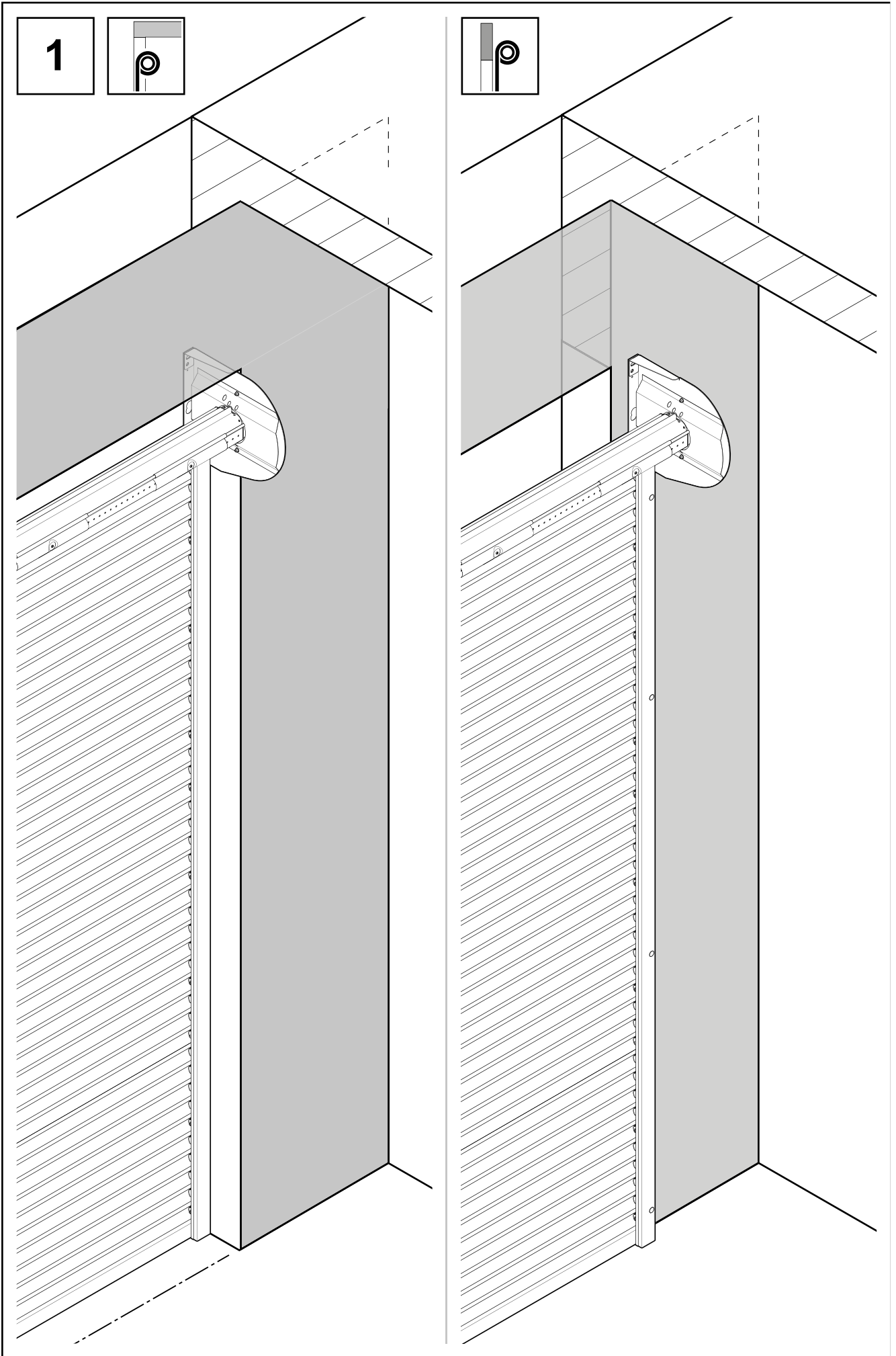

1.1

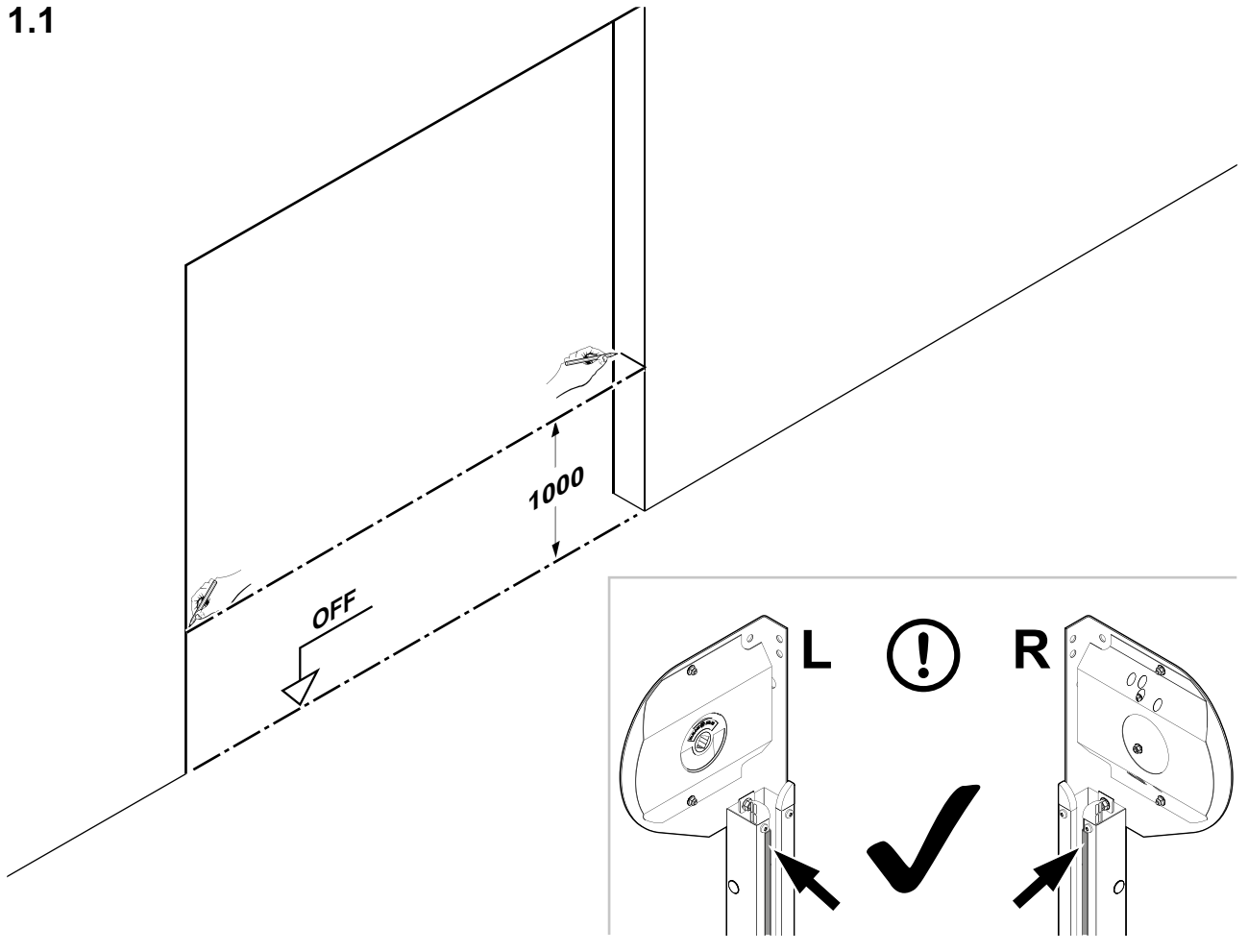

1.2

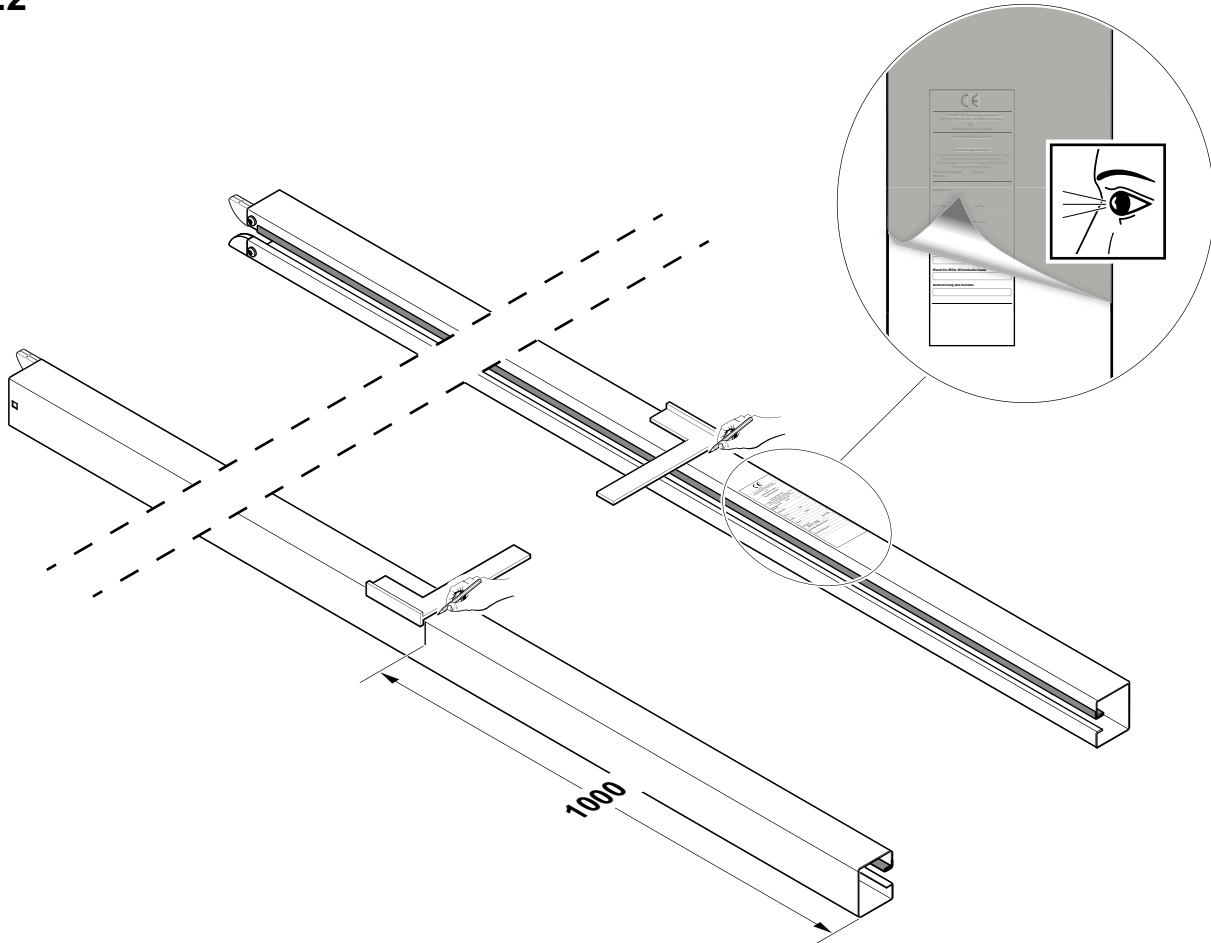

1.3

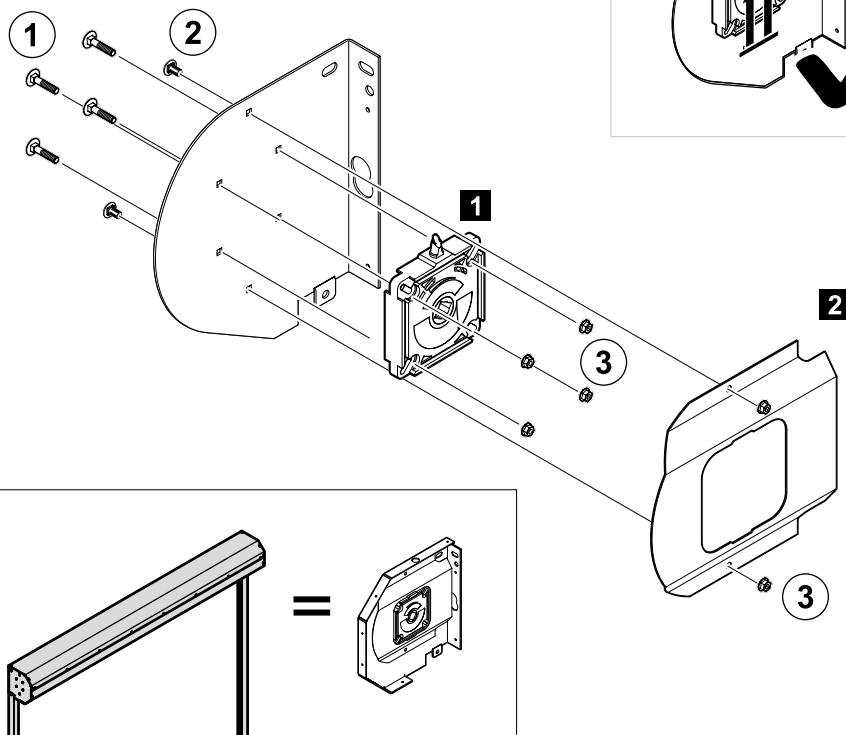

1	DIN 603 M6x30 8.8 vz
2	DIN 603 M6x12 8.8 vz
3	DIN 6923 M6-8-vz

1.4

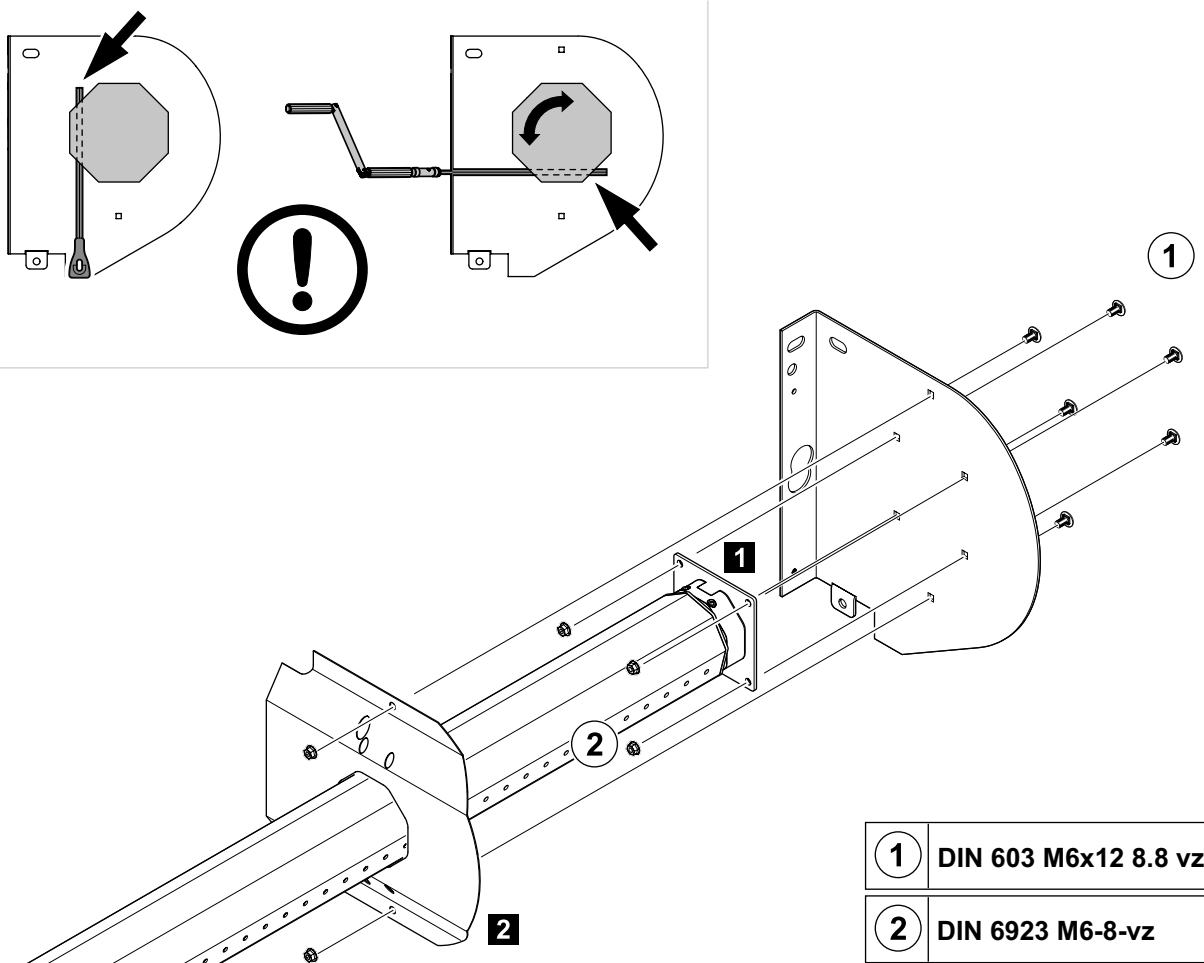

1	DIN 603 M6x12 8.8 vz
2	DIN 6923 M6-8-vz

1.5

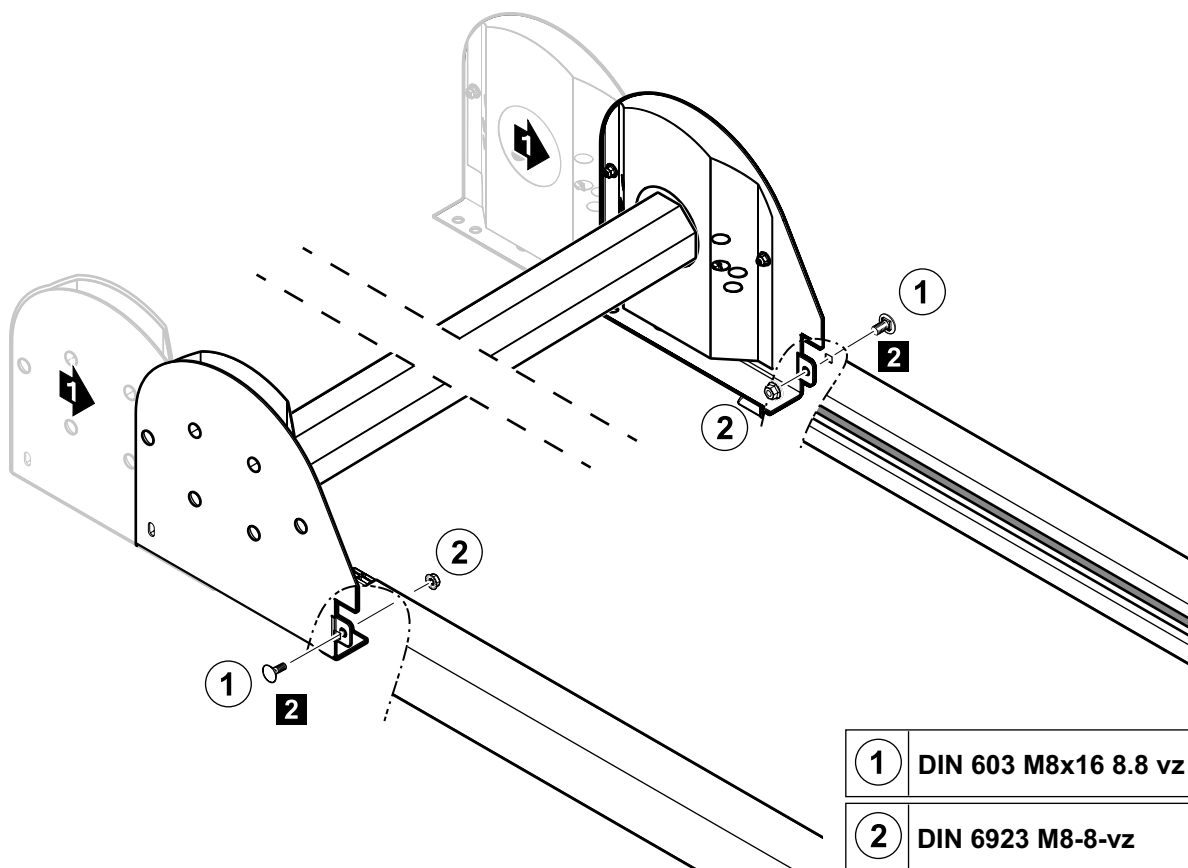

1.6

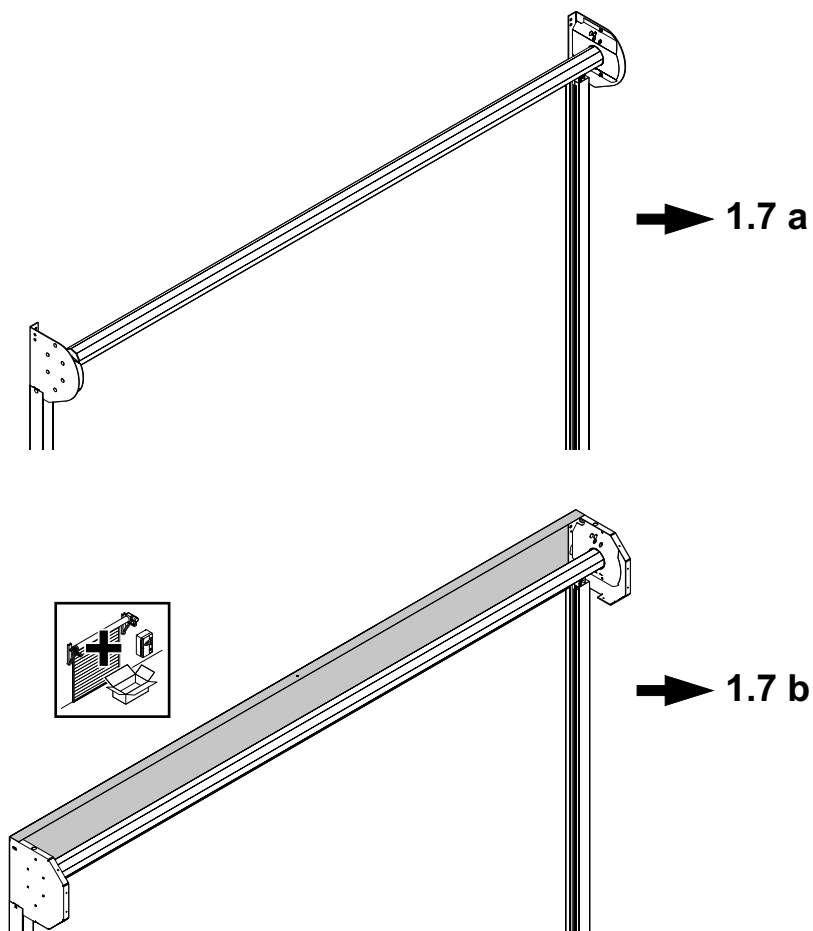

1.7 a

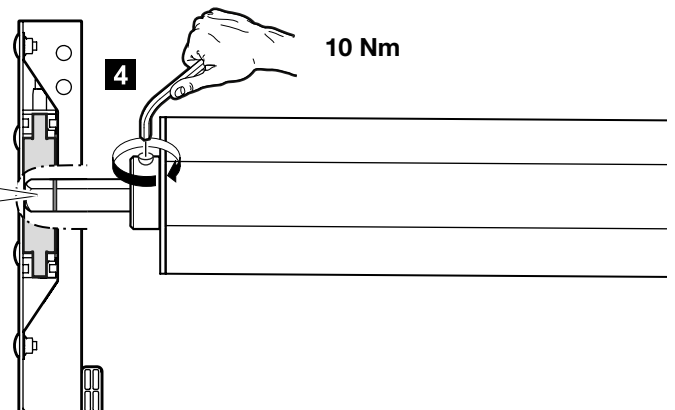
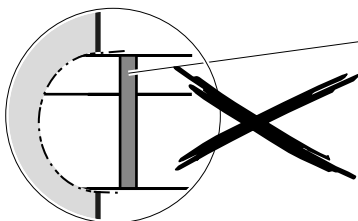
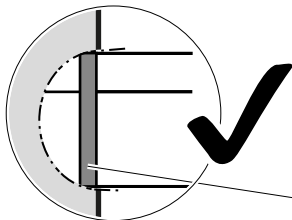
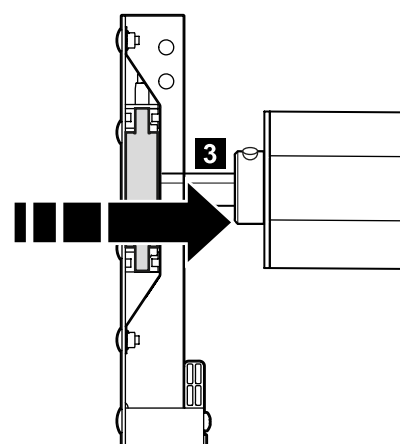
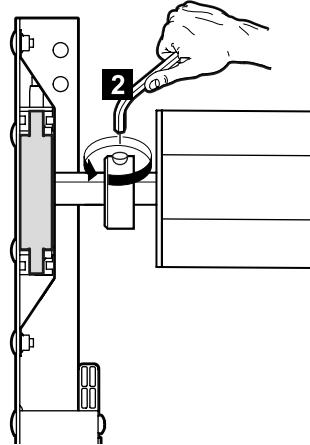
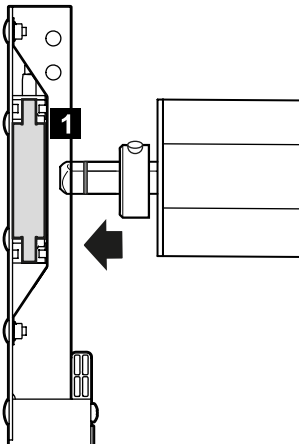
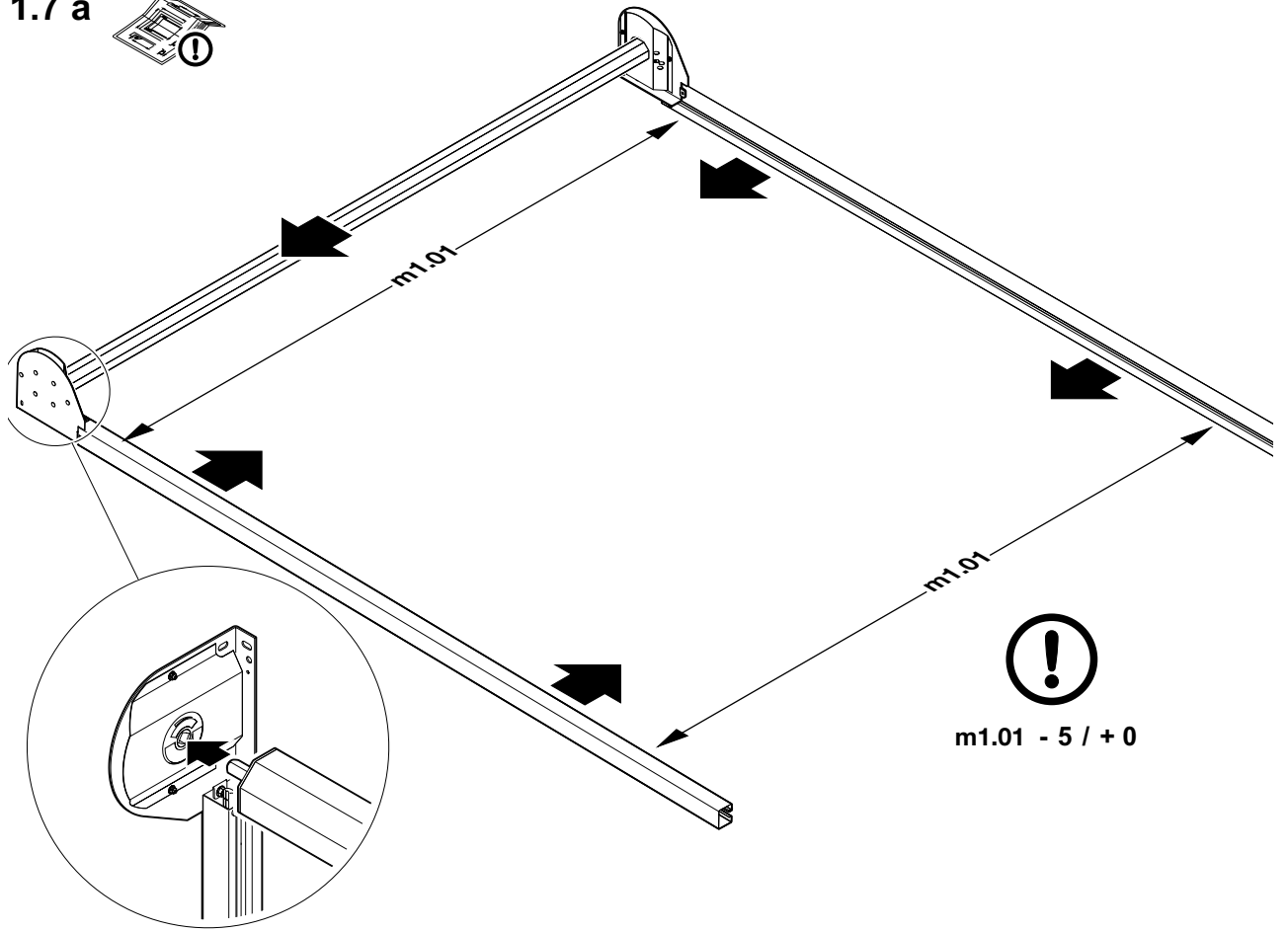

1.7 b

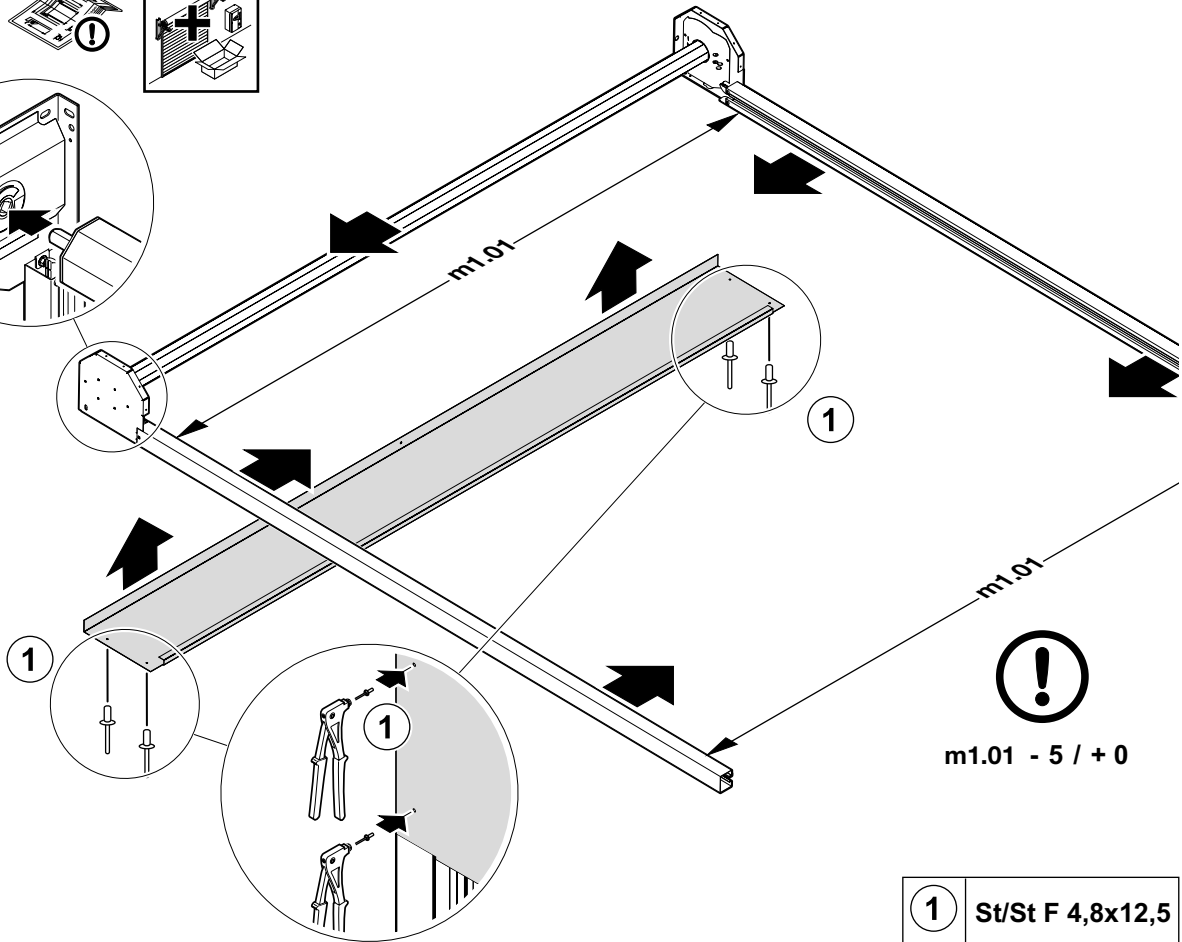
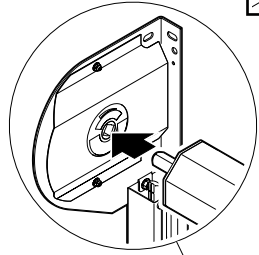
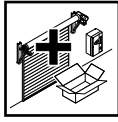

m1.01 - 5 / + 0

1 St/St F 4,8x12,5

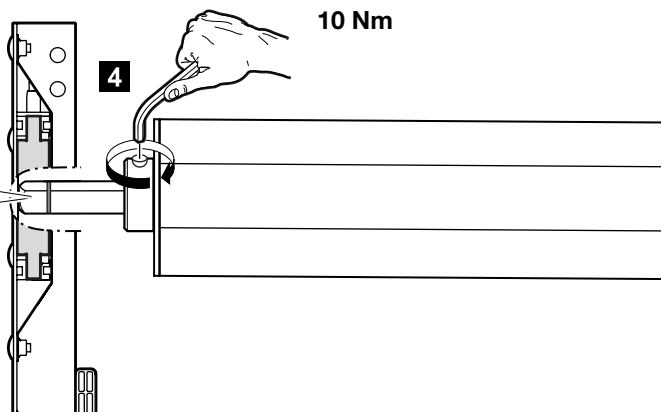
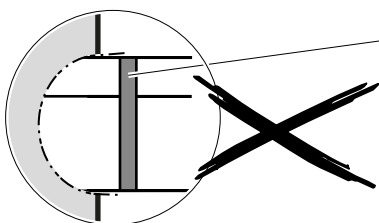
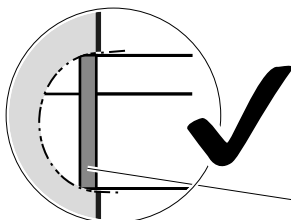
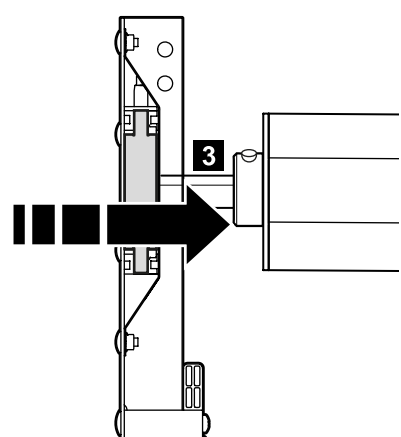
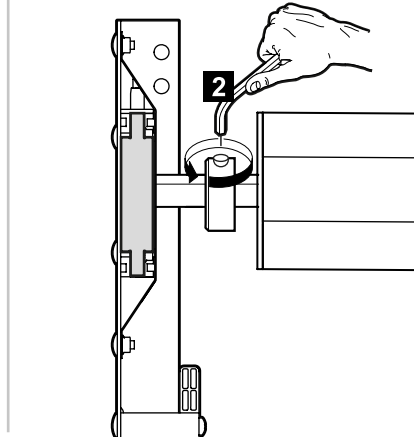
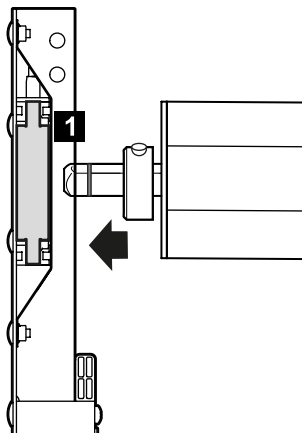

1.8 a

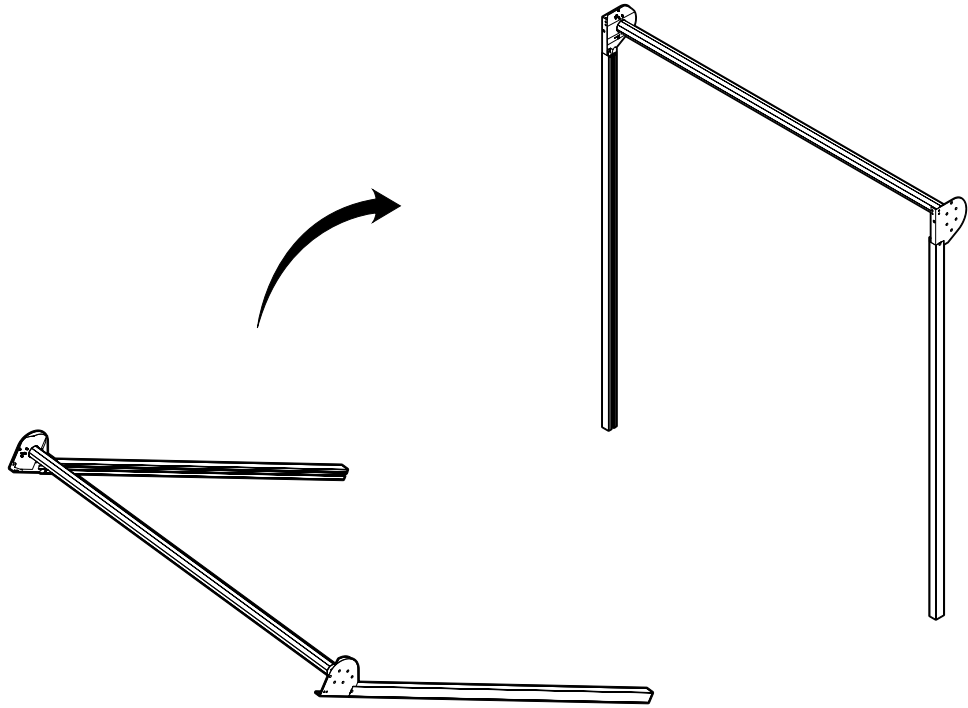

1.8 b

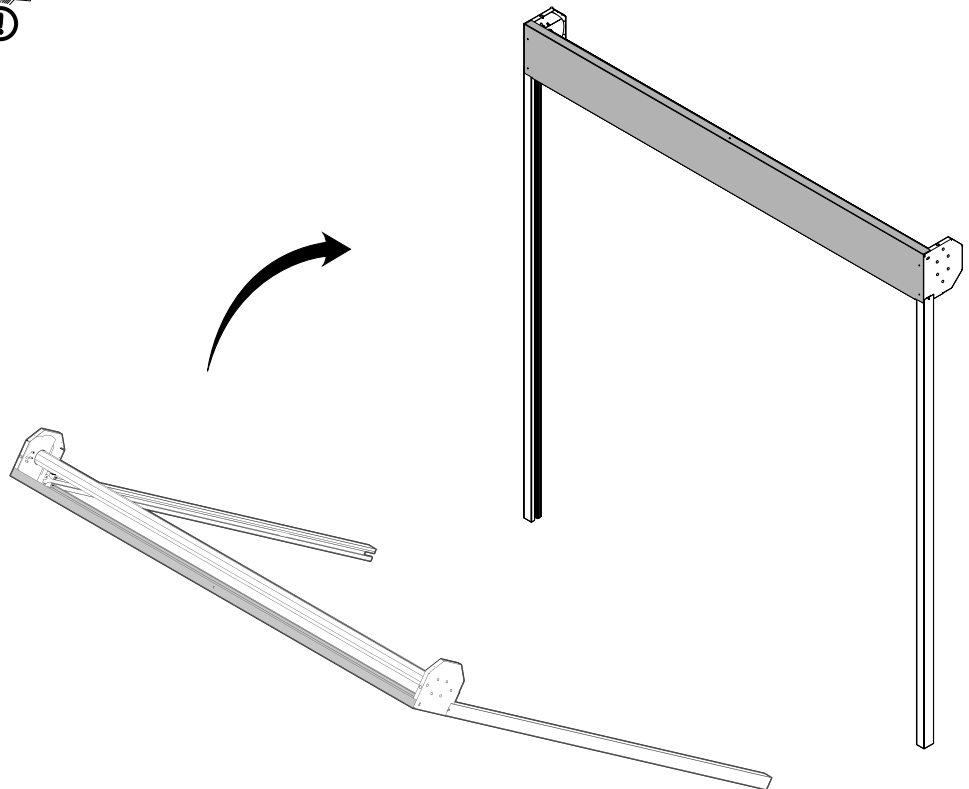

1.9 a

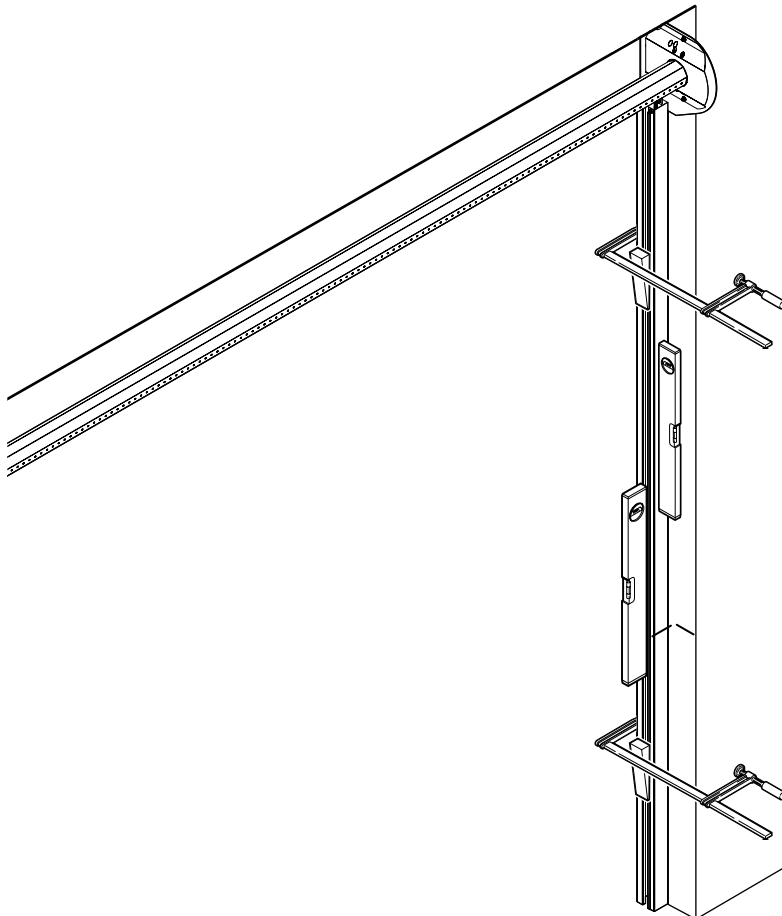
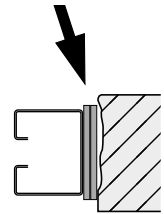
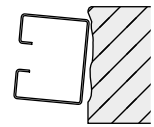
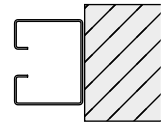
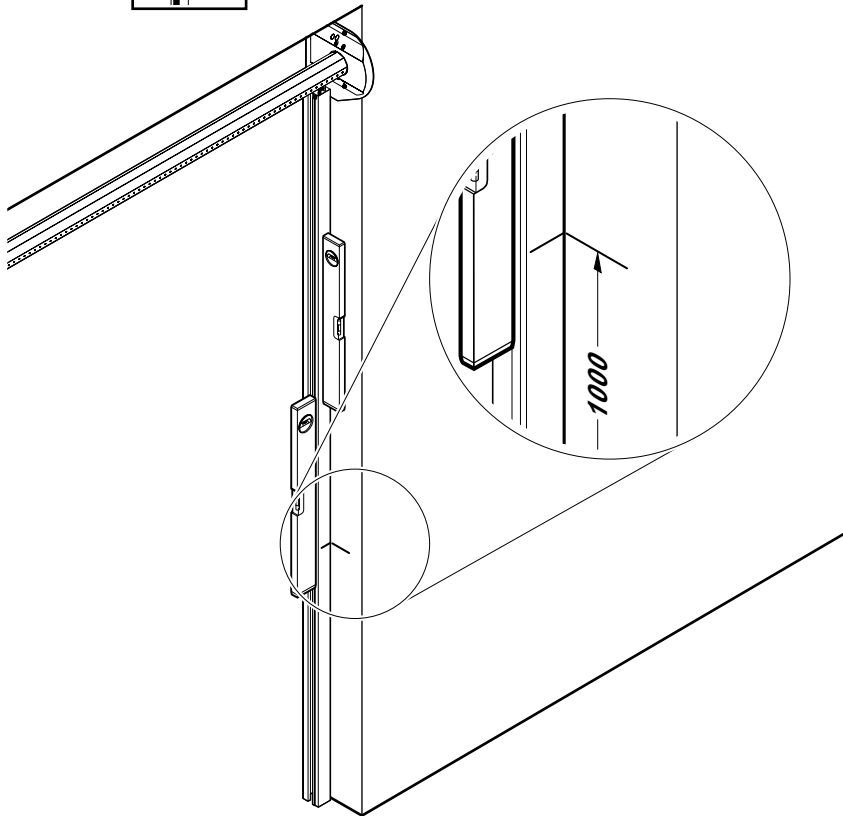
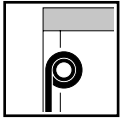

1.9 b

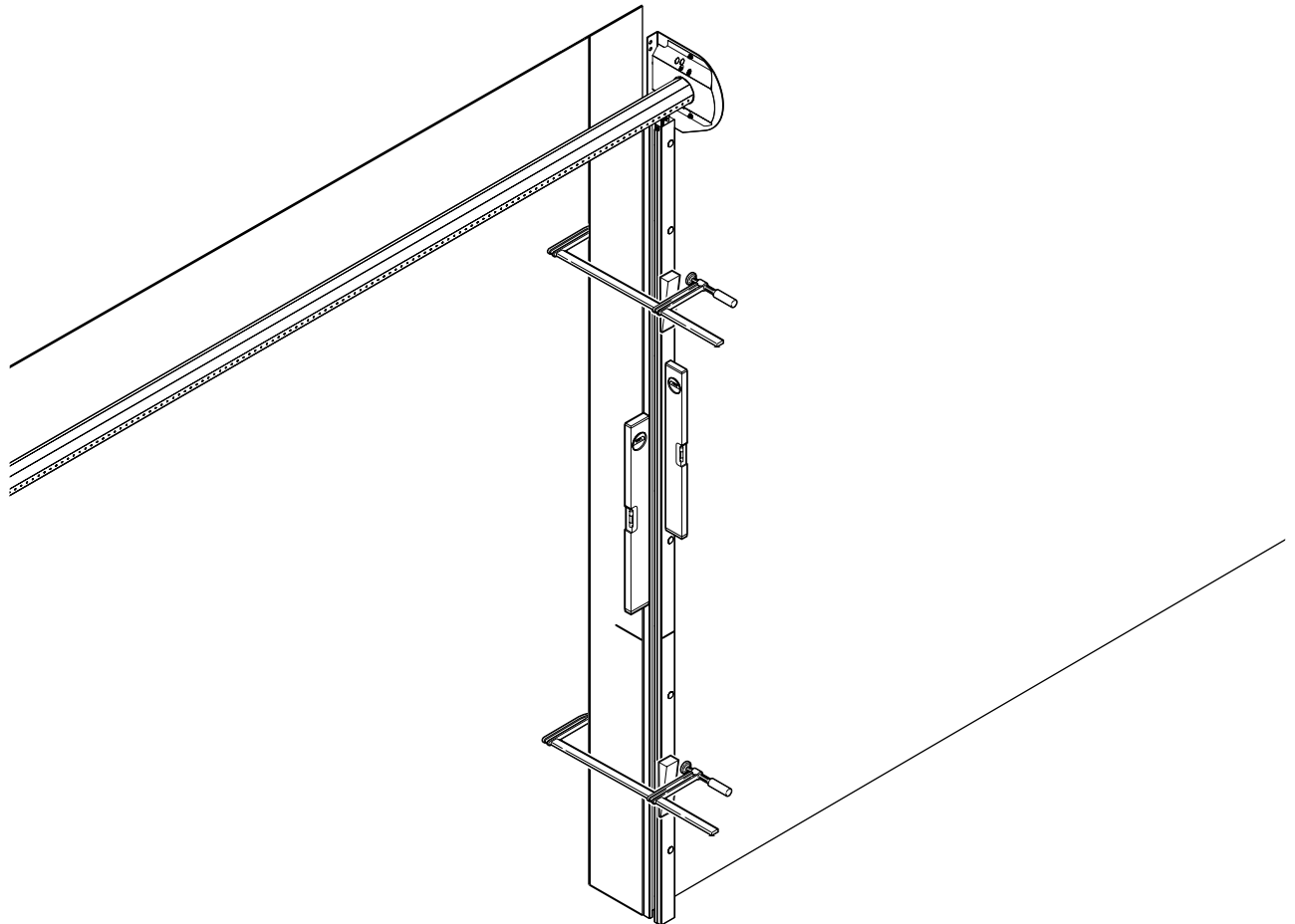
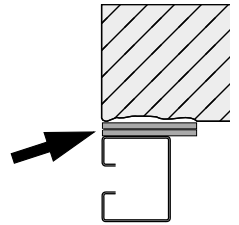
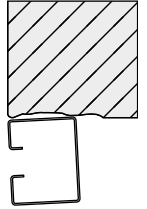
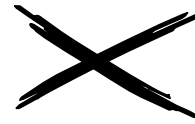
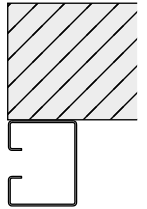
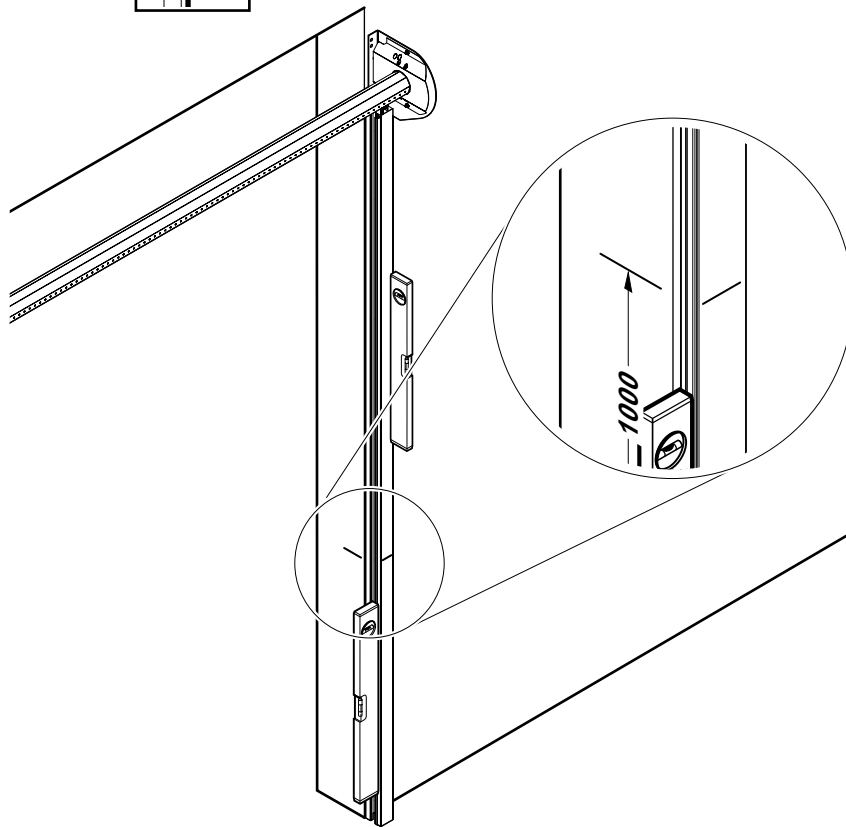
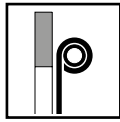

1.10 A

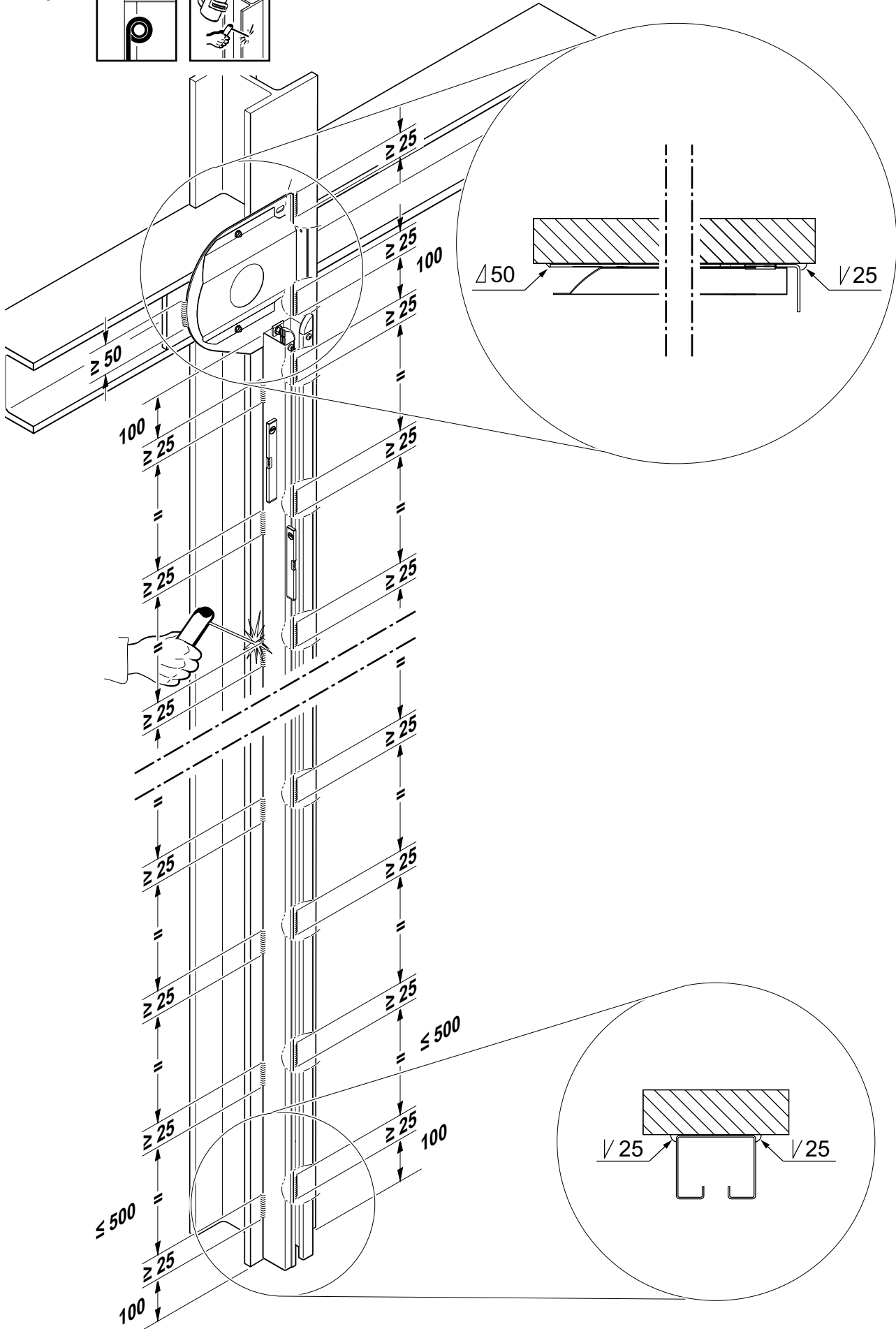
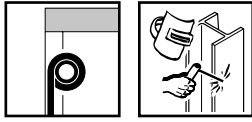

1.10 C

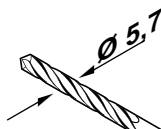
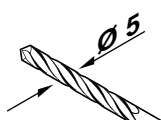
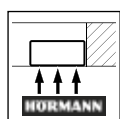
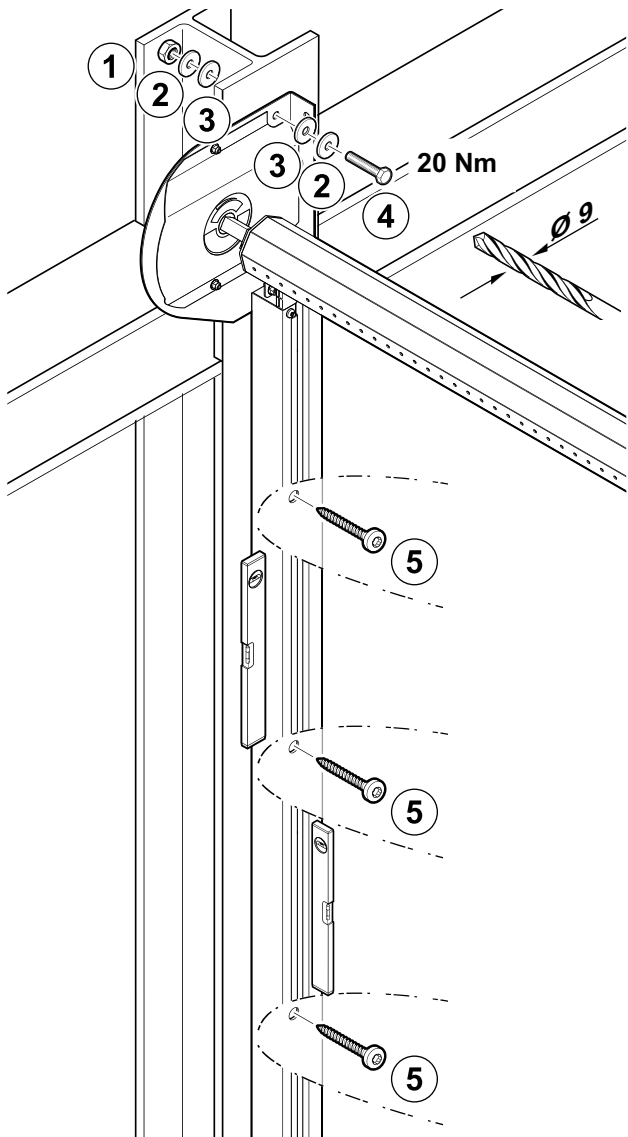
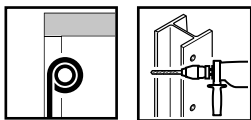

1	DIN 934 8 A4
2	DIN 9021-8,4 A4
3	DIN 9021-8,4 KS
4	DIN 933 M8x40 A4
5	DIN 7981C T30 6,3x80

1.10 D

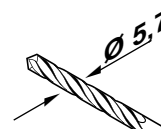
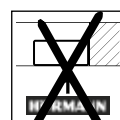
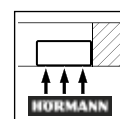
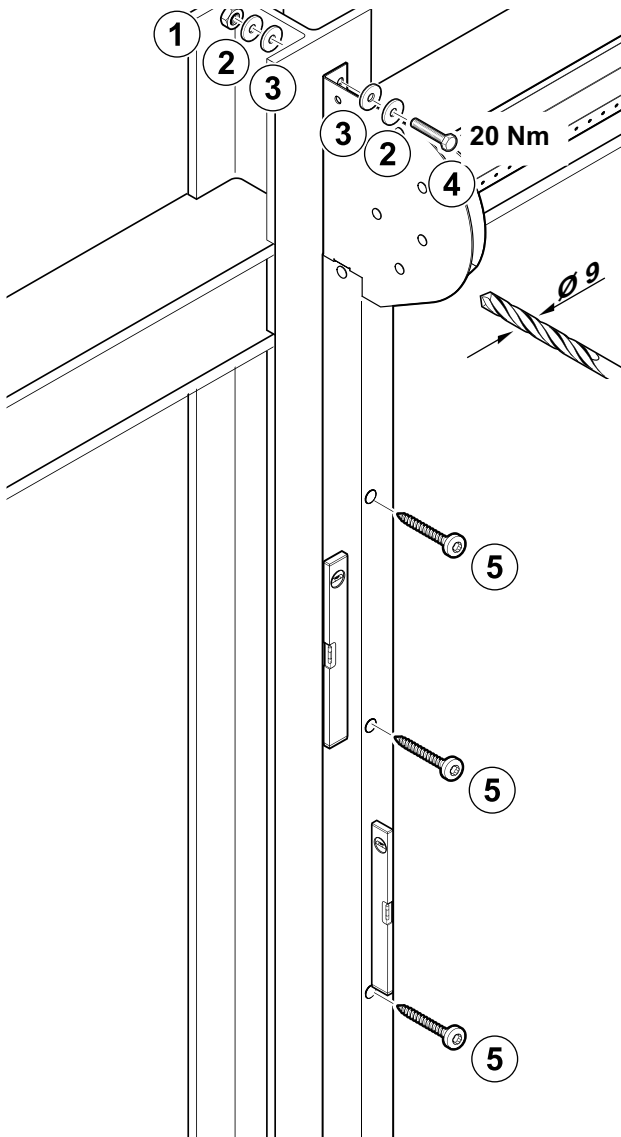
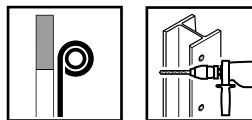

1	DIN 934 8 A4
2	DIN 9021-8,4 A4
3	DIN 9021-8,4 KS
4	DIN 933 M8x40 A4
5	DIN 7981C T30 6,3x80

1.10 E

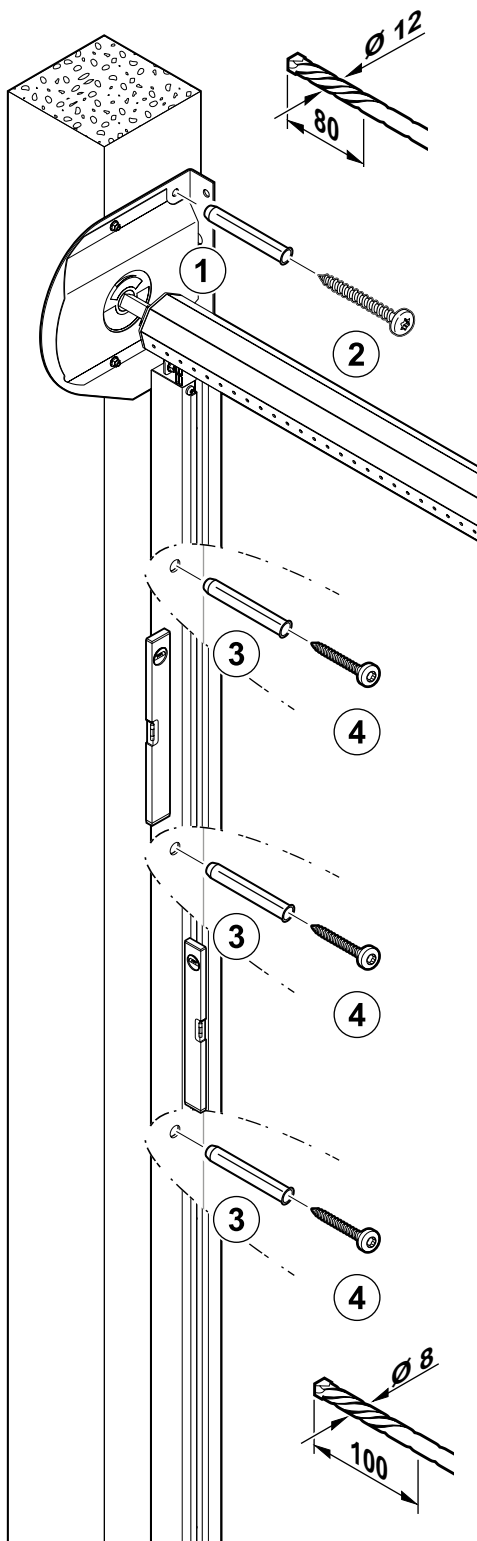
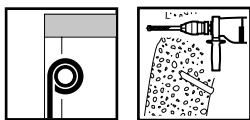

1	Shark Pro 12
2	LK 10x80 T40
3	W-RD 8x30/100
4	LK 6x100 T30

1.10 F

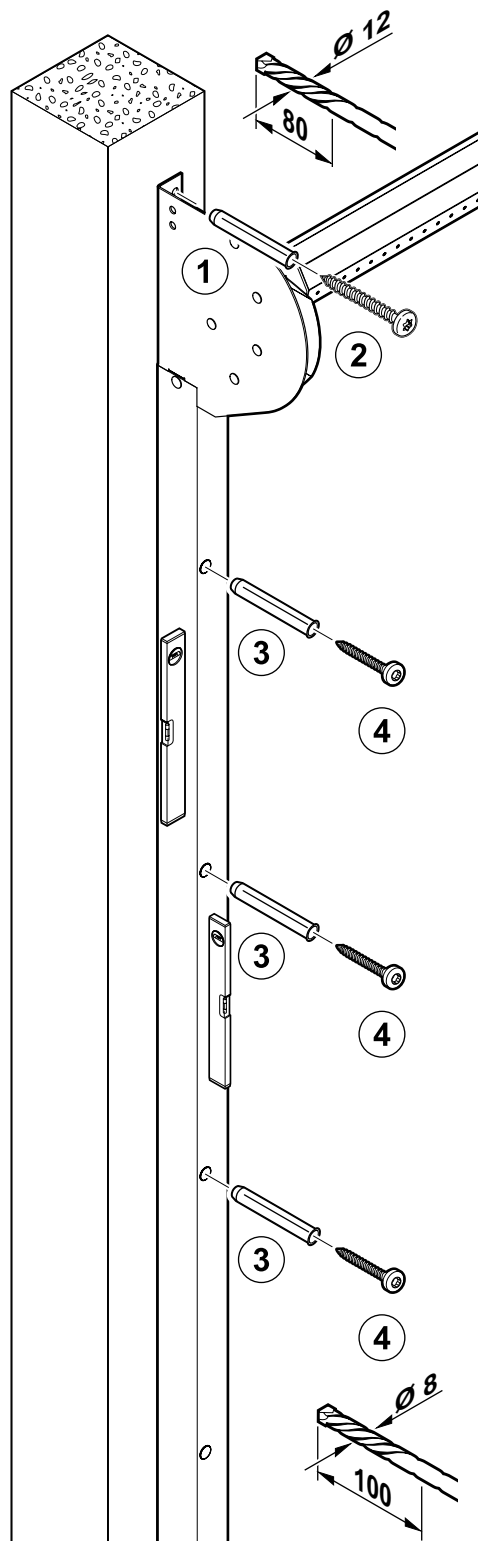
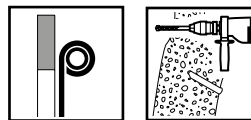

1	Shark Pro 12
2	LK 10x80 T40
3	W-RD 8x30/100
4	LK 6x100 T30

1.10 G

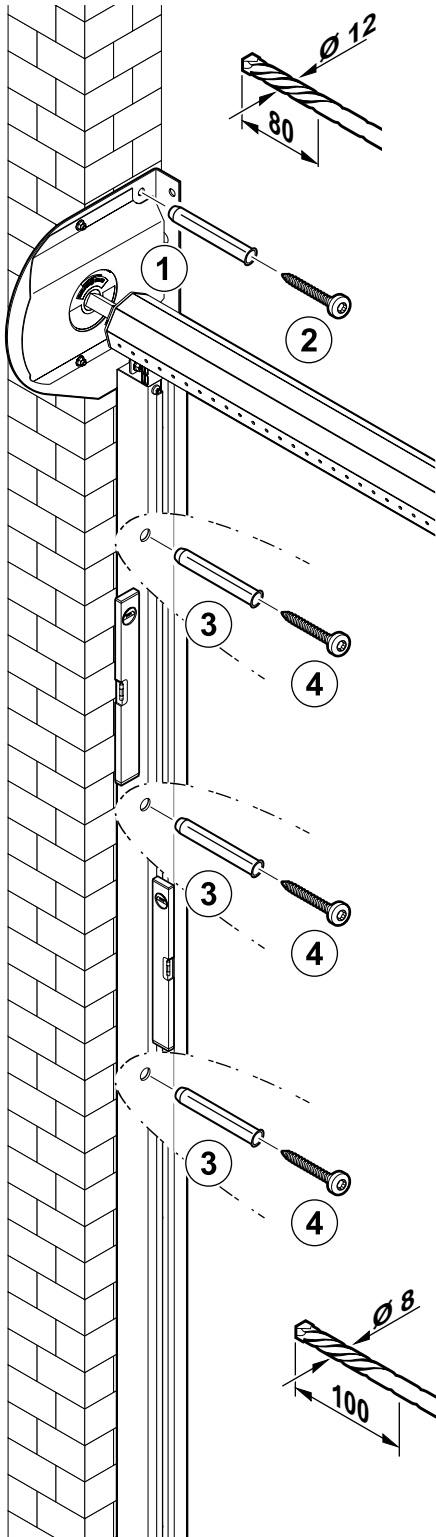
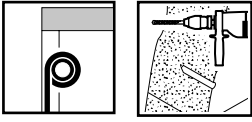

1	Shark Pro 12
2	LK 10x80 T40
3	W-RD 8x30/100
4	LK 6x100 T30

1.10 H

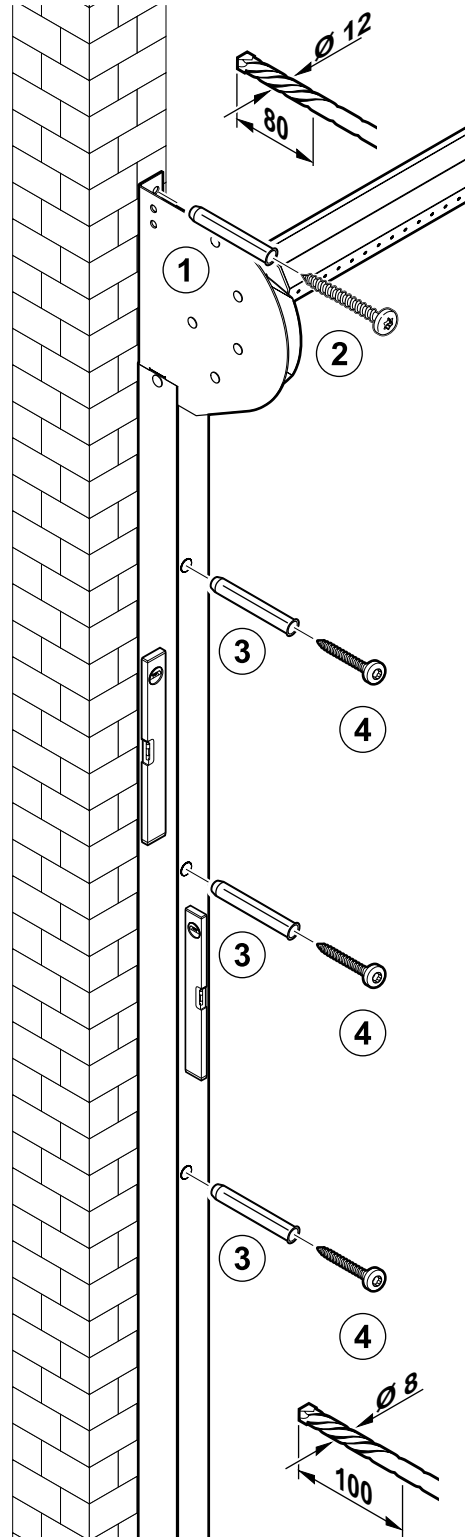
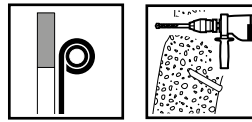

1	Shark Pro 12
2	LK 10x80 T40
3	W-RD 8x30/100
4	LK 6x100 T30

1.10 I

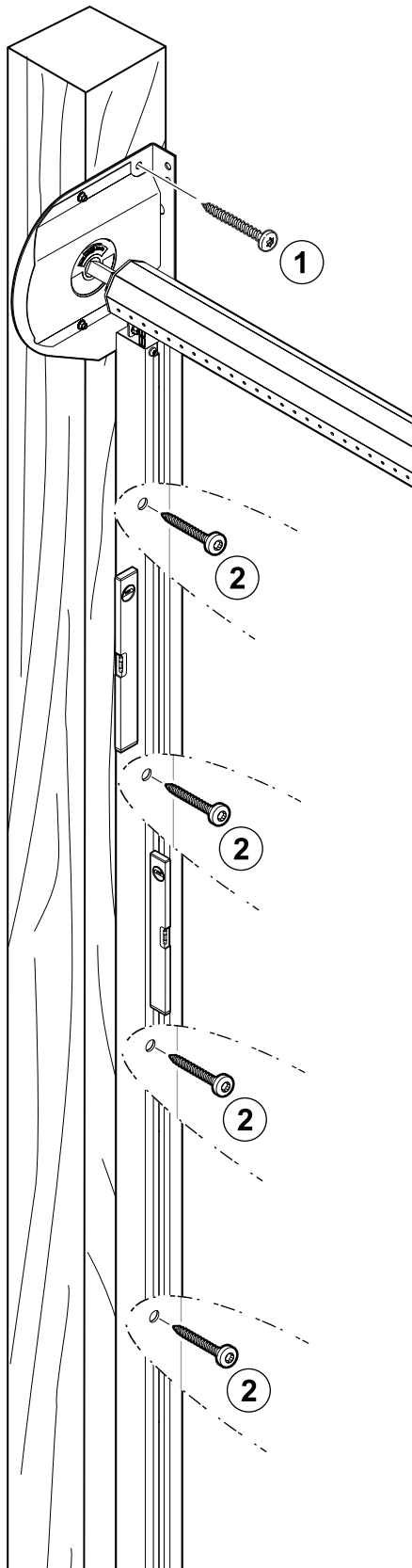
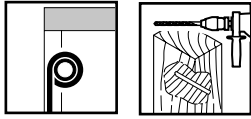

1	LK10x80 T40
2	LK 6x100 T30

1.10 J

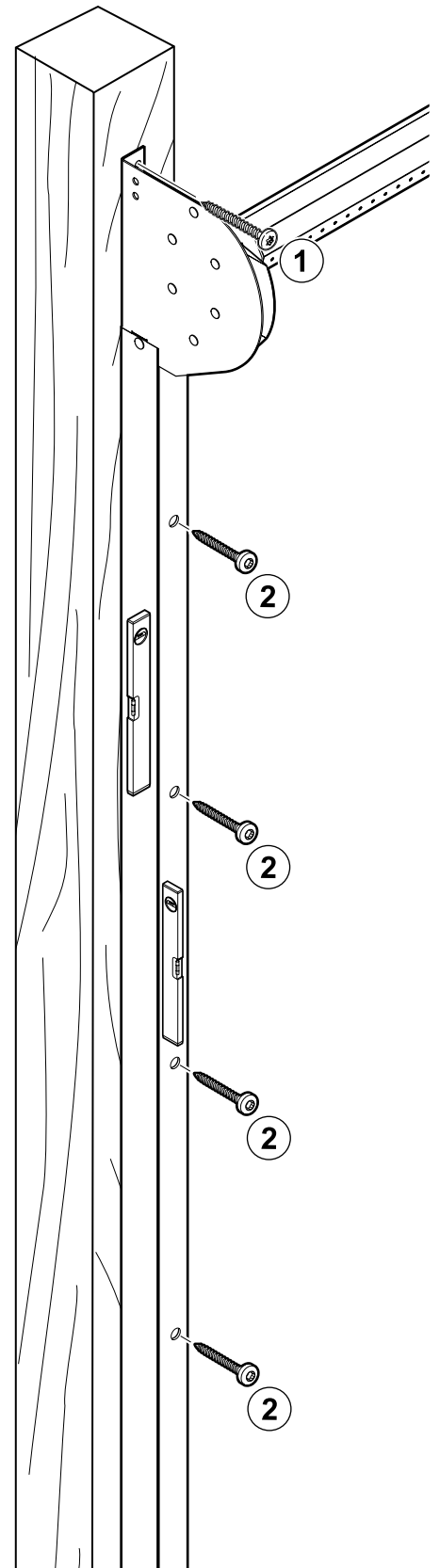
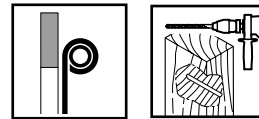

1	LK10x80 T40
2	LK 6x100 T30

2A

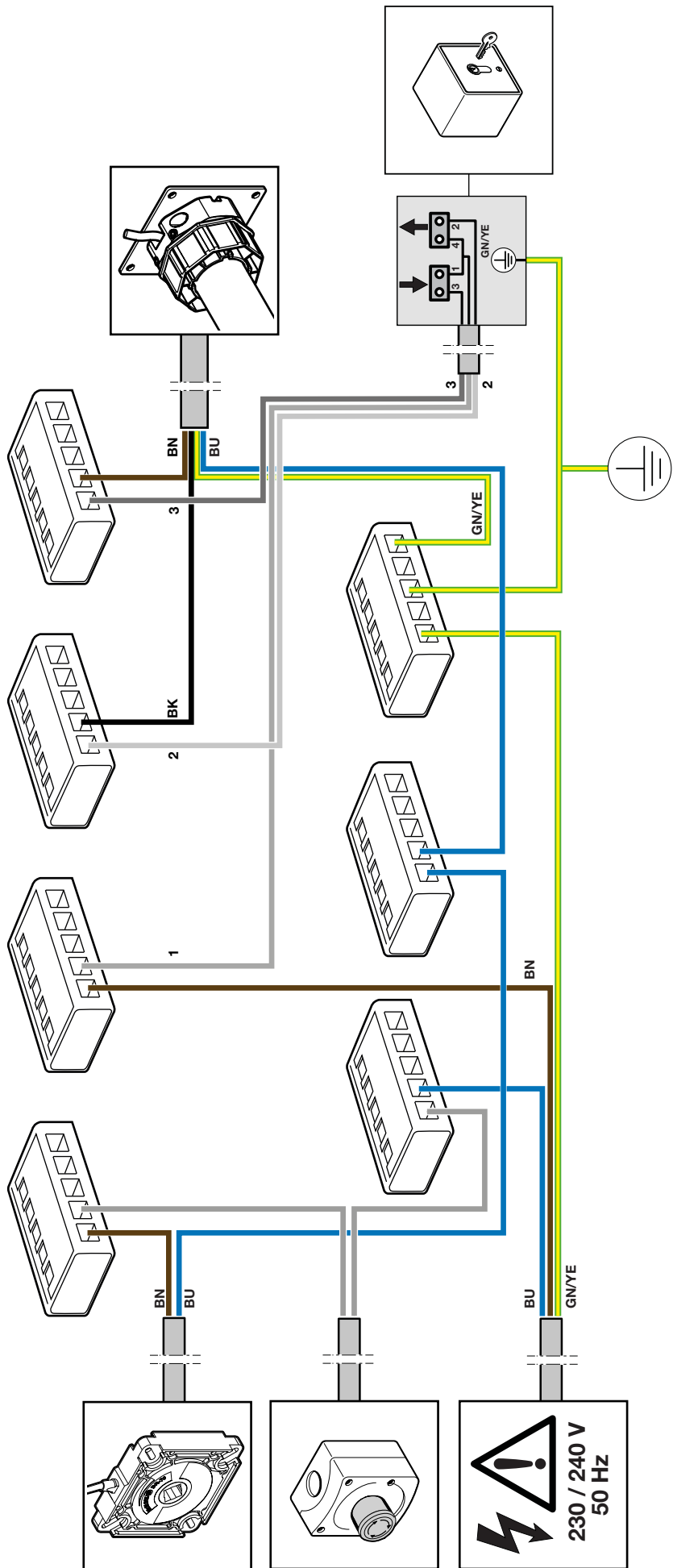

2B

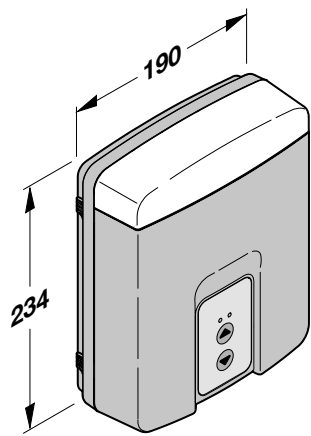
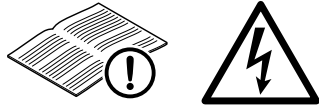

2B.1

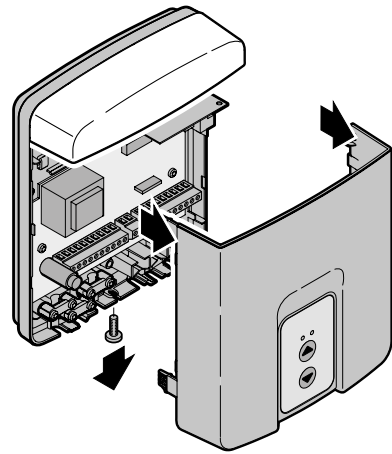

1

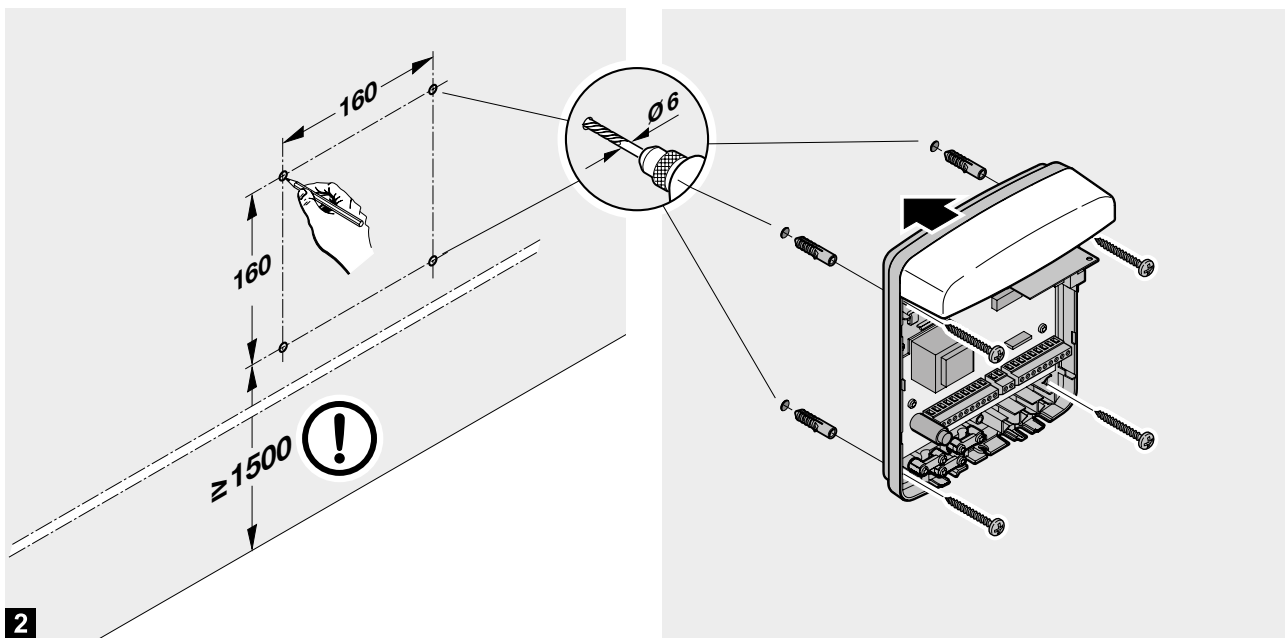

2

2B.2

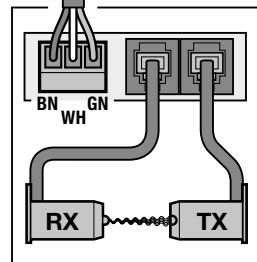
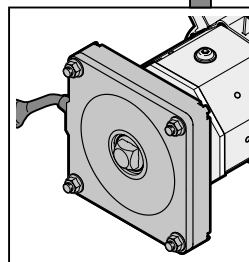
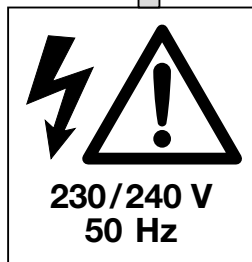
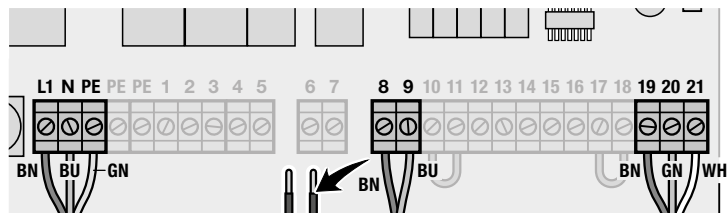
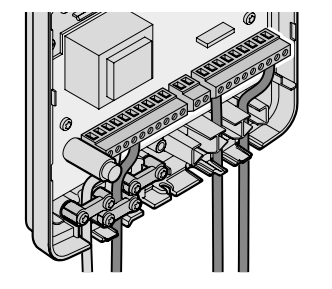

2B.3

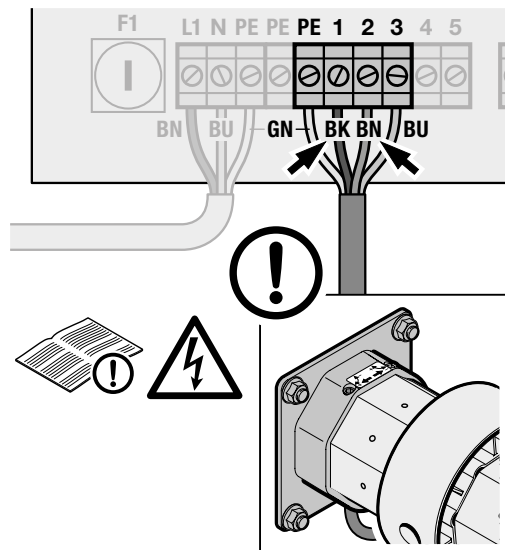
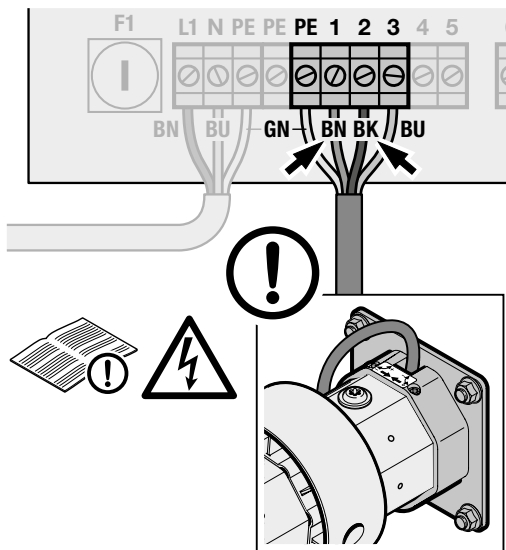
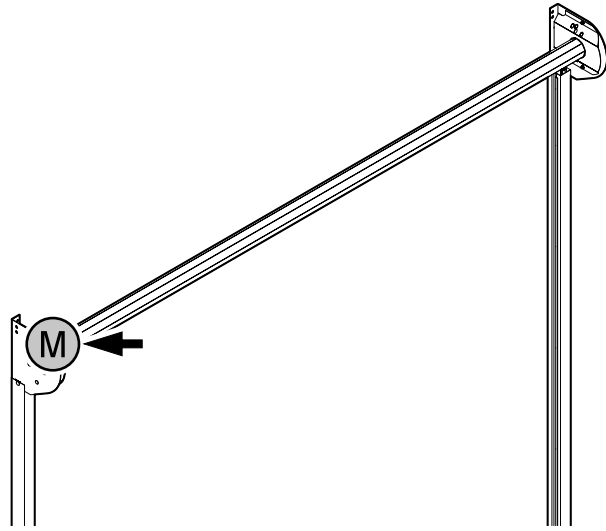
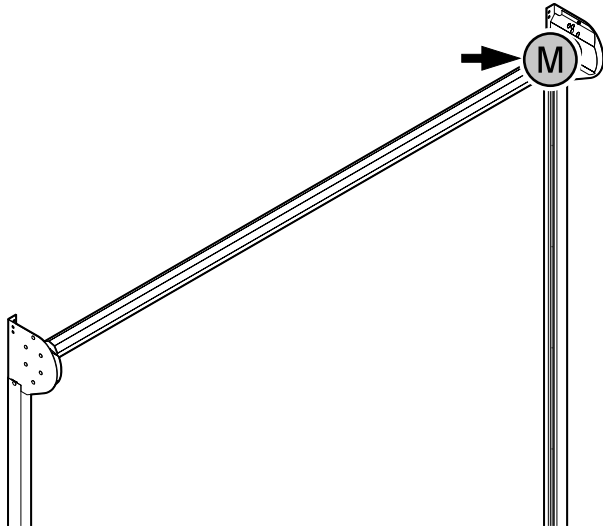

2B.4

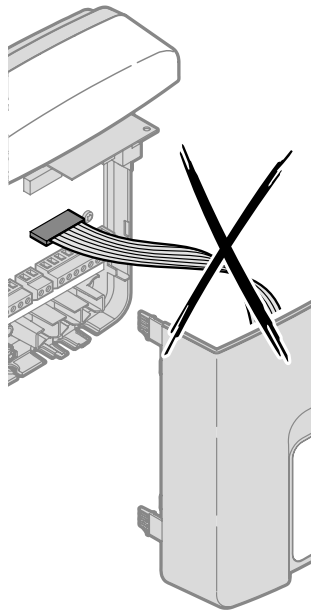
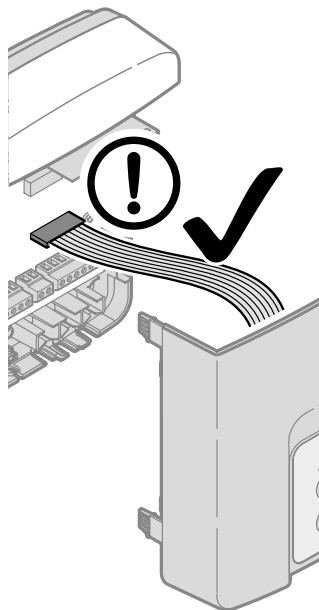
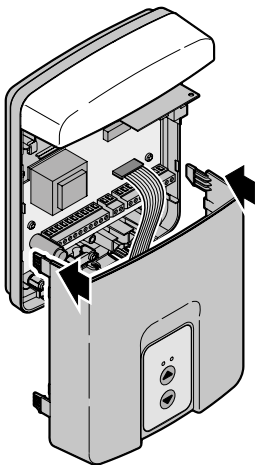

2B.5

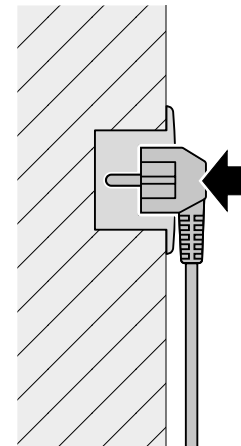
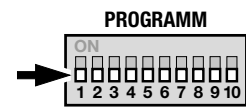

3

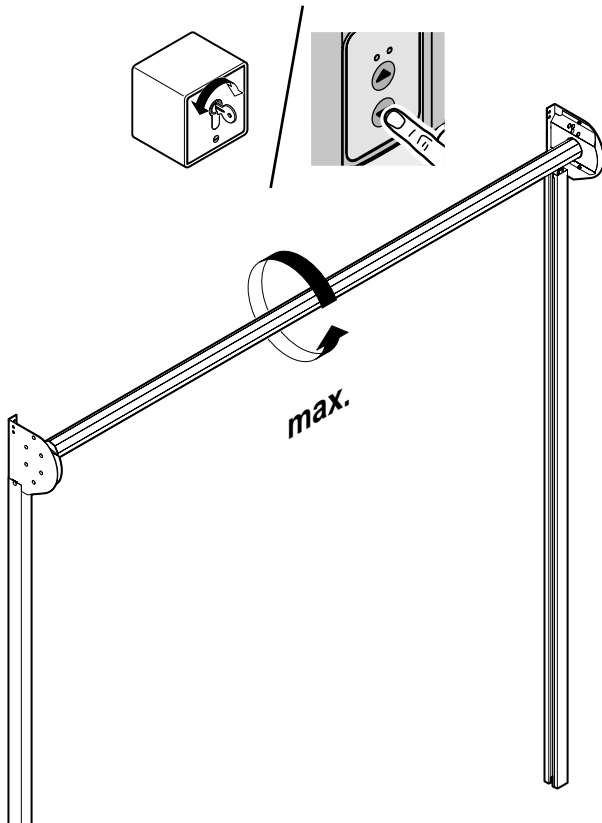

3.1

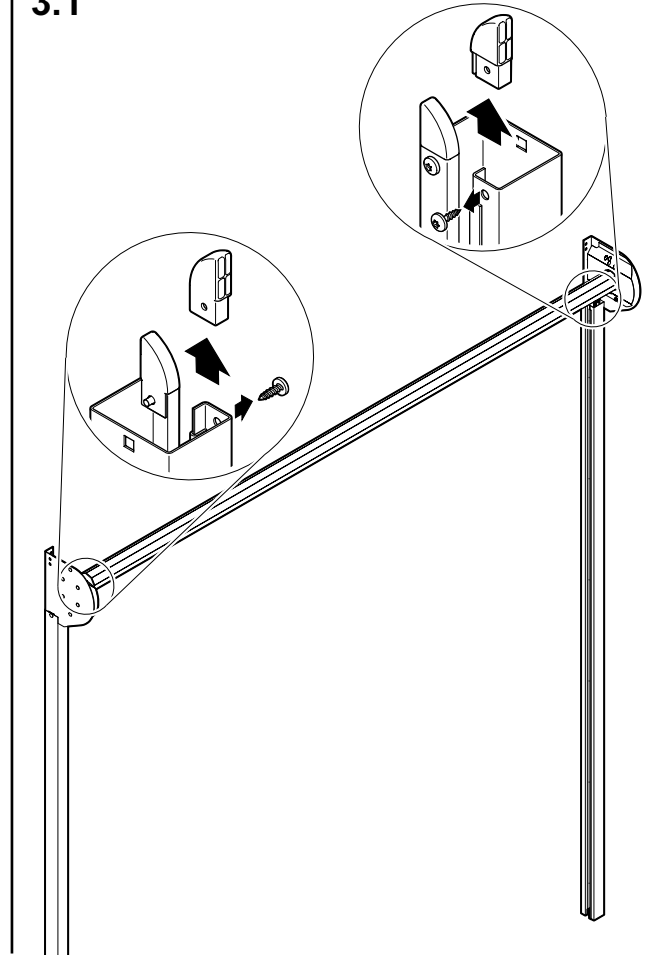

3.2

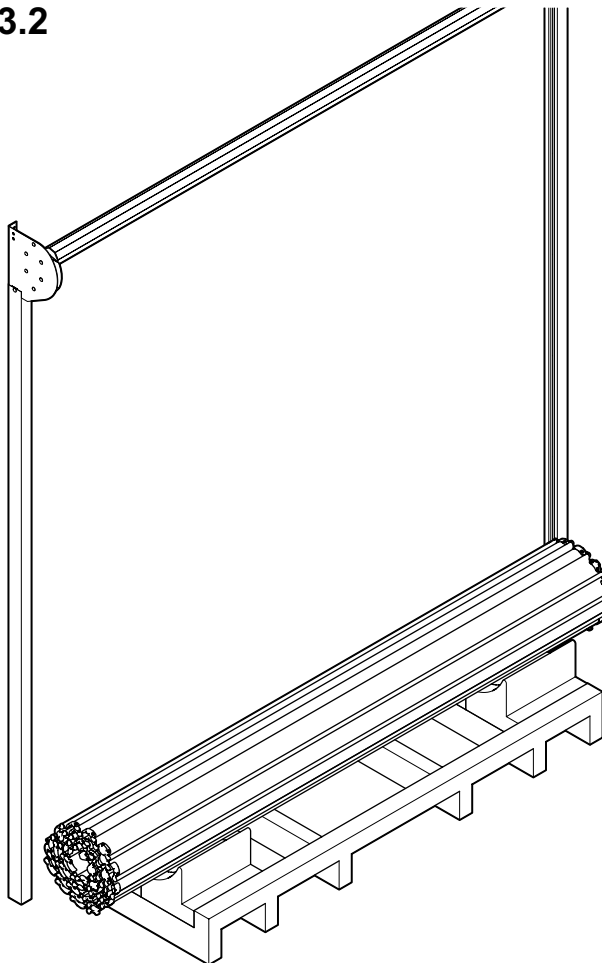

a = a

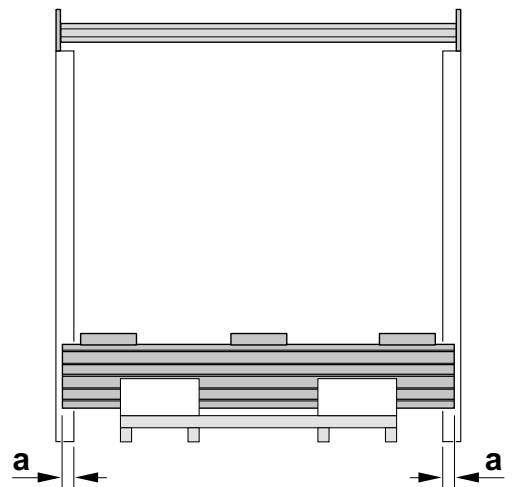

3.3

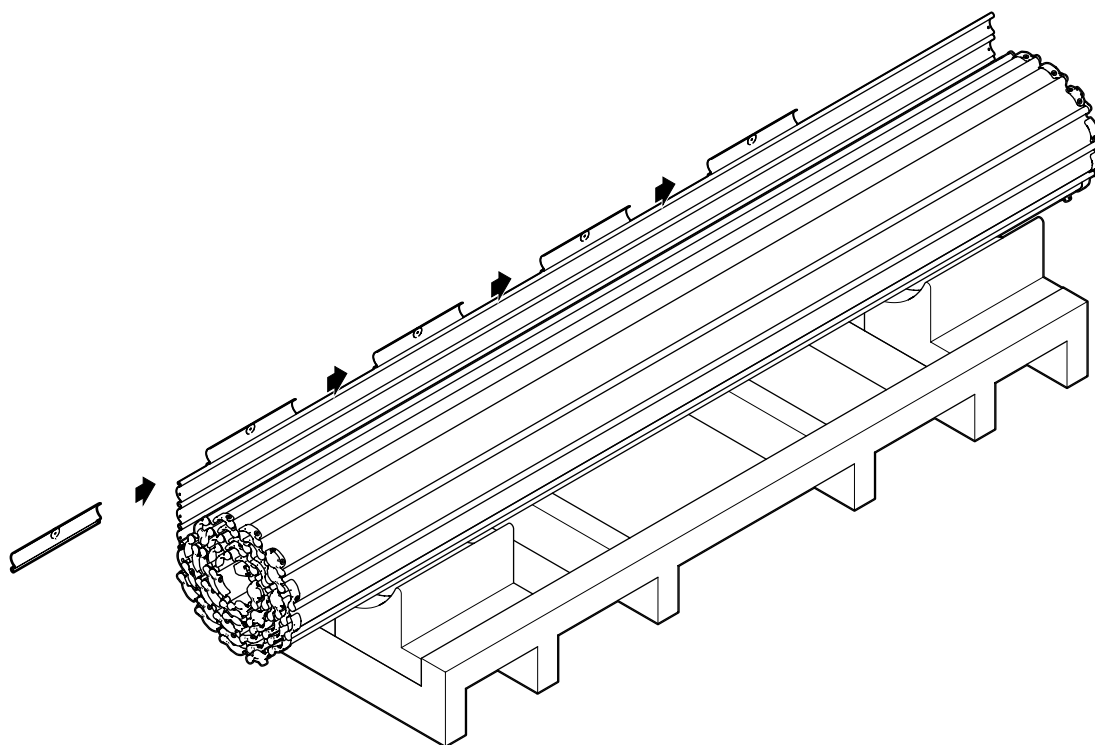

3.4

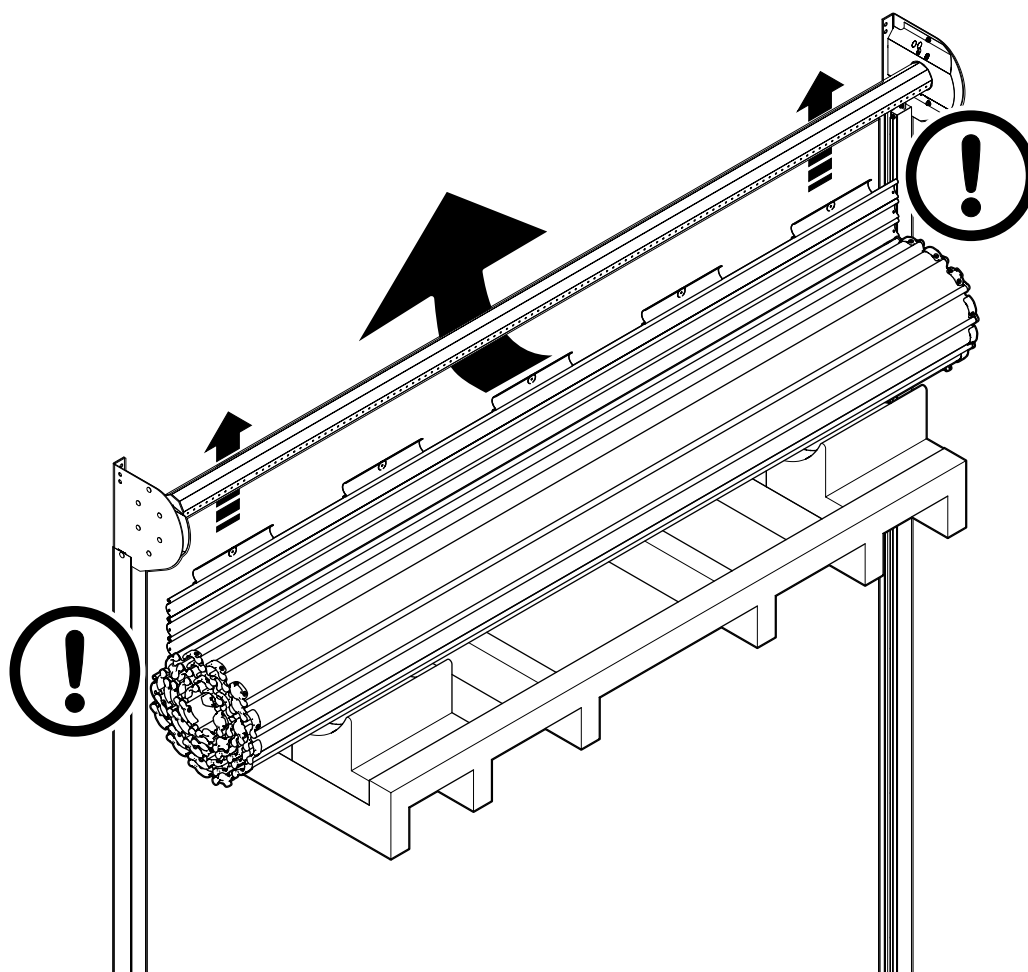

3.5

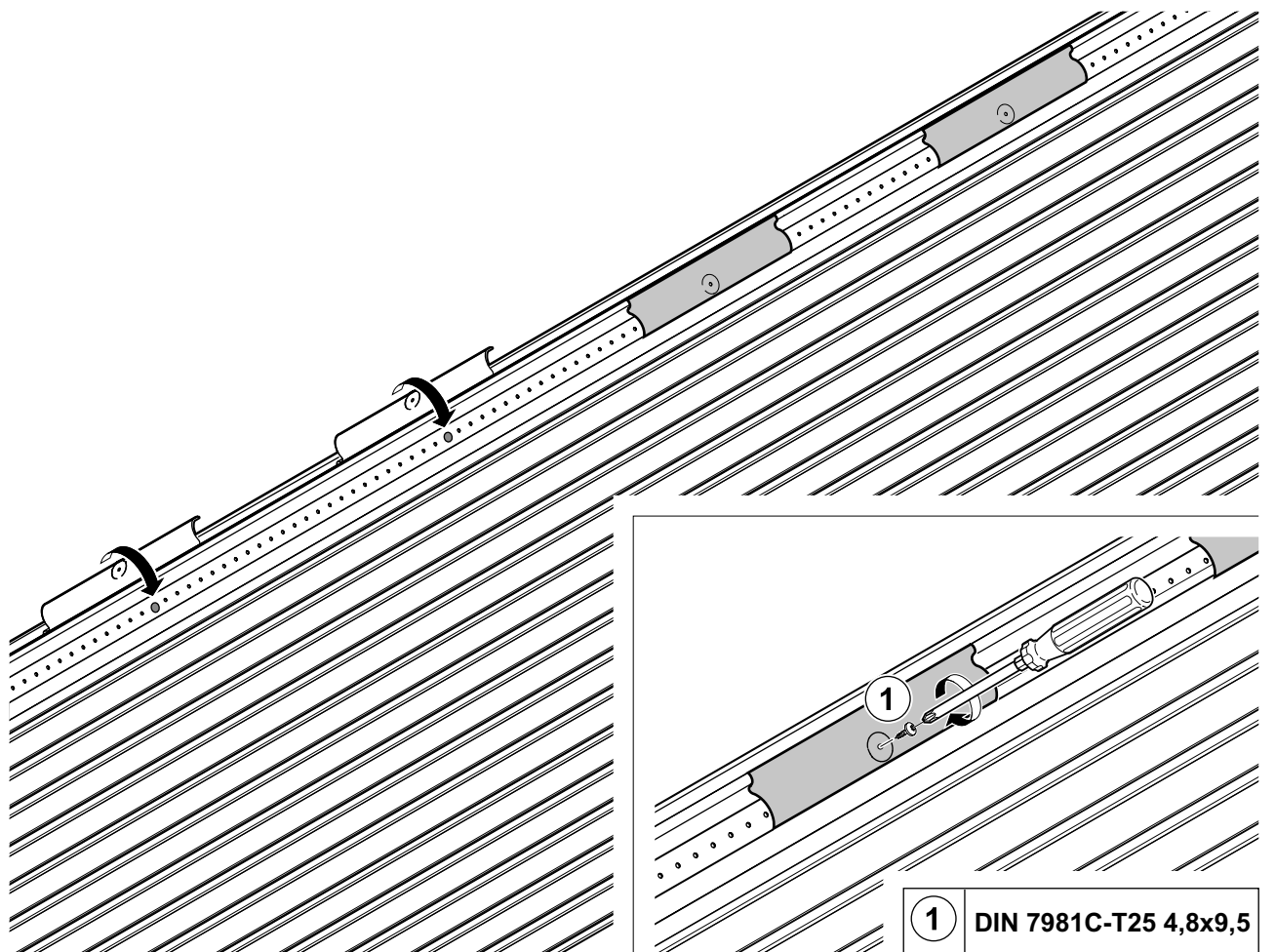
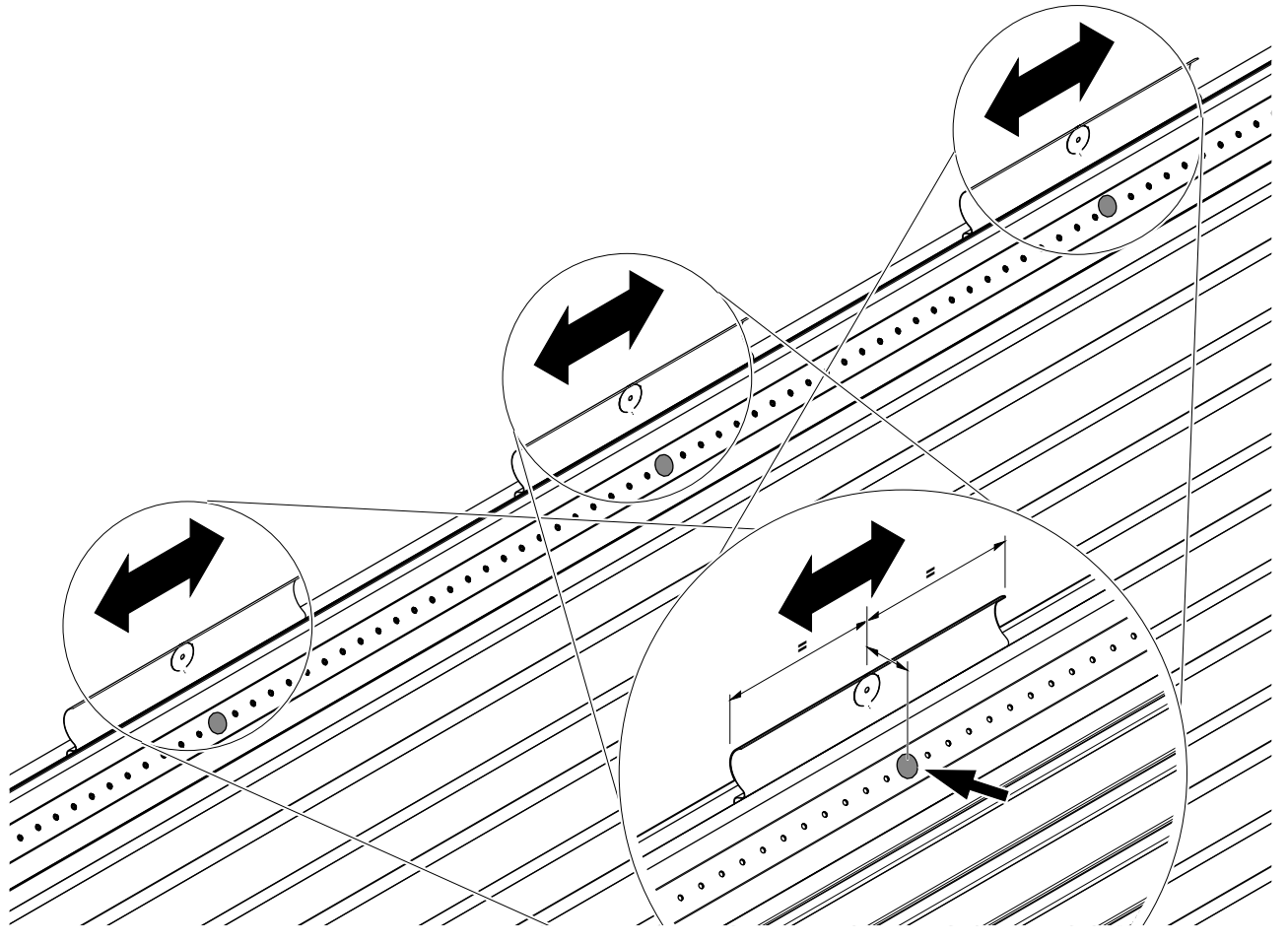

① DIN 7981C-T25 4,8x9,5

3.6

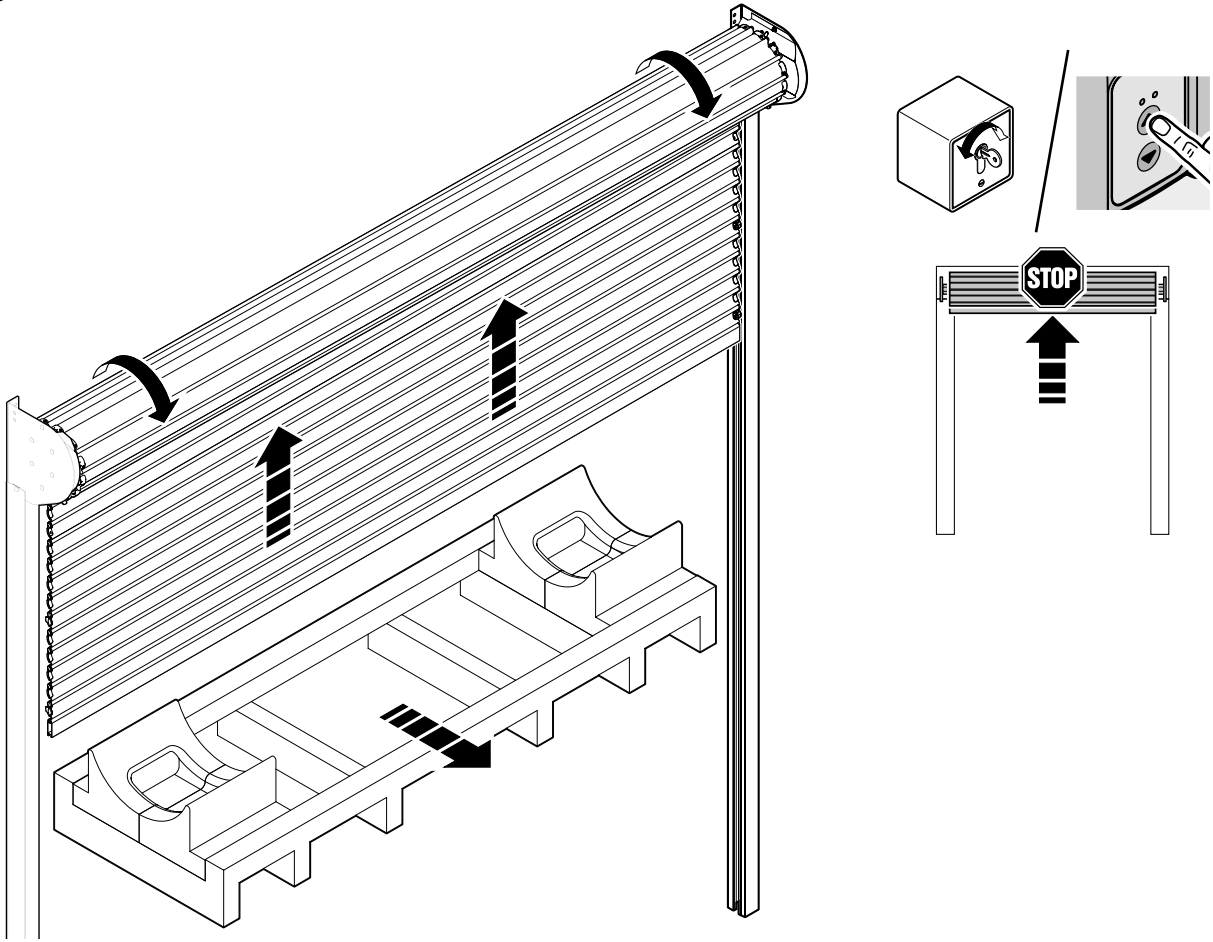

3.7

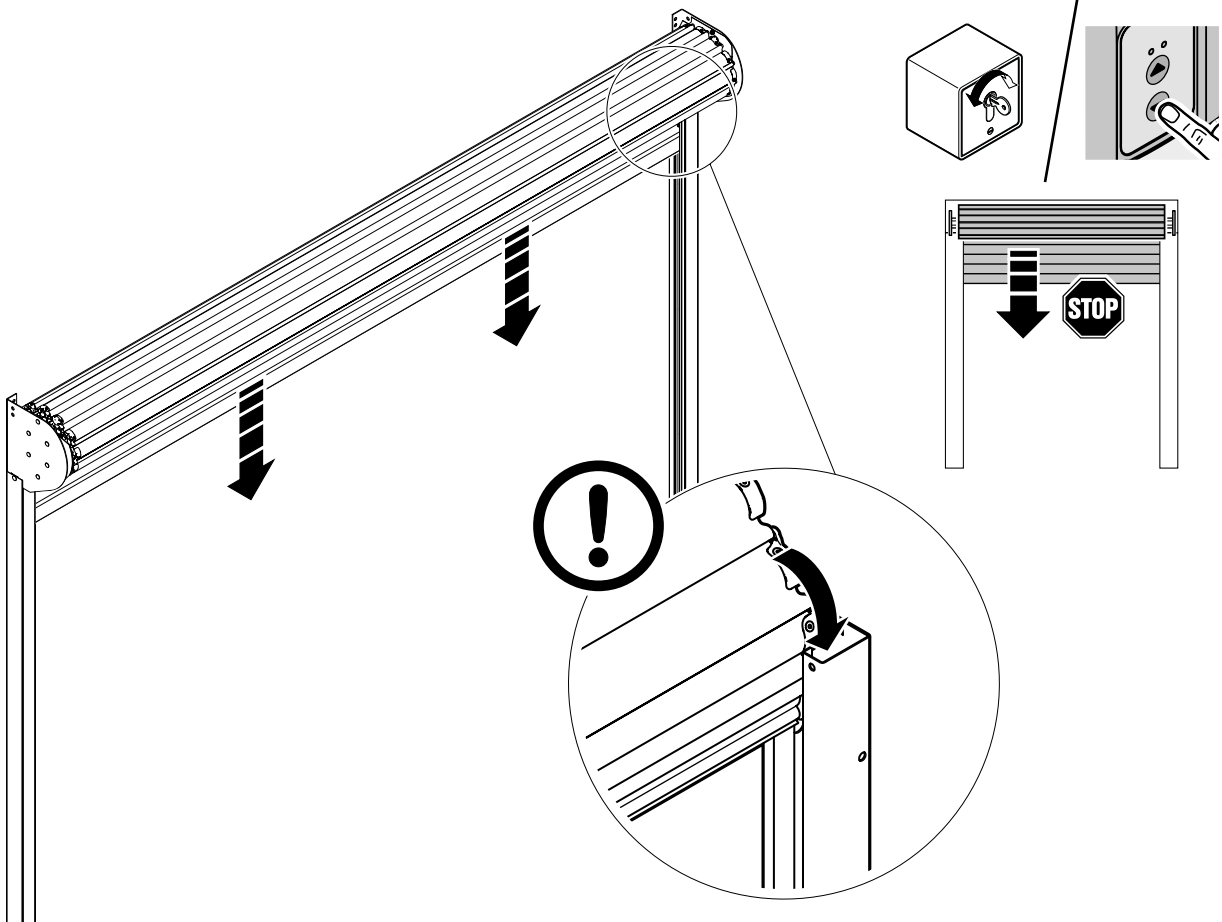

3.8

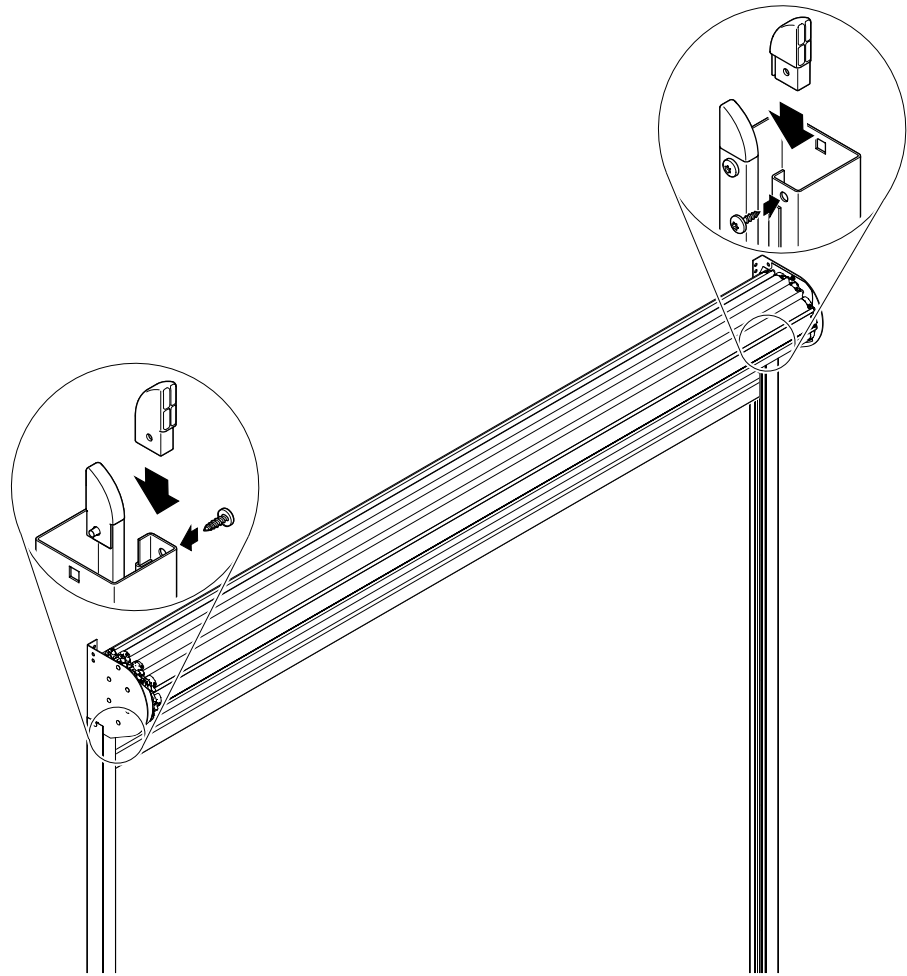

3.9

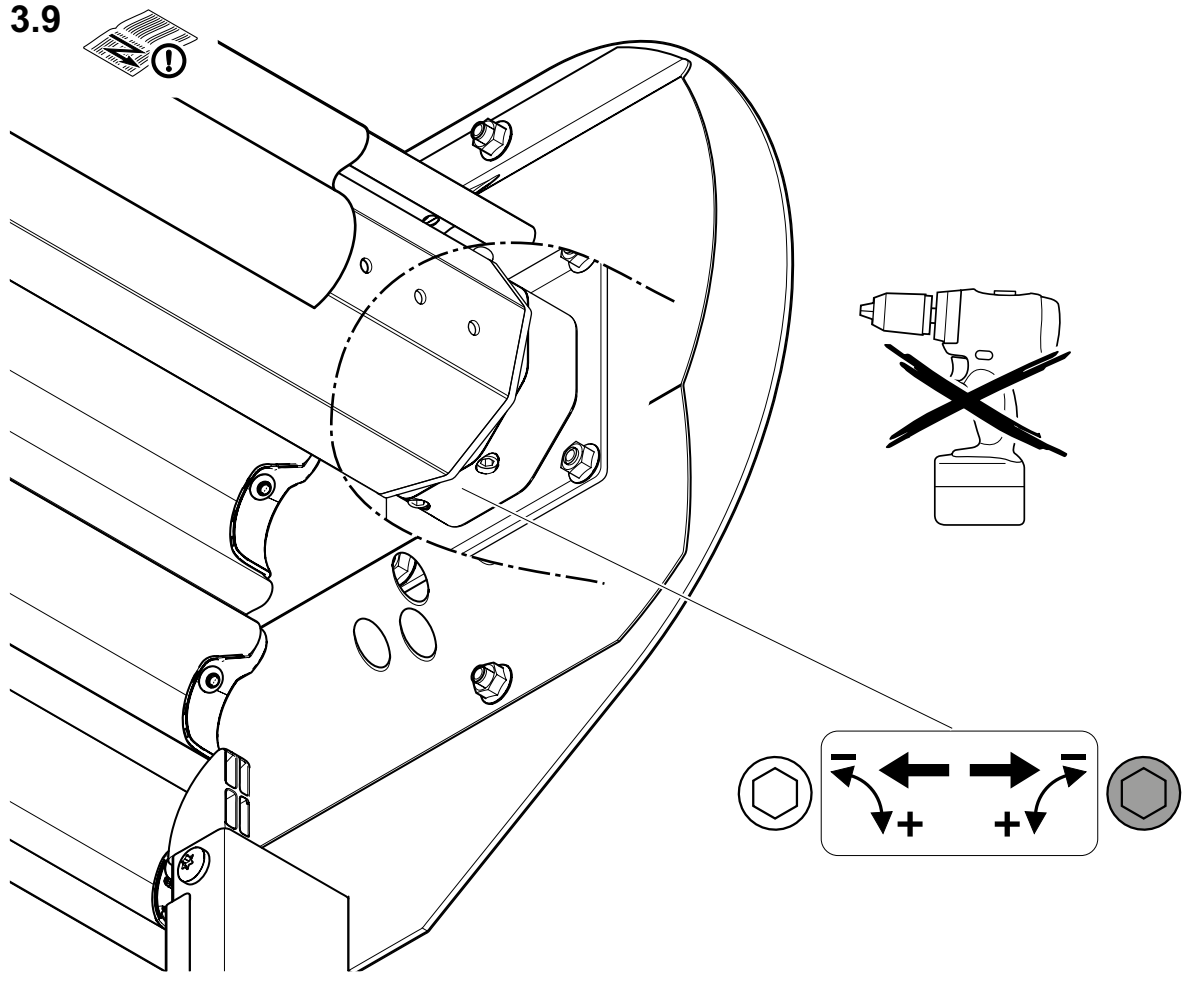

3.10

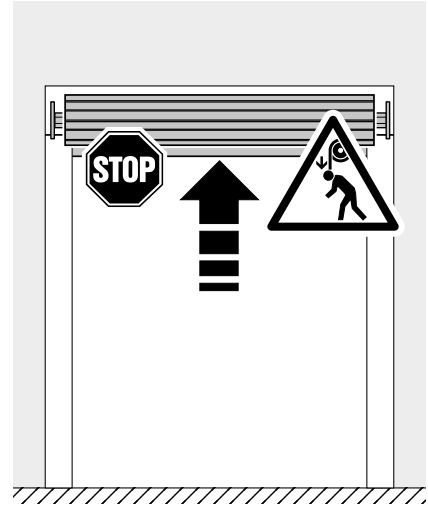
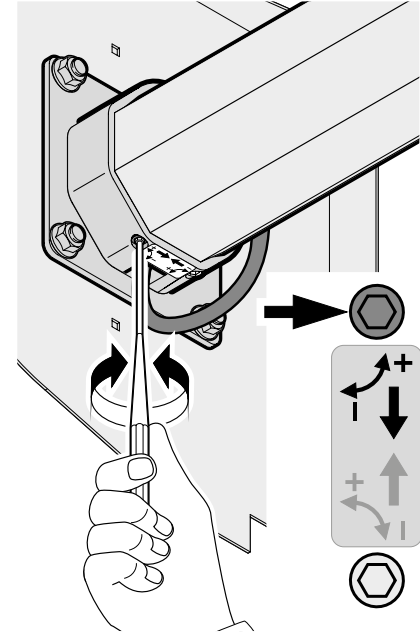
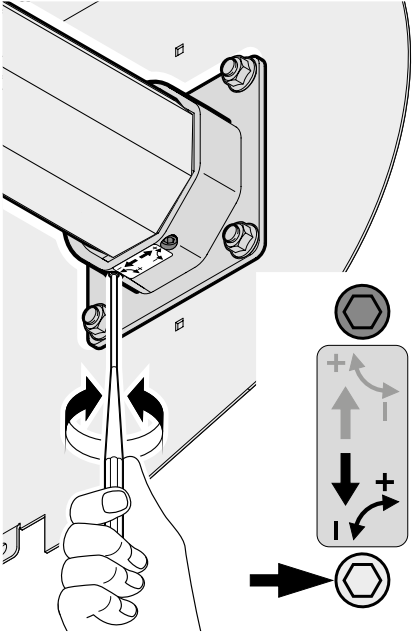
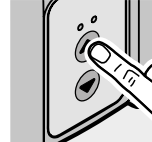
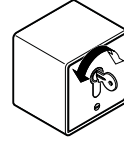
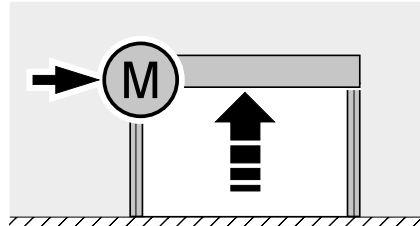
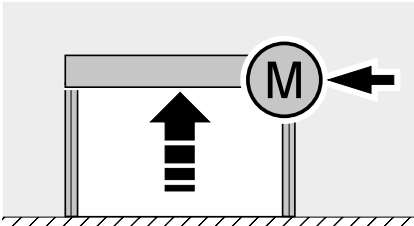

3.11

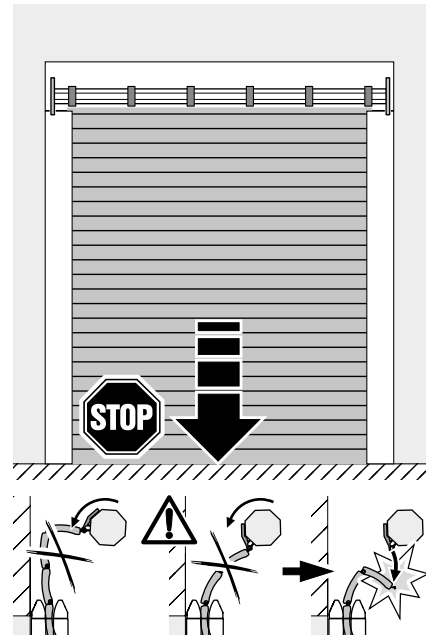
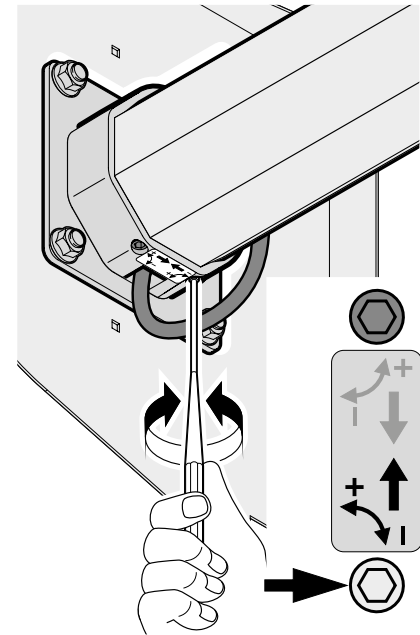
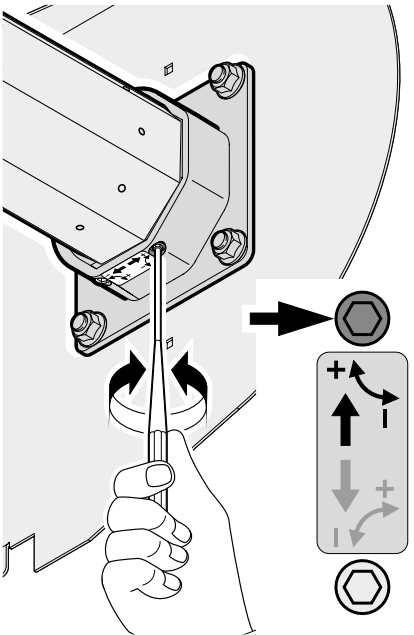
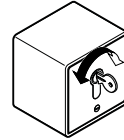
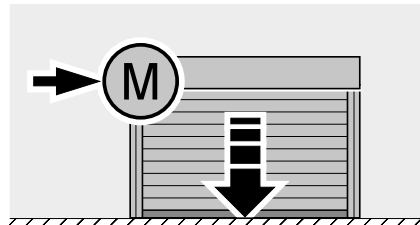
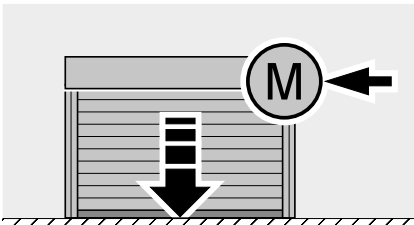

4

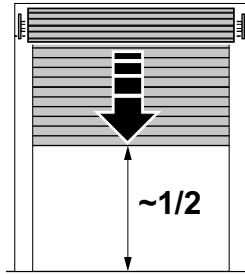
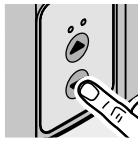
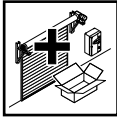

4A.1

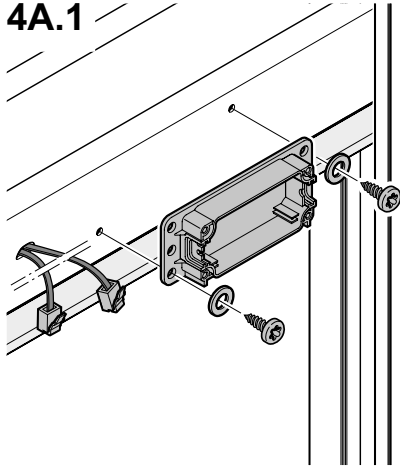

4A.2

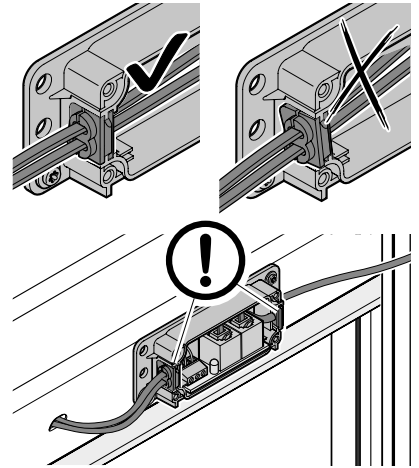
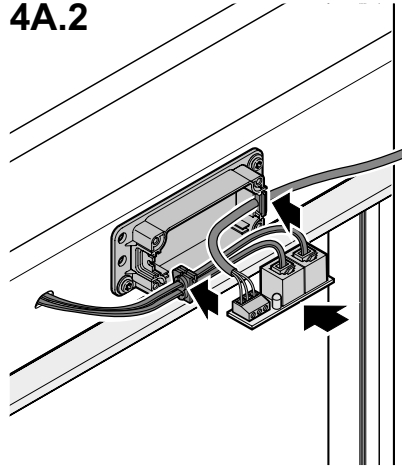

4A.2

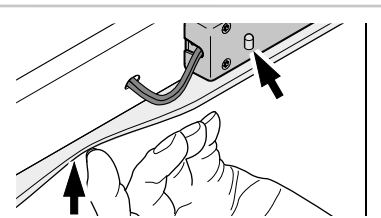
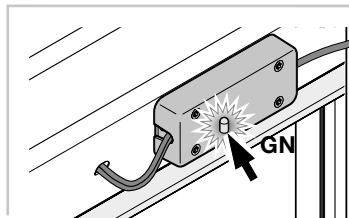
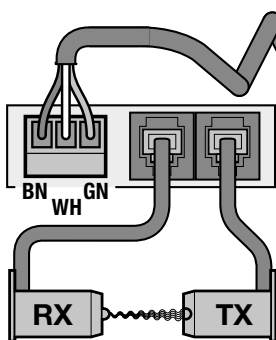
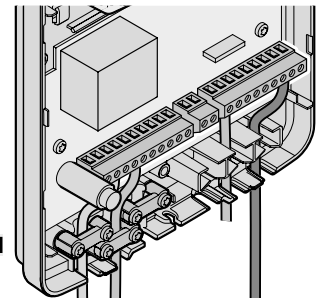
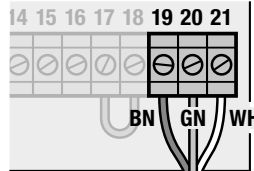
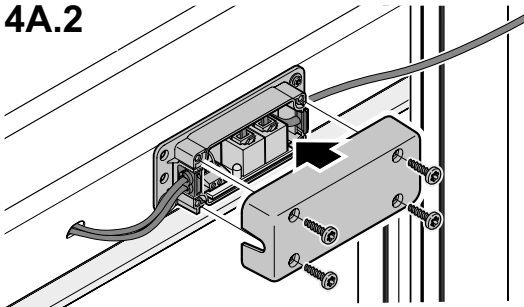

4A.3

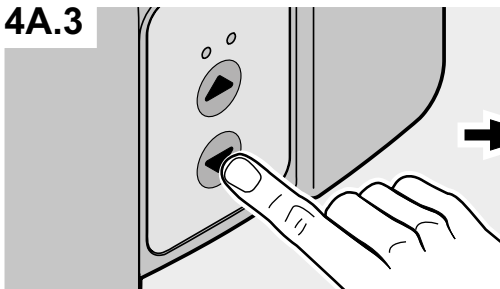

PROGRAMM



4B.1

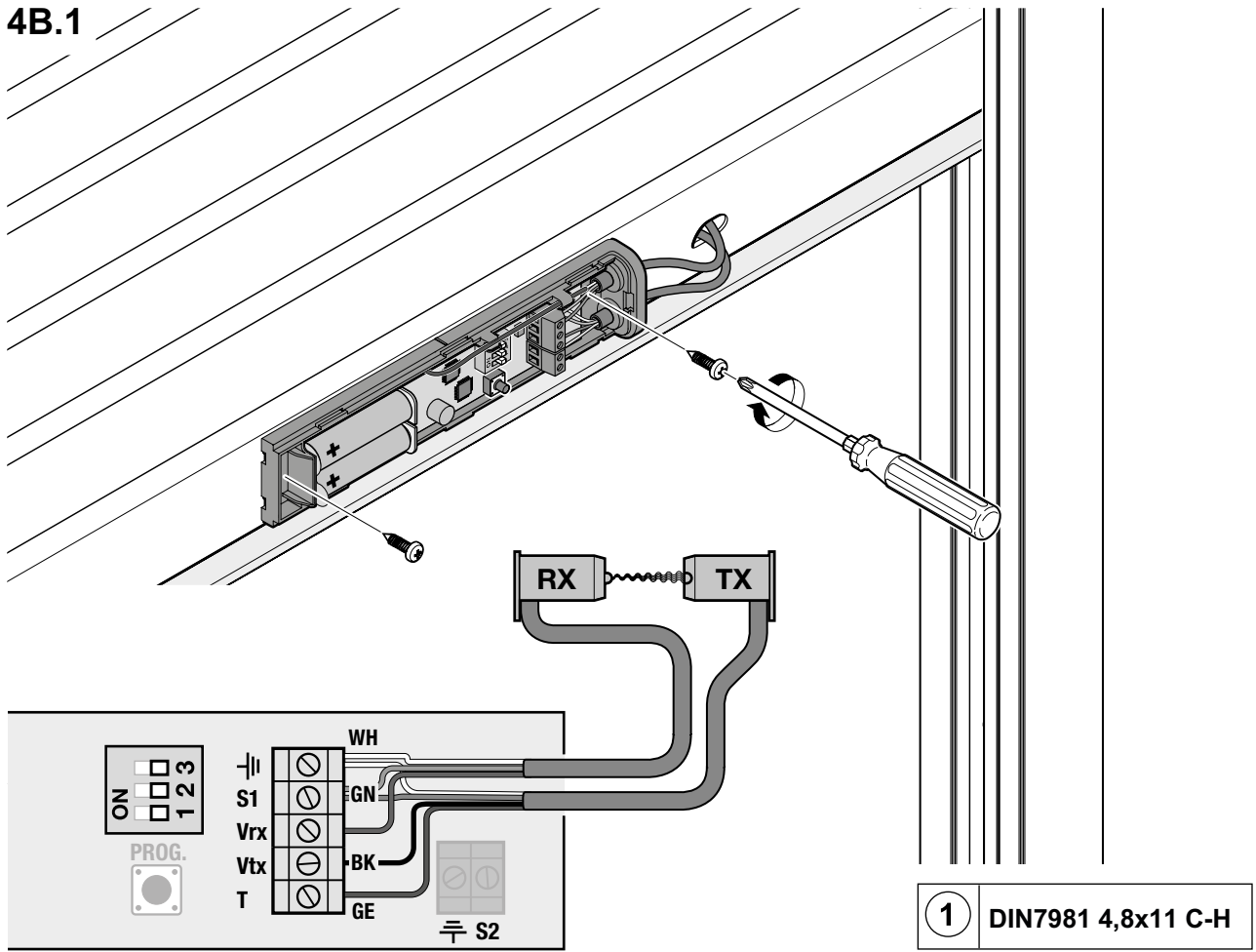

1 DIN7981 4,8x11 C-H

4B.2

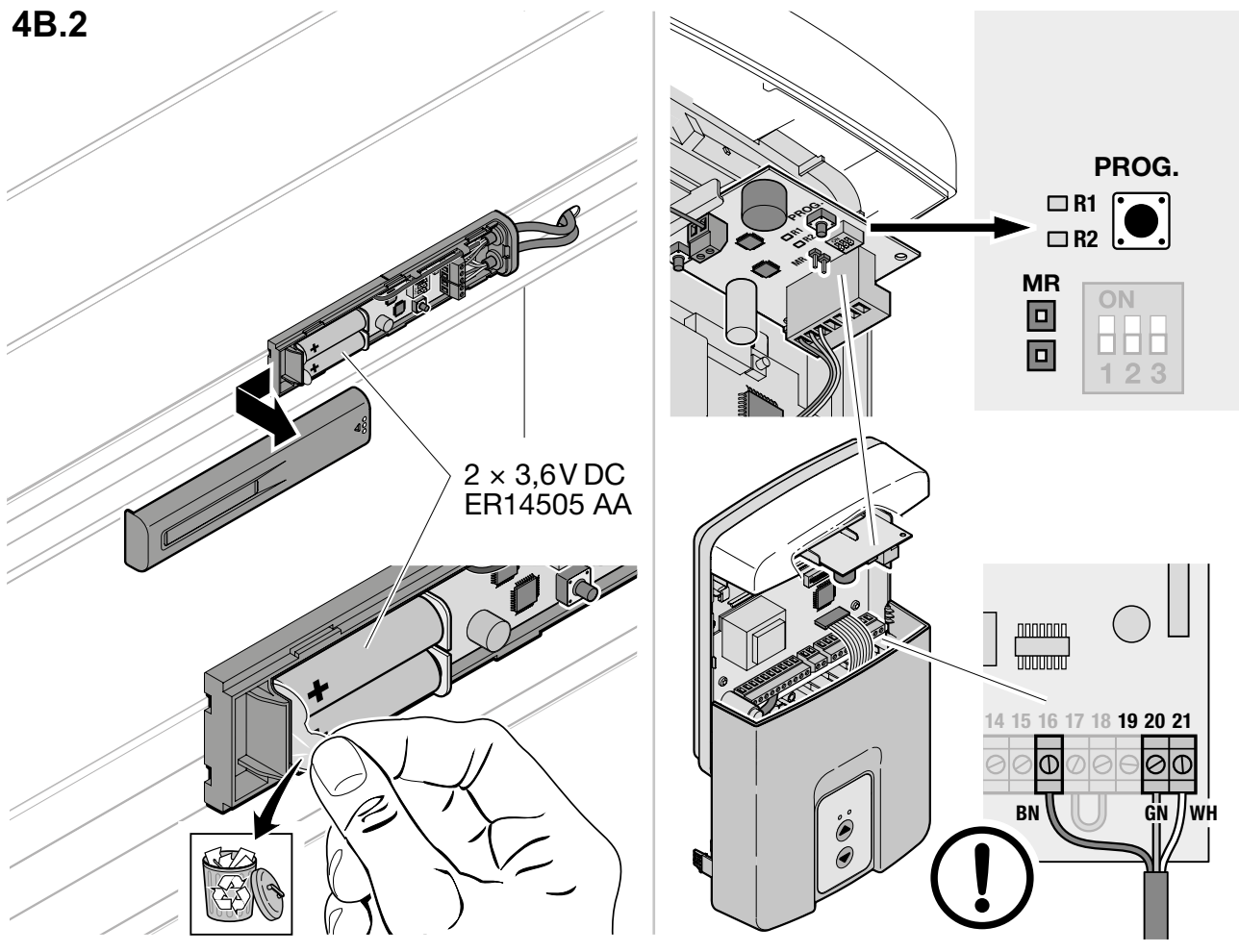

4B.3

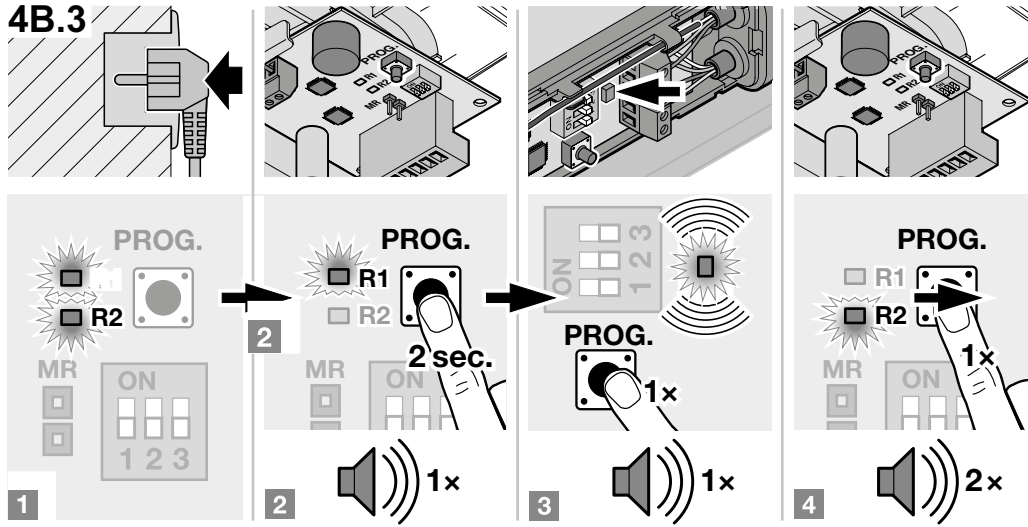

4B.3

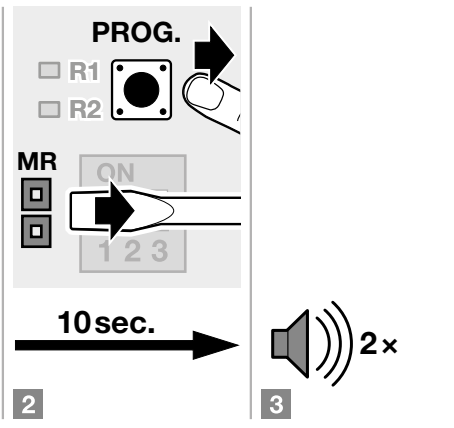
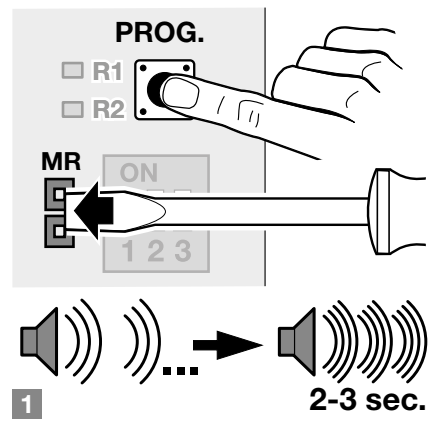
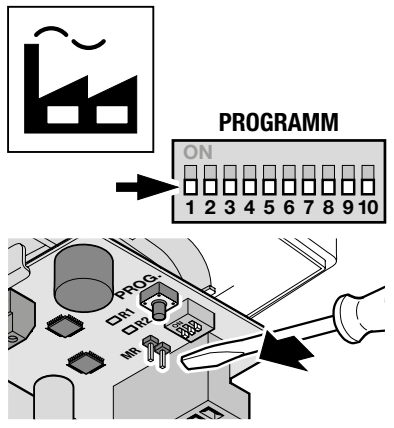
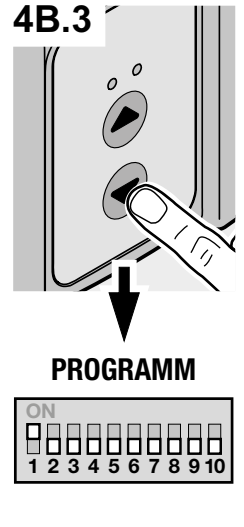

5

868 MHz

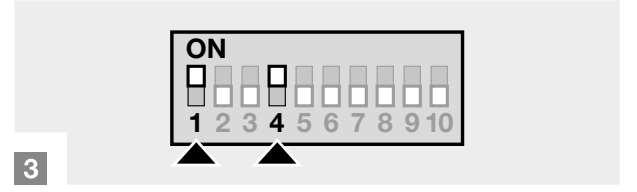
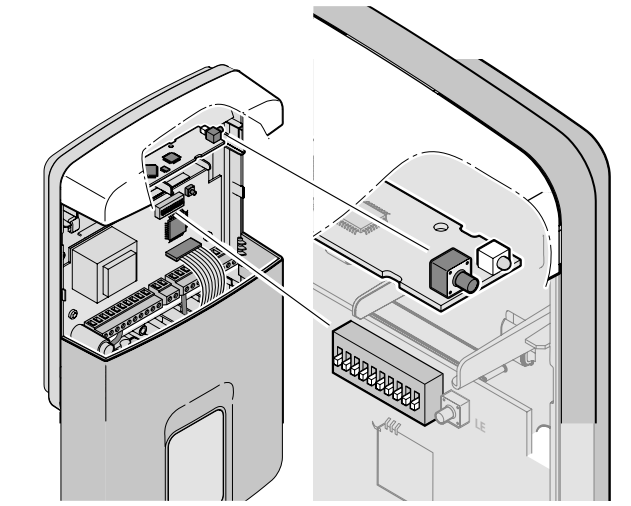
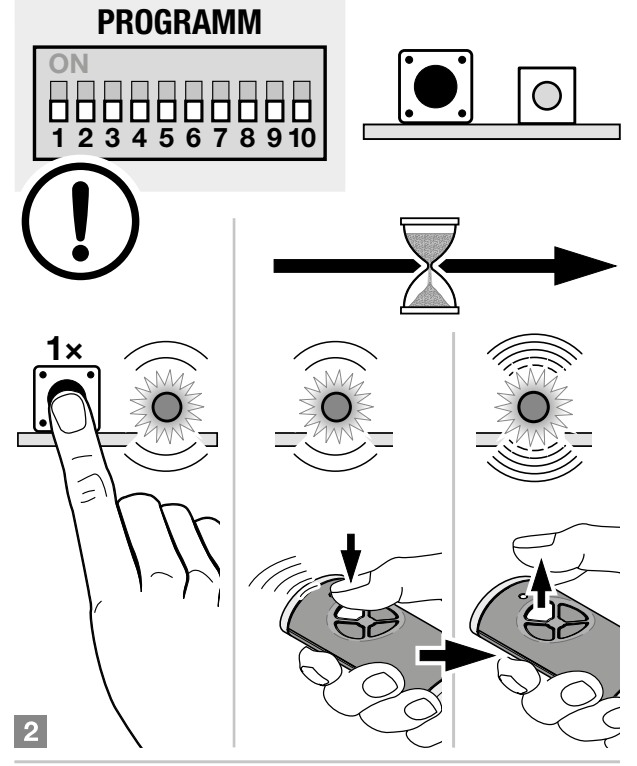
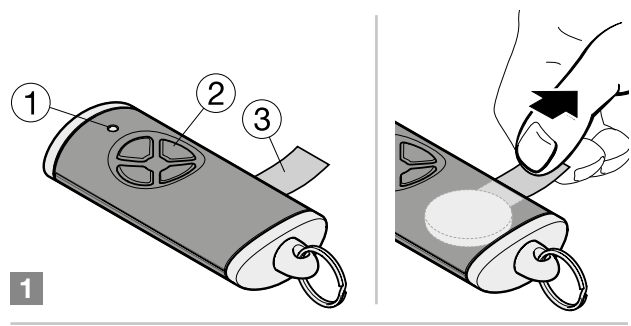

6

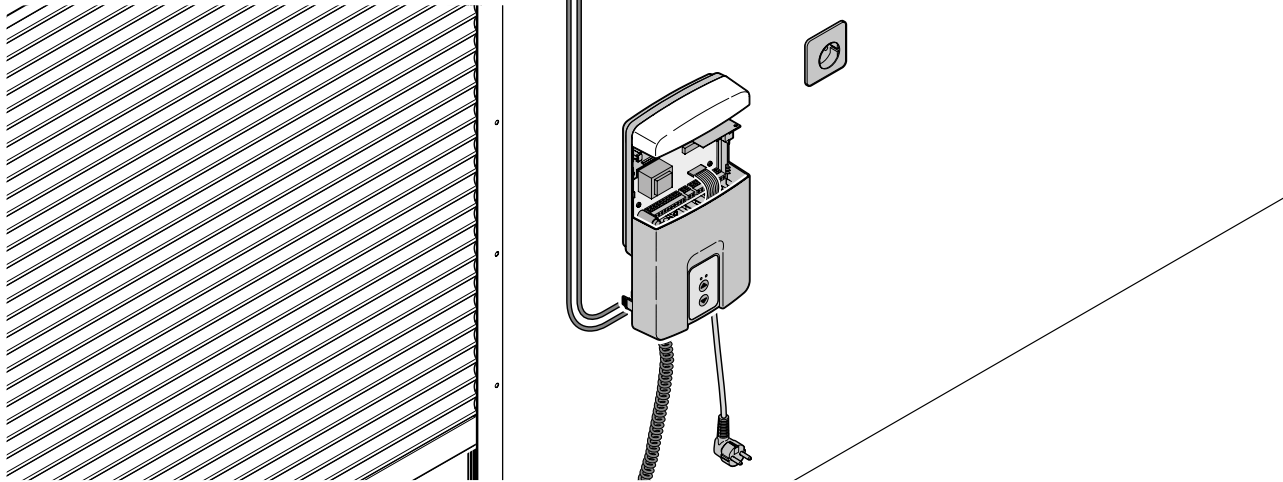
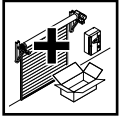

6.1

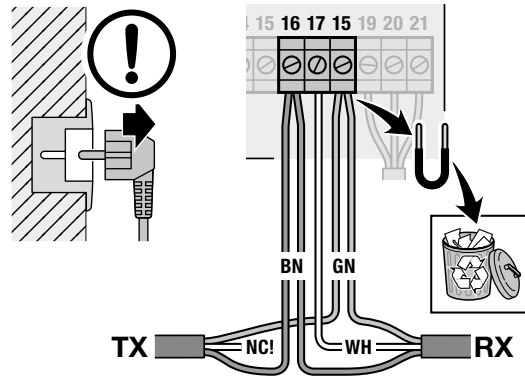
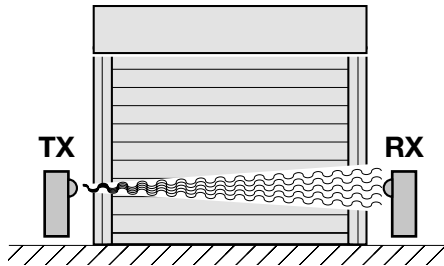
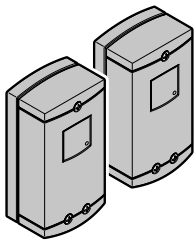

6.2

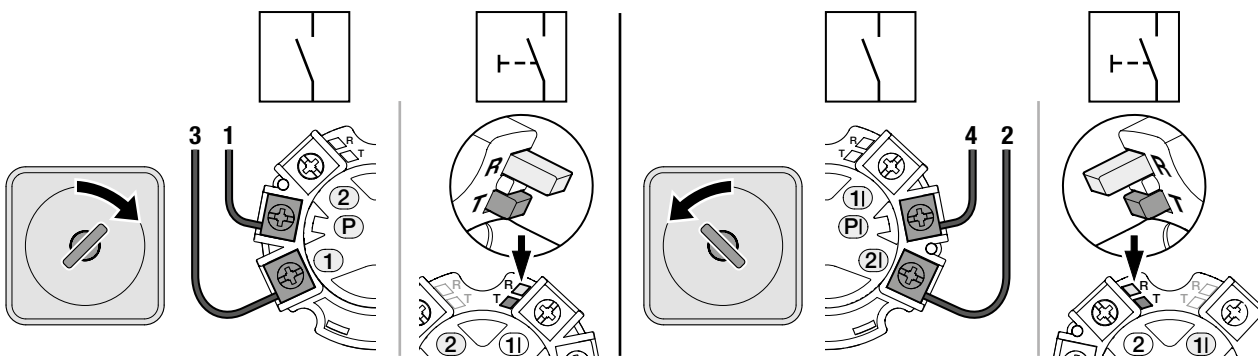
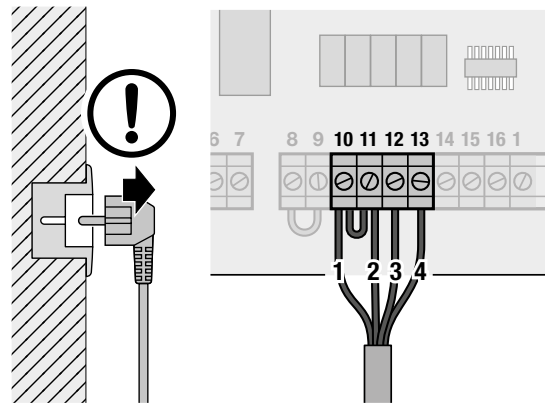
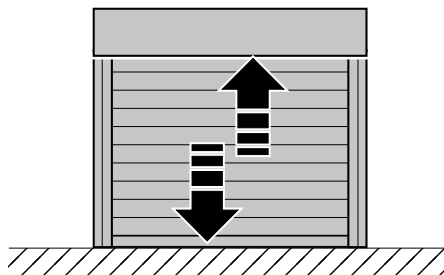
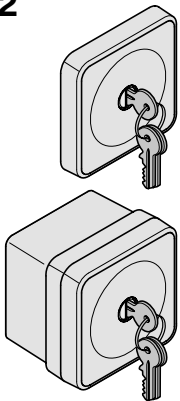

7

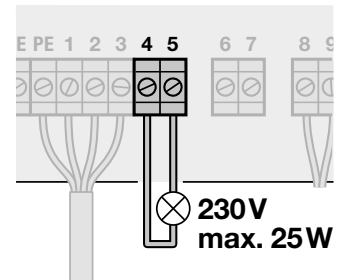
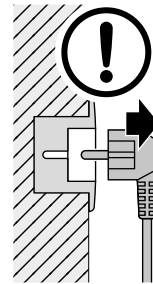
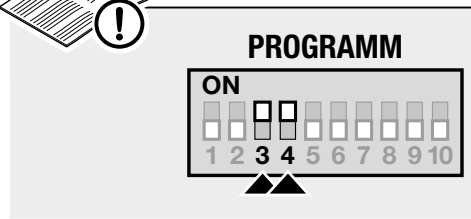
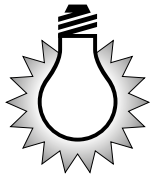
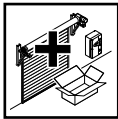

7.1

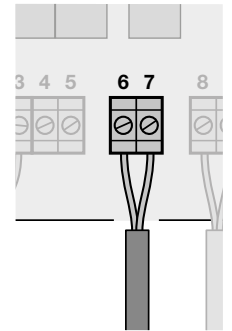
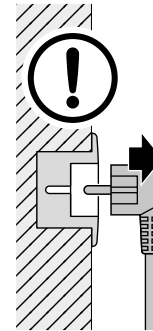
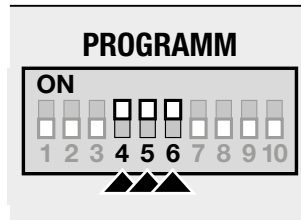
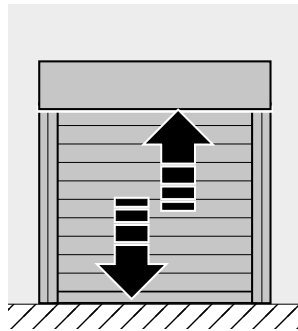

7.2

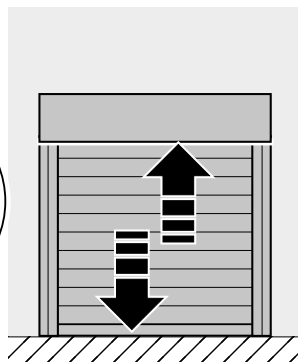
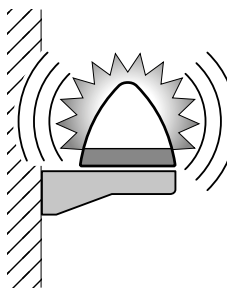

PROGRAMM

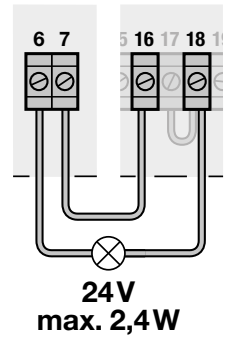
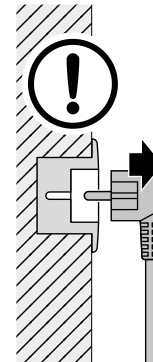
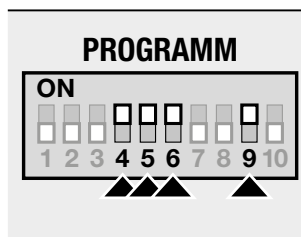

7.3

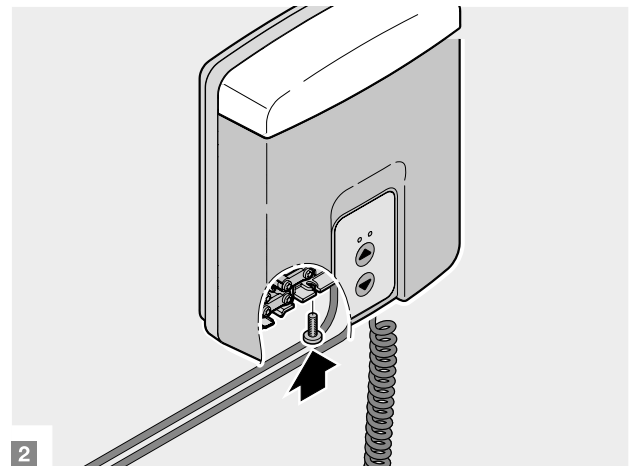
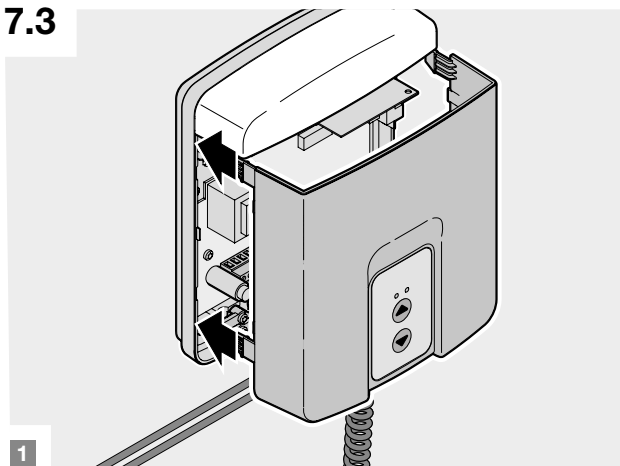

8

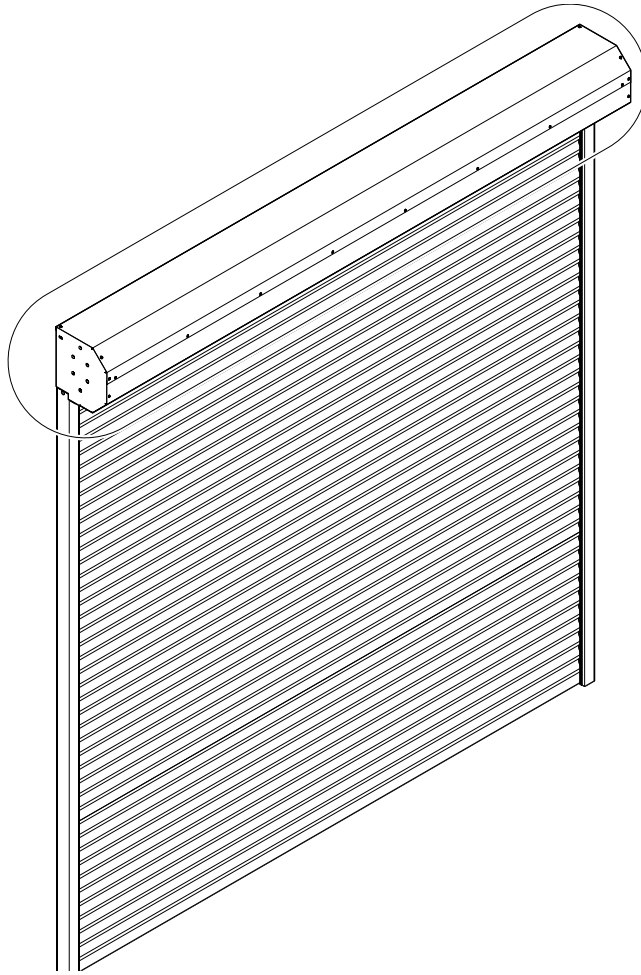

8.1

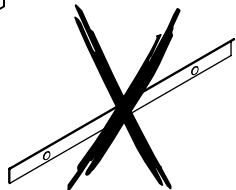
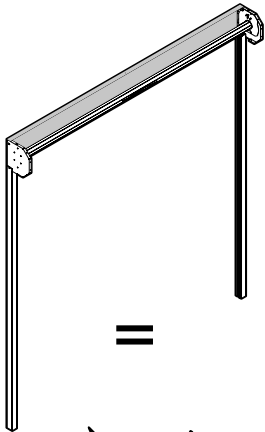

➔ 8.4b

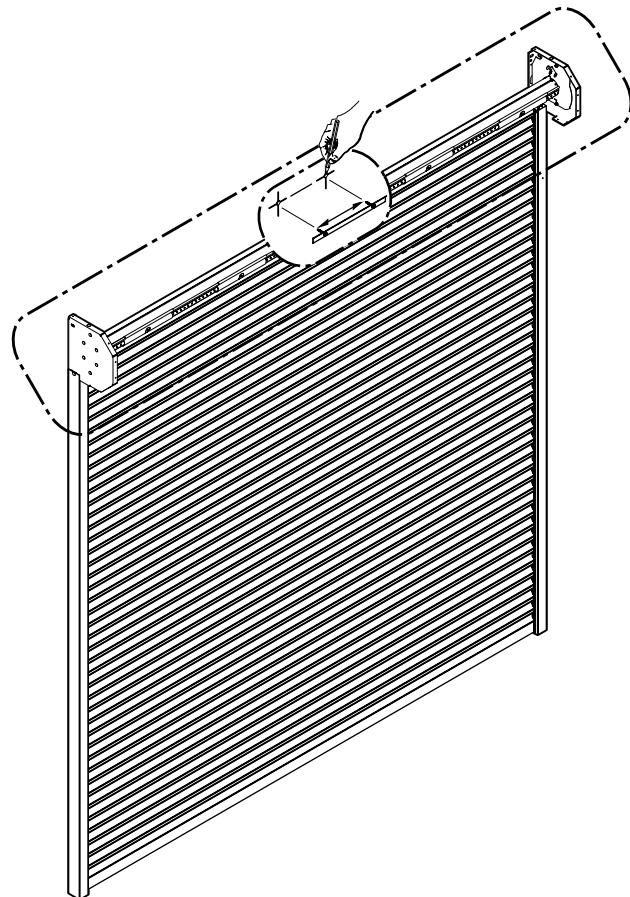

8.2

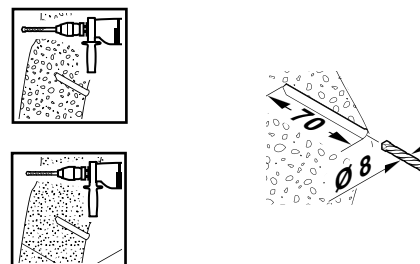
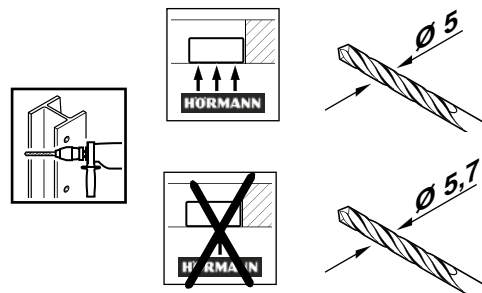
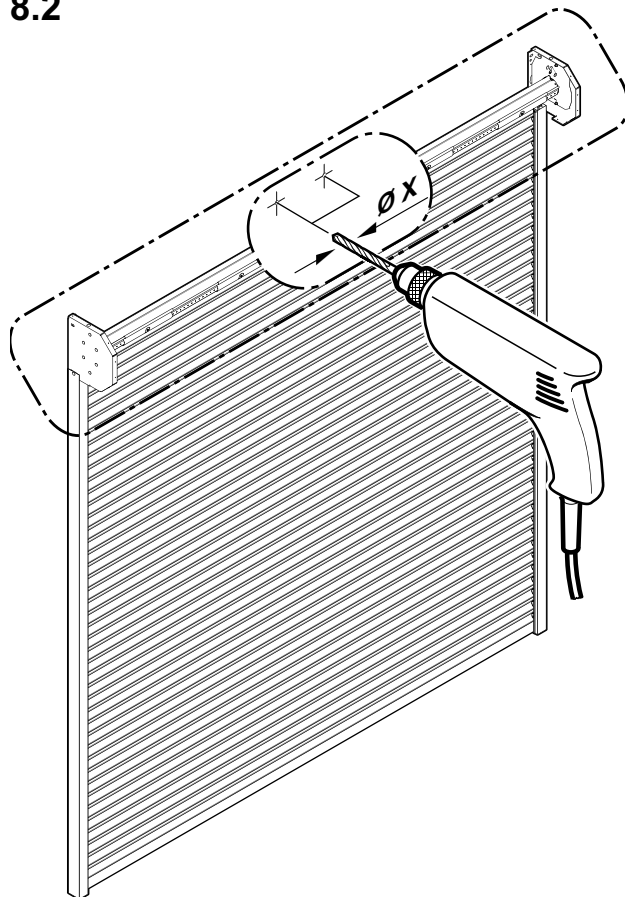

8.3

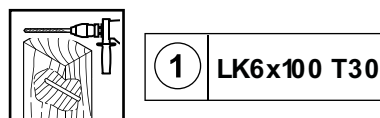
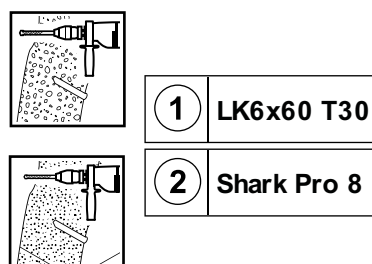
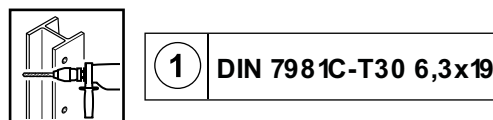
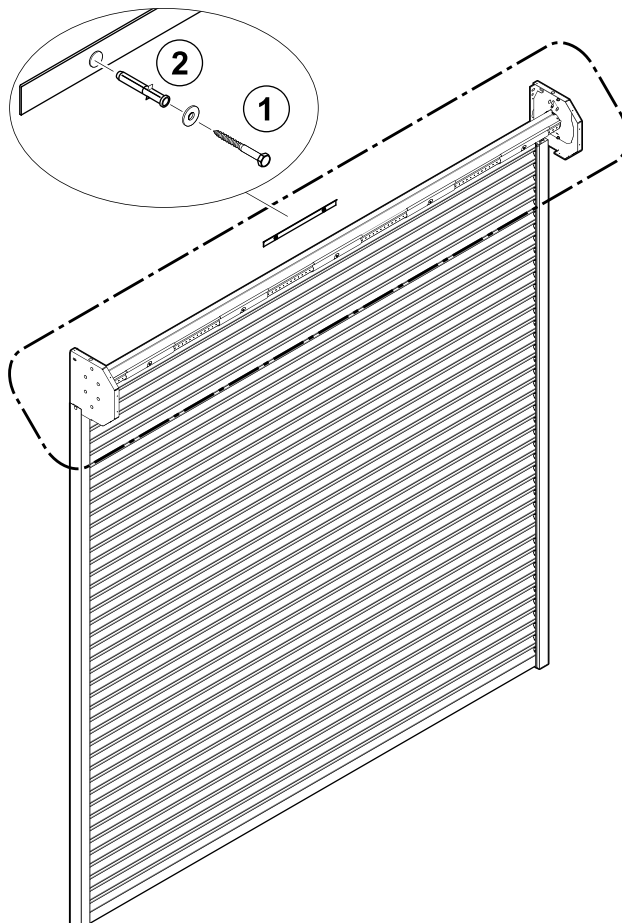

8.4 a

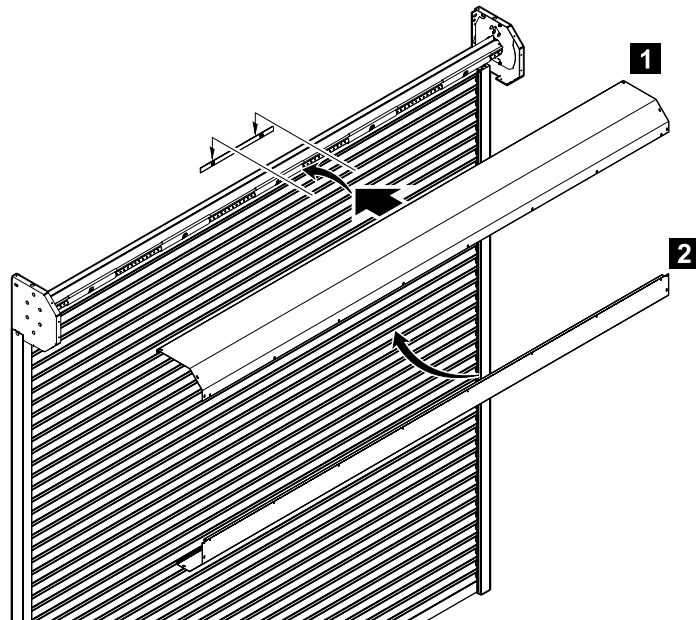

8.4 b

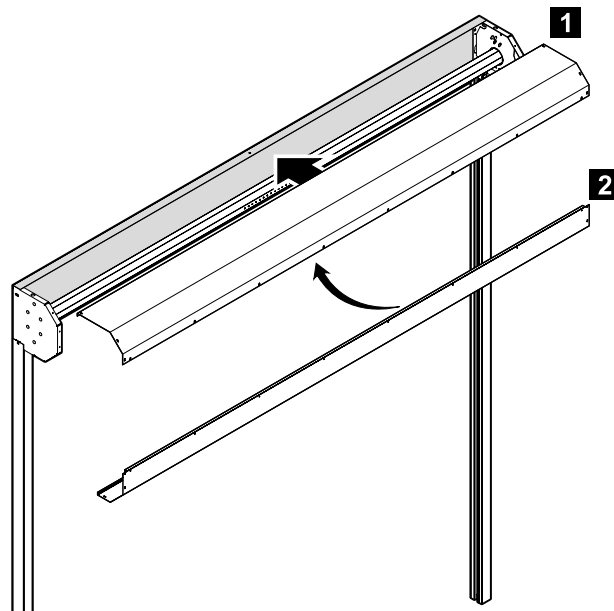

8.5

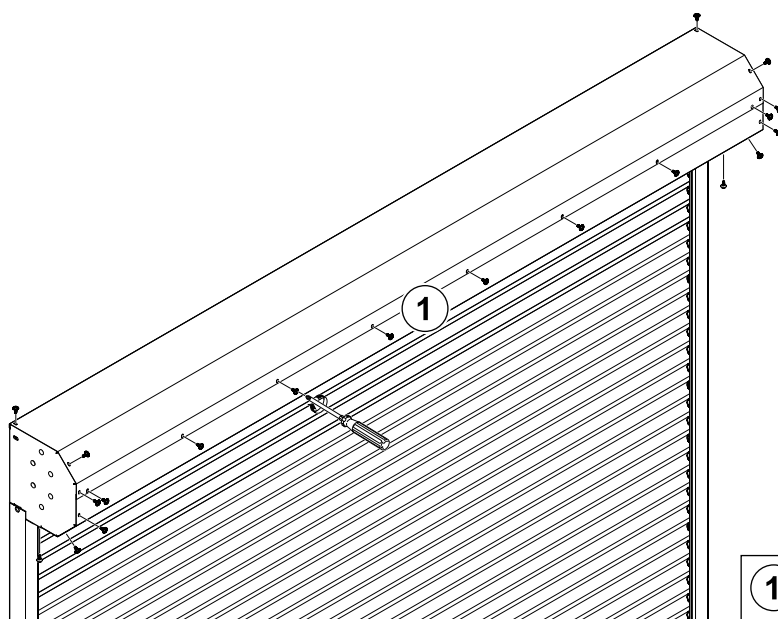

1 DIN7981C-T25 4,8x16

4.4 Control system and control elements

NOTE:

- Only attempt to carry out the electrical installation if you are a qualified electrician or have received adequate instruction from a qualified electrician. More specifically, you must possess the following qualifications:
 - You must recognise the hazards that electricity can cause.
 - You must be familiar with the applicable electrotechnical regulations.
 - You must be able to use and take care of the safety equipment.
 - You know how to give first aid.
- In addition, observe the following instructions:
 - Instructions for installation of electrical connections
 - Instructions for fitting additional electrical control elements
- Make sure that the electrical installation complies with the applicable safety requirements.

ATTENTION
<p>External voltage or lead damage</p> <p>Electronics can be destroyed by external voltage or damage to the connecting cables.</p> <ul style="list-style-type: none"> ▶ Do not apply any external voltage to the connecting terminals of the door system. ▶ Never pull on the connecting cables of the electrical components.

WARNING
<p>Operation with push-to-lock control elements</p> <p>Operating the door system with push-to-lock control elements can lead to serious injuries and damage.</p> <ul style="list-style-type: none"> ▶ Make sure that no push-to-lock control elements are connected to the door system.

ATTENTION
<p>Operation with 2 control elements</p> <p>Operating the door system with 2 control elements that are not changeover switches can damage the door operator.</p> <ul style="list-style-type: none"> ▶ Connect 2 control elements to the door system exclusively as changeover switches.

4.5 Suspended ceilings or obstacles in the lintel area

ATTENTION
<p>Fitting the door system with suspended ceilings or obstacles in the lintel area</p> <p>Slots in suspended ceilings or obstacles in the lintel area can damage the door system if the size or spacing is too small.</p> <ul style="list-style-type: none"> ▶ For trouble-free functioning of the door system with suspended ceilings or obstacles in the lintel area, a free passage with a door width of + 120 mm and a depth of at least 100 mm must be available.

5 Control B100 R

5.1 Setting additional functions via DIL switches

Setup operation / normal operation – DIL switch 1

1 ON	Normal operation/ impulse operation
1 OFF	Setup operation for fitting the door / press-and-hold

Reversing behaviour – DIL switch 2

2 ON	The door reverses into the <i>OPEN</i> end-of-travel position
2 OFF	The door reverses briefly, the obstacle is released

External lighting – DIL switch 3 / DIL switch 4

The external lighting or warning light is set with DIL switch 3 in combination with DIL switch 4. Connect the warning light to option relay 4.

3 OFF	4 OFF	Impulse 2 s after <i>OPEN command</i>
3 ON	4 OFF	Permanent light 2 min. after <i>OPEN command</i>
3 OFF	4 ON	The relay switches slowly during a door run
3 ON	4 ON	Permanent light during the hold-open phase

Door limit switch reporting / pre-warning time – DIL switch 5, DIL switch 6

The functions of option relay 5 are set with DIL switch 5 in combination with DIL switch 6.

5 OFF	6 OFF	CLOSE limit switch reporting
5 ON	6 OFF	<i>OPEN limit switch reporting</i>
5 OFF	6 ON	Pre-warning time: flashing (3 s) before door run
5 ON	6 ON	Pre-warning time: flashing (3 s) with automatic timer

Automatic timer – DIL switch 7

7 ON	After the hold-open phase (30 s), automatic timed closing from the <i>OPEN end-of-travel position</i> . Only with additional photocell
-------------	---

7 OFF 	Not activated, automatic timed closing not possible
--	---

Door maintenance display – DIL switch 8

Activate DIL switch 8. To do this, please follow the instructions in the section *Inspection and maintenance: checking end-of-travel positions*.

8 ON	Activated, permanent flashing light of red LED after more than 2000 door cycles
8 OFF 	Not activated

DIL switch 9 – Additional function of option relay 5

9 OFF 	Not activated
9 ON	Permanent flashing light during door run Only with additional LED warning light

DIL switch 10

10 ON	Operator with electronic limit switch
10 OFF 	Operator with mechanical limit switch

5.2 Funk

5.2.1 Hand transmitter

 WARNING	
Danger of injury during door travel	
Using the hand transmitter can cause injury to people by triggering door travel.	
▶	Make sure that the hand transmitter is kept away from children! Only persons who have been instructed in the function of the remote-controlled door system may use the hand transmitter.
▶	If the door has only 1 safety device, only operate the hand transmitter with visual contact to the door.
▶	Only drive or pass through remote-controlled door systems if the door is in the <i>OPEN</i> end-of-travel position.
▶	An unwanted door run may occur if a hand transmitter button is accidentally pressed (e.g. if stored in a pocket / handbag).

 CAUTION	
Danger of injuries due to unintended door travel	
An unwanted door run may occur during the teach-in process on the radio system.	
▶	When teaching in the radio system, no persons, in particular children, or objects may be within the door's area of travel.

ATTENTION	
Functional impairment caused by environmental effects	
Non-compliance with these instructions can impair the function!	

Protect the hand transmitter from the following conditions:
<ul style="list-style-type: none"> • Direct sunlight (permissible ambient temperature: -20°C to +60°C) • Moisture • Dust

NOTES

- After programming or extending the radio system, carry out a function check.
- Only use original components when putting the radio system into service or extending it.
- Local conditions may affect the range of the radio system.

The hand transmitter works with a rolling code that changes with each sending procedure. You must teach in the hand transmitter with the desired hand transmitter button on each receiver that you want to control.

5.2.1.1 control elements

- 1 LED 2 Hand transmitter buttons 3 Battery

5.2.1.2 Hand transmitter LED signals

- **The LED illuminates:**
The hand transmitter is sending a radio code.
- **The LED flashes:**
The hand transmitter is still transmitting, but the battery is too weak. Replace the battery.
- **The LED is not illuminated:**
The hand transmitter is not functioning.
 - Check whether the battery has been inserted correctly.
 - Replace the battery with a new one.

5.2.1.3 Excerpt from the declaration of conformity

Conformity of the abovementioned product with the requirements of the Radio Equipment Directive (RED) 2014/53/EU was verified by compliance with the following standards:

- EN 300 220-3
- EN 301 489-1
- EN 300 489-3

You can request the original declaration of conformity from the manufacturer.

5.2.2 Integrated radio module

With an integrated radio module, you can teach in 6 hand transmitter buttons each for the impulse functions (Open, Stop, Close, Stop). If more than 6 hand transmitter buttons are taught in per function, the function is deleted from the hand transmitter button that was taught in first.

The following conditions must be met to program the radio module or delete its data:

- The pre-warning or hold-open phase is not active.

NOTES

- To operate the operator with radio, you must teach in a hand transmitter button on an integrated radio module.

5.2.2.1 Teaching in the hand transmitter buttons for an integrated radio module:

1. Press the **TEACH** circuit board button 1 × briefly. Availability of radio programming is immediately stopped if the **TEACH** circuit board button is pressed again. The **GE** LED flashes. During this time, you can program a hand transmitter button for the desired function.
2. Keep the hand transmitter button you want to teach in pressed until the yellow LED flashes quickly.
3. Release the hand transmitter button. Press the hand transmitter button again within 15 seconds until the LED begins flashing very rapidly.
4. Release the hand transmitter button. The yellow LED will be illuminated. The hand transmitter button has been taught in and is now ready for operation.

5.2.2.2 Deleting all data in an integrated radio module

1. Press and hold the **TEACH** circuit board button. The **GE** LED flashes slowly and signals availability for deletion. The flashing then becomes more rapid. All taught-in radio codes of all hand transmitters have now been deleted.
2. Release the **TEACH** circuit board button.

5.2.3 Single plate mode

Operation via cover keypad:

1. Push of a button: Door runs in the direction of the arrow
2. Push of a button: Door stops
3. Push of a button: Door runs in the direction of the arrow

Operation with the hand transmitter:

The hand transmitter works exclusively with impulse sequence control.

1. Impulse: The door runs towards an end-of-travel position.
2. Impulse: The door stops.
3. Impulse: The door runs in the opposite direction.
4. Impulse: The door stops.
5. Impulse: The door runs in the direction of the end-of-travel position selected in the 1st impulse

6 Initial start-up

6.1 End-of-travel positions

The door's end-of-travel positions are set at the operator.

NOTE:

Follow the instructions in the illustrated section.

Set the end-of-travel positions as follows:

CLOSE end-of-travel position

- The bottom profile contacts the floor along the full length
- Max. 5 profiles have travelled into one another
- The rolling grille curtain does not bulge out and hangs straight down.

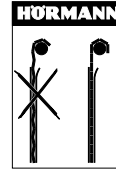

Make sure that no more than 5 profiles travel into one another, otherwise the following problems may occur:

- The door will produce increased noise on opening.
- The closed door is unstable and tends to rattle under heavy wind loads.

WARNING

Exceeding the CLOSE end-of-travel position

If the door travels beyond the CLOSE end-of-travel position, there is a risk that the connection between the door curtain and barrel will be damaged, causing the curtain to fall off the barrel. There is a danger of injury and damage to the door system.

- ▶ Set the CLOSE end-of-travel position according to the specifications.

OPEN end-of-travel position

The distance from the FFL to the bottom edge of the bottom profile corresponds to the door height in the data label.

WARNING

Exceeding the OPEN end-of-travel position

If the door travels beyond the OPEN end-of-travel position, there is a risk of the door curtain slipping out of the guide rails and sustaining damage. There is also a danger of injury and of damage to the door system.

- ▶ Set the OPEN end-of-travel position according to the specifications.

6.2 Test run

After fitting is complete, test the functional safety in accordance with the inspection plan (see 8 *Inspection and maintenance on page 45*).

Verify in the test log book (dated and signed) that a test run has been successfully completed.

On completing fitting, a test run and the inspection, hand the entire door documentation over to the owner of the door system.

7 Operation

7.1 Safety instructions for door operation

NOTE:

As the operator or owner of the door system, you are responsible for ensuring that all applicable regulations are observed and complied with. You can find the applicable regulations in section 1.2 *Standards and directives to be observed on page 2*.

⚠ CAUTION

Danger of injury due to incorrect handling of door system
 Handling the door system incorrectly can lead to injury. Observe the following safety instructions.

- ▶ You are responsible for ensuring that only suitably instructed persons operate the door. A person is considered instructed if he / she fulfills the following criteria:
 - He / she has been shown how to operate the door safely.
 - He / she has received permission from you to use the door system.
- ▶ You are responsible for ensuring that children cannot operate the door system.
- ▶ Wait until the door has come to a standstill before walking / driving into the door system's area of travel.
- ▶ Never use the door to lift objects and / or persons.
- ▶ Before walking / driving into the door's area of travel, always check that the door curtain has travelled up far enough to provide the necessary passage height.
- ▶ Only ever operate the door system when all the protective devices and safety equipment are fitted and are in perfect working order.
- ▶ Do not dismantle or alter any of the protective devices. Do not put any of the protective devices out of operation.

ATTENTION

Damage due to incorrect handling of the door system
 Handling the door system incorrectly can lead to damage to the door system. Observe the following safety instructions.

- ▶ Protect the door from aggressive and caustic substances, such as:
 - Nitrous acid action from stone or concrete
 - Cement, plaster
 - Acids, alkali
 - Road salt
 - Coatings / paint with an aggressive action
 - Sealants with an aggressive action

NOTE:
 Make sure you are familiar with the way the control elements and the operator work (see instructions).

7.2 Emergency stop

Proceed as follows during emergency-stop situations for doors with operator:

- ▶ Disconnect the mains plug from the mains.
or
- ▶ Actuate the red main switch or the emergency stop button.

7.3 Emergency operation in case of operator malfunction

If the operator malfunctions or fails, you can manually open and close the door in emergency operation. Hang the supplied crank handle into the eyelet on the operator or

insert the crank handle into the opening provided through the building structure. Turn the crank handle to move the curtain in the desired direction.

⚠ CAUTION

Danger of injury due to too high opening of the door curtain
 If the door curtain is opened too high with the crank handle, the curtain may slide out of the side guides and cause injury.
 Observe the following safety instructions:

- ▶ Crank the bottom edge of the curtain to a maximum of 100 mm below the top ends of the side guides.

⚠ CAUTION

Changing the end-of-travel positions using the crank handle
 The end-of-travel positions of the door system can be maladjusted when using the crank handle. The curtain may slide out of the side guides and cause injury.
 Observe the following safety instructions:

- ▶ After each use of the crank handle, check the end-of-travel positions of the door system and readjust them if necessary.

7.4 Operating conditions

The door system is intended for the following operating conditions:

Temperature range:	–10 °C to 40 °C
Relative humidity:	0% to 60%
Cycles per hour	1
Cycles per day	3

7.5 Wind load

ATTENTION

Damage to the door system due to wind load
 The door curtain deflects under wind loads.
 Door function is not guaranteed and door parts may be damaged during heavy wind loads.

- ▶ Never open or close the door during a wind force exceeding 8 Beaufort.

The following conditions may arise due to high wind loads:

- The door curtain can deform permanently.
- The door construction can suffer damage.

After a heavy wind load, check the operational safety of the door system (see section 8.2 Malfunctions and damage remedy on page 45).

7.6 Information on the product characteristics

7.6.1 Abrasion and pressure marks

The design of the door system represents state-of-the-art technology. Pressure marks and abrasive wear, particularly on the top profiles, are design-related and cannot be avoided.

- ▶ In order to avoid excessive abrasion, remove any soiling (e.g. sand, dust, plastic particles etc.) at regular intervals.

NOTE:

Follow the directions for door cleaning and care (see section 9 *Cleaning and care on page 47*).

7.6.2 Noise

Opening and closing the door produces a certain degree of noise related to the design.

Increased noise emission could occur under the following conditions:

- Extensive soiling of the door curtain (see section 9 *Cleaning and care on page 47*)
- Incorrectly fitted door system

7.7 Accessories

7.7.1 lock lath

ATTENTION

Damage to the door system when operated with locked lock lath

If the door system is operated with the lock lath locked, the operator may overheat and be damaged due to overloading.

- ▶ Do not operate the door system when the lock lath is locked.

7.7.2 Front side emergency operation

Keep the crank handle close to the door.

8 Inspection and maintenance

8.1 Obligation to inspect and maintain

NOTE:

As the owner or operator of the door system, you must have the door inspected and maintained by a specialist (competent person in acc. with EN 12635) once a year.

CAUTION

Ignoring the obligation to inspect and maintain

The following problems may occur if you do not have the door inspected and maintained as specified:

- Risk of injury
- Risk of damage
- Nullification of the warranty

- ▶ Arrange for all the inspections and maintenance work to be carried out by a specialist company.

8.2 Malfunctions and damage remedy

In the case of malfunctions call in a qualified specialist (competent person in accordance with EN 12635) immediately to inspect and repair the door system.

8.3 Original spare parts

Only use original spare parts. They always meet the technical requirements laid out by us.

8.4 Wearing parts

WARNING

Failure to replace wear parts

Failure to replace wear parts can result in damage to the door construction and life-threatening injuries.

- ▶ Replace wear parts at the specified time.

Component	Exchange after
Curtain HR70 S	10,000 cycles
Curtain HR70 S aero	5,000 cycles
Barrel	10,000 cycles
Guide rail funnel	10,000 cycles
Operator	150 operating hours

8.5 Operator power

The voltage of the power supply must be 95% of the operator's supply voltage. Any voltage lower than this can lead to malfunctions in operating the door.

8.6 Wired closing edge safety device (SKS)

- ▶ When all components belonging to the SKS have been properly installed and connected, the green LED in the terminal box on the bottom profile lights up continuously.
- ▶ Check the function of the SKS by mechanically compressing the bottom rubber. The relay on the circuit board switches audibly and the right LED on the keypad lights up red.

- ▶ If the red LED display on the keypad flashes 9 times, there is an error on the SKS. To do this, please follow the instructions in section LED display on keypad.
- ▶ Check that the 3 wires of the SKS spiral cable are firmly seated on the terminals on the circuit board inside the SKS housing cover. If the terminals have loosened, tighten them again.

If the fault persists, instruct a specialist to put the SKS back into operation properly or to replace the bottom profile.

8.7 Accessories

- Only use original parts intended for use with this particular roller garage door. This ensures the high performance level of quality, safety, reliability, as well as a long service life.
- Loading of the operator by all electrical accessories: max. 100 mA.

8.8 Inspection and maintenance plan

NOTICES:

Please observe the following:

- The applicable regulations governing workplace safety when carrying out inspections and maintenance
- The notes in section 2 *Basic Safety Instructions on page 4*
- All inspection and maintenance information relating to the accessories

WARNING
<p>Actuation by other persons</p> <p>Actuating the door system while inspecting or performing maintenance work can lead to injuries and damage.</p> <ul style="list-style-type: none"> ▶ Make sure that whenever checks, maintenance work and cleaning are being carried out, the door system cannot be actuated by other persons. ▶ Follow all the inspection and maintenance information relating to the accessories.

Only inspect and maintain this door if you are a specialist, i.e. a competent person as defined in EN 12635. In other words, you have the suitable training, specialist knowledge and practical experience to allow you to carry out inspection and maintenance correctly and safely.

Component	Test criterion	OK
Guide rails	1. No deformation 2. Undamaged 3. Firmly fastened to the building structure 4. Tightening torque of the fixing material meets the requirements	
Slider profiles	1. No deformation 2. Undamaged	
Funnel	1. Undamaged 2. Firmly seated on the boom	
Data label	1. Available 2. Undamaged	

Component	Test criterion	OK
Door curtain	1. No increased abrasive wear or pressure marks 2. Undamaged 3. No unusual soiling (sand, chemicals etc.) 4. Curtain runs smoothly into the side guides	
End pieces	1. Complete 2. Undamaged 3. Firmly seated on the profiles 4. Fixing material undamaged	
Screw-on fixing brackets	1. Complete 2. Not bent up 3. No slotted holes present 4. Firmly seated on the barrel 5. Fixing material complete	
bottom profile	1. Undamaged	
Threshold seal¹⁾	1. Undamaged	
Support brackets	1. No deformation 2. Fixing material complete 3. Tightening torque of the fixing material meets the requirements	
Operator	1. No unusual sounds when running 2. No oil leaks 3. Fixing material complete 4. Tightening torque of the fixing material meets the requirements	
Catch safety device	1. Undamaged 2. Fixing material complete 3. Tightening torque of the fixing material meets the requirements 4. Electrical connection present and functional	
Barrel	1. Horizontally balanced and aligned 2. Undamaged 3. Smooth running 4. No subsequent changes	
Plug-in shaft	1. Firmly seated in the barrel 2. Square sufficiently embedded in catch safety device, safety marking not visible 3. Locking ring correctly positioned, tightening torque meets the requirements	
Wiring	1. Conforms to standard 2. Leads undamaged 3. Cable glands OK	
Locking rod¹⁾	1. Undamaged 2. In perfect working order	

1) Optional components

9 Cleaning and care

To preserve the surface characteristics, regular cleaning must be carried out at least every 3 months (door curtain, seals).

Contact with aggressive media (acids, alkali, salts, etc.) must always be avoided. If, however, the door surface or the attached parts are contaminated, they must immediately be rinsed completely of any residue using clear water.

ATTENTION

High-pressure cleaner

Cleaning the door system with a high-pressure cleaner can lead to door system malfunctions and damage.

- ▶ Do not use any high-pressure cleaners for cleaning the door system.

9.1 Door curtain

- Use warm water together with a neutral, non-abrasive cleaning agent (household detergent, pH value 7).
- To clean the surface, use only a soft cloth or chamois.
- Rinse off any dirt and dust particles with clear water.

10 Extension and conversion

WARNING

Use of non-authorised components

Non-authorised components could overload the door construction. This could lead to serious injuries and damage.

- ▶ Any conversion of the door system requires the express permission of the manufacturer.
- ▶ Only use components that have been approved by the manufacturer.

NOTE:

Carrying out any structural alterations to the product without the manufacturer's permission renders the warranty and product liability null and void.

11 Dismantling

NOTE:

When dismantling the system, observe the applicable regulations governing workplace safety.

1. Open the door completely.
2. Carefully roll up the door by hand.
3. Tape round the door barrel several times with strong adhesive tape (e.g. packing tape) to prevent it from unrolling.
4. Place an approved lifting device with a suitable pallet underneath the door barrel so that the door barrel lies on the pallet.

5. Loosen the fastening on the support brackets and side guides.
If the catch safety device is tripped, the connection between the support bracket and the side guide must only be released after any tension in the barrel has been released using the crank handle!
6. Lower the door system slowly using the lifting device.
7. Dismantle the door into component parts and dispose of them properly.

12 Excerpt from the Declaration of Incorporation

(as defined in EC Machinery Directive 2006/42/EC for incorporation of partly completed machinery according to annex II, part B).

The product described has been developed, constructed and produced in accordance with:

- EC Machinery Directive 2006/42/EC
- EC Construction Products Directive 89/106/EEC
- EU Low-Voltage Directive 2014/35/EU
- EU Electromagnetic Compatibility Directive 2014/30/EU

Applied and consulted standards:

- EN ISO 13849-1
Safety of machinery – Safety-related parts of control systems – Part 1: General principles for design
- EN 60335-2-95/103, when applicable
Safety of electrical appliances / Operators for doors
- EN 61000-6-3
Electromagnetic compatibility – Interference emission
- EN 61000-6-2
Electromagnetic compatibility – Interference immunity

Partly completed machinery as defined in the EC Directive 2006/42/EC is only intended to be incorporated into or assembled with other machinery or other partly completed machinery or equipment, thereby forming machinery to which this directive applies.

This is why this product must only be put into operation after it has been determined that the entire machine/system in which it has been installed corresponds with the guidelines of the EC directive mentioned above.

13 LED display on keypad

LED 1 green	LED 2 red	Status / malfunction / cause	Remedy
Illuminated		System ready for operation	
Flashes consistently		Hold-open phase running	
Illuminated	Flashes 2 ×	Safety equipment	Check photocell, replace if necessary.
Illuminated	Flashes 4 ×	Emergency stop activated (roll-off safeguard / emergency button)	Next travel command / cut-out mains
Illuminated	Flashes 6 ×	Travel time limit – motor travel time exceeded	Next travel command / cut-out mains
Illuminated	Flashes 9 ×	Safety equipment / safety edge actuated / defective	Check the safety edge, replace if necessary To do this, please follow the instructions in the section <i>Inspection and maintenance – checking wired safety edges</i>
Illuminated	Flashes consistently	Maintenance display / more than 2000 door cycles	Maintain door system / cut-out mains

14 Technical data

	ED45 / 50MA	ED59 / 140M
Mains voltage	230 V / 50 Hz	
Power input	0.2 kW	0.38 kW
Protection category	IP 44, VDE 0700	
Temperature range	–20 °C to +50 °C	
Nominal torque	50 Nm	140 Nm
Door cycles	× 2 h ⁻¹	

Dissemination as well as duplication of this document and the use and communication of its content are prohibited unless explicitly permitted. Noncompliance will result in damage compensation obligations. All rights reserved in the event of patent, utility model or design model registration. Subject to changes.

HÖRMANN KG Verkaufsgesellschaft
Upheider Weg 94 – 98
33803 Steinhagen
Germany
www.hoermann.com