

Technical manual

As of 01.03.2025

Industrial sectional doors

Series 60

Depth 42 mm

HÖRMANN

Table of contents

Contents		Page
Product descriptions		4–5
Technical Data Overview		6–7
Overview of Track Applications		8–9
SPU F42	Double-skinned steel sectional door, Stucco-textured / Micrograin, door sections 625 and 750 mm high	10
SPU F42	With wicket door with trip-free threshold, Stucco-textured / Micrograin, door sections 625 and 750 mm high	11
SPU F42	With wicket door and threshold rail, Stucco-textured / Micrograin, door sections 625 and 750 mm high	12
SPU F42	Double-skinned steel sectional door, Stucco-textured / Micrograin, door sections 375 and 500 mm high	13
SPU F42	With wicket door with trip-free threshold, Stucco-textured / Micrograin, door sections 375 and 500 mm high	14
SPU F42	With wicket door and threshold rail, Stucco-textured / Micrograin, door sections 375 and 500 mm high	15
SPU F42	Glazing heights (centre of window from FFL) for door section heights of 500, 625 and 750 mm	16
SPU F42	Calculating the glazing heights (centre of window from FFL)	17
APU F42	Glazed aluminium sectional door with steel bottom section	18
APU F42	Bottom section height 750 with wicket door and trip-free threshold	19
APU F42	Bottom section height 750 with wicket door and threshold rail	20
APU F42	Bottom section height 1500 with wicket door and trip-free threshold	21
APU F42	Bottom section height 1500 with wicket door and threshold rail	22
APU F42 Thermo	Glazed aluminium sectional door with thermal break, with steel bottom section	23
APU F42 Thermo	Bottom section height 750 with wicket door and trip-free threshold	24
APU F42 Thermo	Bottom section height 750 with wicket door and threshold rail	25
APU F42 Thermo	Bottom section height 1500 with wicket door and trip-free threshold	26
APU F42 Thermo	Bottom section height 1500 with wicket door and threshold rail	27
ALR F42	Glazed aluminium sectional door	28
ALR F42	with wicket door with trip-free threshold	29
ALR F42	with wicket door and threshold rail	30
ALR F42 Thermo	Glazed aluminium sectional door with thermal break	31
ALR F42 Thermo	with wicket door with trip-free threshold	32
ALR F42 Thermo	with wicket door and threshold rail	33
ALR F42 Glazing	Aluminium sectional door with extensive glazing, real glass	34
ALR F42 Vitraplan	Aluminium sectional door with exclusive glazing	35
ALR F42 Vitraplan AT	Aluminium sectional door with exclusive facade panels	36
Glazing and wicket door arrangements		37–39
Infills, fields and glazing series 40		40
Wind load class	Resistance to wind load	41
Side doors		
NT 60 / NT 80 Thermo	Possible handing options	42
Side doors NT 60		43–46
Side doors NT 60 RC 2		47
Side doors NT 80 Thermo		48–51
Side doors NT 80 Thermo RC 2		52
Fixed elements		53
Clear passage series 60		54–55
Track application N	Normal track application	56
Track application NA	Normal track application with high-mounted torsion spring shaft	57
Track application ND	Normal track application with inclination	58–59
Track application NS	Normal track application with double radius	60
Track application NK	Normal track application with double radius and inclination	61
Track application NH	Normal track application with minimum high-lift	62
Track application GD	Normal track application with inclination and minimum high-lift	63
Track application GS	Normal track application with double radius and minimum high-lift	64

Table of contents

Contents		Page
Track application GK	Normal track application with double radius and inclination and minimum high-lift	65
Track application L	Low headroom track application	66
Track application LD	Low headroom track application with inclination	67
Track application H	High-lift track application	68
Track application HA	High-lift track application with high-mounted torsion spring shaft	69
Track application HD	High-lift track application with inclination	70
Track application HS	High-lift track application with double radius	71
Track application HK	High-lift track application with double radius and inclination	72
Track application HU	High-lift track application with low-mounted torsion spring shaft	73
Track application RD	High-lift track application with low-mounted torsion spring shaft and inclination	74
Track application RS	High-lift track application with double radius and low-mounted torsion spring shaft	75
Track application RK	High-lift track application with double radius and inclination	76
Track application V	Vertical track application	77
Track application VA	Vertical track application with high-mounted torsion spring shaft	78
Track application VS	Vertical track application with inclination	79
Track application VU	Vertical track application with low-mounted torsion spring shaft	80
Track application WS	Vertical track application with inclination and low-mounted torsion spring shaft	81
Sideroom		82–83
Lintel fittings		84
Bottom edge		85
Chain hoist		86
Hand pulley with rope or link steel chain		87
Ceiling anchor		88–89
Diagonal strut		90
Shaft operator WA 300		91–94
Shaft operator WA 500 / 500 FU		95
	As a frame-mounted operator with chain box	96
	For central mounting	97–99
Chain drive operator ITO 500 FU		100
Operator SupraMatic HT		101–102
Shaft operators WA 300 / WA 500, door leaf speeds		103
Door leaf speeds WA 500 FU		104–105
Sectional door Parcel		106–107
Track application HP	High-lift track application for sectional door Parcel with high- and low-mounted torsion spring shaft	108
Track application VP	Vertical track application for sectional door Parcel with high- and low-mounted torsion spring shaft	109
Movable centre support	For industrial sectional doors with an opening width of up to 24 m	110–113
Infill overview and determination of the roof slope		114
Overview of profile cylinders		115

Note:

All information in this document can only represent the status upon document creation.
Therefore deviations from the product configurator may occur.
All dimensions in mm.
Subject to design changes.

Detailed door leaf constructions and track applications as well as fitting examples are provided in this manual.
No part may be reproduced without our prior permission.
All rights reserved.

Product descriptions

Door type	Door leaf / wicket door
Sectional door SPU F42: Double-skinned steel sectional door, Stucco-textured / Micrograin, door sections 625 and 750 mm high	
Door leaf	Door sections made of polyurethane-foamed, hot-galvanized sections. Door sections Stucco-textured on inside and outside with uniform horizontal ribbing, or Micrograin with fine horizontal embossing outside and Stucco-textured inside, 625 and 750 mm high, depth 42 mm. All door sections with finger trap protection. Surface protection with high-quality exterior coil coating and interior primer coating. Ventilation grilles optional.
Wicket door	Only to be installed in the centre fields of the door. Cannot be fitted in the outer fields – note the arrangement! Only opening outwards, LH or RH hinged. Ventilation grilles are not possible in wicket doors. In doors with wicket door without threshold rail, the clear frame dimension (ordering size, LZ) must not exceed the clear opening width + 10 mm. Attention (for threshold): For grid heights 2000, 2125 and 2250 mm, the clear opening height must not be lower than the door height.
Glazing	Glazing frames made of anodised aluminium extrusion profiles in the standard version or version with thermal break or alternatively sections with compound windows are possible within the indicated fitting area. Fewer compound glazings or different arrangements are possible subject to the minimum distances. Glazing frames are possible from FFL and compound glazing from 625/750 mm above FFL.
Sectional door SPU F42: Double-skinned steel sectional door, Stucco-textured / Micrograin, door sections 375 and 500 mm high	
Door leaf	Door sections made of polyurethane-foamed, hot-galvanized sections. Door sections Stucco-textured on inside and outside with uniform horizontal ribbing, or Micrograin with fine horizontal embossing outside and Stucco-textured inside, 375 and 500 mm high, depth 42 mm. All door sections with finger trap protection. Surface protection with high-quality exterior coil coating and interior primer coating. Ventilation grilles optional.
Wicket door	Only to be installed in the centre fields of the door. Cannot be fitted in the outer fields – note the arrangement! Only opening outwards, LH or RH hinged. Ventilation grilles are not possible in wicket doors. In doors with wicket door without threshold rail, the clear frame dimension (ordering size, LZ) must not exceed the clear opening width + 10 mm. Attention (for threshold): For grid heights 2000 and 2125 mm, the clear opening height must not be lower than the door height.
Glazing	Glazing frames made of anodised aluminium extrusion profiles in the standard version or version with thermal break or alternatively sections with compound windows are possible within the indicated fitting area. Fewer compound glazings or different arrangements are possible subject to the minimum distances. Glazing frames are possible from FFL and compound glazing from 500 mm above FFL.
Sectional door APU F42 / APU F42 Thermo: Glazed aluminium sectional door with steel bottom section / Glazed aluminium sectional door with thermal break, with steel bottom section	
Door leaf	Bottom section of hot-galvanized sections, infilled with polyurethane foam, 750 (standard version), or 1500 mm high, Stucco-textured inside and outside with uniform horizontal ribbing, or Micrograin with fine horizontal embossing outside and Stucco-textured inside. Surface protection with high-quality exterior coil coating and interior primer coating. Other door sections with glazing made of standard anodised aluminium extrusion profiles (APU F42) or with thermal break (APU F42 Thermo). Depth 42 mm. All door sections with finger trap protection. Infill: clear synthetic double panes, 26 mm (S2). Ventilation grilles in the bottom section optional.
Wicket door	Depending on the door type, made of standard anodised aluminium extrusion profiles or with thermal breaks, installed in the centre fields of the door. Cannot be fitted in the outer fields – note the arrangement! Only opening outwards, LH or RH hinged. Ventilation grilles are not possible in wicket doors. In doors with wicket door without threshold rail, the clear frame dimension (ordering size, LZ) must not exceed the clear opening width + 10 mm. Attention (for threshold rail): If the wicket door has the same number of sections as the sectional door, the clear opening height must not be lower than the door height (RM).
Sectional door ALR F42 / ALR F42 Thermo: Glazed aluminium sectional door / Glazed aluminium sectional door with thermal break	
Door leaf	Door sections made of standard anodised aluminium extrusion profiles (ALR F42) or with thermal break (ALR F42 Thermo). Depth 42 mm. All door sections with finger trap protection. Bottom door section made of PU infill with 26 mm Stucco-textured aluminium sheet cover on both sides (FU), other door sections with 26 mm clear synthetic double panes (S2). Ventilation grilles in the bottom section optional.
Wicket door	Depending on the door type, made of standard anodised aluminium extrusion profiles or with thermal breaks, installed in the centre fields of the door. Cannot be fitted in the outer fields – note the arrangement! Only opening outwards, LH or RH hinged. Ventilation grilles are not possible in wicket doors. In doors with wicket door without threshold rail, the clear frame dimension (ordering size, LZ) must not exceed the clear opening width + 10 mm. Attention (for threshold rail): If the wicket door has the same number of sections as the sectional door, the clear opening height must not be lower than the door height (RM).

Product descriptions

Door type		Door leaf / wicket door	
Sectional door ALR F42 Glazing: Aluminium sectional door with extensive glazing, real glass			
Door leaf	Door sections of standard anodised aluminium extrusion profiles. Depth 42 mm. All door sections with finger trap protection. All door section infills in 6 mm laminated safety glass (VG). Uniform infill heights.		
Sectional door ALR F42 Vitraplan: Aluminium sectional door with exclusive glazing			
Door leaf	Door sections of standard aluminium extrusion profiles. Depth 42 mm. Exterior and interior high-quality wet coating. All door sections with finger trap protection and synthetic double panes, 26 mm, clear (S2), and 4 mm transparent synthetic glazings fitted in front, in grey. Ventilation grilles are not possible in the bottom section.		
Sectional door ALR F42 Vitraplan AT: Aluminium sectional door with facade covering			
Door leaf	Door sections of standard aluminium extrusion profiles. Depth 42 mm. Exterior and interior high-quality wet coating. All door sections with finger trap protection and PU infill with aluminium sheet cover, Stucco-textured on both sides (FU), 26 mm and facade panels fitted in front. Ventilation grilles are not possible in the bottom section.		
Sectional door Parcel			
Door leaf	The divisible industrial door for special package loading requirements. The optimal solution for the joint use of the same loading bay by both lorries and vans.		
Door versions	SPU F42 Parcel, APU F42 Parcel Releasing an espagnolette lock can decouple one or more door sections.		
Frame / track application			
Enclosed, moulded angle frame with press-fitted external seal, made of hot-galvanized steel with screwed track and double radius 510 mm.			
Door lock			
Manually operated	Inside locking using a shootbolt, self-locking rotary latch (with track applications that have a low-mounted torsion spring shaft on request) or self-locking floor locking.		
Power-driven	Inside locking using a shootbolt		
Counterbalance			
Torsion springs, with carrying cables on the side (with a low headroom track application, a combination of carrying chain and carrying cable). The torsion springs are designed for track applications N, ND, NS, NK, NA, NH, GD, GK, GS, L and LD for at least 25000 closing cycles and for all other track applications for at least 50000 closing cycles. For version with direct drive operator via the operator, tubular shaft and carrying cables on the side.			
Safety-related equipment according to DIN EN 12604			
<ul style="list-style-type: none"> Manually operated doors using one torsion spring with approved catch safety device and integrated anti-lift kit on both sides ¹⁾ Manually operated doors using more than one torsion spring with approved spring safety device and with approved catch safety device and integrated anti-lift kit on both sides ¹⁾ Power-driven doors with break-in-resistant anti-lift kit Inner and outer finger trap protection <p>* European patent</p>			
Seals			
Bottom seal made of 5-chamber EPDM profile with flexible adjustment lip, side seal, lintel seal and intermediate seal between the door sections.			
Note regarding surface coating			
For the listed colours, the sectional doors SPU F42, APU F42 Thermo and ALR F42 Thermo with door widths from 4510 to 5000 mm in combination with track applications NH, GD, GK, GS, H, HD, HS, HK, HA, HU, RD, RS, RK, V, VA, VS, VU and WS are fitted with door leaf reinforcement to reduce any possible section deflection caused by sun exposure and require technical clarification.			
RAL 3007 Black red	RAL 6004 Blue green	RAL 6022 Olive drab	RAL 8019 Grey brown
RAL 5003 Sapphire blue	RAL 6005 Moss green	RAL 7016 Anthracite grey	RAL 8022 Black brown
RAL 5004 Black blue	RAL 6007 Bottle green	RAL 7021 Black grey	RAL 8028 Terra brown
RAL 5011 Steel blue	RAL 6008 Brown green	RAL 7043 Traffic grey	RAL 9004 Signal black
RAL 5013 Cobalt blue	RAL 6009 Fir green	RAL 8014 Sepia brown	RAL 9005 Jet black
RAL 5020 Ocean blue	RAL 6012 Black green	RAL 8016 Mahogany brown	RAL 9011 Graphite black
RAL 5022 Night blue	RAL 6015 Black olive	RAL 8017 Chocolate brown	RAL 9017 Traffic black
Colour CH 703			

Technical Data Overview

Construction and quality features	
Resistance to wind load EN 12424	Door without wicket door, LZ ≤ 4000, class
	Door without wicket door, LZ > 4000, class
	Door with wicket door, LZ ≤ 4000, class
	Door with wicket door, LZ > 4000, class
Water tightness EN 12425	Door without / with wicket door, class
Air permeability EN 12426	Door without wicket door, class
	Door with wicket door, class
Acoustic value EN 717-1	Door without wicket door $R_w = \dots$ dB
	Door with wicket door $R_w = \dots$ dB
Thermal resistance EN 13241-1, appendix B EN 12428	Door without wicket door, $U = W/m^2 \cdot K^{2)}$
	- Optional PU sandwich infill, $U = W/m^2 \cdot K^{2)}$
	- Optional triple panes, $U = W/m^2 \cdot K^{2)}$
	- Optional climatic double panes (single-pane safety glass) $U = W/m^2 \cdot K^{2)}$
	- Optional double panes (single-pane safety glass) $U = W/m^2 \cdot K^{2)}$
	Door with wicket door, $U = W/m^2 \cdot K^{2)}$
	- Section, $U = W/m^2 \cdot K$
Design	Self-supporting
	Depth, mm
Door sizes	Max. width mm, LZ
	Max. height mm, RM ³⁾
Space requirement	From page 54
Material, door leaf	Steel, double-skinned, 42 mm
	Aluminium, standard profile
	Aluminium, profile with thermal break
Surface finish, door leaf	Galvanized steel, high-quality exterior coating in RAL 9002
	Galvanized steel, high-quality exterior coating in RAL 9006
	Galvanized steel, high-quality exterior coating in RAL to choose
	Anodised aluminium E6/C0 (previously E6/EV1)
	Aluminium high-quality exterior coating in RAL to choose
	Aluminium high-quality coating in RAL 9005
Door leaf reinforcement	From LZ, mm
	Notice regarding surface coating, see page 5, from LZ, mm
Wicket door	
Side door	matching the door
Glazings	Type A section window
	Type D section window
	Type E section window
	Section window type F
	Glazing frame
Seals	All-round on 4 sides
	Intermediate seal between the door sections
ThermoFrame	PVC hard and soft seal
Locking system	Inside locking
	Outside and inside locking
Security equipment	Anti-lift kit
	RC2 security features
Safety features in acc. with EN 13241	Finger trap protection
	Side trap guards
	Safety catch
Fastening options	Concrete
	Steel
	Brickwork
	Others on request

- Standard
- Optional
- * With glazing VG, E2 and G2
- ** Top door section

- 1) With optional double pane (single-pane safety glass)
- 2) For a door surface of 5000 × 5000 mm
- 3) Door height above 7000 mm on request (not with door type ALR F42 Glazing)
- 4) Optionally with ThermoFrame
- 5) Class 4 = 1.0 kN/m² or 144 km/h
- 6) Class 3 = 0.7 kN/m² or 120 km/h
- 7) Class 2 = 0.45 kN/m² or 96 km/h

Technical Data Overview

SPU F42	APU F42	APU F42 Thermo	ALR F42	ALR F42 Thermo	ALR F42 Vitraplan	ALR F42 Vitraplan AT	ALR F42 Glazing
4 ^{5) 10)}	4 ⁵⁾	4 ⁵⁾	4 ⁵⁾	4 ⁵⁾	4 ⁵⁾	4 ⁵⁾	4 ⁵⁾
3 ^{6) 10)}	3 ⁶⁾	3 ⁶⁾	3 ⁶⁾	3 ⁷⁾	3 ⁶⁾	3 ⁶⁾	3 ⁶⁾
3 ^{6) 10)}	3 ⁶⁾	3 ⁶⁾	3 ⁶⁾	3 ⁶⁾	–	–	–
2 ^{7) 10)}	2 ⁷⁾	2 ⁷⁾	2 ⁷⁾	2 ⁷⁾	–	–	–
3 (70 Pa)	3 (70 Pa)	3 (70 Pa)	3 (70 Pa)	3 (70 Pa)	3 (70 Pa)	3 (70 Pa)	3 (70 Pa)
2 ⁸⁾	2 ⁸⁾	2 ⁸⁾	2 ⁸⁾	2 ⁸⁾	2 ⁸⁾	2 ⁸⁾	2 ⁸⁾
1 ⁹⁾	1 ⁹⁾	1 ⁹⁾	1 ⁹⁾	1 ⁹⁾	–	–	–
25 ¹¹⁾	23	23	23 (30 ¹⁾)	23 (30 ¹⁾)	23	23	30 ¹⁾
24 ¹¹⁾	22	22	22 (29 ¹⁾)	22 (29 ¹⁾)	–	–	–
1,0 (0,94 ⁴⁾)	3,4 (3,3 ⁴⁾)	2,9 (2,8 ⁴⁾)	3,6 (3,6 ⁴⁾)	3,0 (3,0 ⁴⁾)	3,2 (3,2 ⁴⁾)	3,2 (3,2 ⁴⁾)	6,1 (6,1 ⁴⁾)
–	2,4 (2,3 ⁴⁾)	1,9 (1,8 ⁴⁾)	2,6 (2,6 ⁴⁾)	2,0 (2,0 ⁴⁾)	–	2,6 (2,6 ⁴⁾)	–
–	3,0 (2,9 ⁴⁾)	2,5 (2,4 ⁴⁾)	3,2 (3,1 ⁴⁾)	2,6 (2,5 ⁴⁾)	3,0 (2,9 ⁴⁾)	3,0 (2,9 ⁴⁾)	–
–	2,5 (2,4 ⁴⁾)	2,0 (1,9 ⁴⁾)	2,7 (2,6 ⁴⁾)	2,1 (2,0 ⁴⁾)	–	–	2,7 (2,6 ⁴⁾)
–	3,4 (3,3 ⁴⁾)	2,9 (2,8 ⁴⁾)	3,6 (3,6 ⁴⁾)	3,0 (3,0 ⁴⁾)	–	–	3,8 (3,8 ⁴⁾)
1,2 (1,2 ⁴⁾)	3,6 (3,6 ⁴⁾)	3,1 (3,1 ⁴⁾)	3,8 (3,8 ⁴⁾)	3,2 (3,2 ⁴⁾)	–	–	–
–	3,2 (3,1 ⁴⁾)	2,7 (2,6 ⁴⁾)	3,4 (3,4 ⁴⁾)	2,8 (2,8 ⁴⁾)	–	–	–
0,5	–	–	–	–	–	–	–
●	●	●	●	●	●	●	●
42	42	42	42	42	42	42	42
8000	8000	7000	8000	7000	6000	6000	5500
7500	7500	7500	7500	7500	7500	7500	4000
●	●	●	–	–	–	–	–
–	●	–	●	–	●	●	●
–	–	●	–	●	–	–	–
●	○	○	–	–	–	–	–
○	●	●	–	–	–	–	–
○	○	○	–	–	–	–	–
○	●	●	●	●	–	–	●
○	○	○	○	○	–	–	○
–	–	–	–	–	●	●	–
4010*/5010	4010**/5010	4010**/5010	4010**/5010	4010**/5010	●	●	3340
4510	–	4510	–	4510	●	●	3340
○	○	○	○	○	–	–	–
○	○	○	○	○	○	○	–
○	–	–	–	–	–	–	–
○	–	–	–	–	–	–	–
○	–	–	–	–	–	–	–
○	–	–	–	–	–	–	–
○	●	●	●	●	●	●	●
●	●	●	●	●	●	●	●
●	●	●	●	●	●	●	●
○	○	○	○	○	○	○	○
●	●	●	●	●	●	●	●
○	○	○	○	○	–	–	–
●	●	●	●	●	●	●	●
○	–	–	–	–	–	–	–
●	●	●	●	●	●	●	●
●	●	●	●	●	●	●	●
●	●	●	●	●	●	●	●
●	●	●	●	●	●	●	●
●	●	●	●	●	●	●	●
●	●	●	●	●	●	●	●
●	●	●	●	●	●	●	●

8) Class 2 = 12 m³/m²h

11) For doors without glazing frame

9) Class 1 = 24 m³/m²h

10) Lower class rating may apply for doors with compound windows

Overview of Track Applications

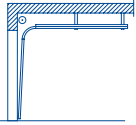
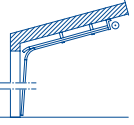
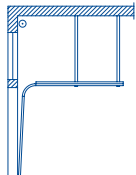
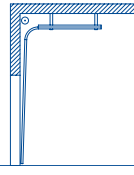
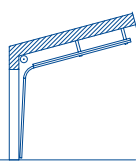
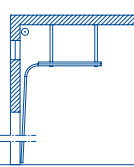
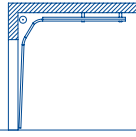
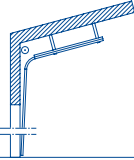
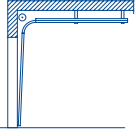
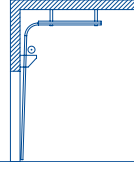
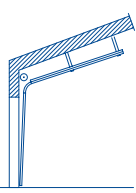
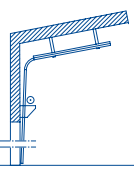
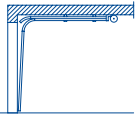
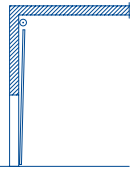
<p>N</p>  <p>Normal track application</p> <p>A WA 500 FU is required for track application N3 with operator!</p>	<p>LD</p>  <p>As with track application L with inclination (maximum 30°)</p> <p>Door height RM ≤ 5000 mm</p>
<p>NA</p>  <p>Like track application N, with high-mounted torsion spring shaft</p> <p>Door height RM ≤ 5000 mm</p>	<p>H</p>  <p>High-lift track application</p>
<p>ND</p>  <p>As with track application N with inclination (maximum 46°)</p> <p>A WA 500 FU is required for track application ND3 with operator at an inclination of up to 6°!</p>	<p>HA</p>  <p>Like track application H, with high-mounted torsion spring shaft</p> <p>Door height RM ≤ 3500 mm</p>
<p>NS</p>  <p>As with track application N with double radius</p> <p>Door height RM ≤ 5000 mm</p> <p>RC2 version only possible with angle C = 40° and 45°.</p>	<p>HD</p>  <p>As with track application H with inclination (maximum 30°)</p>
<p>NH</p>  <p>As with track application N, with minimum high-lift</p> <p>Double radius 361 mm</p> <p>Door leaf speed up to 500 mm/s possible.</p> <p>Door height > 5000 mm</p> <p>A WA 500 FU is required for track application NH3 with operator!</p>	<p>HU</p>  <p>Like track application H, with low-mounted torsion spring shaft</p>
<p>GD</p>  <p>As with track application NH, with inclination (maximum 28°)</p> <p>Double radius 361 mm</p> <p>Door height RM ≤ 5000 mm</p>	<p>RD</p>  <p>Like track application HU, with inclination</p> <p>Door height RM ≤ 5000 mm</p>
<p>L</p>  <p>Low headroom track application</p> <p>Door height RM ≤ 5000 mm</p>	<p>V</p>  <p>Vertical track application (Additional hand pulley required for manually operated doors!)</p>

Overview of Track Applications

<p>VA</p>  <p>Like track application V, with high-mounted torsion spring shaft (Additional hand pulley required for manually operated doors!)</p> <p>Door height RM ≤ 3500 mm</p>	<p>VU</p>  <p>Like track application V, with low-mounted torsion spring shaft (Additional hand pulley required for manually operated doors!)</p>
<p>Note: An in-factory technical inspection is required for the following track applications!</p>	
<p>NK</p>  <p>Like track application NS, but the degree values of both radii are adapted to the situation on site</p> <p>Door height RM ≤ 5000 mm</p> <p>RC2 version only possible with angle C = 40° and 45°.</p>	<p>GS</p>  <p>As with track application NH with double radius</p> <p>Door height RM ≤ 5000 mm</p>
<p>GK</p>  <p>As with track application NH with double radius and inclination Double radius 361 mm</p> <p>Door height RM ≤ 5000 mm</p>	<p>HS</p>  <p>As with track application H with double radius</p>
<p>HK</p>  <p>As with track application H, with double radius and inclination</p>	<p>VS</p>  <p>Like track application V, but in the top sections the tracks are diverted using radii where the ceiling is too low (Additional hand pulley required for manually operated doors!)</p>
<p>WS</p>  <p>Like track application VU, but in the top sections the tracks are diverted using radii where the ceiling is too low (Additional hand pulley required for manually operated doors!)</p> <p>Door height RM ≥ 2250 mm</p>	<p>RS</p>  <p>As with track application HU with double radius</p> <p>Door height RM ≤ 5000 mm</p>
<p>RK</p>  <p>As with track application HU, with double radius and inclination</p> <p>Door height RM ≤ 5000 mm</p>	
<p>Note: The sectional door Parcel is only available with these track applications. Technical factory inspection required!</p>	
<p>HP</p>  <p>High-lift track application With high- and low-mounted torsion spring shaft Double radius 361 mm Door width LZ ≤ 3000 mm Door height RM ≤ 4250 mm Only for sectional door Parcel</p>	<p>VP</p>  <p>Vertical track application With high- and low-mounted torsion spring shaft Door width LZ ≤ 3000 mm Door height RM ≤ 4250 mm Only for sectional door Parcel</p>

Sectional door SPU F42

Double-skinned steel sectional door

Stucco-textured / Micrograin

Door sections 625 and 750 mm high

External views

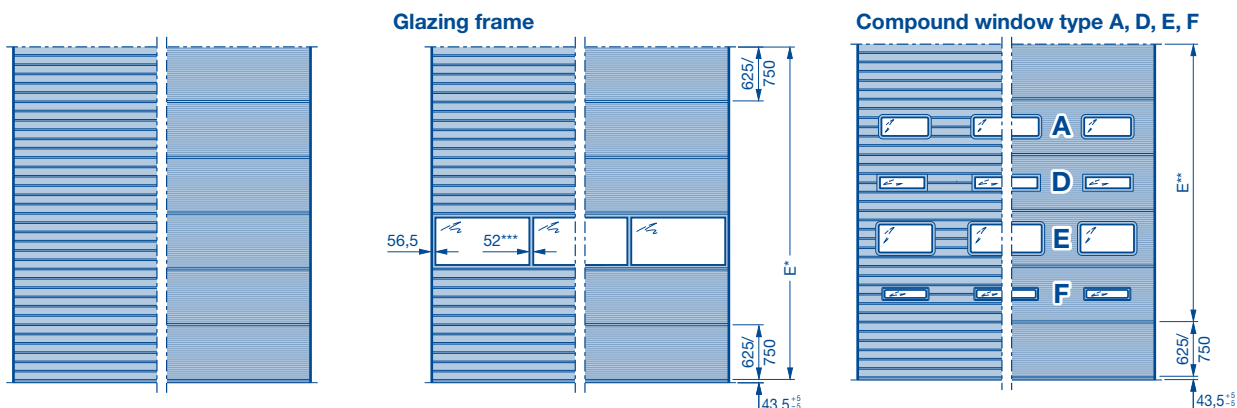

For dimensions of the compound windows, see page 16.

E* Fitting area for frames with glazing

E** Fitting area for compound windows

*** Optionally with wide rail extrusions (91 mm)

Size range

The validity tables with the size range shown are based on the standard door type version (see product description). In case of deviations, the valid size ranges in the product configurator must be taken into account. Any door width in 10 mm increments possible. Intermediate heights using aluminium glazing frames or shortened top door section are possible!

RM	RM					TH 625		TH 750	
	1	2	3	4	5	n ₁	n ₁	n ₁	
Range 3	7500							10	
	7375							9	
	7250							8	
	7125							7	
	7000							6	
	6875							5	
	6750							4	
	6625							3	
	6500							2	
	6375							1	
Range 2	6250							6	
	6125							5	
	6000							4	
	5875							3	
	5750							2	
	5625							1	
	5500							6	
	5375							5	
	5250							4	
	5125							3	
Range 1	5000							2	
	4875							1	
	4750							6	
	4625							5	
	4500							4	
	4375							3	
	4250							2	
	4125							1	
	4000							6	
	3875							5	
Range 1	3750							4	
	3625							3	
	3500							2	
	3375							1	
	3250							6	
	3125							5	
	3000							4	
	2875							3	
	2750							2	
	2625							1	
Range 1	2500							6	
	2375							5	
	2250							4	
	2125							3	
	2000							2	
	1875							1	
								6	
								5	
								4	
								3	
							2		
							1		
							6		
							5		
							4		
							3		
							2		
							1		
							6		
							5		
							4		
							3		
							2		
							1		
							6		
							5		
							4		
							3		
							2		
							1		
							6		
							5		
							4		
							3		
							2		
							1		
							6		
							5		
							4		
							3		
							2		
							1		
							6		
							5		
							4		
							3		
							2		
							1		
							6		
							5		
							4		
							3		
							2		
							1		
							6		
							5		
							4		
							3		
							2		
							1		
							6		
							5		
							4		
							3		
							2		
							1		
							6		
							5		
							4		
							3		
							2		
							1		
							6		
							5		
							4		
							3		
							2		
							1		
							6		
							5		
							4		
							3		
							2		
							1		
							6		
							5		
							4		
							3		
							2		
							1		
							6		
							5		
							4		
							3		
							2		
							1		
							6		
							5		
							4		
							3		
							2		
							1		
							6		
							5		
							4		
							3		
							2		
							1		
							6		
							5		
							4		
							3		
							2		
							1		
							6		
							5		
							4		
							3		
							2		
							1		
							6		
							5		
							4		
							3		
							2		
							1		
							6		
							5		
							4		
							3		
							2		
							1		
							6		
							5		
							4		
							3		
							2		
							1		
							6		
							5		
							4		
							3		
							2		
							1		
							6		
							5		
							4		
							3		
							2		
							1		
							6		
							5		
							4		
							3		
							2		
							1		
							6		
							5		
							4		
							3		
							2		
							1		
							6		
							5		
							4		
							3		
							2		
							1		
							6		
							5		
							4		
							3		
							2		
							1		
							6		
							5		
							4		
							3		
							2		
							1		
							6		
							5		
							4		
							3		
							2		
							1		
							6		
					</				

Sectional door SPU F42 with wicket door with trip-free threshold

Double-skinned steel sectional door

Stucco-textured / Micrograin, door sections 625 and 750 mm high,

External views

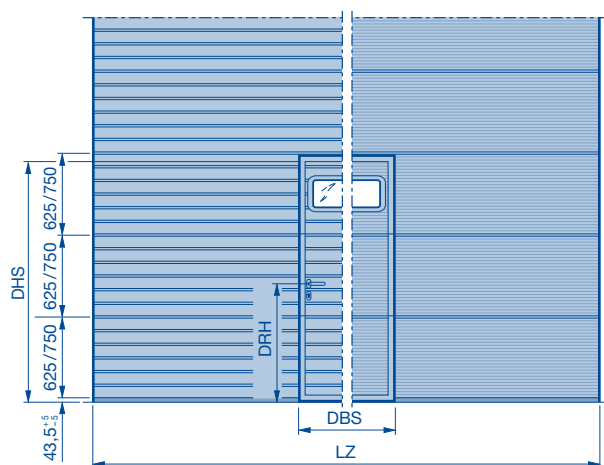

** Note on fitting compound windows:

For door widths from 1750 – 3000 mm, a compound window can **only** be fitted in the wicket door. No compound window can be fitted to the left or right of the wicket door. Compound window type E must not be used in the wicket door area.

Wicket door clear passage width (DBS) = 940 mm*

* For a door width of 1750 - 1840 mm, the clear passage width is 833 mm.
For door widths below 1750 mm, the clear passage width (DBS) depends on the door width and is much smaller than standard dimensions.

Lever heights (DRH)

Bottom door section 625 = 960.5
Bottom door section 750 = 1085.5

Size range

The validity tables with the size range shown are based on the standard door type version (see product description). In case of deviations, the valid size ranges in the product configurator must be taken into account. Any door width in 10 mm increments possible. Intermediate heights using glazing frames or shortened top door section above wicket door are possible!

RM	Range 3	SH ₁					SH ₂					TH 625	n ₁	TH 750	DHS														
		1	2	3	4	5	1	2	3	4	5																		
7500												7500	-	10	2205														
7375												7375	1	+	9	2205													
7250												7250	2	+	8	2205													
7125												7125	3	+	7	2205													
7000												7000	4	+	6	2205													
6875												6875	5	+	5	2205													
6750												6750	-	-	9	2205													
6625												6625	1	+	8	2205													
6500												6500	2	+	7	2205													
6375												6375	3	+	6	2205													
6250												6250	4	+	5	2205													
6125												6125	5	+	4	2205													
6000												6000	-	-	8	2205													
5875												5875	1	+	7	2205													
5750												5750	2	+	6	2205													
5625												5625	3	+	5	2205													
5500												5500	4	+	4	2205													
5375												5375	5	+	3	2205													
5250												5250	-	-	7	2205													
5125												5125	1	+	6	2205													
5000												5000	2	+	5	2205													
4875												4875	3	+	4	2205													
4750												4750	4	+	3	2205													
4625												4625	5	+	2	2080													
4500												4500	-	-	6	2205													
4375												4375	1	+	5	2205													
4250												4250	2	+	4	2205													
4125												4125	3	+	3	2205													
4000												4000	4	+	2	2080													
3875												3875	5	+	1	1955													
3750												3750	-	-	5	2205													
3625												3625	1	+	4	2205													
3500												3500	2	+	3	2205													
3375												3375	3	+	2	2080													
3250												3250	4	+	1	1955													
3125												3125	5	-	-	1830													
3000												3000	-	-	4	2205													
2875												2875	1	+	3	2205													
2750												2750	2	+	2	2080													
2625												2625	3	+	1	1955													
2500												2500	4	-	-	1830													
2375												2375	3	+	1***	1830													
2250												2250	-	-	3	2125													
2125												2125	1	+	2	2000													
2000												2000	2	+	1	1875													
1875												1875	-	-	-	-													
												3	4	5	Number of infills / fields per glazing frame														
												2	3	4	5	Number of compound glazings per door section**													
												(Number of infills / fields - 1) × 2				Number of ventilation grilles, ventilation cross-section 40 cm ² per grille													
												1750	2000	2250	2500	2750	3000	3250	3500	3750	4000	4250	4500	4750	5000	5250	5500	5750	6000
												SPB 52																	
												LZ																	

Notes:

- When using a shaft operator (installation example 5), the door locking is always opposite the operator side.
- For a view of the matching appearance with doors without wicket door see pages 37 – 39.
- Number of glazings, matching series 40, see page 40.

On request

Versions with glazing frame A3, M3, S3, U3, LB, P on request

n₁ No. of door sections

DHS Clear passage heights of wicket door to grid height

SH₁ Threshold height (rising from 5 to 10)

SH₂ Threshold height (approx. 13)

SPB Rail width

TH Door section height

RM Grid height

DBS Wicket door clear passage width

DRH Lever height

LZ Clear frame dimensions (from 1500)

*** Top door section 500 mm

Sectional door SPU F42 with wicket door and threshold rail

Double-skinned steel sectional door

Stucco-textured / Micrograin, door sections 625 and 750 mm high

External views

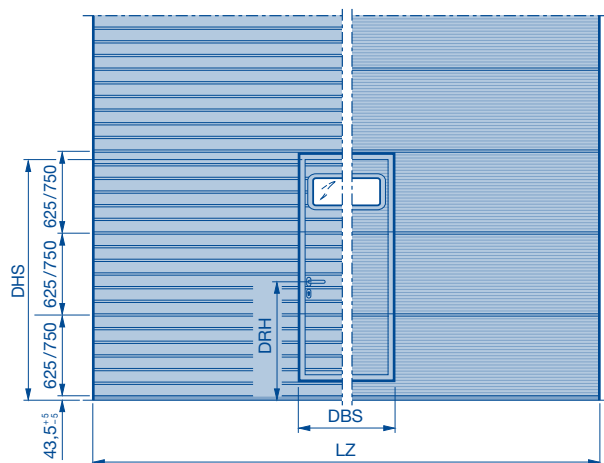

** Note on fitting compound windows:

For door widths from 1750 – 3000 mm, a compound window can **only** be fitted in the wicket door. No compound window can be fitted to the left or right of the wicket door. Compound window type E must not be used in the wicket door area.

Wicket door clear passage width (DBS) = 940 mm*

* For a door width of 1750 - 1840 mm, the clear passage width is 833 mm. For door widths below 1750 mm, the clear passage width (DBS) depends on the door width and is much smaller than standard dimensions.

Lever heights (DRH)

Bottom door section 625 = 960.5
Bottom door section 750 = 1085.5

Size range

The validity tables with the size range shown are based on the standard door type version (see product description). In case of deviations, the valid size ranges in the product configurator must be taken into account. Any door width in 10 mm increments possible. Intermediate heights using glazing frames or shortened top door section above wicket door are possible!

RM	SH ₁				SH ₂	TH 625	n ₁	TH 750	DHS													
	3	4	5	6																		
7500						-	10		2205													
7375						1	+	9	2205													
7250						2	+	8	2205													
7125						3	+	7	2205													
7000						4	+	6	2205													
6875						5	+	5	2205													
6750						-		9	2205													
6625						1	+	8	2205													
6500						2	+	7	2205													
6375						3	+	6	2205													
6250						4	+	5	2205													
6125						5	+	4	2205													
6000						-		8	2205													
5875						1	+	7	2205													
5750						2	+	6	2205													
5625						3	+	5	2205													
5500						4	+	4	2205													
5375						5	+	3	2205													
5250						-		7	2205													
5125						1	+	6	2205													
5000						2	+	5	2205													
4875						3	+	4	2205													
4750						4	+	3	2205													
4625						5	+	2	2080													
4500						-		6	2205													
4375						1	+	5	2205													
4250						2	+	4	2205													
4125						3	+	3	2205													
4000						4	+	2	2080													
3875						5	+	1	1955													
3750						-		5	2205													
3625						1	+	4	2205													
3500						2	+	3	2205													
3375						3	+	2	2080													
3250						4	+	1	1955													
3125						-		-	1830													
3000						1	+	4	2205													
2875						2	+	3	2205													
2750						3	+	2	2080													
2625						4	+	1	1955													
2500						-		-	1830													
2375						3	+	1***	1830													
2250						-		3	2205													
2125						1	+	2	2080													
2000						2	+	1	1955													
1875						-		-	-													
					3	Number of infills / fields per aluminium frame																
					2	3	4	5	Number of compound glazings per door section**													
					(Number of infills / fields - 1) × 2				Number of ventilation grilles, ventilation cross-section 40 cm ² per grille													
					1750	2000	2250	2500	2750	3000	3250	3500	3750	4000	4250	4500	4750	5000	5250	5500	5750	6000
					SPB 52																	
					LZ																	

Notes:

- When using a shaft operator (installation example 5), the door locking is always opposite the operator side.
- For a view of the matching appearance with doors without wicket door see pages 37 – 39.
- Number of glazings, matching series 40, see page 40.
- For versions with real glass infill in the wicket door, the threshold height SH₂ begins at LZ 4510 mm.

On request

Versions with glazing frame A3, M3, S3, U3, LB, P on request

Glazings on request

n₁ No. of door sections

DHS Clear passage heights of wicket door to grid height

SH₁ Threshold height (207)

SH₂ Threshold height (330), bottom door section with 250 mm aluminium bottom section

SPB Rail width

TH Door section height

RM Grid height

DBS Wicket door clear passage width

DRH Lever height

LZ Clear frame dimensions (from 1500)

*** Top door section 500 mm

Sectional door SPU F42

Double-skinned steel sectional door

Stucco-textured / Micrograin

Door sections 375 and 500 mm high

External views

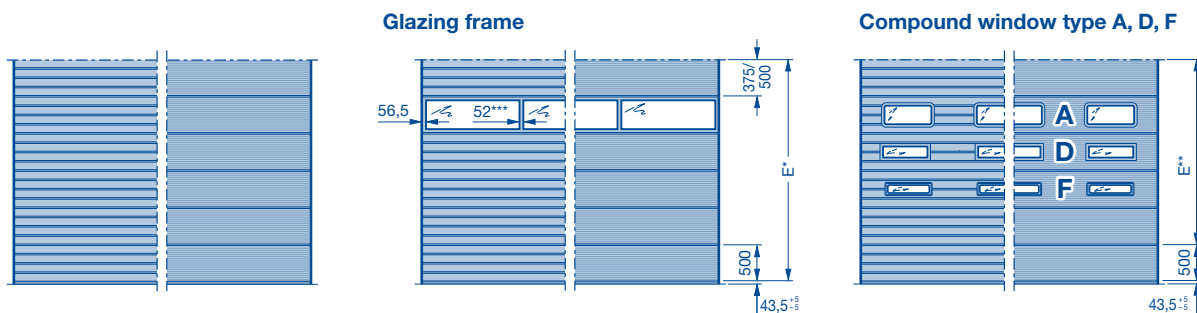

For dimensions of the compound windows, see page 16.

E* Fitting area for frame 500 with glazing

E** Fitting area for compound windows

*** Optionally with wide rail extrusions (91 mm)

Size range

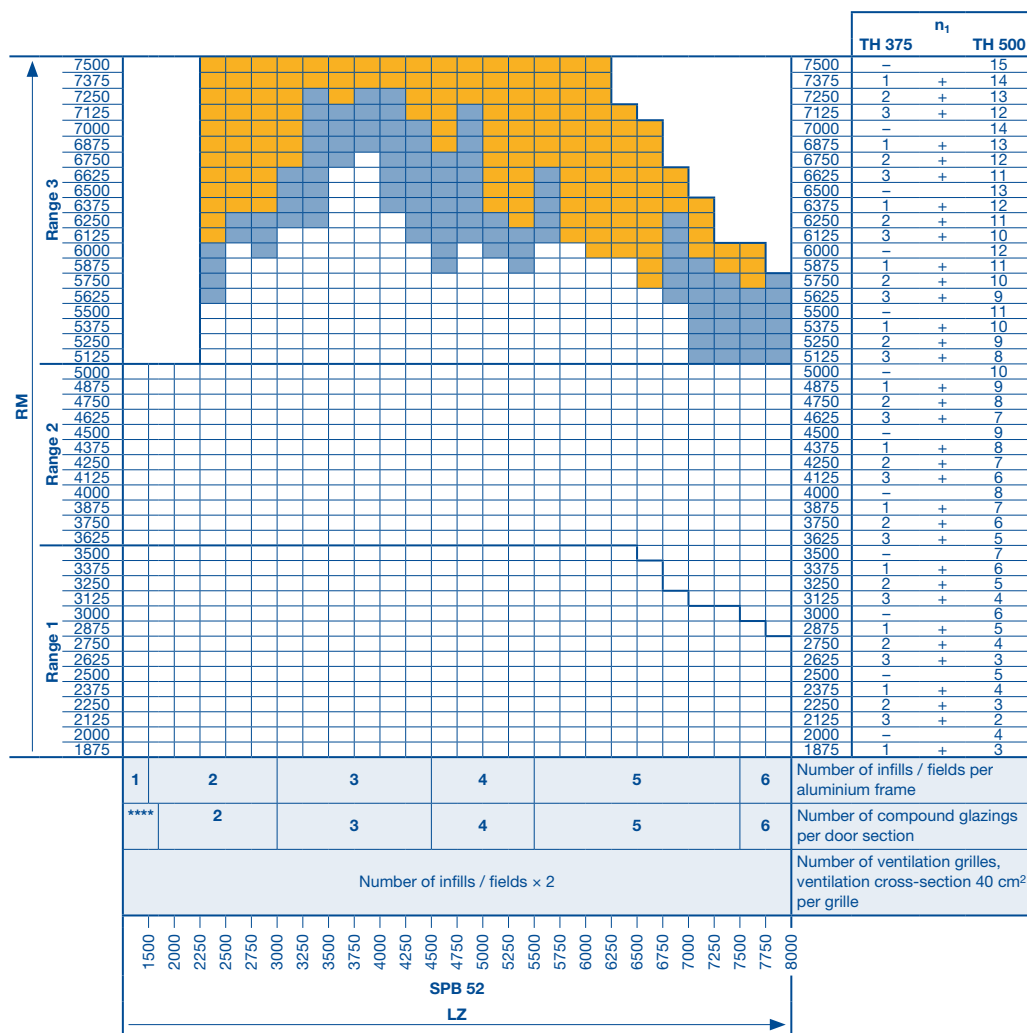

The validity tables with the size range shown are based on the standard door type version (see product description). In case of deviations, the valid size ranges in the product configurator must be taken into account. Any door width in 10 mm increments possible. Intermediate heights using aluminium glazing frames or shortened top door section are possible!

Notes:

- Glazing frame as thermo version only up to 7000 mm wide.
- For a view of the matching appearance with doors with wicket door see pages 37 – 39.
- Number of glazings, matching series 40, see page 40.

On request

Versions with glazing frame A3, M3, S3, U3, LB, P on request

Range change

n₁ No. of door sections

RM Grid height

LZ Clear frame dimensions (from 1200)

SPB Rail width

TH Door section height

**** See Table 1 on page 10

Sectional door SPU F42 with wicket door with trip-free threshold

Double-skinned steel sectional door

Stucco-textured / Micrograin, door sections 375 and 500 mm high

External view

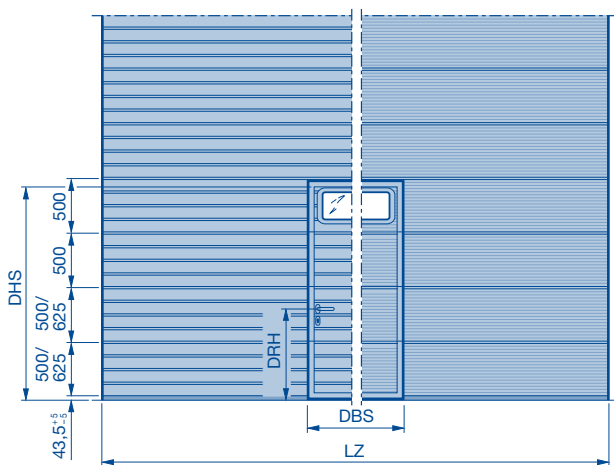

** Note on fitting compound glazings:

For door widths from 1750 – 3000 mm, a compound window can **only** be fitted in the wicket door. No compound window can be fitted to the left or right of the wicket door.

Wicket door clear passage width (DBS) = 940 mm*

* For a door width of 1750 - 1840 mm, the clear passage width is 833 mm. For door widths below 1750 mm, the clear passage width (DBS) depends on the door width and is much smaller than standard dimensions.

Lever heights (DRH)

Bottom door section 500 = 835.5

Bottom door section 625 = 960.5

Size range

The validity tables with the size range shown are based on the standard door type version (see product description). In case of deviations, the valid size ranges in the product configurator must be taken into account. Any door width in 10 mm increments possible. Intermediate heights using glazing frames or shortened top door section above wicket door are possible!

RM	SH ₁				SH ₂				n ₁		DHS										
	TH 375	TH 500	TH 375	TH 500	TH 375	TH 500	TH 375	TH 500	TH 375	TH 500											
7500											1955										
7375											1955										
7250											1955										
7125											1955										
7000											1955										
6875											1955										
6750											1955										
6625											1955										
6500											1955										
6375											1955										
6250											1955										
6125											1955										
6000											1955										
5875											1955										
5750											1955										
5625											1955										
5500											1955										
5375											1955										
5250											1955										
5125											1955										
5000											1955										
4875											1955										
4750											1955										
4625											1955										
4500											1955										
4375											1955										
4250											1955										
4125											1955										
4000											1955										
3875											1955										
3750											1955										
3625											1955										
3500											1955										
3375											1955										
3250											1955										
3125											1955										
3000											1955										
2875											1955										
2750											1955										
2625											2080										
2500											1955										
2375											1955										
2250											2125										
2125											2000										
2000											1875										
3											Number of infills / fields per glazing frame										
2											Number of compound glazings per door section**										
(Number of infills / fields - 1) x 2											Number of ventilation grilles, ventilation cross-section 40 cm ² per grille										
1750	2000	2250	2500	2750	3000	3250	3500	3750	4000	4250	4500	4750	5000	5250	5500	5750	6000	6250	6500	6750	7000
SPB 52																					
LZ																					

Notes:

- For a view of the matching appearance with doors without wicket door see pages 37 – 39.
- Number of glazings, matching series 40, see page 40.
- For versions with real glass infill in the wicket door, the threshold height **SH₂** begins at LZ 4510 mm.

	On request
	Versions with glazing frame A3, M3, S3, U3, LB, P on request
	Range change
	Glazings on request
n₁	No. of door sections
DHS	Clear passage heights of wicket door to grid height
RM	Grid height
LZ	Clearance dimensions (from 1500)
SH₁	Threshold height (rising from 5 to 10)
SH₂	Threshold height (approx. 13)
SPB	Rail width
TH	Door section height
DRH	Lever height
DBS	Wicket door clear passage width
***	TH = 625 mm

Sectional door SPU F42 with wicket door and threshold rail

Double-skinned steel sectional door

Stucco-textured / Micrograin, door sections 375 and 500 mm high

External view

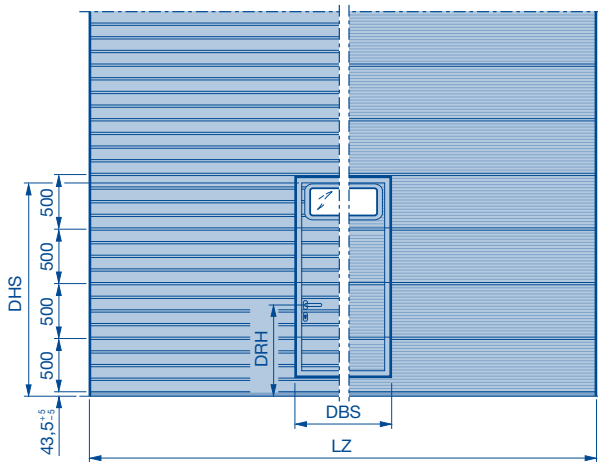

** Note on fitting compound glazings:

For door widths from 1750 – 3000 mm, a compound window can **only** be fitted in the wicket door. No compound window can be fitted to the left or right of the wicket door.

Wicket door clear passage width (DBS) = 940 mm*

* For a door width of 1750 - 1840 mm, the clear passage width is 833 mm. For door widths below 1750 mm, the clear passage width (DBS) depends on the door width and is much smaller than standard dimensions.

Lever heights (DRH)

Bottom door section 500 = 835.5
Bottom door section 625 = 960.5 (only for SH₂)

Size range

The validity tables with the size range shown are based on the standard door type version (see product description). In case of deviations, the valid size ranges in the product configurator must be taken into account. Any door width in 10 mm increments possible. Intermediate heights using glazing frames or shortened top door section above wicket door are possible!

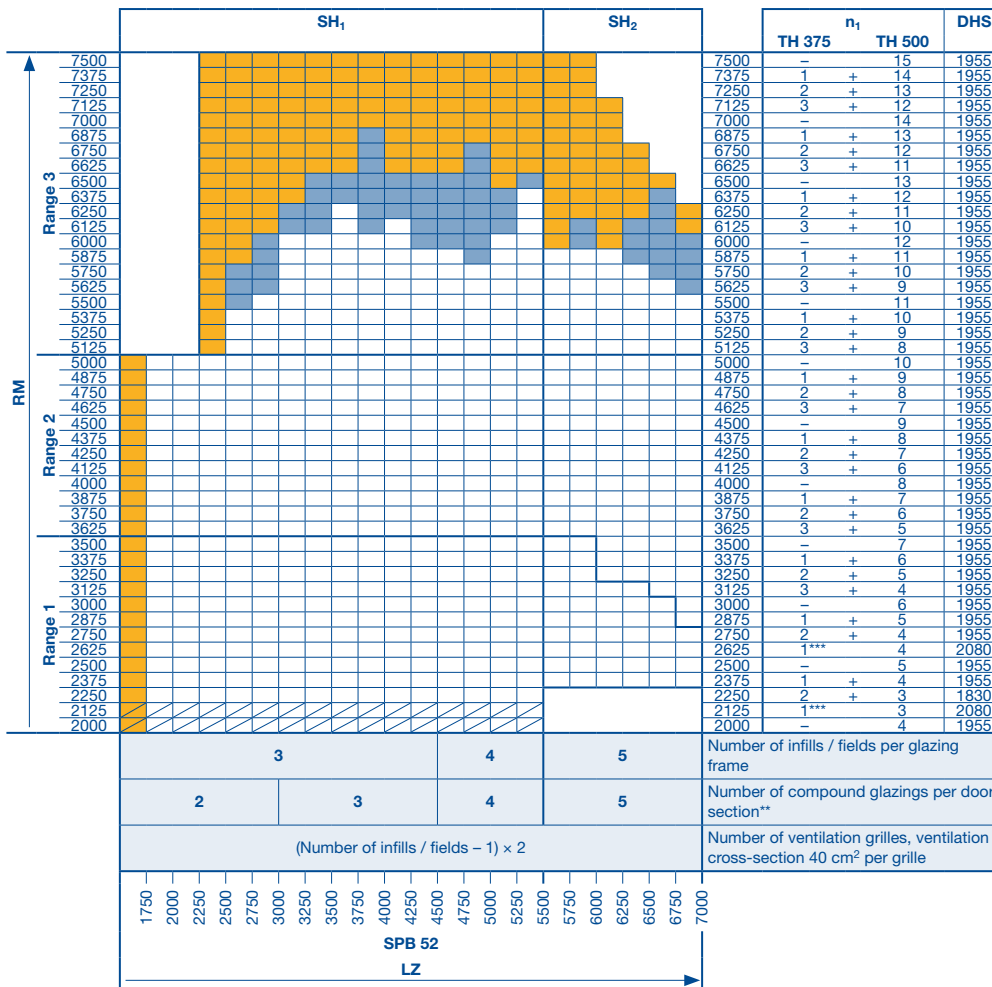

Notes:

- From LZ > 5500 mm bottom door section with deviating heights TH = 625 / 750 mm (made of 375 / 500 mm sections and 2 × 125 mm aluminium bottom profile).
- For a view of the matching appearance with doors without wicket door see pages 37 – 39.
- Number of glazings, matching series 40, see page 40.
- For versions with real glass infill in the wicket door, the threshold height SH₂ begins at LZ 4510 mm.

- On request
 - Versions with glazing frame A3, M3, S3, U3, LB, P on request
 - Range change
 - Glazings on request
- n₁ No. of door sections
DHS Clear passage heights of wicket door to grid height
RM Grid height
LZ Clear frame dimensions (from 1500)
SH₁ Threshold height (207)
SH₂ Threshold height (330), bottom door section with 250 mm aluminium bottom section, glazing from 625 mm
SPB Rail width
TH Door section height
DRH Lever height
DBS Wicket door clear passage width
*** TH = 625 mm

Glazing heights for matching external appearance

SPU F42 Stucco-textured / Micrograin

(Centre of window from FFL)

Door section heights 500, 625 and 750 mm

Glazing heights for matching external appearance of compound window type A, D and F.

RM	Glazing heights (centre of window from FFL)											
	1160	1285	1535	1660	1785	1910	2035	2160	2285	2410	2535	2660
7500		•			•							
7375	•	•		•	•							•
7250	•	•	•	•	•		•		•		•	•
7125	•	•	•	•	•	•	•	•	•	•	•	•
7000		•			•				•			
6875	•	•		•	•				•			•
6750	•	•		•	•		•		•		•	•
6625	•	•		•	•	•	•		•		•	•
6500		•			•				•			
6375	•	•		•	•			•	•			•
6250	•	•	•	•	•		•	•	•		•	•
6125	•	•	•	•	•	•	•	•	•	•	•	•
6000		•			•				•			
5875	•	•		•	•				•			•
5750	•	•	•	•	•		•		•		•	•
5625	•	•	•	•	•	•	•	•	•	•	•	•
5500		•			•				•			
5375	•	•		•	•			•	•			•
5250	•	•		•	•		•		•		•	•
5125	•	•		•	•	•	•		•	•	•	•
5000		•			•				•			
4875	•	•		•	•			•	•			•
4750	•	•	•	•	•		•		•		•	•
4625	•	•	•	•	•	•	•	•	•	•	•	•
4500		•			•				•			
4375	•	•		•	•				•			•
4250	•	•	•	•	•	•	•	•	•	•	•	•
4125	•	•	•	•	•	•	•	•	•	•	•	•
4000		•			•				•			
3875	•	•		•	•			•	•			•
3750	•	•		•	•		•		•		•	•
3625	•	•		•	•	•	•		•	•	•	•
3500		•			•				•			
3375	•	•		•	•				•			•
3250	•	•	•	•	•			•	•			•
3125		•	•	•	•			•	•			•
3000		•			•				•			
2875	•	•		•	•				•			•
2750	•	•	•	•	•				•		•	•
2625	•	•	•	•	•				•	•	•	•
2500									•			
2375				•				•				
2250	•	•					•					
2125	•					•						
2000					•							
1875				•								

RM Grid height

Dimensions of compound windows

Compound window **type A**, door section height 500, 625 and 750 mm

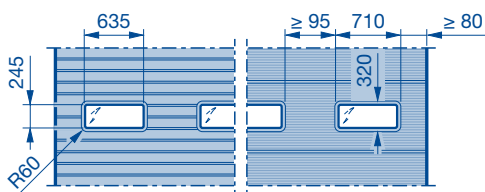

Compound window **type D**, door section height 500, 625 and 750 mm

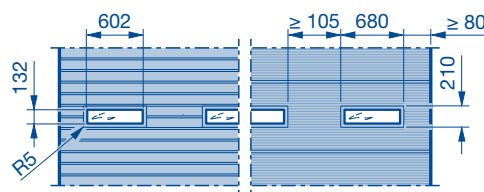

Compound window **type E**, door section height 625 and 750 mm

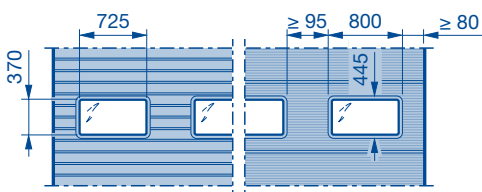

Compound window **type F**, door section height 500, 625 and 750 mm

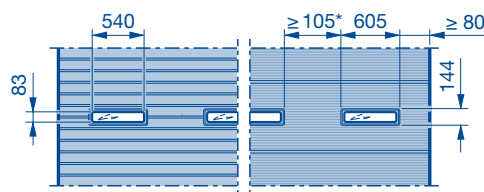

* With RC2 version min. 500 mm

Calculating the glazing heights

(Centre of window from FFL)

Door section heights 500, 625 and 750 mm

Calculating the glazing heights for compound windows type A, type D, type E and type F.

See door type for number of door sections and glazing areas. The illustrations correspond to a section depth of 42 mm.

Door section height 750 mm

Glazing height type A, D and F

- ① = $n_1 + 65 + 220$
- ② = $n_1 + 65 + 220 + 125$
- ③ = $n_1 + 65 + 220 + 250$
- ④ = $n_1 + 65 + 345$

Glazing height type E

- ① = $n_1 + 65 + 282,5$
- ② = $n_1 + 65 + 282,5 + 125$
- ④ = $n_1 + 65 + 345$

Note:
Glazing height type F with RC2 version requires a distance of min. 500 mm between the glazings!

Door section height 625 mm

Glazing height type A, D and F

- ① = $n_1 + 65 + 220$
- ② = $n_1 + 65 + 220 + 125$
- ③ = $n_1 + 65 + 282,5$

Glazing height type E

- ① = $n_1 + 65 + 282,5$
- ③ = $n_1 + 65 + 282,5$

Note:
Glazing height type F with RC2 version requires a distance of min. 500 mm between the glazings!

Door section height 500 mm

Glazing height type A, D and F

- ① = $n_1 + 65 + 220$

Glazing height type E
Not possible!

Note:
Glazing height type F with RC2 version requires a distance of min. 500 mm between the glazings!

Calculation example

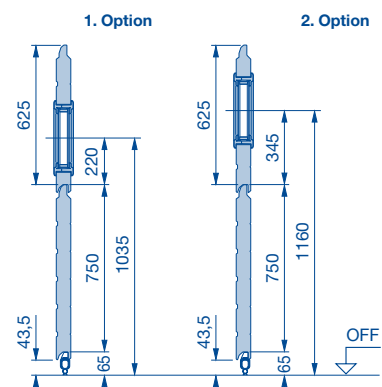

Given:

- Door type SPU F42; grid height (RM) = 3250 mm; glazing type A; position see below
- Door section 625 mm = 4 x
- Door section 750 mm = 1 x

Option	Door section / position	Glazing height
1	In the 2nd door section 625 mm at position 1	$750 + 65 + 220 = 1035$ mm from FFL
2	In the 2nd door section 625 mm at position 2	$750 + 65 + 220 + 125 = 1160$ mm from FFL
3	In the 3rd door section 625 mm at position 1	$750 + 625 + 65 + 220 = 1660$ mm from FFL
4	In the 3rd door section 625 mm at position 2	$750 + 625 + 65 + 220 + 125 = 1785$ mm from FFL
etc.		

* Stucco / Micrograin

MF Centre of window from FFL

n_1 No. of door sections

OFF Finished floor level (FFL)

Sectional door APU F42

Glazed aluminium sectional door with steel bottom section

External view

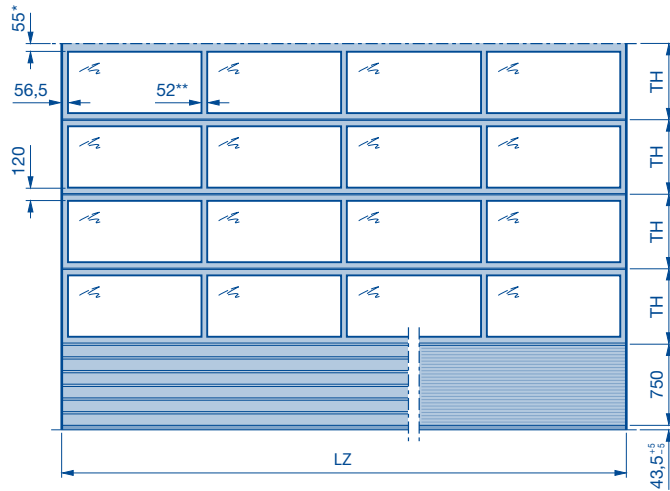

$$TH = \frac{\text{Door height - bottom section height} - 35}{\text{Number of glazing frames}}$$

- * On request 115 mm in order to match the appearance of a sectional door with wicket door with trip-free threshold with the same door height.
- ** Optionally with wide rail extrusions (91 mm)

Note:

- When using a shaft operator (installation example 5), the door locking is always opposite the operator side.
- For a view of the matching appearance with doors with wicket door see pages 37 – 39.
- Number of glazings, matching series 40, see page 40.

Size range

The validity tables with the size range shown are based on the standard door type version (see product description). In case of deviations, the valid size ranges in the product configurator must be taken into account. Any door width in 10 mm increments possible.

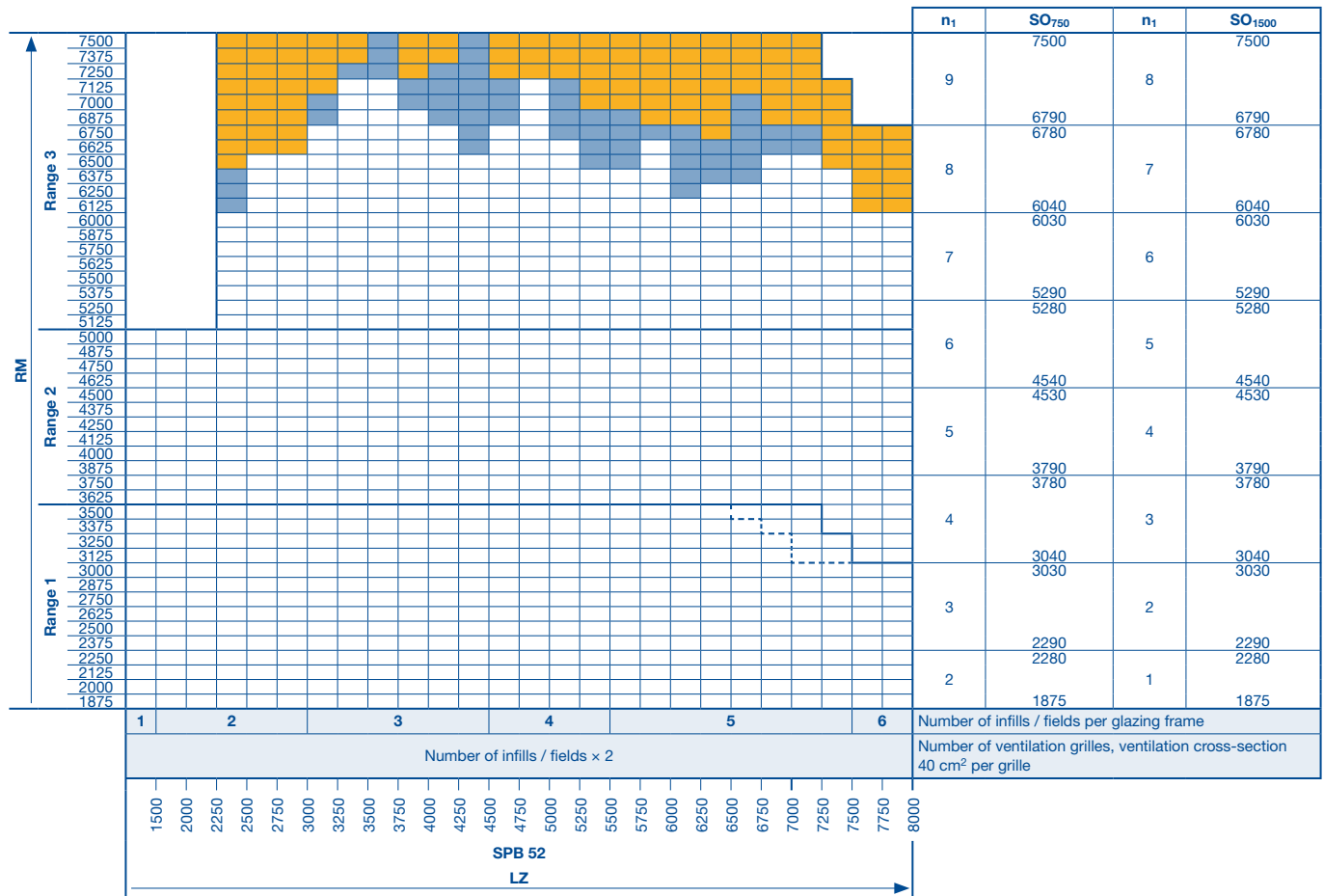

- On request
- Versions with glazing A3, M3, S3, U3, LB, P, XU on request
- Range change
- Range change with glazing A3, M3, S3, U3, LB, P, XU

- SO₇₅₀ Bottom section height 750 mm (standard)
- SO₁₅₀₀ Bottom section height 1500 mm
- RM Grid height
- LZ Clear frame dimensions (from 1200)
- SPB Rail width
- n₁ Number of glazing frames
- TH Door section height

Sectional door APU F42 with wicket door with trip-free threshold

Glazed aluminium sectional door with steel bottom section

Bottom section height 750

External view

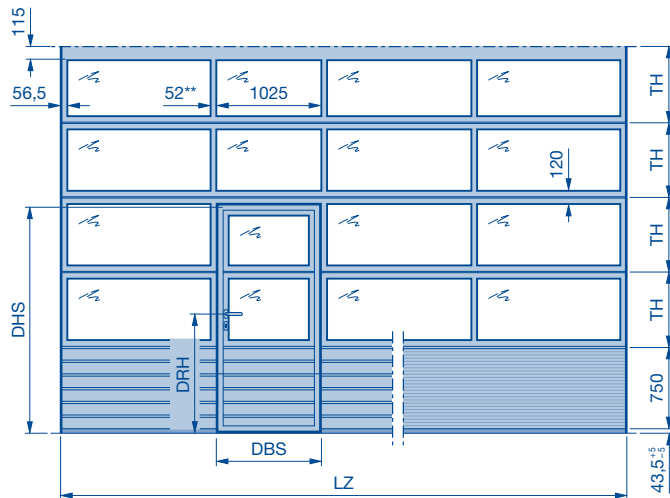

Lever height on request

Wicket door clear passage width (DBS) = 940 mm***

Clear passage height of wicket door (DHS) = $Sn_1 \times TH + (\text{bottom section height} - 45^*)$

Sn_1 Number of frames in the wicket door
 * Attention: If there is no frame above the wicket door, then - 90 instead of - 45.
 * Optionally with wide rail extrusions (91 mm)
 * For a door width of 1750 - 1840 mm, the clear passage width is 833 mm.
 For door widths below 1750 mm, the clear passage width (DBS) depends on the door width and is much smaller than standard dimensions.

Note:

- When using a shaft operator (installation example 5), the door locking is always opposite the operator side.
- For a view of the matching appearance with doors without wicket door see pages 37 – 39.
- Number of glazings, matching series 40, see page 40.

Size range

The validity tables with the size range shown are based on the standard door type version (see product description). In case of deviations, the valid size ranges in the product configurator must be taken into account. Any door width in 10 mm increments possible.

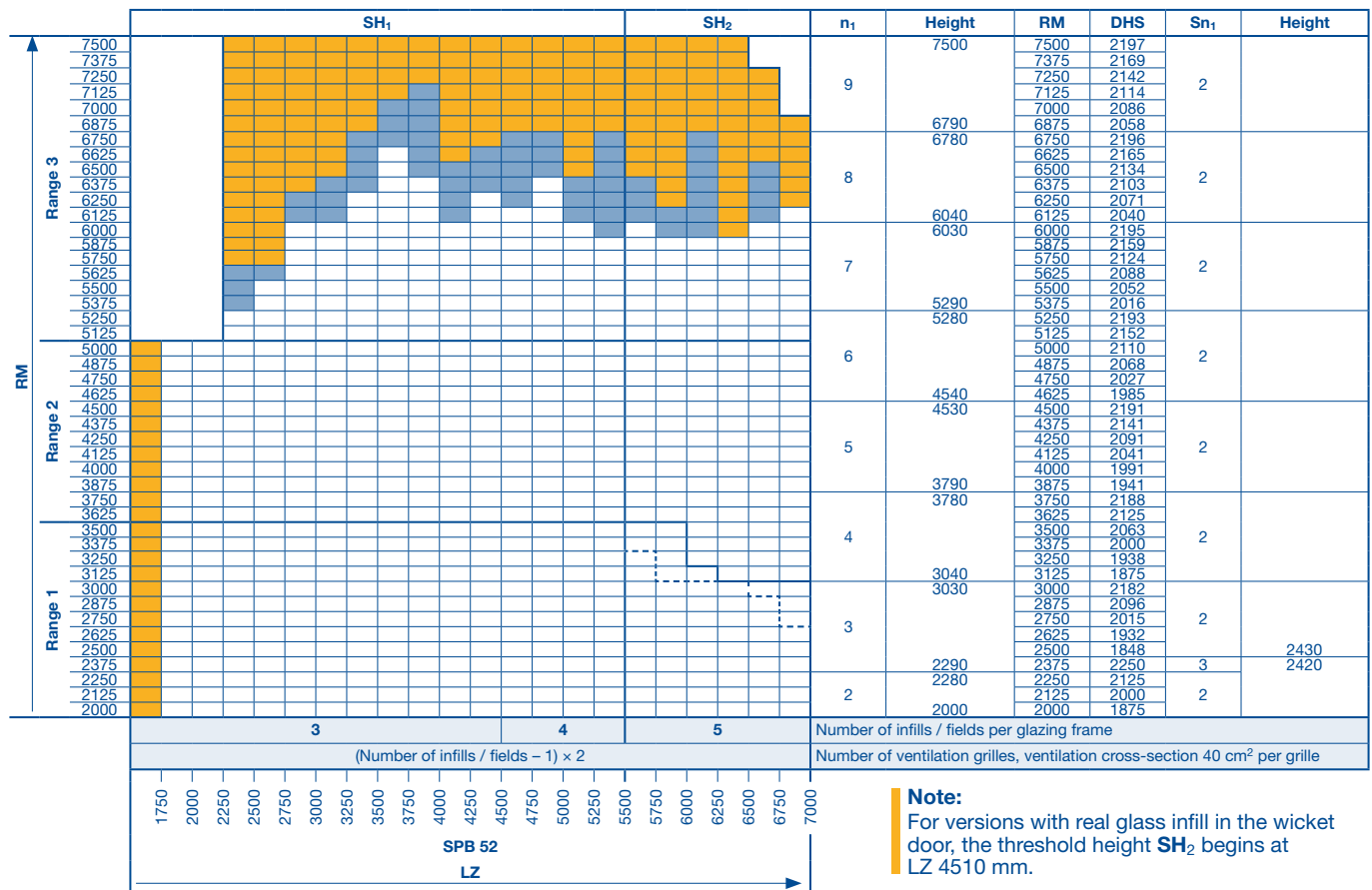

Note:

For versions with real glass infill in the wicket door, the threshold height SH₂ begins at LZ 4510 mm.

- On request
- Versions with glazing A3, M3, S3, U3, LB, P, XU on request
- Range change
- Range change with glazing A3, M3, S3, U3, LB, P, XU

- DHS Clear passage height of wicket door
- DBS Wicket door clear passage width
- LZ Clear frame dimensions (from 1500)
- DRH Lever height
- RM Grid height
- SPB Rail width

- SH₁ Threshold height (rising from 5 to 10)
- SH₂ Threshold height (approx. 13)
- n₁ Number of glazing frames
- Sn₁ Number of glazing frames in the wicket door
- TH Door section height

Sectional door APU F42 with wicket door and threshold rail

Glazed aluminium sectional door with steel bottom section
Bottom section height 750

External view

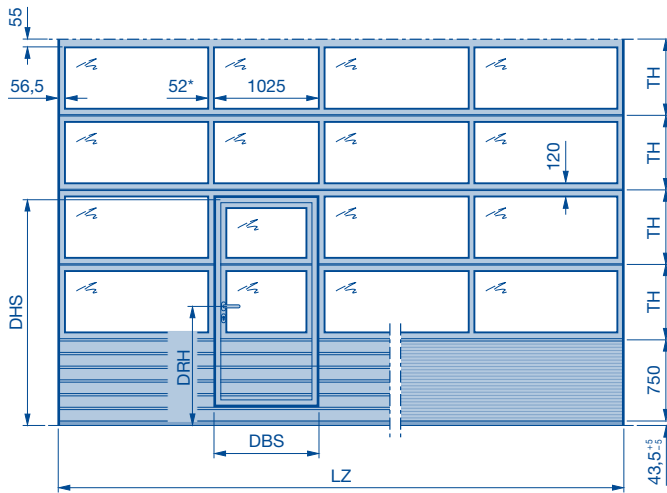

Lever height on request

Wicket door clear passage width (DBS) = 940 mm**

Clear passage height of wicket door (DHS) = $S_{n1} \times TH$ + (bottom section height - 45)

S_{n1} Number of frames in the wicket door
 · Optionally with wide rail extrusions (91 mm)
 · For a door width of 1750 - 1840 mm, the clear passage width is 833 mm.
 For door widths below 1750 mm, the clear passage width (DBS) depends on the door width and is much smaller than standard dimensions.

Note:

- When using a shaft operator (installation example 5), the door locking is always opposite the operator side.
- For a view of the matching appearance with doors without wicket door see pages 37 - 39.
- Number of glazings, matching series 40, see page 40.

Size range

The validity tables with the size range shown are based on the standard door type version (see product description). In case of deviations, the valid size ranges in the product configurator must be taken into account. Any door width in 10 mm increments possible.

RM	SH ₁	SH ₂	n ₁	Height	RM	DHS	S _{n1}	Height																			
									RM																		
7500			9	7500	7500	2197	2																				
7375				7375	7375	2169																					
7250				7250	2142																						
7125				7125	2114																						
7000				7000	2086																						
6875				6875	2058																						
6750			8	6790	6750	2196	2																				
6625				6780	6625	2165																					
6500				6500	2134																						
6375				6375	2103																						
6250				6250	2071																						
6125			7	6040	6125	2040	2																				
6000				6030	6000	2195																					
5875				5875	2159																						
5750				5750	2124																						
5625				5625	2088																						
5500			6	5290	5500	2052	2																				
5375				5280	5375	2016																					
5250				5250	2193																						
5125				5125	2152																						
5000			5	5000	2110	2																					
4875				4540	4875		2068																				
4750				4750	2027																						
4625				4625	1985																						
4500			4	4530	4500	2191	2																				
4375				3790	4375	2141																					
4250				4250	2091																						
4125				4125	2041																						
4000				4000	1991																						
3875			3	3780	3875	1941	2																				
3750				3040	3750	2188																					
3625				3625	2125																						
3500			2	3500	2063	2																					
3375				3030	3375		2000																				
3250				3250	1938																						
3125				3125	1875																						
3000				3000	2182																						
2875			2	2875	2096	2																					
2750				2750	2015																						
2625				2625	1932																						
2500				2500	1848			2430																			
2375				2375	2295	3		2420																			
2250			2	2280	2250	2170	2																				
2125				2000	2125	2045																					
2000				2000	1920																						
			3	Number of infills / fields per glazing frame																							
			4	(Number of infills / fields - 1) × 2																							
			5	Number of ventilation grilles, ventilation cross-section 40 cm ² per grille																							
				1750	2000	2250	2500	2750	3000	3250	3500	3750	4000	4250	4500	4750	5000	5250	5500	5750	6000	6250	6500	6750	7000		
				SPB 52																							
				LZ																							

Note:

For versions with real glass infill in the wicket door, the threshold height **SH₂** begins at LZ 4510 mm.

- On request
- Versions with glazing A3, M3, S3, U3, LB, P, XU on request
- Range change
- Range change with glazing A3, M3, S3, U3, LB, P, XU

- DHS** Clear passage height of wicket door
- DBS** Wicket door clear passage width
- DRH** Lever height
- LZ** Clear frame dimensions (from 1500)
- RM** Grid height
- SPB** Rail width

- SH₁** Threshold height (207)
- SH₂** Threshold height (330)
- n₁** Number of glazing frames
- S_{n1}** Number of glazing frames in the wicket door
- TH** Door section height

Sectional door APU F42 Thermo with wicket door and threshold rail

Glazed aluminium sectional door with thermal break, with steel bottom section

Bottom section height 750

External view

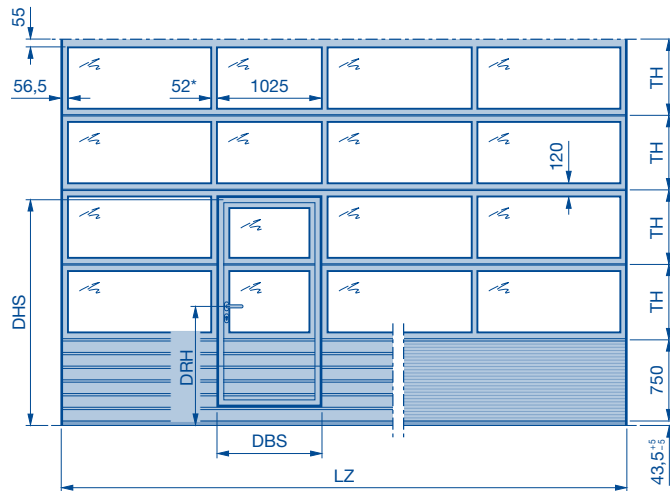

Lever height on request

Wicket door clear passage width (DBS) = 940 mm**

Clear passage height of wicket door (DHS) = $Sn_1 \times TH$ + (bottom section height - 45)

Sn_1 Number of frames in the wicket door

* Optionally with wide rail extrusions (91 mm)

** For a door width of 1750 - 1840 mm, the clear passage width is 833 mm.

For door widths below 1750 mm, the clear passage width (DBS) depends on the door width and is much smaller than standard dimensions.

Note:

- When using a shaft operator (installation example 5), the door locking is always opposite the operator side.
- For a view of the matching appearance with doors without wicket door see pages 37 - 39.
- Number of glazings, matching series 40, see page 40.

Size range

The validity tables with the size range shown are based on the standard door type version (see product description). In case of deviations, the valid size ranges in the product configurator must be taken into account. Any door width in 10 mm increments possible.

RM	SH ₁	SH ₂	n ₁	Height	RM	DHS	Sn ₁	Height
7500			9	7500	7500	2197	2	
7375				7375	7375	2169		
7250			8	7250	7250	2142	2	
7125				7125	7125	2114		
7000			7	7000	7000	2086	2	
6875				6875	6875	2058		
6750			6	6750	6750	2196	2	
6625				6625	6625	2165		
6500			5	6500	6500	2134	2	
6375				6375	6375	2103		
6250			4	6250	6250	2071	2	
6125				6125	6125	2040		
6000			3	6000	6000	2195	2	
5875				5875	5875	2159		
5750			2	5750	5750	2124	2	
5625				5625	5625	2088		
5500			1	5500	5500	2052	2	
5375				5375	5375	2016		
5250			9	5290	5250	2193	2	
5125				5280	5125	2152		
5000			8	5000	5000	2110	2	
4875				4875	4875	2068		
4750			7	4750	4750	2027	2	
4625				4625	4625	1985		
4500			6	4540	4500	2191	2	
4375				4530	4375	2141		
4250			5	4250	4250	2091	2	
4125				4125	4125	2041		
4000			4	4000	4000	1991	2	
3875				3790	3875	1941		
3750			3	3780	3750	2188	2	
3625				3625	3625	2125		
3500			2	3500	3500	2063	2	
3375				3375	3375	2000		
3250			1	3250	3250	1938	2	
3125				3125	3125	1875		
3000			9	3040	3000	2182	2	
2875				3030	2875	2096		
2750			8	2750	2750	2015	2	
2625				2625	2625	1932		
2500			7	2500	2500	1848	2	
2375				2375	2375	2295		
2250			6	2290	2250	2170	3	2430
2125				2280	2125	2045		
2000			5	2000	2000	1920	2	2420

Note:

For versions with real glass infill in the wicket door, the threshold height **SH₂** begins at LZ 4510 mm.

- On request
- Versions with glazing A3, M3, S3, U3, LB, P, XU on request
- Range change
- Range change with glazing A3, M3, S3, U3, LB, P, XU

- DHS** Clear passage height of wicket door
- DBS** Wicket door clear passage width
- DRH** Lever height
- LZ** Clear frame dimensions (from 1500)
- RM** Grid height
- SPB** Rail width

- SH₁** Threshold height (207)
- SH₂** Threshold height (330)
- n₁** Number of glazing frames
- Sn₁** Number of glazing frames in the wicket door
- TH** Door section height

Sectional door APU F42 Thermo with wicket door with trip-free threshold

Glazed aluminium sectional door with thermal break, with steel bottom section

Bottom section height 1500

External view

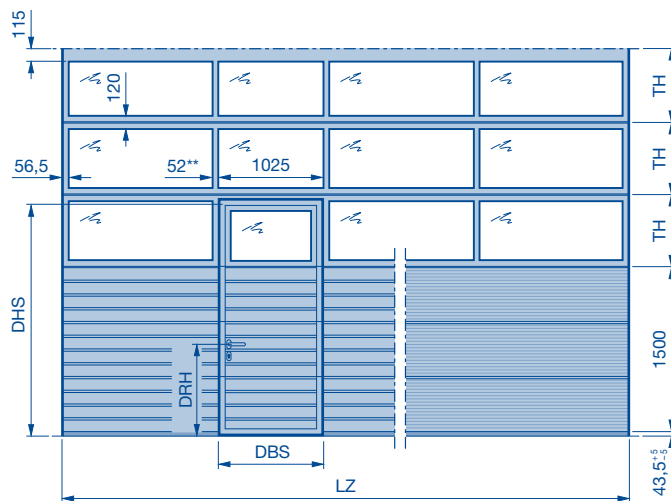

Lever height (DRH):

$LZ \leq 6000 = 1085,5$

$LZ > 6000 = 835,5$

Wicket door clear passage width (DBS) = 940 mm***

Clear passage height of wicket door (DHS) = $Sn_1 \times TH + (\text{bottom section height} - 45^*)$

Sn_1 Number of frames in the wicket door

* Attention: If there is no frame above the wicket door, then - 90 instead of - 45.

** Optionally with wide rail extrusions (Ø1 mm)

*** For a door width of 1750 - 1840 mm, the clear passage width is 833 mm.

For door widths below 1750 mm, the clear passage width (DBS) depends on the door width and is much smaller than standard dimensions.

Note:

- When using a shaft operator (installation example 5), the door locking is always opposite the operator side.
- For a view of the matching appearance with doors without wicket door see pages 37 – 39.
- Number of glazings, matching series 40, see page 40.

Size range

The validity tables with the size range shown are based on the standard door type version (see product description). In case of deviations, the valid size ranges in the product configurator must be taken into account. Any door width in 10 mm increments possible.

RM	SH ₁		SH ₂		n ₁	Height	RM	DHS	Sn ₁
	3	4	5	6					
7500					8	7500	7500	2201	1
7375							7375	2185	
7250					7	6790	7250	2169	1
7125							7125	2154	
7000					6	6040	7000	2138	1
6875							6875	2123	
6750					5	4540	6750	2200	1
6625							6625	2182	
6500					4	3790	6500	2164	1
6375							6375	2146	
6250					3	3040	6250	2129	1
6125							6125	2111	
6000					2	2290	6000	2199	1
5875							5875	2178	
5750					1	2000	5750	2158	1
5625							5625	2137	
5500					8	7500	5500	2116	1
5375							5375	2095	
5250					7	6780	5250	2198	1
5125							5125	2173	
5000					6	6030	5000	2148	1
4875							4875	2123	
4750					5	4530	4750	2098	1
4625							4625	2073	
4500					4	3780	4500	2196	1
4375							4375	2165	
4250					3	3030	4250	2134	1
4125							4125	2103	
4000					2	2280	4000	2071	1
3875							3875	2040	
3750					1	2000	3750	2193	1
3625							3625	2152	
3500					8	7500	3500	2110	1
3375							3375	2068	
3250					7	6780	3250	2027	1
3125							3125	1985	
3000					6	6030	3000	2188	1
2875							2875	2125	
2750					5	4530	2750	2063	1
2625							2625	2000	
2500					4	3780	2500	1938	1
2375							2375	1875	
2250					3	3030	2250	2125	1
2125							2125	2000	
2000					1	2000	2000	1875	

Note:

For versions with real glass infill in the wicket door, the threshold height SH₂ begins at LZ 4510 mm.

- On request
- Versions with glazing A3, M3, S3, U3, LB, P, XU on request
- Range change
- Range change with glazing A3, M3, S3, U3, LB, P, XU

- DHS Clear passage height of wicket door
- DBS Wicket door clear passage width
- LZ Clear frame dimensions (from 1500)
- RM Grid height
- SPB Rail width
- SH₁ Threshold height (rising from 5 to 10)
- SH₂ Threshold height (approx. 13)

- n₁ Number of glazing frames
- Sn₁ Number of glazing frames in the wicket door
- TH Door section height

Sectional door APU F42 Thermo with wicket door and threshold rail

Glazed aluminium sectional door with thermal break, with steel bottom section

Bottom section height 1500

External view

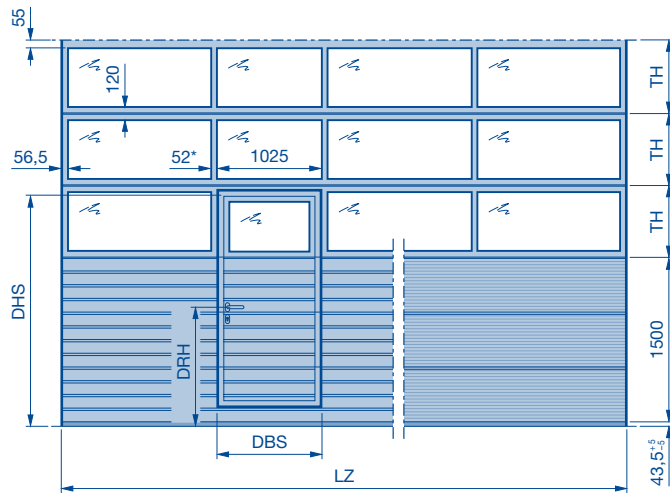

Lever height on request

Wicket door clear passage width (DBS) = 940 mm**

Clear passage height of wicket door (DHS) = $S_{n1} \times TH +$ (bottom section height - 45)

S_{n1} Number of frames in the wicket door

* Optionally with wide rail extrusions (91 mm)

** For a door width of 1750 - 1840 mm, the clear passage width is 833 mm.

For door widths below 1750 mm, the clear passage width (DBS) depends on the door width and is much smaller than standard dimensions.

Note:

- When using a shaft operator (installation example 5), the door locking is always opposite the operator side.
- From LZ > 5500 mm, the bottom door section consists of a 375 / 500 mm section and 2 x 125 mm aluminium bottom profile.
- For a view of the matching appearance with doors without wicket door see pages 37 - 39.
- Number of glazings, matching series 40, see page 40.

Size range

The validity tables with the size range shown are based on the standard door type version (see product description). In case of deviations, the valid size ranges in the product configurator must be taken into account. Any door width in 10 mm increments possible.

RM	Range 3	Range 2	Range 1	SH ₁		SH ₂	n ₁	Height	RM	DHS	S _{n1}
				3	4	5					
7500							8	7500	7500	2201	1
7375									7375	2185	
7250							7	6790	7250	2169	1
7125									7125	2154	
7000							6	6030	7000	2138	1
6875									6875	2123	
6750							5	4540	6750	2200	1
6625									6625	2182	
6500							4	3780	6500	2164	1
6375									6375	2146	
6250							3	3040	6250	2129	1
6125									6125	2111	
6000							2	2280	6000	2199	1
5875									5875	2178	
5750							1	2000	5750	2158	1
5625									5625	2137	
5500								5500	2116		
5375								5375	2095		
5250								5250	2198		
5125								5125	2173		
5000								5000	2148		
4875								4875	2123		
4750								4750	2098		
4625								4625	2073		
4500								4500	2196		
4375								4375	2165		
4250								4250	2134		
4125								4125	2103		
4000								4000	2071		
3875								3875	2040		
3750								3750	2193		
3625								3625	2152		
3500								3500	2110		
3375								3375	2068		
3250								3250	2027		
3125								3125	1985		
3000								3000	2188		
2875								2875	2125		
2750								2750	2063		
2625								2625	2000		
2500								2500	1938		
2375								2375	1875		
2250								2250	2170		
2125								2125	2045		
2000								2000	1920		

Note:

For versions with real glass infill in the wicket door, the threshold height SH₂ begins at LZ 4510 mm.

On request

Versions with glazing A3, M3, S3, U3, LB, P, XU on request

Range change

Range change with glazing A3, M3, S3, U3, LB, P, XU

DHS Clear passage height of wicket door

DBS Wicket door clear passage width

DRH Lever height

LZ Clear frame dimensions (from 1500)

RM Grid height

SPB Rail width

SH₁ Threshold height (207)

SH₂ Threshold height (330)

n₁ Number of glazing frames

S_{n1} Number of glazing frames in the wicket door

TH Door section height

Sectional door ALR F42

Glazed aluminium sectional door

External view

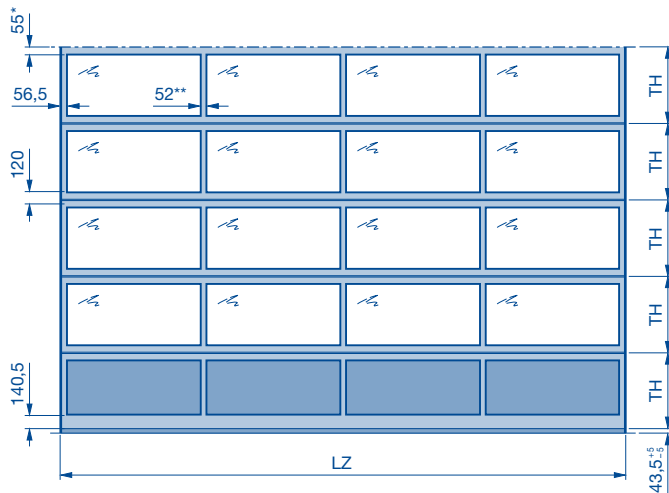

$$TH = \frac{\text{Door height} - 35}{\text{Number of glazing frames}}$$

- * On request 115 mm in order to match the appearance of a sectional door with wicket door with trip-free threshold with the same door height.
- ** Optionally with wide rail extrusions (91 mm)

Note:

- When using a shaft operator (installation example 5), the door locking is always opposite the operator side.
- For door widths from 5510 mm, diagonal struts are fitted into the bottom door section (not visible with closed infills).
- For a view of the matching appearance with doors with wicket door see pages 37 – 39.
- Number of glazings, matching series 40, see page 40.

Size range

The validity tables with the size range shown are based on the standard door type version (see product description). In case of deviations, the valid size ranges in the product configurator must be taken into account. Any door width in 10 mm increments possible.

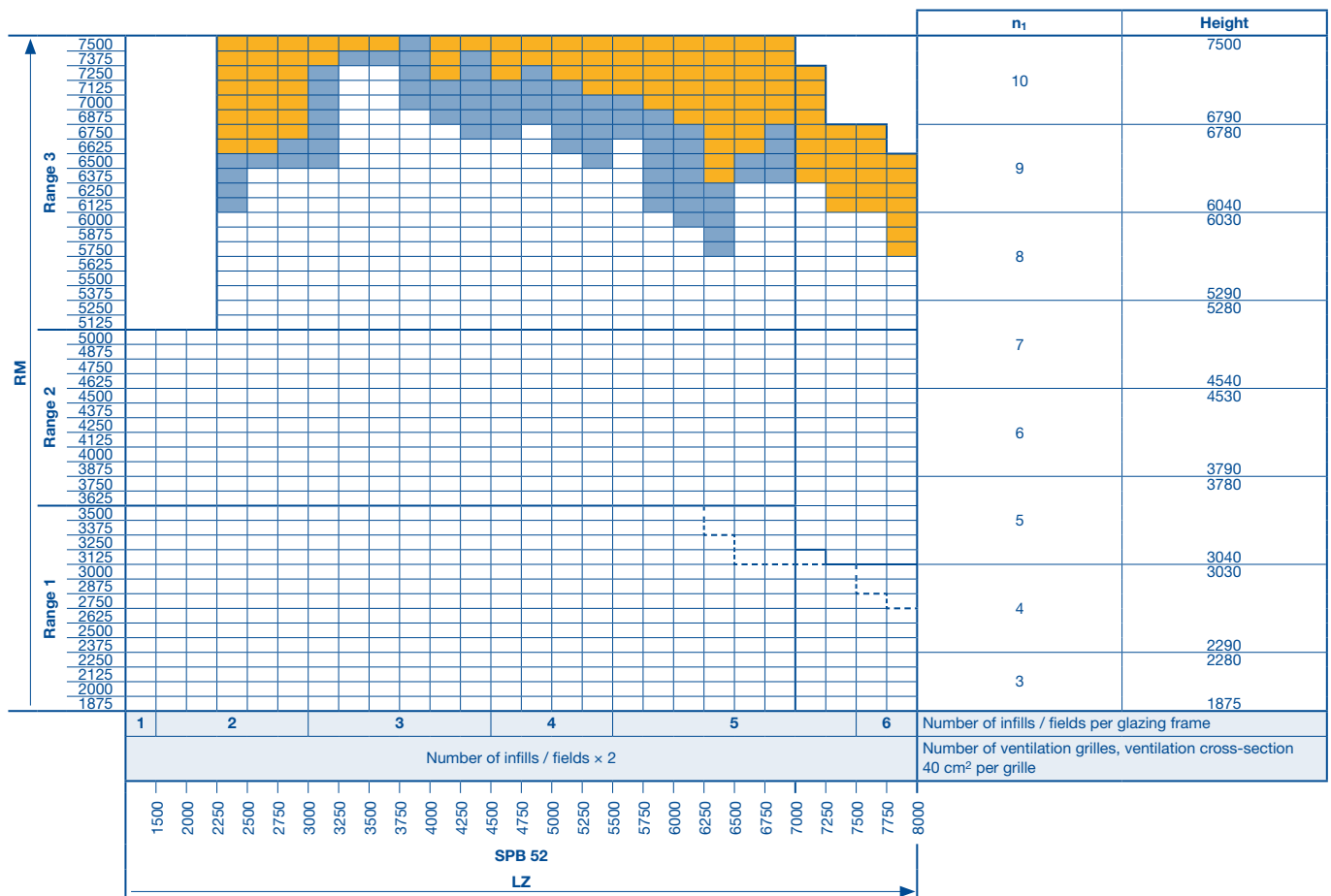

- On request
- Versions with glazing A3, M3, S3, U3, LB, P, XU on request
- Range change
- Range change with glazing A3, M3, S3, U3, LB, P, XU

- RM** Grid height
- LZ** Clear frame dimensions (from 1200)
- SPB** Rail width
- n₁** Number of glazing frames
- TH** Door section height

Sectional door ALR F42 with wicket door with trip-free threshold

Glazed aluminium sectional door

External view

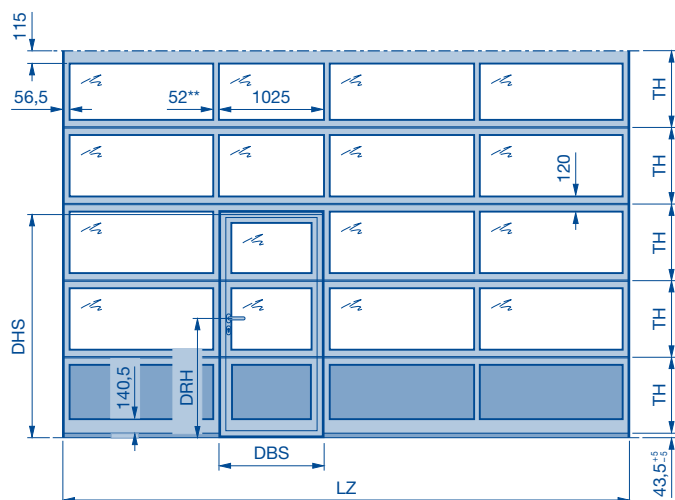

Lever height on request

Wicket door clear passage width (DBS) = 940 mm***

Clear passage height of wicket door (DHS) = $Sn_1 \times TH - 45^*$

- Sn_1 Number of frames in the wicket door
- * Attention: If there is no frame above the wicket door, then - 90 instead of - 45.
- ** Optionally with wide rail extrusions (91 mm)
- *** For a door width of 1750 - 1840 mm, the clear passage width is 833 mm.
- For door widths below 1750 mm, the clear passage width (DBS) depends on the door width and is much smaller than standard dimensions.

Note:

- When using a shaft operator (installation example 5), the door locking is always opposite the operator side.
- For door widths from 5510 mm (from 4510 mm with real glass infill in the wicket door), diagonal struts are fitted into the bottom door section – not visible with closed inflills.
- For a view of the matching appearance with doors without wicket door see pages 37 – 39.
- Number of glazings, matching series 40, see page 40.

Size range

The validity tables with the size range shown are based on the standard door type version (see product description). In case of deviations, the valid size ranges in the product configurator must be taken into account. Any door width in 10 mm increments possible.

RM	SH ₁	SH ₂	n ₁	Height	RM	DHS	Sn ₁	Height														
									3	4	5											
7500			10	7500	7500	2195	3															
7375				7375	7375	2157																
7250				7250	7250	2120																
7125				7125	7125	2082																
7000				7000	7000	2045																
6875				6875	6875	2007																
6750				6750	6750	2193	3															
6625				6625	6625	2152																
6500				6500	6500	2110																
6375				6375	6375	2068																
6250				6250	6250	2027																
6125				6125	6125	1985																
6000				6000	6000	2192	3															
5875				5875	5875	2145																
5750				5750	5750	2098																
5625				5625	5625	2051																
5500				5500	5500	2004																
5375				5375	5375	1958																
5250				5250	5250	1910																
5125				5125	5125	2136	3															
5000				5000	5000	2083																
4875				4875	4875	2029																
4750				4750	4750	1976																
4625				4625	4625	1922																
4500				4540	4500	2188																
4375				4530	4375	2125																
4250					4250	2063																
4125					4125	2000	3															
4000					4000	1938																
3875					3875	1875																
3750					3780	2184																
3625					3625	2109																
3500					3500	2034																
3375					3375	1959	3															
3250					3250	1884																
3125					3125	1809																
3000					3040	2179																
2875					3030	2085																
2750						2750	1991															
2625						2625	1898															
2500						2500	1804	2500														
2375						2375	2250	2490														
2250						2250	2125															
2125						2125	2000															
2000						2000	1875															
	3	4	5																			
	(Number of inflills / fields - 1) × 2																					
	Number of ventilation grilles, ventilation cross-section 40 cm ² per grille																					
	1750	2000	2250	2500	2750	3000	3250	3500	3750	4000	4250	4500	4750	5000	5250	5500	5750	6000	6250	6500	6750	7000
	SPB 52																					
	LZ																					

Note:

For versions with real glass infill in the wicket door, the threshold height **SH₂** begins at LZ 4510 mm.

 On request	DHS Clear passage height of wicket door	SH₁ Threshold height (rising from 5 to 10)
 Versions with glazing A3, M3, S3, U3, LB, P, XU on request	DBS Wicket door clear passage width	SH₂ Threshold height (approx. 13)
 Range change	DRH Lever height	n₁ Number of glazing frames
 Range change with glazing A3, M3, S3, U3, LB, P, XU	LZ Clear frame dimensions (from 1500)	Sn₁ Number of glazing frames in the wicket door
	RM Grid height	TH Door section height
	SPB Rail width	

Sectional door ALR F42 Thermo

Glazed aluminium sectional door with thermal break

External view

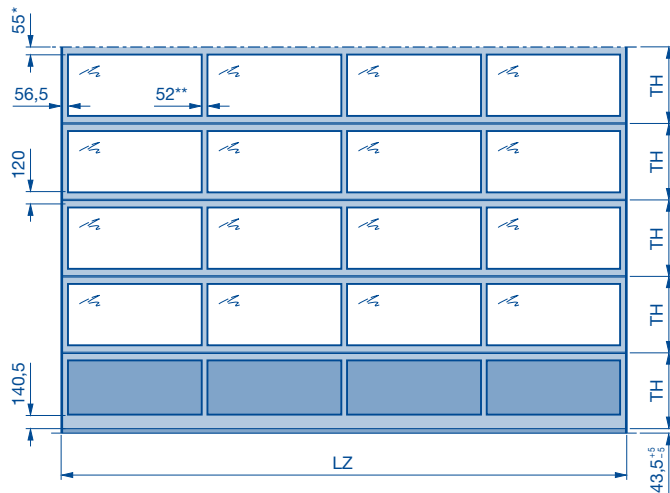

$$TH = \frac{\text{Door height}-35}{\text{Number of glazing frames}}$$

- * On request 115 mm in order to match the appearance of a sectional door with wicket door with trip-free threshold with the same door height.
- ** Optionally with wide rail extrusions (91 mm)

Note:

- When using a shaft operator (installation example 5), the door locking is always opposite the operator side.
- For door widths from 5510 mm, diagonal struts are fitted into the bottom door section (not visible with closed infills).
- For a view of the matching appearance with doors with wicket door see pages 37–39.
- Number of glazings, matching series 40, see page 40.

Size range

The validity tables with the size range shown are based on the standard door type version (see product description). In case of deviations, the valid size ranges in the product configurator must be taken into account. Any door width in 10 mm increments possible.

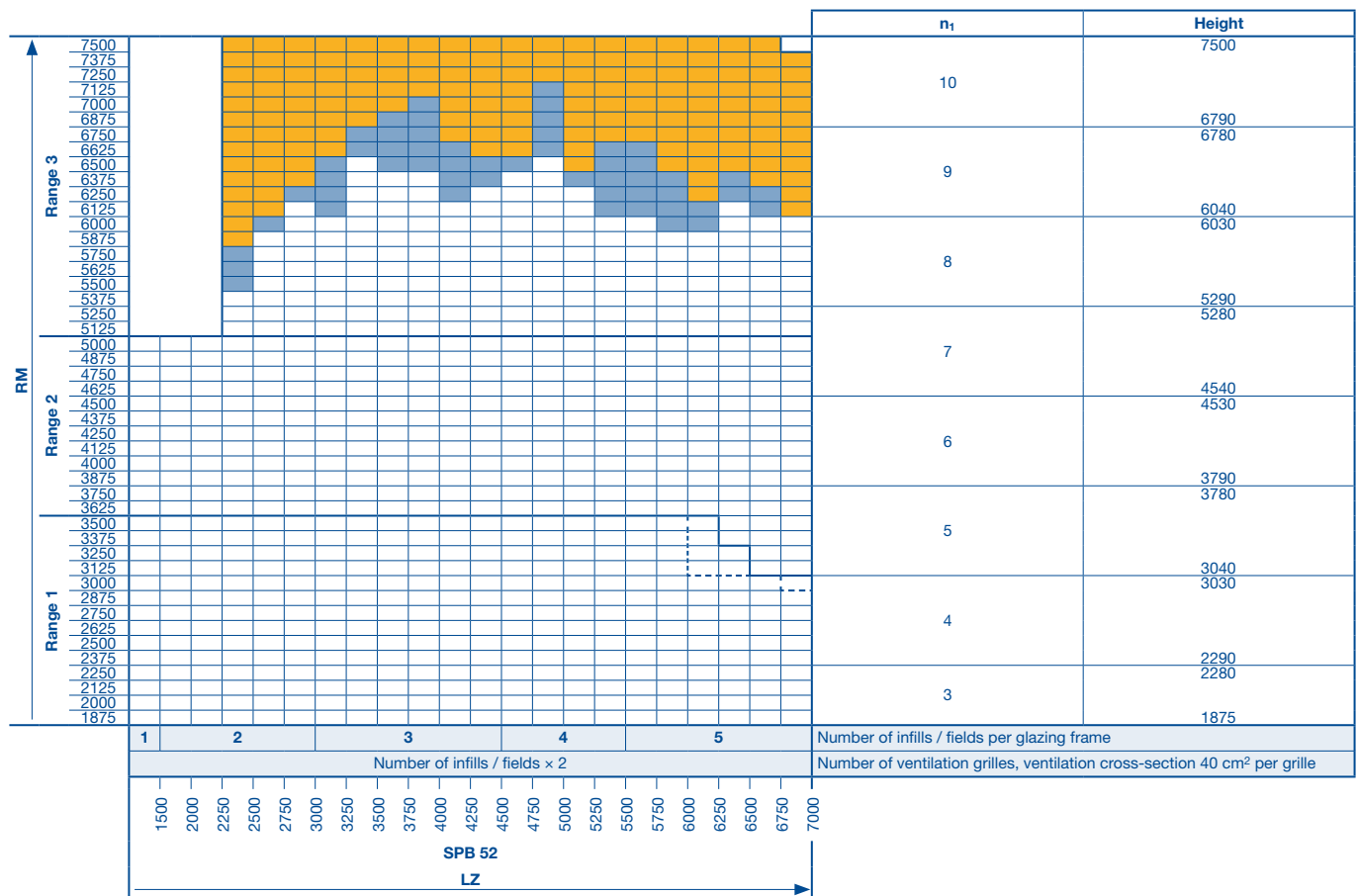

- On request
- Versions with glazing A3, M3, S3, U3, LB, P, XU on request
- Range change
- Range change with glazing A3, M3, S3, U3, LB, P, XU

- RM Grid height
- LZ Clear frame dimensions (from 1200)
- SPB Rail width
- n₁ Number of glazing frames
- TH Door section height

Sectional door ALR F42 Thermo with wicket door with trip-free threshold

Glazed aluminium sectional door with thermal break

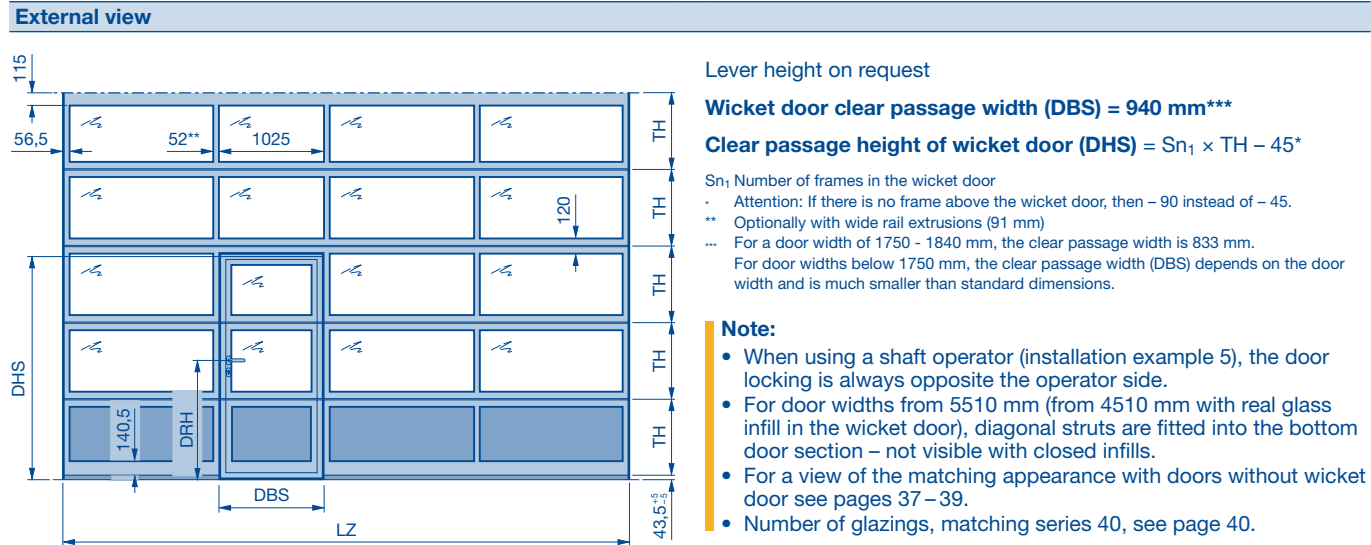

Size range

The validity tables with the size range shown are based on the standard door type version (see product description). In case of deviations, the valid size ranges in the product configurator must be taken into account. Any door width in 10 mm increments possible.

RM	SH ₁	SH ₂	n ₁	Height	RM	DHS	Sn ₁	Height
7500				7500	7500	2195		
7375				7375	7375	2157		
7250			10	7250	7250	2120	3	
7125				7125	7125	2082		
7000				7000	7000	2045		
6875				6875	6875	2007		
6750				6750	6750	1970		
6625				6625	6625	1932		
6500				6500	6500	1895		
6375				6375	6375	1857		
6250				6250	6250	1820		
6125				6125	6125	1782		
6000				6000	6000	1745		
5875				5875	5875	1707		
5750				5750	5750	1670		
5625				5625	5625	1632		
5500				5500	5500	1595		
5375				5375	5375	1557		
5250				5250	5250	1520		
5125				5125	5125	1482		
5000				5000	5000	1445		
4875				4875	4875	1407		
4750				4750	4750	1370		
4625				4625	4625	1332		
4500				4500	4500	1295		
4375				4375	4375	1257		
4250				4250	4250	1220		
4125				4125	4125	1182		
4000				4000	4000	1145		
3875				3875	3875	1107		
3750				3750	3750	1070		
3625				3625	3625	1032		
3500				3500	3500	995		
3375				3375	3375	957		
3250				3250	3250	920		
3125				3125	3125	882		
3000				3000	3000	845		
2875				2875	2875	807		
2750				2750	2750	770		
2625				2625	2625	732		
2500				2500	2500	695		
2375				2375	2375	657		
2250				2250	2250	620		
2125				2125	2125	582		
2000				2000	2000	545		
	3	4	5					
	(Number of inflills / fields - 1) × 2		Number of ventilation grilles, ventilation cross-section 40 cm ² per grille					
	1750	2000	2250	2500	2750	3000	3250	3500
	3750	4000	4250	4500	4750	5000	5250	5500
	5750	6000	6250	6500	6750	7000		
	SPB 52 LZ							

Note:
For versions with real glass infill in the wicket door, the threshold height SH₂ begins at LZ 4510 mm.

 On request	DHS Clear passage height of wicket door	SH₁ Threshold height (rising from 5 to 10)
 Versions with glazing A3, M3, S3, U3, LB, P, XU on request	DBS Wicket door clear passage width	SH₂ Threshold height (approx. 13)
 Range change	DRH Lever height	n₁ Number of glazing frames
 Range change with glazing A3, M3, S3, U3, LB, P, XU	LZ Clear frame dimensions (from 1500)	Sn₁ Number of glazing frames in the wicket door
	RM Grid height	TH Door section height
	SPB Rail width	

Sectional door ALR F42 Thermo with wicket door and threshold rail

Glazed aluminium sectional door with thermal break

External view

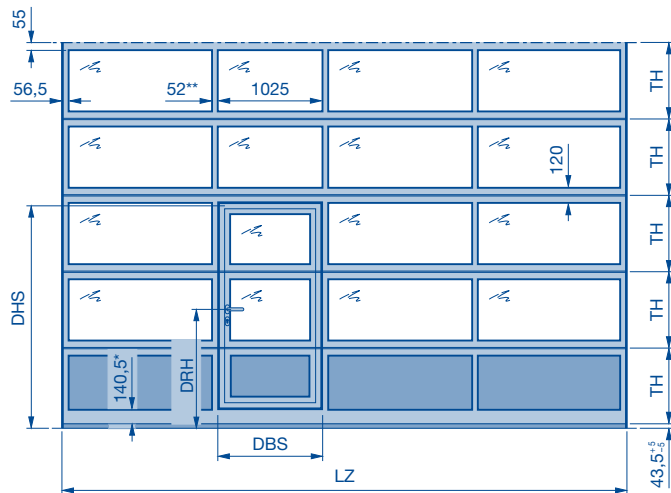

Lever height on request

Wicket door clear passage width (DBS) = 940 mm***

Clear passage height of wicket door (DHS) = $Sn_1 \times TH - 45$

Sn_1 Number of frames in the wicket door

- 265.5 with SH_2

** Optionally with wide rail extrusions (91 mm)

*** For a door width of 1750 - 1840 mm, the clear passage width is 833 mm.

For door widths below 1750 mm, the clear passage width (DBS) depends on the door width and is much smaller than standard dimensions.

Note:

- When using a shaft operator (installation example 5), the door locking is always opposite the operator side.
- For a view of the matching appearance with doors without wicket door see pages 37 – 39.
- Number of glazings, matching series 40, see page 40.

Size range

The validity tables with the size range shown are based on the standard door type version (see product description). In case of deviations, the valid size ranges in the product configurator must be taken into account. Any door width in 10 mm increments possible.

RM	SH ₁	SH ₂	n ₁	Height	RM	DHS	Sn ₁	Height
7500			10	7500	7500	2195	3	
7375				7375	7375	2157		
7250			9	7250	7250	2120	3	
7125				7125	7125	2082		
7000			8	7000	7000	2045	3	
6875				6875	6875	2007		
6750			7	6750	6750	2193	3	
6625				6625	6625	2152		
6500			6	6500	6500	2110	3	
6375				6375	6375	2068		
6250			5	6250	6250	2027	3	
6125				6125	6125	1985		
6000			4	6000	6000	2192	3	
5875				5875	5875	2145		
5750			3	5750	5750	2098	3	
5625				5625	5625	2051		
5500			2	5500	5500	2004	3	
5375				5375	5375	1958		
5250			1	5250	5250	2190	3	
5125				5125	5125	2136		
5000			0	5000	5000	2083	3	
4875				4875	4875	2029		
4750			0	4750	4750	1976	3	
4625				4625	4625	1922		
4500			0	4500	4500	2188	3	
4375				4375	4375	2125		
4250			0	4250	4250	2063	3	
4125				4125	4125	2000		
4000			0	4000	4000	1938	3	
3875				3875	3875	1875		
3750			0	3750	3750	2184	3	
3625				3625	3625	2109		
3500			0	3500	3500	2034	3	
3375				3375	3375	1959		
3250			0	3250	3250	1884	3	
3125				3125	3125	1809		
3000			0	3000	3000	2179	3	
2875				2875	2875	2085		
2750			0	2750	2750	1991	3	
2625				2625	2625	1898		
2500			0	2500	2500	1804	4	2500
2375				2375	2375	2295		2490
2250			0	2250	2250	2170	3	
2125				2125	2125	2045		
2000			2000	2000	1920			

Note:

For versions with real glass infill in the wicket door, the threshold height **SH₂** begins at LZ 4510 mm.

- On request
- Versions with glazing A3, M3, S3, U3, LB, P, XU on request
- Range change
- Range change with glazing A3, M3, S3, U3, LB, P, XU

- DHS** Clear passage height of wicket door
- DBS** Wicket door clear passage width
- DRH** Lever height
- LZ** Clear frame dimensions (from 1500)
- RM** Grid height
- SPB** Rail width

- SH₁** Threshold height (186)
- SH₂** Threshold height (311)
- n₁** Number of glazing frames
- Sn₁** Number of glazing frames in the wicket door
- TH** Door section height

Sectional door ALR F42 Glazing

Aluminium sectional door with extensive glazing, real glass

External view

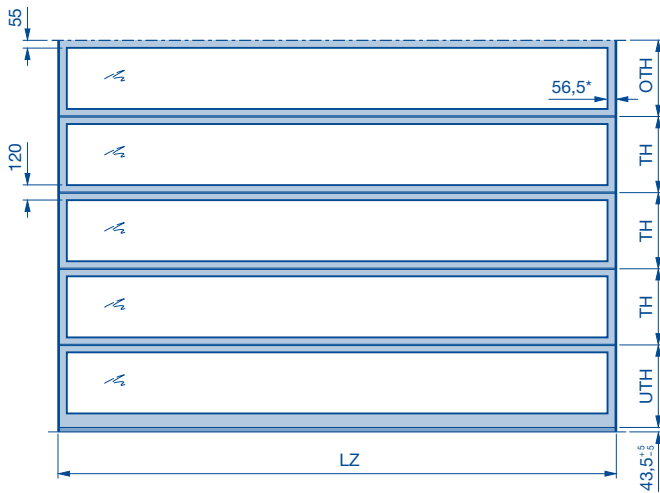

$$TH = \frac{\text{Door height} - 119}{\text{Number of glazing frames}}$$

$$UTH = TH + 84 \leq 785$$

$$OTH = TH + 35$$

* 76 with optional wide rail extrusions (91 mm)

Note:

- When using a shaft operator (installation example 5), the door locking is always opposite the operator side.

Size range

The validity tables with the size range shown are based on the standard door type version (see product description). In case of deviations, the valid size ranges in the product configurator must be taken into account. Any door width in 10 mm increments possible.

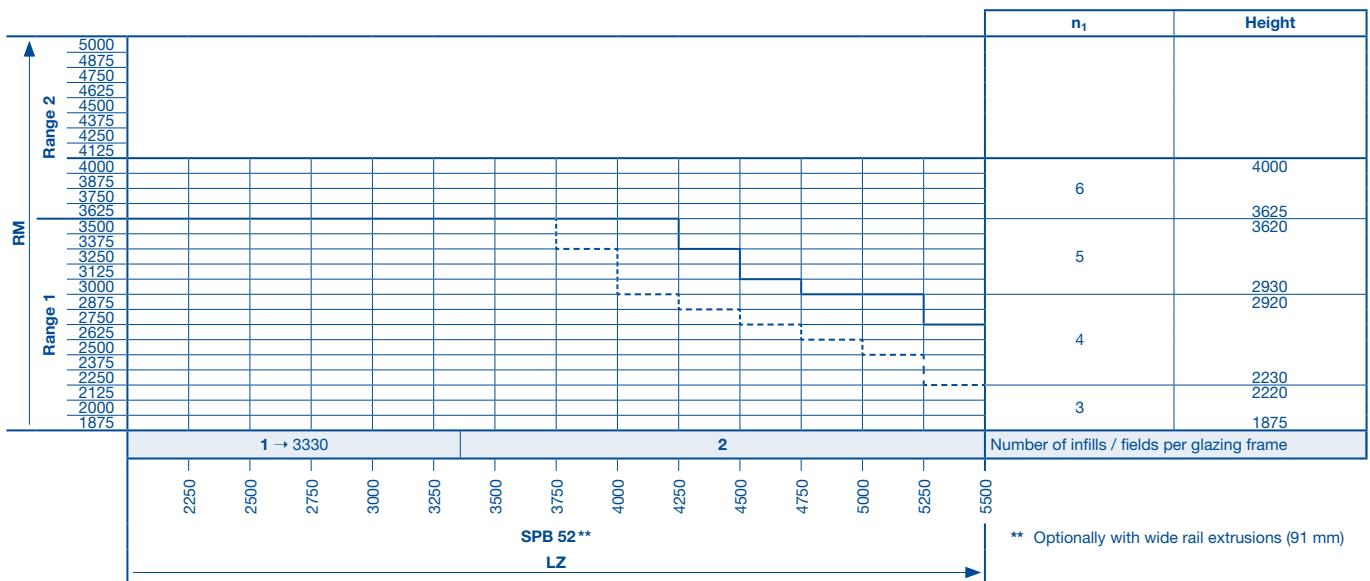

— Range change with VG glazing
 - - - Range change with E2 and G2 glazing
 RM Grid height
 LZ Clear frame dimensions (from 2000)

→ up to LZ
 SPB Rail width
 n₁ Number of glazing frames
 UTH Bottom door section height
 TH Door section height
 OTH Upper door section height

Sectional door ALR F42 Vitraplan

Aluminium sectional door with exclusive glazing

External view

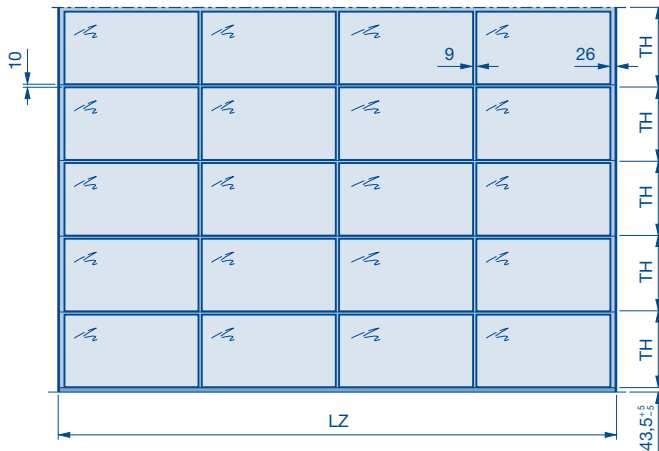

$$TH = \frac{\text{Door height} - 35}{\text{Number of glazing frames}}$$

Note:

- When using a shaft operator (installation example 5), the door locking is always opposite the operator side.
- For door widths from 5510 mm, diagonal struts are fitted into the bottom door section.

Size range

The validity tables with the size range shown are based on the standard door type version (see product description). In case of deviations, the valid size ranges in the product configurator must be taken into account. Any door width in 10 mm increments possible.

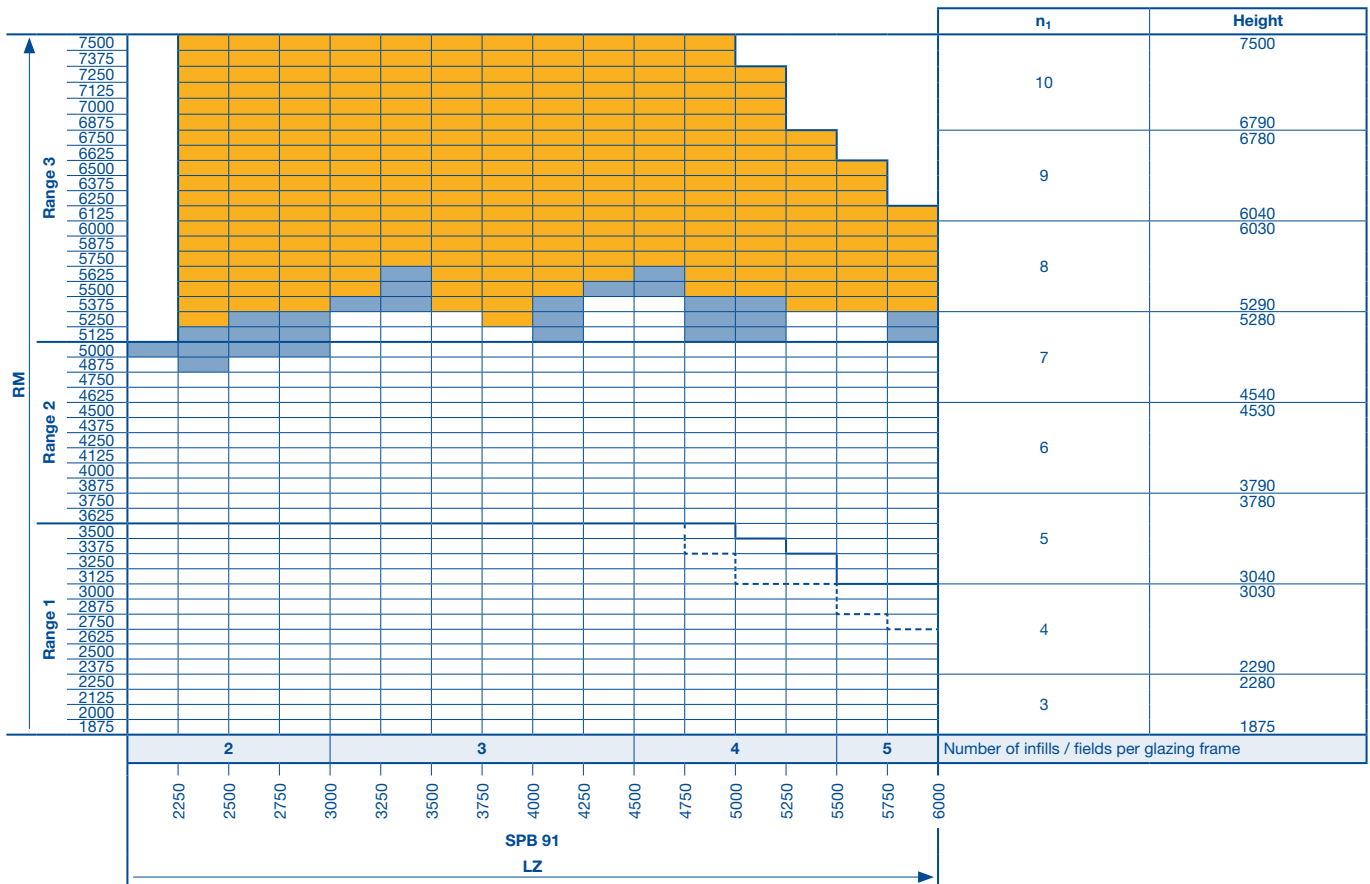

- On request
- Versions with glazing A3, S3, U3 on request
- Range change
- Range change with glazing A3, S3, U3

- RM** Grid height
- LZ** Clear frame dimensions (from 2000)
- SPB** Rail width
- n₁** Number of glazing frames
- TH** Door section height

Sectional door ALR F42 Vitraplan AT

Aluminium sectional door with exclusive facade panels

External view

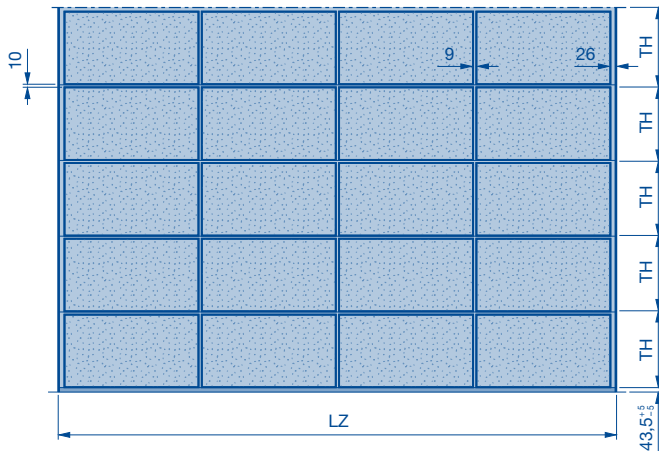

$$TH = \frac{\text{Door height} - 35}{\text{Number of glazing frames}}$$

Note:

- When using a shaft operator (installation example 5), the door locking is always opposite the operator side.
- For door widths from 5510 mm, diagonal struts are fitted into the bottom door section.

Size range

The validity tables with the size range shown are based on the standard door type version (see product description). In case of deviations, the valid size ranges in the product configurator must be taken into account. Any door width in 10 mm increments possible.

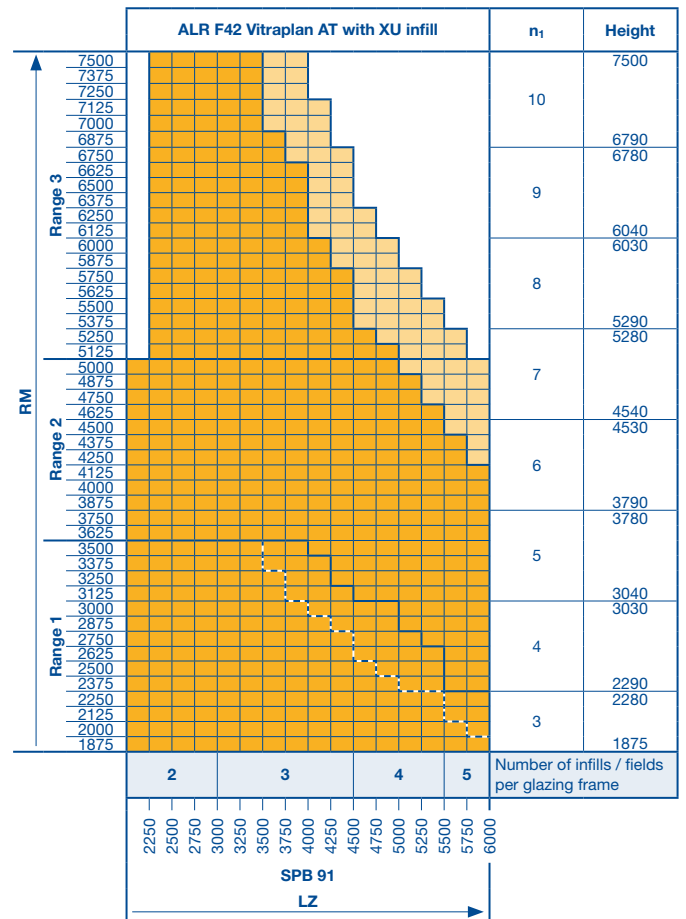
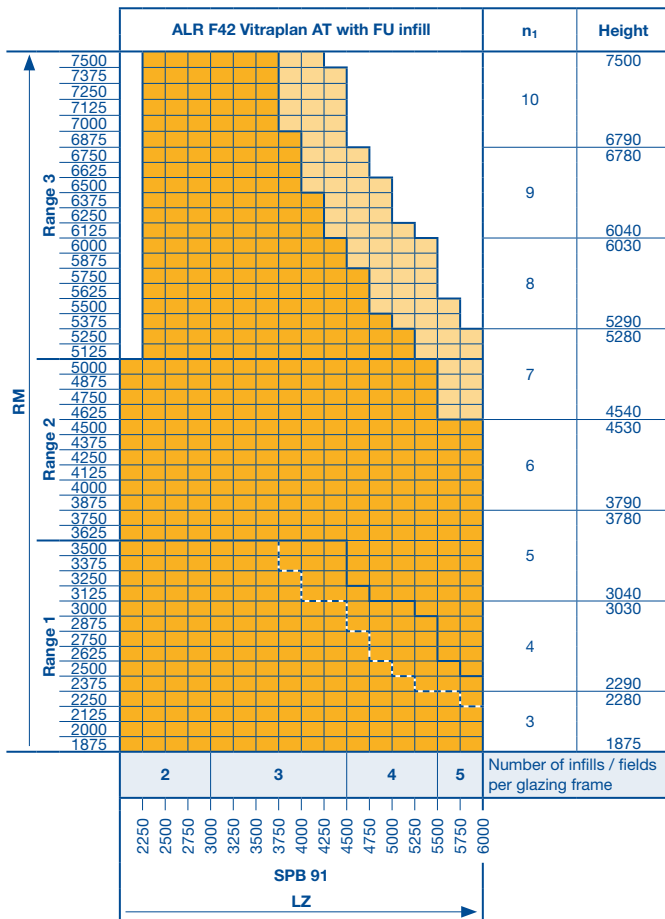

- On request
- Version with ALUCOBOND® on request
- Range change for version with ALUCOBOND®
- Range change for version with TRESPA®

- RM Grid height
- LZ Clear frame dimensions (from 2000)
- SPB Rail width
- n₁ Number of glazing frames

Glazing and wicket door arrangements

Sectional doors with 3 infills / fields

Glazing arrangements – external view

Sectional door SPU F42 with wicket door with trip-free threshold

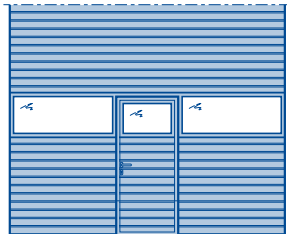

Sectional door SPU F42, matching the wicket door versions

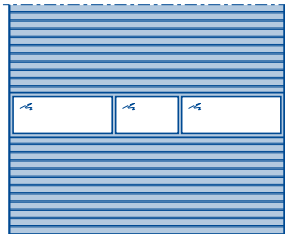

Sectional door SPU F42 with standard window division

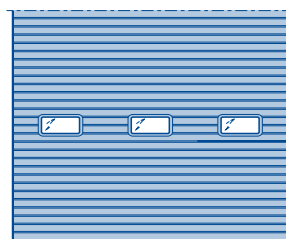
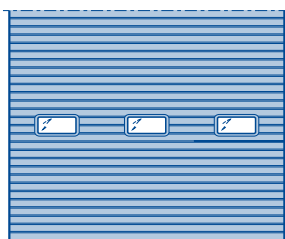
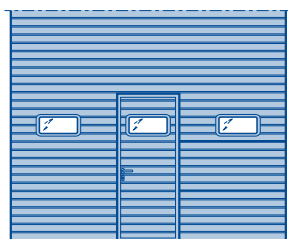
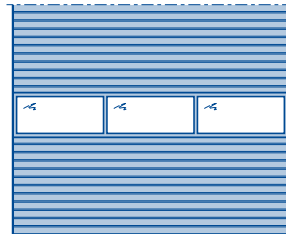

Sectional door APU F42 with wicket door with trip-free threshold

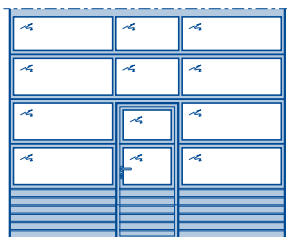

Sectional door APU F42, matching the wicket door versions

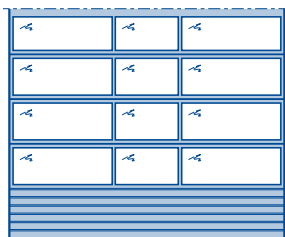

Sectional door APU F42 with standard window division

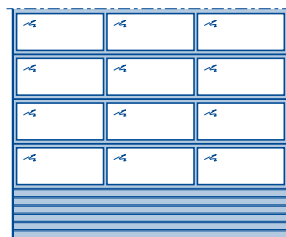

Sectional door ALR F42 with wicket door with trip-free threshold



Sectional door ALR F42, matching the wicket door versions

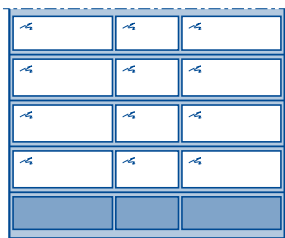

Sectional door ALR F42 with standard window division

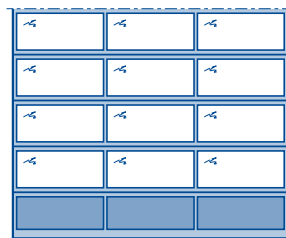

Arrangement of the wicket door

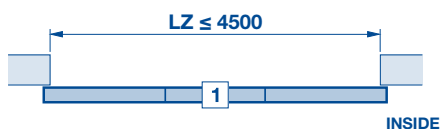

Notes:

- Wicket door clear passage width (DBS) = 940 mm.
- Wicket door only opening outwards.

Wicket door with short distance to outside door edge

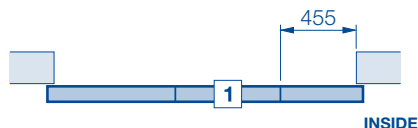

The short distance to the outside door edge is optionally possible on the left or right.

Note:

- Not possible for doors with real glass.

Glazing and wicket door arrangements

Sectional doors with 4 infills / fields

Glazing arrangements – external view

Sectional door SPU F42 with wicket door with trip-free threshold



Sectional door SPU F42, matching the wicket door versions

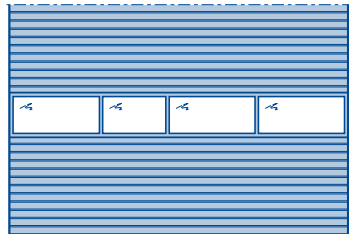

Sectional door SPU F42 with standard window division

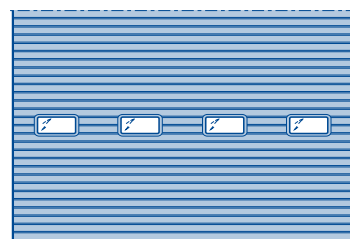
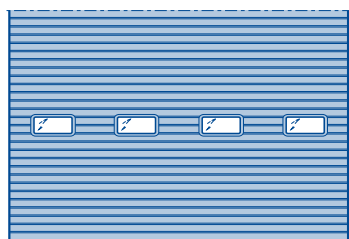
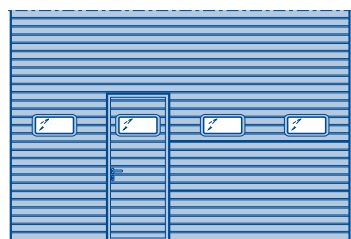
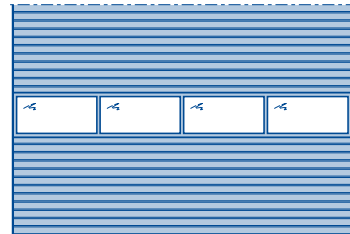

Sectional door APU F42 with wicket door with trip-free threshold

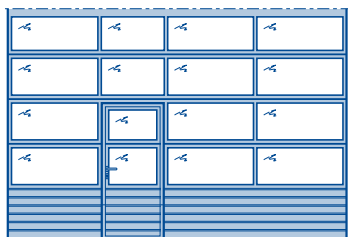

Sectional door APU F42, matching the wicket door versions

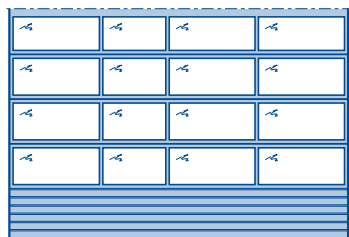

Sectional door APU F42 with standard window division

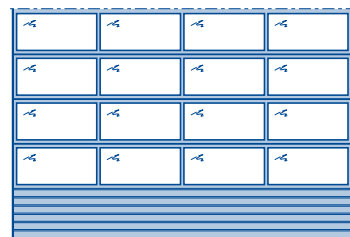

Sectional door ALR F42 with wicket door with trip-free threshold



Sectional door ALR F42, matching the wicket door versions



Sectional door ALR F42 with standard window division

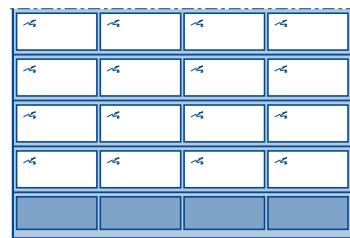

Arrangement of the wicket door

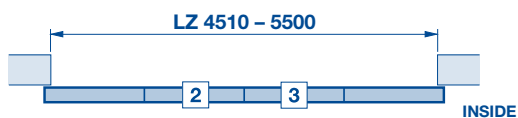

Notes:

- Wicket door clear passage width (DBS) = 940 mm.
- Wicket door only opening outwards.

Wicket door with short distance to outside door edge

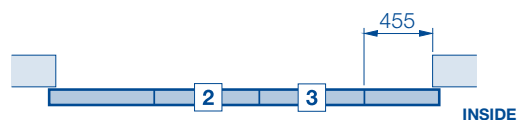

The short distance to the outside door edge is optionally possible on the left or right.

Note:

- Not possible for doors with real glass.

Glazing and wicket door arrangements

Sectional doors with 5 infills / fields

Glazing arrangements – external view

Sectional door SPU F42 with wicket door with trip-free threshold



Sectional door SPU F42, matching the wicket door versions

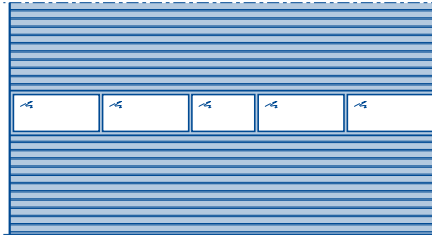

Sectional door SPU F42 with standard window division

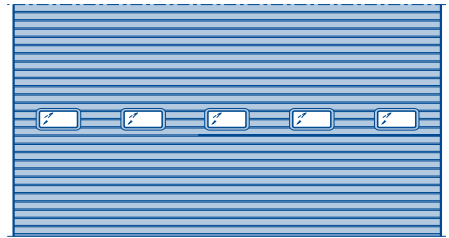
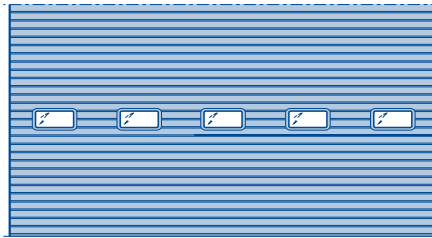
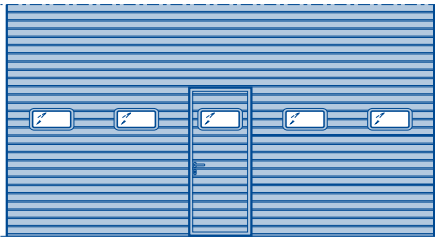
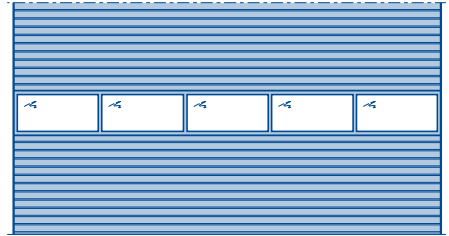

Sectional door APU F42 with wicket door with trip-free threshold

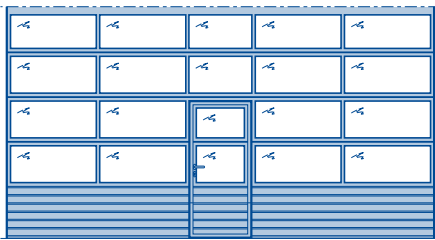

Sectional door APU F42, matching the wicket door versions

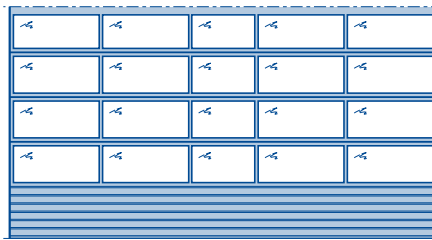

Sectional door APU F42 with standard window division

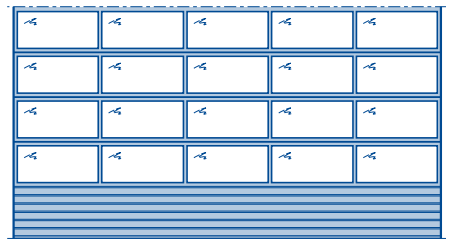

Sectional door ALR F42 with wicket door with trip-free threshold



Sectional door ALR F42, matching the wicket door versions

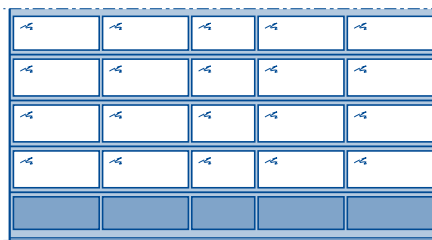

Sectional door ALR F42 with standard window division

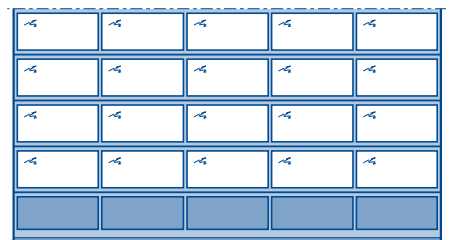

Arrangement of the wicket door

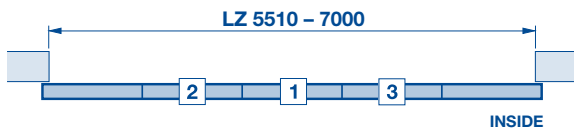

Notes:

- Wicket door clear passage width (DBS) = 940 mm.
- Wicket door only opening outwards.

Wicket door with short distance to outside door edge

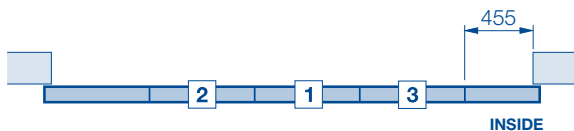

The short distance to the outside door edge is optionally possible on the left or right.

Note:

- Not possible for doors with real glass.

Infills / fields and glazing

Series 40

Number of infills / fields per glazing frame

Sectional door without wicket door	
Glazing frame type N	1 2 3 4 5 6 7 8
Glazing frame type B	1 2 → 3330 3 4 → 6670 5
Sectional door with wicket door	
Glazing frame type N	X 3 → 1750-3500 4 5 6 7 X
	1200 1500 2000 2250 2500 2750 3000 3250 3500 3750 4000 4250 4500 4750 5000 5250 5500 5750 6000 6250 6500 6750 7000 7250 7500 7750 8000
	LZ

Number of compound glazings per door section

Sectional door without wicket door	
Standard type A	1 → 1680 2 3 4 5 6 7 8
Standard type D	1 → 1640 2 3 4 5 6 7 8
Standard type E	1 → 1860 2 → 2750 3 → 3650 4 → 4540 5 → 5510 6 X
Sectional door with wicket door	
Type A or type D	X 1 → 1750-2650 3 4 5 6 7 X
Type E	X 1 → 1840-2920 3 → 3880 4 → 4830 5 → 5780 6 X
	1200 1500 2000 2250 2500 2750 3000 3250 3500 3750 4000 4250 4500 4750 5000 5250 5500 5750 6000 6250 6500 6750 7000 7250 7500 7750 8000
	LZ

LZ Clear frame dimension
→ up to LZ

Wind load class

Resistance to wind load

Detailed technical data can be found in the product configurator.

	Wind classes acc. to EN 12424	
SPU F42, APU F42, ALR F42	4	3
APU F42 Thermo, ALR F42 Thermo	4	3
ALR F42 Glazing, ALR F42 Vitraplan	3	

LZ

Wind load class for sectional doors with wicket door

	Wind classes acc. to EN 12424	
SPU F42, APU F42, ALR F42	3	2
APU F42 Thermo, ALR F42 Thermo	3	2

LZ

Increased wind load class only for sectional doors without wicket door

	Wind classes acc. to EN 12424		Set 1	Set 2	Set 3	
SPU F42, APU F42, ALR F42	4	4	4	4	4	3
APU F42 Thermo, ALR F42 Thermo	4	4	4	4	4	

LZ

Please note:

- A technical inspection is required for an increased wind load class with special requirements!
- Additional information in the table on page 6, technical manual depth 42 mm.
- Not possible for ALR F42 Glazing and ALR F42 Vitraplan.

- Set 1** Door leaf reinforcement 85, reinforced hardware
- Set 2** Door leaf reinforcement 85, reinforced hardware, twin roller
- Set 3** Door leaf reinforcement 100, reinforced hardware, twin roller

LZ Clear frame dimension
→ up to LZ

Side door NT 60 and NT 80 Thermo

Possible handing options

fitting in the opening

Fitting next to the garage door, opening inwards or outwards, RH or LH hinged

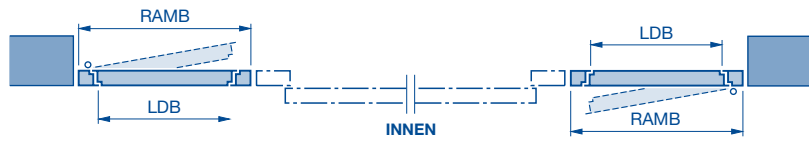

Fitting in the opening, opening inwards or outwards, RH or LH hinged



Fitting behind the opening

Only opening inwards, RH or LH hinged

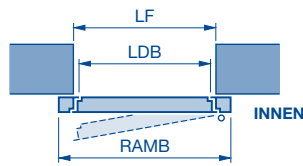

Structural opening	Ordering size Overall frame dimensions RAMB x RAMH
875 x 2000	855 x 1990
875 x 2125	855 x 2115
1000 x 2000	980 x 1990
1000 x 2125	980 x 2115

Size range: width: RAMB 770 to 1300, height: RAMH 1865 to 2525 (**indicate overall frame dimensions**)

Doors with multiple-point locking: RAMH = ≥ 1920 mm

Clear passage dimensions:

	Opening angle	Width	Height
NT 60	136°	RAMB - 149	RAMH - 70
	90°	RAMB - 194	
NT 80 Thermo	136°	RAMB - 164	RAMH - 70
	90°	RAMB - 215	

Note:

Side door version in ALR F42 Vitraplan with aluminium fascia profile opening inwards on request!

LF Structural opening
RAMB Overall frame width
RAMH Overall frame height
LDB Clear passage width

LDH Clear passage height
LZ Clear frame dimension

Side door NT 60

With S-ribbed, Stucco-textured / L-ribbed, Micrograin infills



Note:
Compound window with RC2 version not possible.

* See page 42
LF Structural opening
RAMB Overall frame width
RAMH Overall frame height

BH Panel height
BB Panel width
LDB* Clear passage width
LDH Clear passage height

TH Door section height
SO Bottom section height
LZ Clear frame dimension
n₁ Number of door sections / glazing frames

Side door NT 60

With L-ribbed, Micrograin infills

Compound glazing type A TH = 500

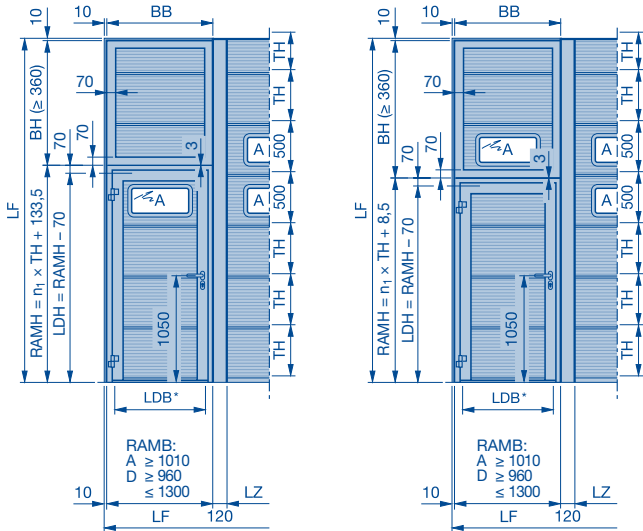

Compound window type A TH = 625 and 750

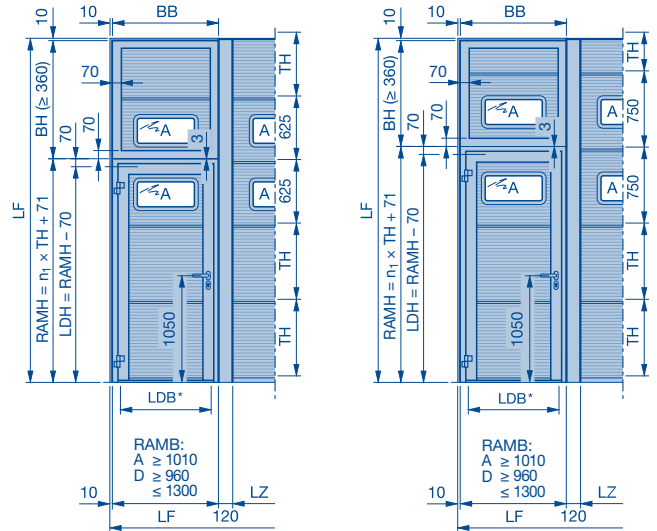

Compound window type A TH = 625 / 750 and 750 / 625

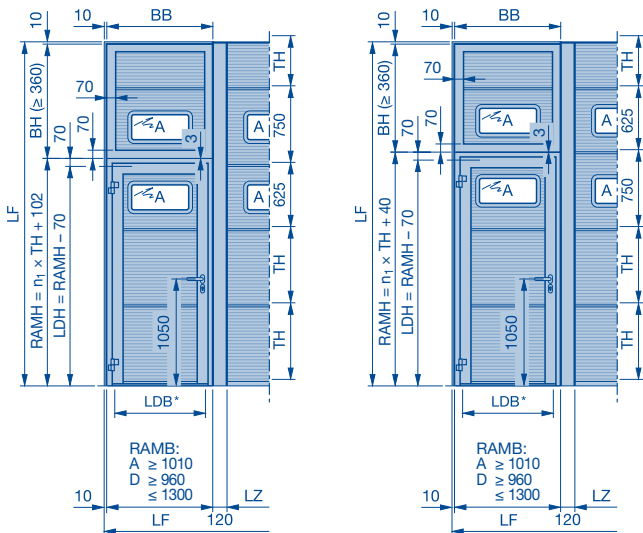

Compound window type E TH = 625

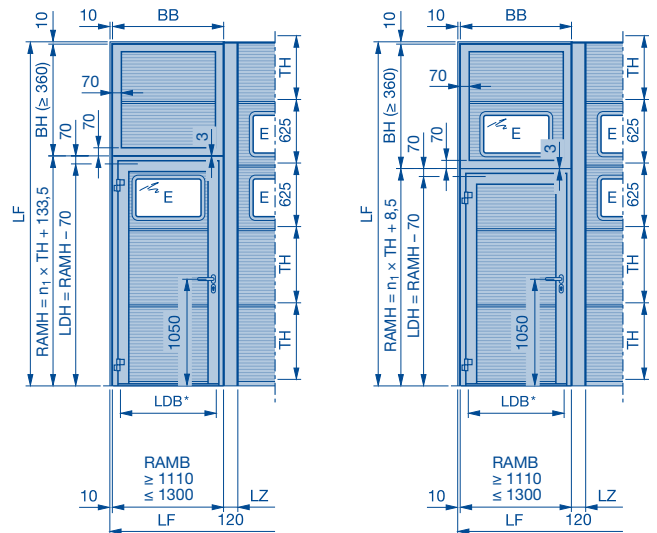

Compound window type E TH = 750

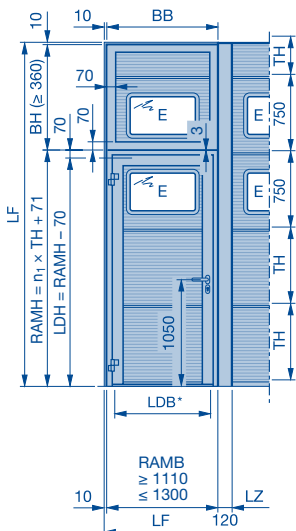

Note:
Compound window with RC2 version not possible.

(Legend see page 43)

Side door NT 60

With S-ribbed, Stucco-textured / L-ribbed, Micrograin infills

Side door NT 60 matching door type APU F42

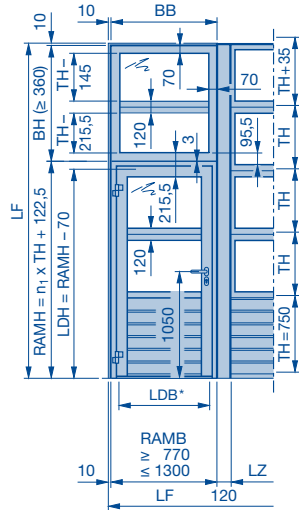

Side door NT 60 matching door type ALR F42

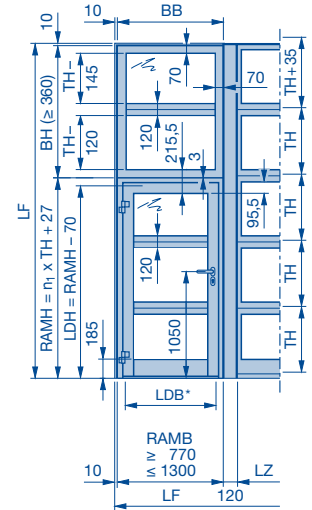
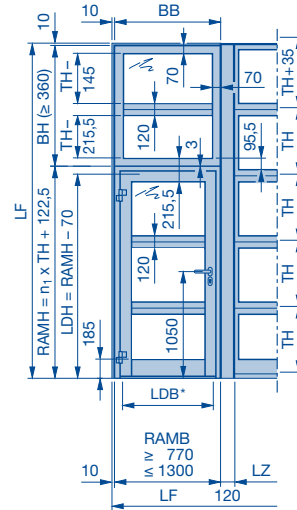
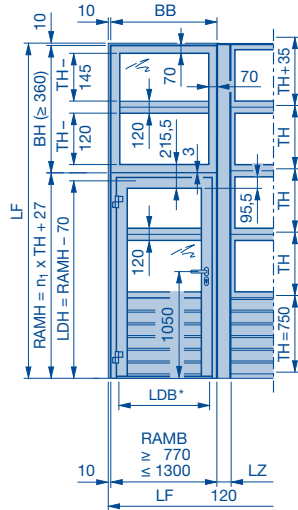

Side door NT Vitraplan

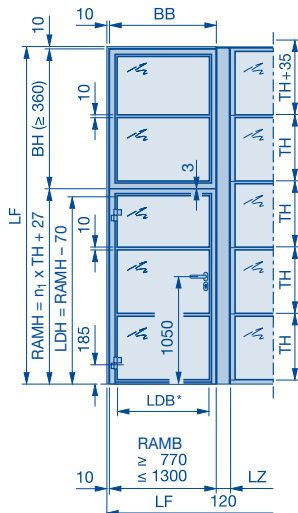
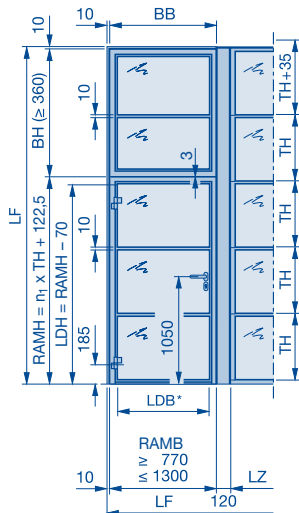

Side door NT Vitraplan AT

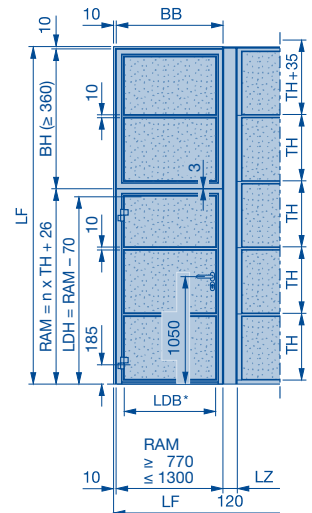
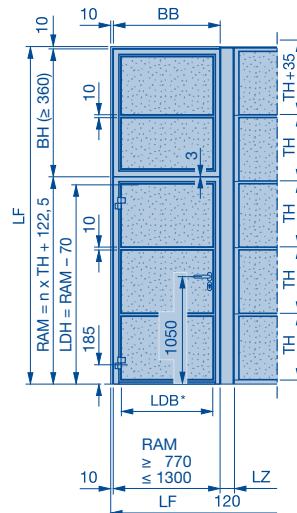

Note:

Side door NT Vitraplan not possible in RC2 version.

* See page 42
LF Structural opening
RAMB Overall frame width
RAMH Overall frame height

BH Panel height
BB Panel width
LDB Clear passage width
LDH Clear passage height

TH Door section height
SO Bottom section height
LZ Clear frame dimension
n₁ Number of door sections / glazing frames

Side door NT 60

Possible fitting options

Possible fitting options

SPU in the opening

No window section, no compound glazing

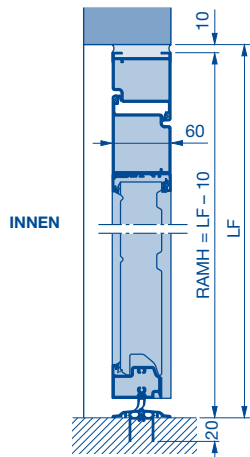

SPU behind the opening

No window section, no compound glazing

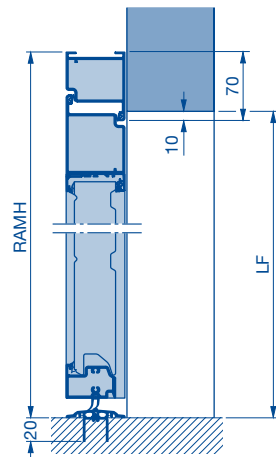

SPU with fascia panel in the opening

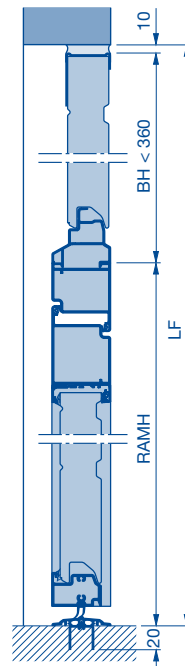

SPU, APU with fascia panel in the opening

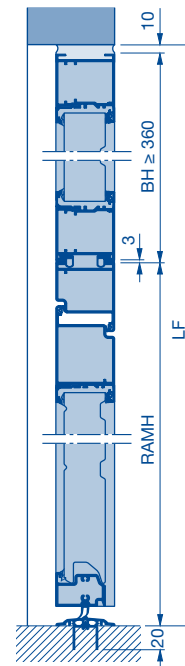

ALR with fascia panel in the opening

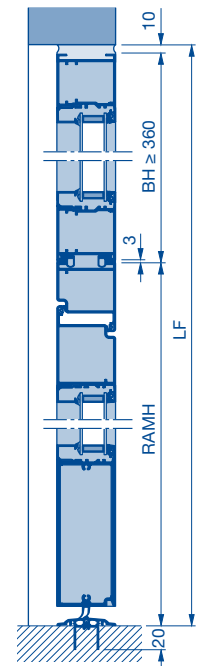

In the opening

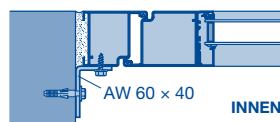

Plugs for metal frame

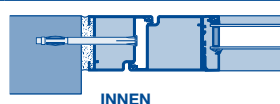

Tapping screw with countersunk head B 6.3 x 80

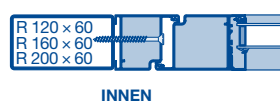

(Bottom illustration with 50 mm* extension profile for all-over insulation)
* Optionally with 25 mm

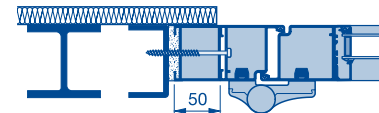

Behind the opening

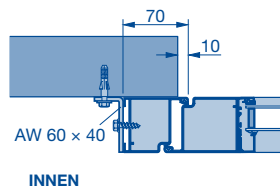

Side door NT 60 flush with sectional door

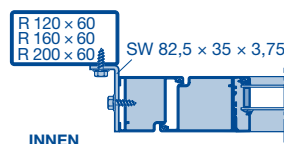

R Box section
AW Aluminium angle
SW Steel angle

BH Panel height
RAMH Overall frame height
LDB Clear passage width

LF Structural opening

Side door NT 60 RC2

Possible fitting options

Possible fitting options

Note:

The side door and panel must be fitted in accordance with DIN EN 1627. Side door NT Vitraplan not possible in RC2 version.

SPU in the opening

No window section, no compound glazing

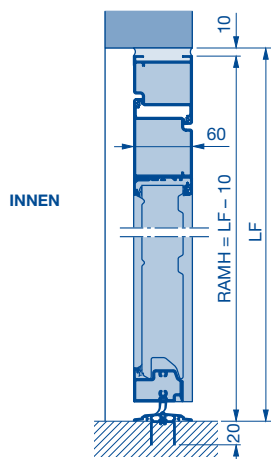

SPU behind the opening

No window section, no compound glazing

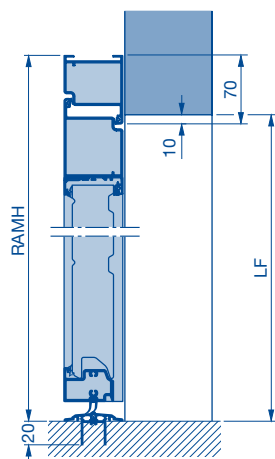

SPU, APU with fascia panel in the opening

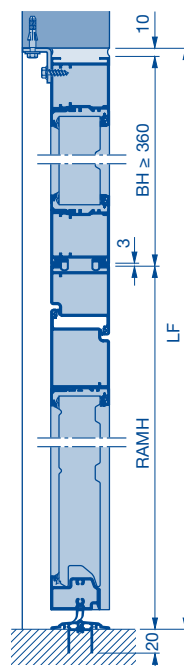

ALR with fascia panel in the opening

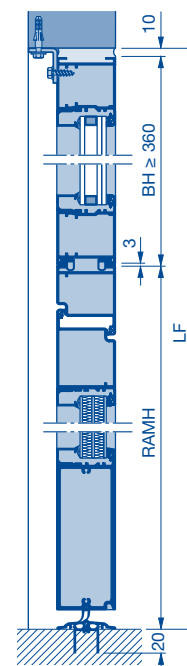

In the opening

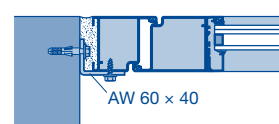
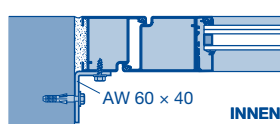

Plugs for metal frame

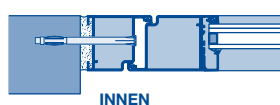

Tapping screw with countersunk head
B 6.3 x 80

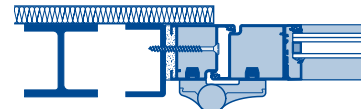
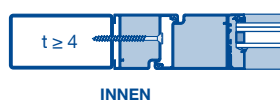

Note:

Only use plugs for metal frame and tapping screw with countersunk head when fitting the side door.

Behind the opening

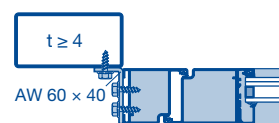
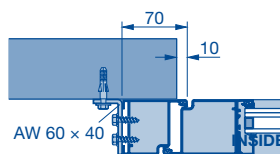

Side door NT 60 flush with sectional door

AW Aluminium angle
t Fastening thickness
BH Panel height

RAMH Overall frame height
LDB Clear passage width
LF Structural opening

Side door NT 80 Thermo

With S-ribbed, Stucco-textured / L-ribbed, Micrograin infills



Note:
Compound window with RC2 version not possible.

* See page 42
LF Structural opening
RAMB Overall frame width
RAMH Overall frame height

BH Panel height
BB Panel width
LDB* Clear passage width
LDH Clear passage height

TH Door section height
SO Bottom section height
LZ Clear frame dimension
n₁ Number of door sections / glazing frames

Side door NT 80 Thermo

With L-ribbed, Micrograin infills

Compound glazing type A TH = 500

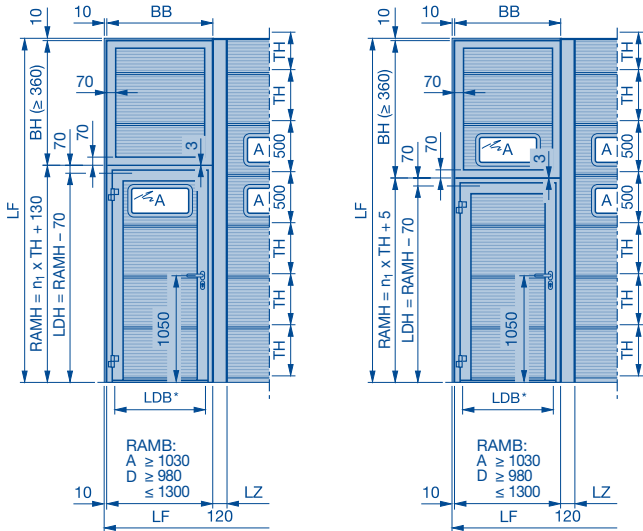

Compound window type A TH = 625 and 750

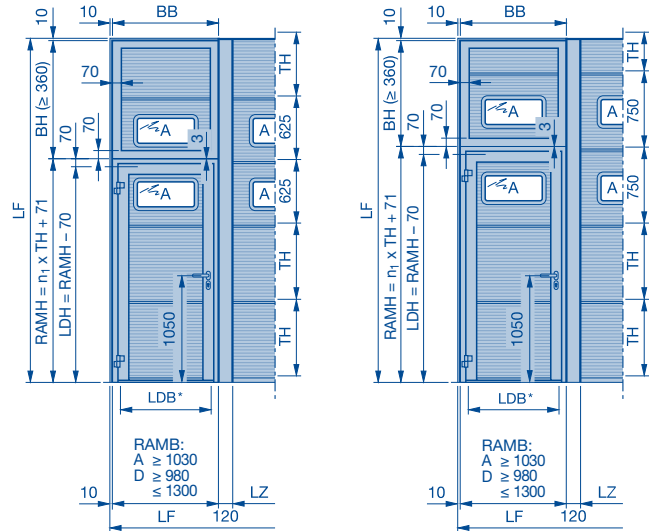

Compound window type A TH = 625 / 750 and 750 / 625

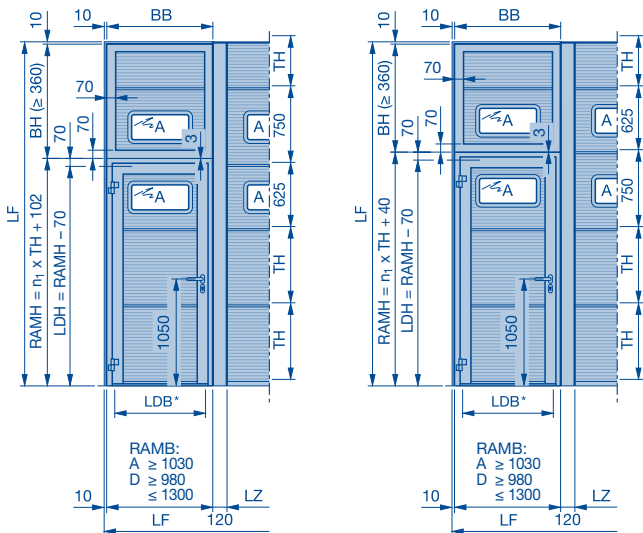

Compound window type E TH = 625

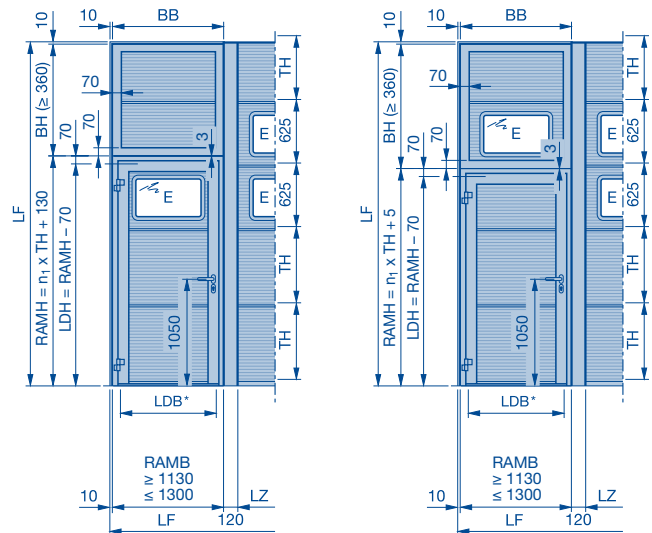

Compound window type E TH = 750

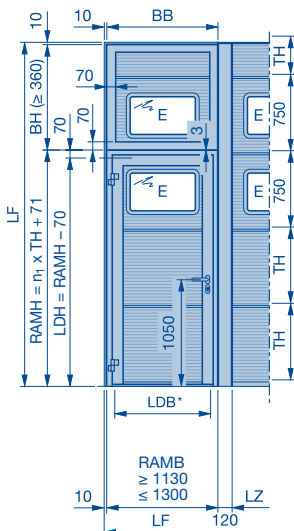

Note:
Compound window with RC2 version not possible.

(Legend see page 48)

Side door NT 80 Thermo

Possible fitting options

Possible fitting options

SPU in the opening

No window section, no compound glazing

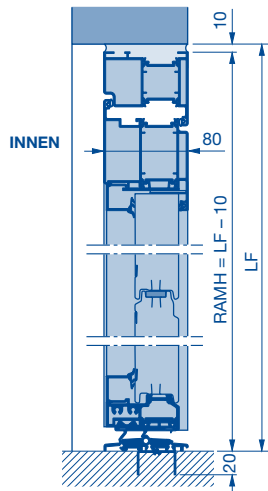

SPU behind the opening

No window section, no compound glazing

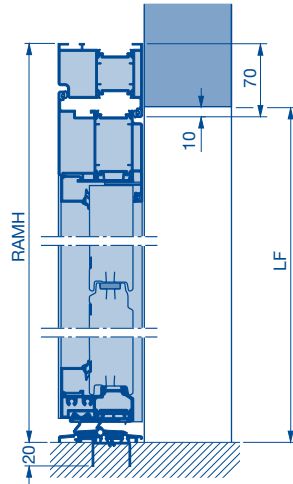

SPU, APU with fascia panel

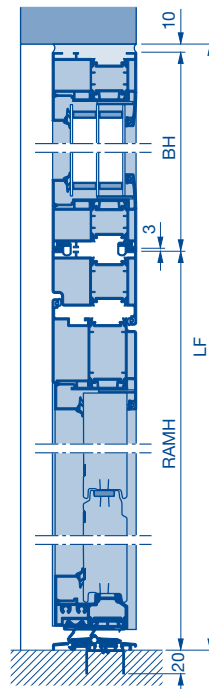

ALR with fascia panel

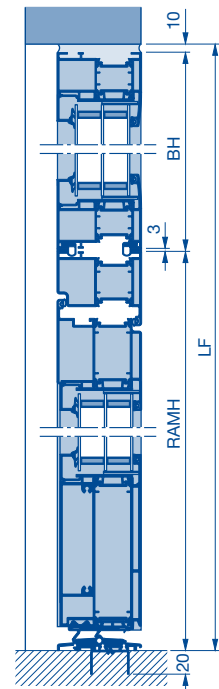

In the opening

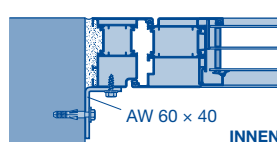

Plugs for metal frame

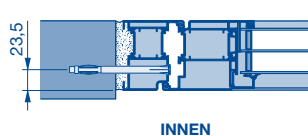

(Bottom illustration with 50 mm* extension profile for all-over insulation)

* Optionally with 25 mm

Tapping screw with countersunk head B 6.3 x 80

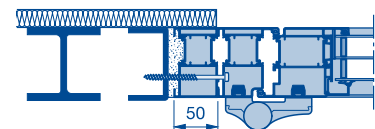
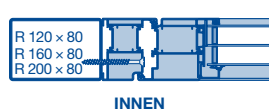

Behind the opening

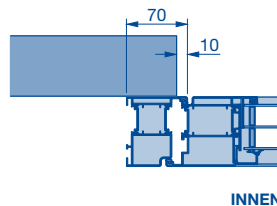

Note:

Fitting with thermal break requires on-site preparations.

R Box section
AW Aluminium angle
SW Steel angle

BH Panel height
RAMH Overall frame height
LDB Clear passage width

LF Structural opening

Side door NT 80 Thermo RC2

Possible fitting options

Possible fitting options

Note:

The side door and panel must be fitted in accordance with DIN EN 1627.

SPU in the opening

No window section, no compound glazing

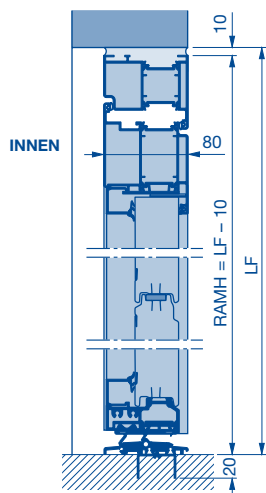

SPU behind the opening

No window section, no compound glazing

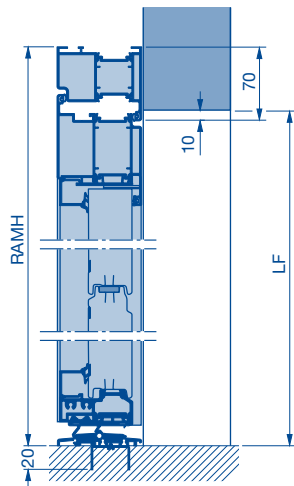

SPU, APU with fascia panel

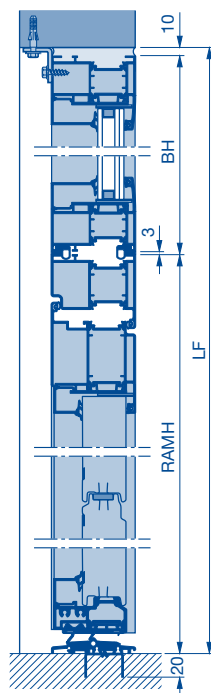

ALR with fascia panel

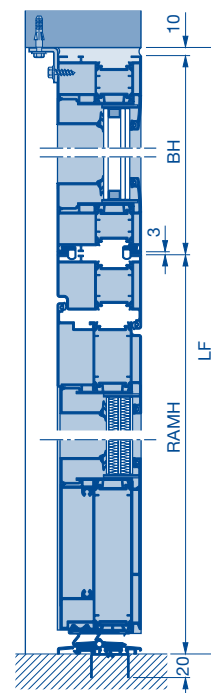

In the opening

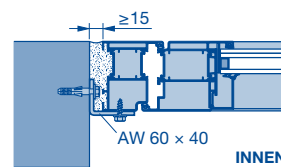
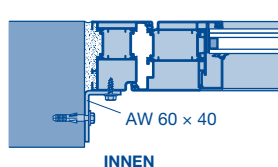

Plugs for metal frame

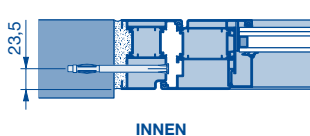

Tapping screw with countersunk head
B 6.3 x 80

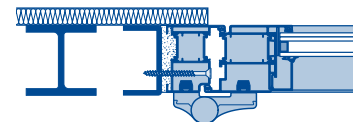
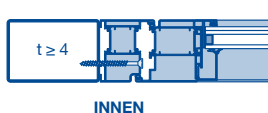

Note:

Only use plugs for metal frame and tapping screw with countersunk head when fitting the side door.

Behind the opening

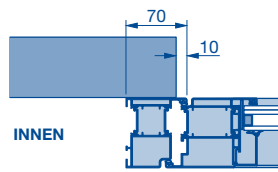

Note:

Fitting with thermal break requires on-site preparations.

R Box section
AW Aluminium angle
SW Steel angle

BH Panel height
RAMH Overall frame height
LDB Clear passage width

LF Structural opening

Fixed elements

Possible fitting options and fitting examples

Possible fitting options

SPU F42 behind the opening

No window section, no compound glazing

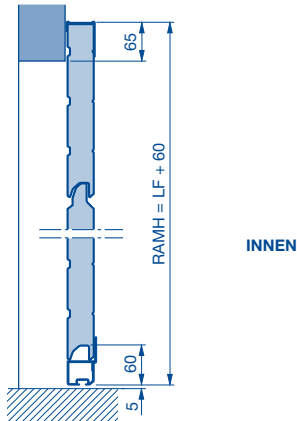

APU F42 behind the opening

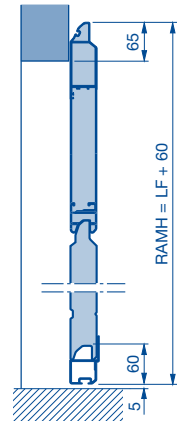

ALR F42, ALR F42 Thermo behind the opening

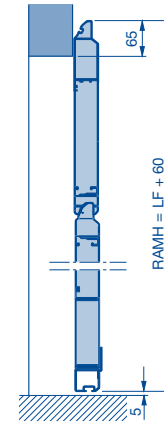

SPU F42 in the opening

No window section, no compound glazing

INNEN

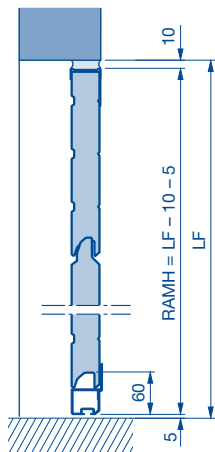

APU F42 in the opening

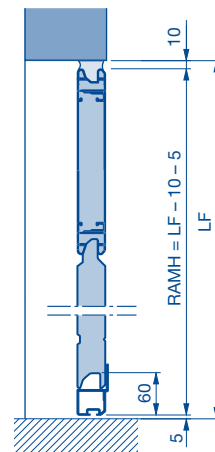

ALR F42, ALR F42 Thermo in the opening

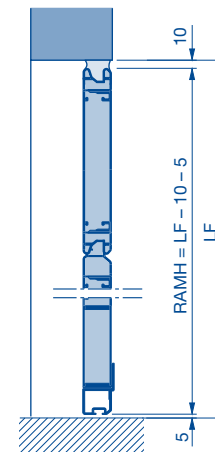

Fitting examples

Behind the opening

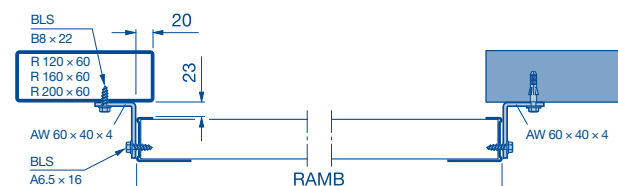
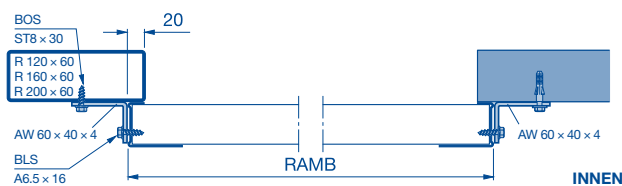

In the opening

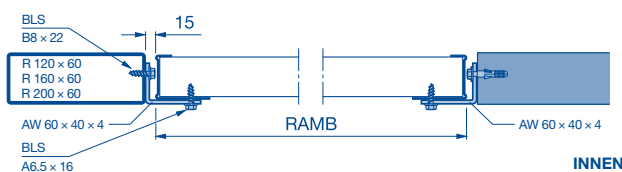

In front of the opening

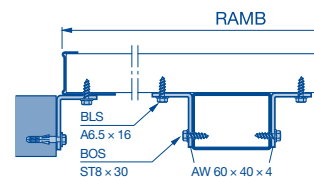

Side door

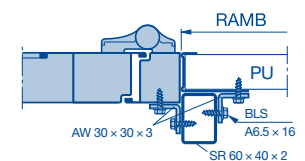

AW Aluminium angle
SR Support tube
AR Glazing frame

PU PU section
LF Structural opening
RAMB Overall frame width

RAMH Overall frame height
BOS drilling screw
BLS Self-tapping screw

Clear passage

Series 60

Track applications N / NA / ND / NS / NK

	without operator and without chain hoist	Chain hoist or WA 500 / 500 FU	WA 300	ITO / SupraMatic**
LZ ≤ 5500				
Without wicket door	RM - 100	RM	RM - 30	RM
Wicket door with threshold	RM - 120	RM - 20	RM - 50	RM - 20
Wicket door without threshold	RM - 165	RM - 65	RM - 95	RM - 65
LZ > 5500				
Without wicket door	RM - 150	RM - 50	RM - 80	RM - 50
Wicket door with threshold	RM - 170	RM - 70	RM - 100	RM - 70
Wicket door without threshold ***	RM - 185	RM - 135	RM - 165	RM - 135

Track application L with swivel mechanism

	without operator and without chain hoist	Chain hoist or WA 500 / 500 FU	WA 300	ITO / SupraMatic
LZ ≤ 5500				
Without wicket door *	-	RM	RM - 30	-
Wicket door with threshold	-	RM - 50	RM - 80	-
Wicket door without threshold	-	RM - 65	RM - 95	-
LZ > 5500				
Without wicket door	-	RM - 50	RM - 80	-
Wicket door with threshold	-	RM - 100	RM - 130	-
Wicket door without threshold	-	RM - 135	RM - 165	-

Note:

For wicket door arrangement 2 and 4 (LH hinged) or 3 and 5 (RH hinged) with opposite operator side, the clear passage can be found in the product configurator!

Track application L without swivel mechanism

	without operator and without chain hoist	Chain hoist or WA 500 / 500 FU	WA 300	ITO / SupraMatic
LZ ≤ 5500				
Without wicket door	RM - 325	RM - 110	RM - 140	RM
Wicket door with threshold	RM - 375	RM - 130	RM - 160	RM - 50
Wicket door without threshold	RM - 440	RM - 170	RM - 220	RM - 85
LZ > 5500				
Without wicket door	RM - 375	RM - 160	RM - 190	RM - 50
Wicket door with threshold	RM - 375	RM - 180	RM - 210	RM - 100
Wicket door without threshold ***	RM - 475	RM - 240	RM - 270	RM - 165

* For ALR F42 / ALR F42 Thermo with real glass infill VG, E2 and G2 and ALR F42 Vitraplan LZ > 3000; ALR F42 Glazing LZ > 3330 and ALR F42 / ALR F42 Thermo LZ > 5000, the calculation applies to a wicket door with threshold.

** Track applications NS and NK not possible.

*** For versions with real glass infill LZ > 4500

- Not possible
a° Inclination

HKZ Chain hoist
LZ Clear frame dimension

RM Grid height

Clear passage

Series 60

Track application LD with swivel mechanism

a°	without operator and without chain hoist	Chain hoist or WA 500 / 500 FU		WA 300		ITO/ SupraMatic
		<6°	6° – 10°	<6°	6° – 10°	
LZ ≤ 5500						
Without wicket door	–	RM		RM - 30		–
Wicket door with threshold	–	RM - 50	RM - 30	RM - 80	RM - 60	–
Wicket door without threshold	–	RM - 65		RM - 95		–
LZ > 5500						
Without wicket door	–	RM - 50		RM - 80		–
Wicket door with threshold	–	RM - 100	RM - 80	RM - 130	RM - 110	–
Wicket door without threshold	–	RM - 135		RM - 195		–

Note:

For wicket door arrangement 2 and 4 (LH hinged) or 3 and 5 (RH hinged) with opposite operator side, the clear passage can be found in the product configurator!

Track application LD without swivel mechanism

a°	without operator and without chain hoist	Chain hoist or WA 500 / 500 FU		WA 300		ITO/ SupraMatic
		2° – 16°	18° – 30°	2° – 16°	18° – 30°	
LZ ≤ 5500						
Without wicket door	RM - 325	RM - 110 + (a° × 2,5)	RM - 115 + (a° × 2,5)	RM - 140 + (a° × 2,5)	RM - 145 + (a° × 2,5)	RM
Wicket door with threshold	RM - 375	RM - 135 + (a° × 3,2)	RM - 150 + (a° × 3,75)	RM - 165 + (a° × 3,2)	RM - 180 + (a° × 3,75)	RM - 50
Wicket door without threshold	RM - 440	RM - 175 + (a° × 3,2)	RM - 190 + (a° × 3,75)	RM - 225 + (a° × 3,2)	RM - 240 + (a° × 3,75)	RM - 85
LZ > 5500						
Without wicket door	RM - 375	RM - 160 + (a° × 2,5)	RM - 165 + (a° × 2,5)	RM - 190 + (a° × 2,5)	RM - 195 + (a° × 2,5)	RM - 50
Wicket door with threshold	RM - 375	RM - 180 + (a° × 3,2)	RM - 200 + (a° × 3,75)	RM - 210 + (a° × 3,2)	RM - 230 + (a° × 3,75)	RM - 100
Wicket door without threshold ***	RM - 475	RM - 240 + (a° × 3,2)	RM - 260 + (a° × 3,75)	RM - 270 + (a° × 3,2)	RM - 290 + (a° × 3,75)	RM - 165

*** For versions with real glass infill LZ > 4500

– Not possible
a° Inclination

HKZ Chain hoist
LZ Clear frame dimension

RM Grid height

Track application: N

Normal track application

Detailed technical data can be found in the product configurator.

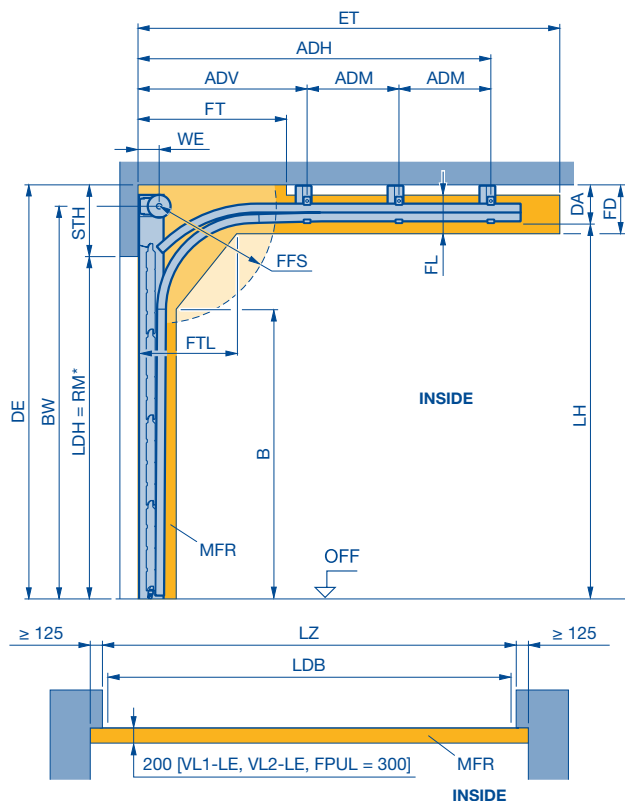

ADH	Distance to rear ceiling anchor	FTL	Clearance door section in the double radius
ADM	Distance to central ceiling anchor	LDB	Clear passage width with ThermoFrame (see page 82)
ADV	Distance to ceiling anchor, front	LDH	Clear passage height
B	Start of double radius	LH	Track height
BW	Position of shaft support	LZ	Clear frame dimension
DA	Min. distance to ceiling	MFR	Space for fitting the door
DAL	Anchor length	OFF	Finished floor level (FFL)
DE	Min. ceiling height	RM	Grid height
ET	Min. distance back	STH	Min. headroom
FD	Min. ceiling clearance	WE	Shaft centre from lintel
FFS	Spring tensioning clearance		
FL	Track clearance		
FPUL	Spring buffers below the track		
FT	Clearance for door operation		

Door weights for roof loads:

SPU F42 / APU F42 Thermo / ALR F42 Thermo	= 320 N/m ²
APU F42 / ALR F42	= 280 N/m ²
ALR F42 Glazing / ALR F42 Vitraplan / ALR F42 Vitraplan AT	= 560 N/m ²

Observe min. sideroom, see page 82.

	STH	WE	DA	BW	FT
N 1	390	140	183	RM + 310	1250
N 2	440	160	233	RM + 335	
N 3	550	180	343	RM + 415	
With double spring shaft	760		543	RM + 415	

B	DE	FFS	FD	FL	FTL	LH
RM - 310	STH + RM	min 90° (745)	DA + 65	230	670	RM + 207

ET***		
N 1 / N 2	RM + 395	Manual operation with short spring buffer
	RM + 665	Shaft operator with long spring buffer
N 3	RM + 665	For manual operation and shaft operator with long spring buffer

*** Simplified calculation

Notes:

- Observe the permissible size ranges of the door types on pages 10–15 and 18–35 under all circumstances!
- The clearance required for fitting the door must be free of supply lines, heater fans, etc.
- If using the spring buffer below the track, the clear height under the track in the area of the spring buffer is reduced by 70 mm.
- For version with wicket door, manually operated: chain hoist recommended!

* Note:

Observe clear passage height LDH, see page 54.

Min. headroom

Track size	Headroom	Track size	Headroom	Track size	Headroom
N 1, NS 1, NK 1	390	GS 1, GK 1	567	V 6	RM + 540
N 2, NS 2, NK 2	440	GS 1, GK 2	617	V 7	RM + 580
N 3	550	L 1, LD 1, L 2, LD 2	200	V 9	RM + 675
NA 1	400	H 4, HD 4	780	VA 6	RM + 550
NA 2	450	H 5, HD 5	840	VS 6, VS 7	**
ND 1	410	H 8, HD 8	880	VS 9	**
ND 2	440	HA 4	790	VU 6	RM + 310
ND 3	550	HU 4, HU 5, HU 8, RD 4, RD 5, RD 8	1750	VU 7	RM + 310
ND 6	490	HS 4, HK 4	808	VU 9	RM + 310
ND 7	510	HS 5, HK 5	835	WS 6, WS 7, WS 9	**
NH 1, GD 1	569	HS 8, HK 8	875	HP 4	1930
NH 2, GD 2	634	RS 4, RK 4, RS 5, RK 5	1477	HP 5	1960
NH 3	709				Dimensions in mm

** Dimensions can be found in the product configurator.

Track application: NA

Normal track application

With high-mounted torsion spring shaft

Detailed technical data can be found in the product configurator.

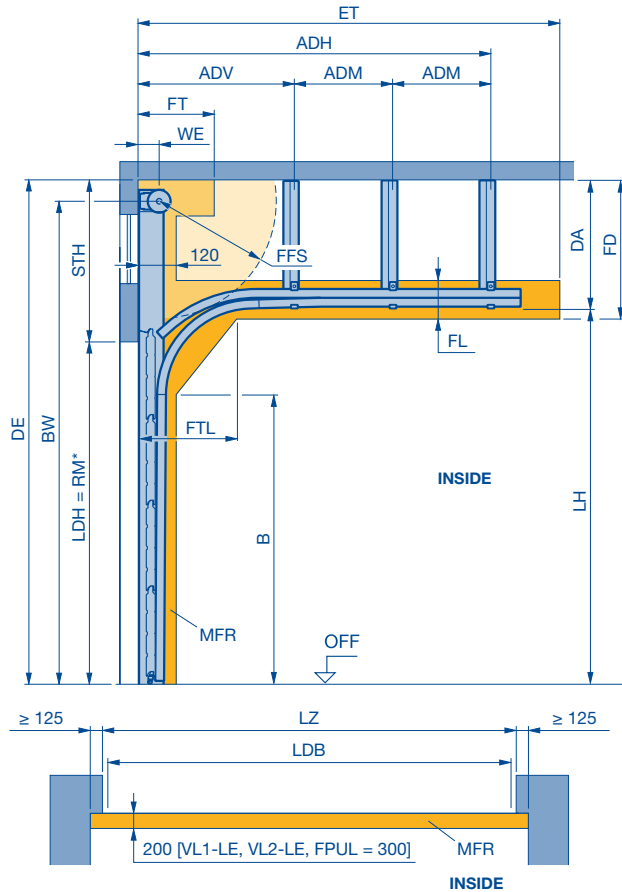

ADH	Distance to rear ceiling anchor	FTL	Clearance door section in the double radius
ADM	Distance to central ceiling anchor	LDB	Clear passage width with ThermoFrame (see page 82)
ADV	Distance to ceiling anchor, front	LDH	Clear passage height
B	Start of double radius	LH	Track height
BW	Position of shaft support	LZ	Clear frame dimension
DA	Min. distance to ceiling (depends on order)	MFR	Space for fitting the door
DE	Ceiling height (depends on order)	OFF	Finished floor level (FFL)
ET	Min. distance back	RM	Grid height
FD	Ceiling clearance	STH	Max. headroom (depends on order)
FFS	Spring tensioning clearance	WE	Shaft centre from lintel
FL	Track clearance		
FPUL	Spring buffers below the track		
FT	Clearance for door operation		

Door weights for roof loads:

SPU F42 / APU F42 Thermo / ALR F42 Thermo	= 320 N/m ²
APU F42 / ALR F42	= 280 N/m ²
ALR F42 Glazing / ALR F42 Vitraplan / ALR F42 Vitraplan AT	= 560 N/m ²

Observe min. sideroom, see page 82.

	STH	WE	DA	BW min.	BW max.
NA 1	400	140	(BW + 80) - (RM + 207)	RM + 320	7820, DE - 80
NA 2	450	160	(BW + 105) - (RM + 207)	RM + 345	7995, DE - 105

FT	DE	B	FFS
885	STH + RM	RM - 310	min. 90° (745)

FD	FL	FTL	LH
DA + 65	230	670	RM + 207

ET**		
NA 1 / NA 2	RM + 395	Manual operation with short spring buffer
	RM + 665	Shaft operator with long spring buffer

** Simplified calculation

Notes:

- Observe the permissible size ranges of the door types on pages 10–15 and 18–35 under all circumstances!
- The clearance required for fitting the door must be free of supply lines, heater fans, etc.
- If using the spring buffer below the track, the clear height under the track in the area of the spring buffer is reduced by 70 mm.

* Note:

Observe clear passage height LDH, see page 54.

Track Application: ND

Normal track application

With inclination up to max. 30°

Detailed technical data can be found in the product configurator.

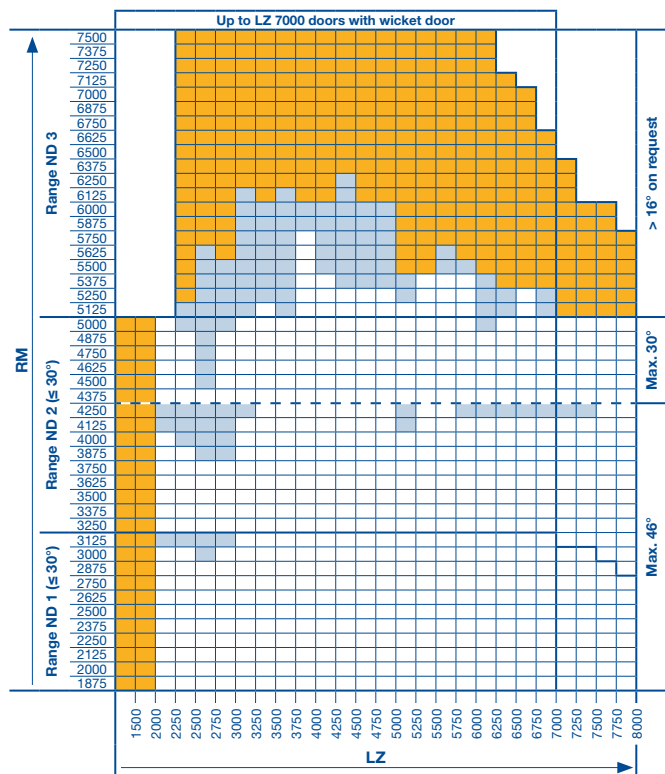
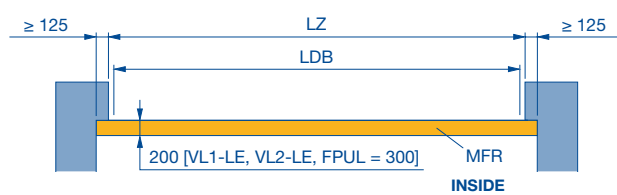
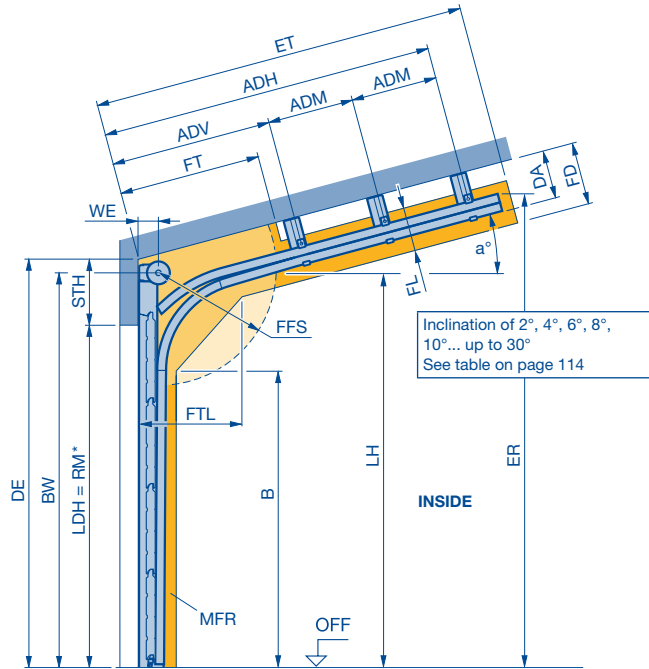

a°	Inclination	FTL	Clearance door section in the double radius
ADH	Distance to rear ceiling anchor	LDB	Clear passage width with ThermoFrame (see page 82)
ADM	Distance to central ceiling anchor	LDH	Clear passage height
ADV	Distance to ceiling anchor, front	LH	Track height
B	Start of double radius	LZ	Clear frame dimensions (from 1200)
BW	Position of shaft support	MFR	Space for fitting the door
DA	Distance to ceiling on request	OFF	Finished floor level (FFL)
DE	Ceiling height	RM	Grid height
ER	Corner point, top edge of track (depth and height)	STH	Min. headroom
ET	Min. distance back	WE	Shaft centre from lintel
FD	Ceiling clearance		
FFS	Spring tensioning clearance		
FL	Track clearance		
FPUL	Spring buffers below the track		
FT	Clearance for door operation		

Door weights for roof loads:

SPU F42 / APU F42 Thermo / ALR F42 Thermo	= 320 N/m ²
APU F42 / ALR F42	= 280 N/m ²
ALR F42 Glazing / ALR F42 Vitraplan / ALR F42 Vitraplan AT	= 560 N/m ²

Observe min. sideroom, see page 82.

	STH	WE	BW	FT	FTL
ND 1, ≤ 30°	410	140	RM + 330	1250, < 16°	670, < 16°
ND 2, ≤ 30°	440	160	RM + 335	1000, ≥ 16°	500, ≥ 16°
ND 3, ≤ 30°	550		RM + 415	1250, < 16°	670, < 16°
With double spring shaft	760	180	RM + 415	1000, ≥ 16°	500, ≥ 16°

ET	DA	DE	FFS	FD	FL	LH	ER	B
**	**	STH + RM	min. 90° (745)	DA + 65	230	**	**	**

** Dimensions can be found in the product configurator.

Note:

- The validity tables with the size range shown are based on the standard door type version (see product description). In case of deviations, the valid size ranges in the product configurator must be taken into account.
- The clearance required for fitting the door must be free of supply lines, heater fans, etc.
- If using the spring buffer below the track, the clear height under the track in the area of the spring buffer is reduced by 70 mm.

* Note:

Observe clear passage height LDH, see page 54.

Note:

- Observe the permissible size ranges of the door types on pages 10–15 and 18–35 under all circumstances!
- ALR F42 Vitraplan and ALR F42 Glazing on request.
- To determine the roof slope see page 114.
- Door types APU F42, ALR F42, APU F42 Thermo and ALR F42 Thermo with glazing A3, M3, S3, U3, LB, P, XU and wicket door on request.
- Inclination on request for RM ≤ 4250 and > 30° or RM > 4250 and > 16°.

All door types available in any version.

Versions with glazing A3, M3, S3, U3, LB, P, XU and / or wicket door.

All door types in any version on request.

Dimensions in mm

Track Application: ND

Normal track application

with inclination from 32° up to max. 46°

Detailed technical data can be found in the product configurator.

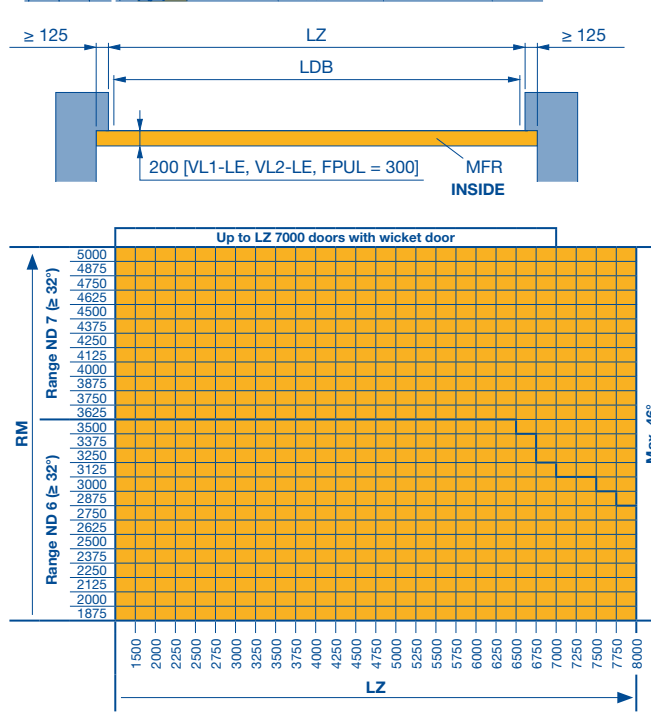
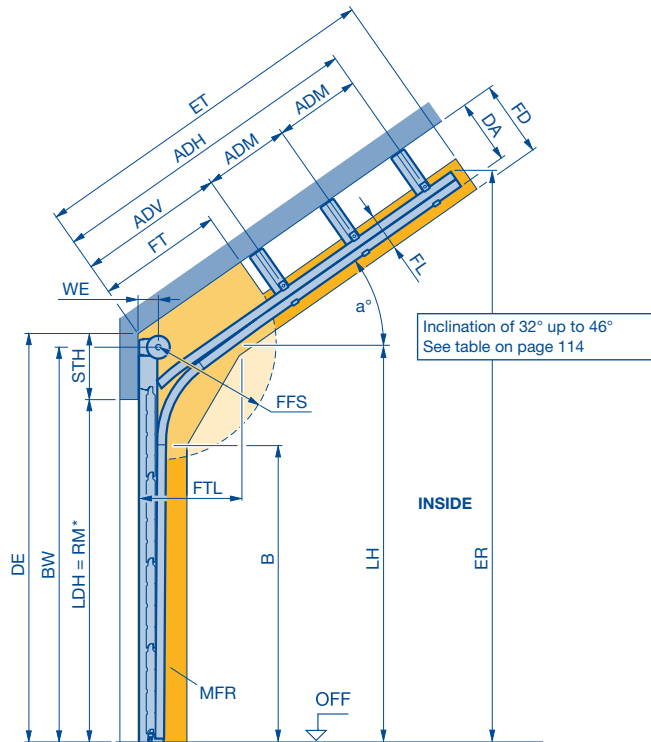

a°	Inclination	FTL	Clearance door section in the double radius
ADH	Distance to rear ceiling anchor	LDB	Clear passage width with ThermoFrame (see page 82)
ADM	Distance to central ceiling anchor	LDH	Clear passage height
ADV	Distance to ceiling anchor, front	LH	Track height
B	Start of double radius	LZ	Clear frame dimensions (from 1200)
BW	Position of shaft support	MFR	Space for fitting the door
DA	Distance to ceiling on request	OFF	Finished floor level (FFL)
DE	Ceiling height	RM	Grid height
ER	Corner point, top edge of track (depth and height)	STH	Min. headroom
ET	Min. distance back	WE	Shaft centre from lintel
FD	Ceiling clearance		
FFS	Spring tensioning clearance		
FL	Track clearance		
FPUL	Spring buffers below the track		
FT	Clearance for door operation		

Door weights for roof loads:

SPU F42 / APU F42 Thermo / ALR F42 Thermo	= 320 N/m ²
APU F42 / ALR F42	= 280 N/m ²
ALR F42 Glazing / ALR F42 Vitraplan / ALR F42 Vitraplan AT	= 560 N/m ²

Observe min. sideroom, see page 82.

	STH	WE	BW	FT	FTL
ND 6, ≥ 32°	490	160	RM + 385	885	500
ND 7, ≥ 32°	510		RM + 405		

ET	DA	DE	FFS	FD	FL	LH	ER	B
**	**	STH + RM	min. 90° (745)	DA + 65	230	**	**	**

** Dimensions can be found in the product configurator.

Note:

- The validity tables with the size range shown are based on the standard door type version (see product description). In case of deviations, the valid size ranges in the product configurator must be taken into account.
- The clearance required for fitting the door must be free of supply lines, heater fans, etc.
- If using the spring buffer below the track, the clear height under the track in the area of the spring buffer is reduced by 70 mm.

* Note:

Observe clear passage height LDH, see page 54.

Note:

- Observe the permissible size ranges of the door types on pages 10–15 and 18–35 under all circumstances!

All door types in any version on request.

Dimensions in mm

Track application: NS

Normal track application

with double radius

Detailed technical data can be found in the product configurator.

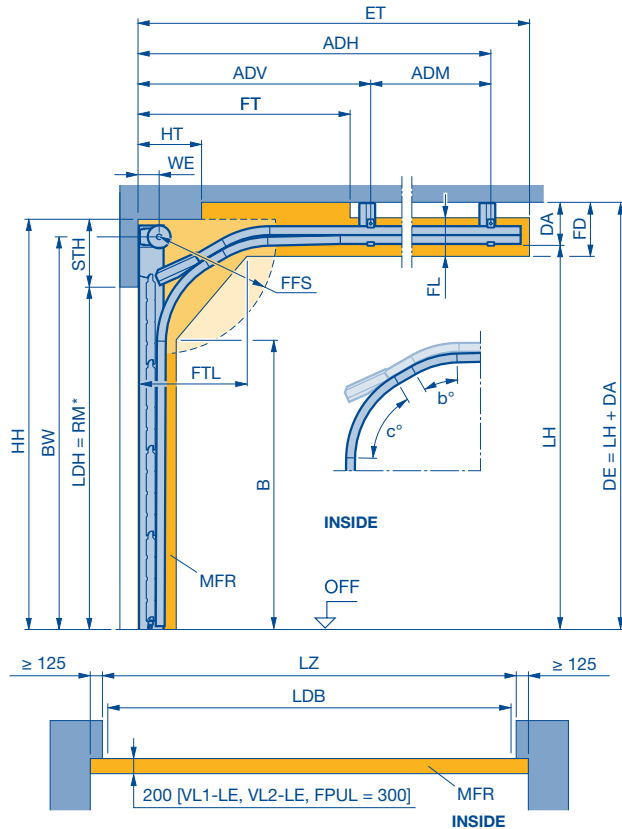

b°/c°	Contour angle	HH	Obstruction height
ADH	Distance to rear ceiling anchor	HT	Obstruction depth
ADM	Distance to central ceiling anchor	LH	Track height
ADV	Distance to ceiling anchor, front	LDB	Clear passage width with ThermoFrame (see page 82)
B	Start of double radius	LDH	Clear passage height
BW	Position of shaft support	LZ	Clear frame dimensions (from 1200)
DA	Min. distance to ceiling	MFR	Space for fitting the door
DE	Ceiling height	OFF	Finished floor level (FFL)
ET	Min. distance back on request	RM	Grid height
FD	Ceiling clearance	STH	Min. headroom (see page 56)
FFS	Spring tensioning clearance	WE	Shaft centre from lintel
FPUL	Spring buffers below the track		
FT	Clearance for door operation		
FTL	Clearance door section in the double radius		

Door weights for roof loads:

SPU F42 / APU F42 Thermo / ALR F42 Thermo	= 320 N/m ²
APU F42 / ALR F42	= 280 N/m ²
ALR F42 Glazing / ALR F42 Vitraplan / ALR F42 Vitraplan AT	= 560 N/m ²

Observe min. sideroom, see page 82.

Note:

- A technical inspection is required!
- The validity tables with the size range shown are based on the standard door type version (see product description). In case of deviations, the valid size ranges in the product configurator must be taken into account.
- The clearance required for fitting the door must be free of supply lines, heater fans, etc.
- If using the spring buffer below the track, the clear height under the track in the area of the spring buffer is reduced by 70 mm.

* Note:

Observe clear passage height LDH, see page 54.

Note:

- Observe the permissible size ranges of the door types on pages 10–15 and 18–35 under all circumstances!
- ALR F42 Vitraplan and ALR F42 Glazing on request

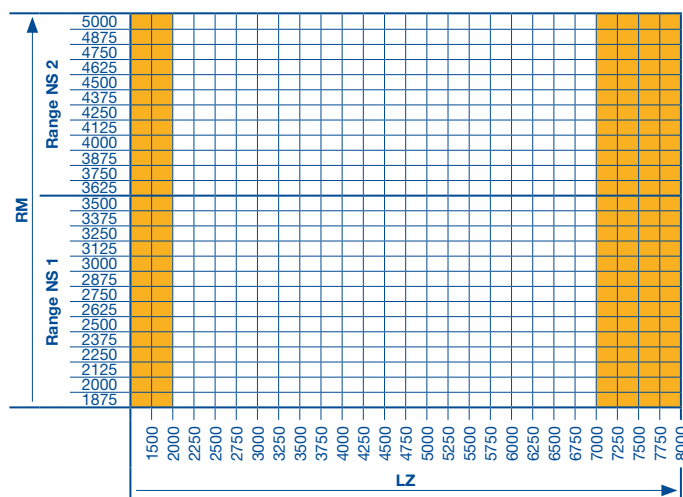

	STH	WE	DA	BW
NS 1	390	140	**	RM + 310
NS 2	440	160	**	RM + 335

FT	DE	B	ET	FFS	FD	FL	FTL	LH
885	LH + 185	**	**	min. 90° (745)	DA + 65	230	**	**

** Dimensions can be found in the product configurator.

□ All door types available in any version.

■ All door types in any version on request.

Dimensions in mm

Track application: NK

Normal track application

with double radius and inclination up to max. 30°

Detailed technical data can be found in the product configurator.

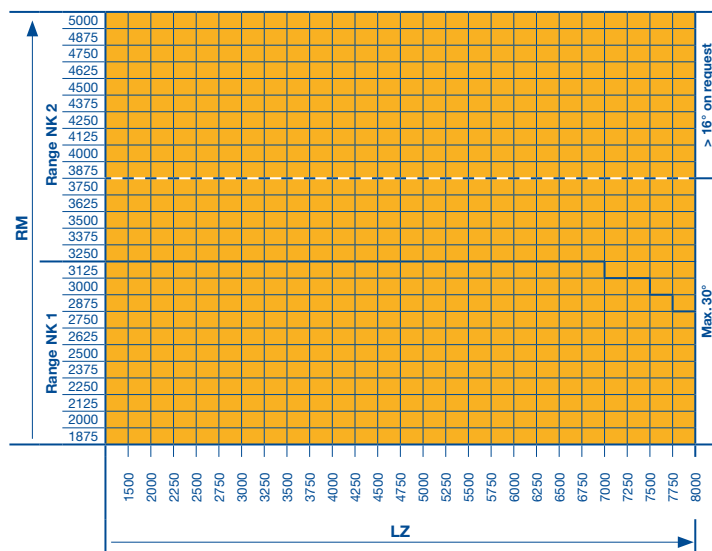
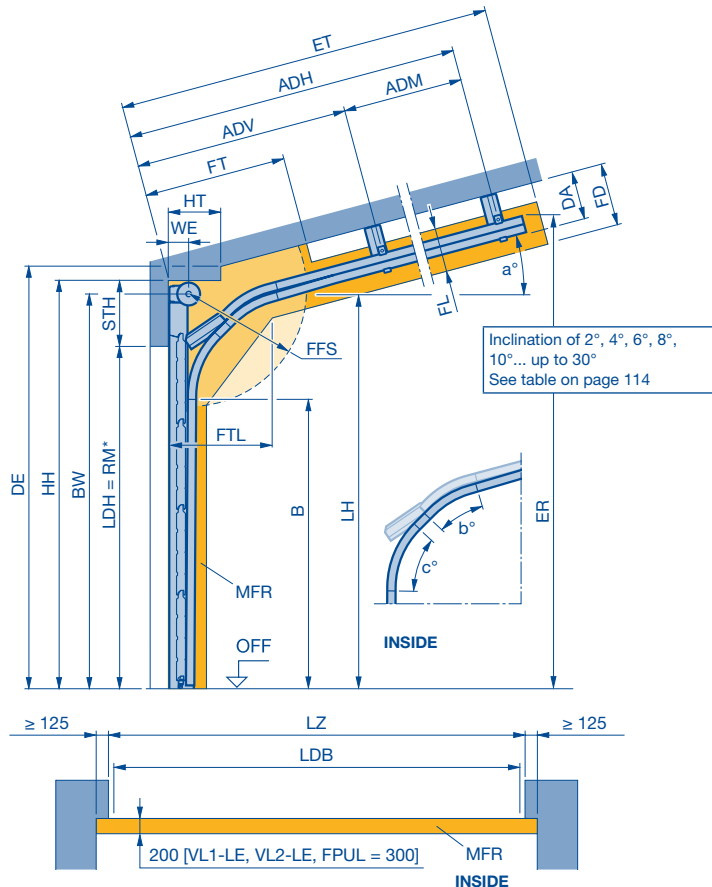

a°	Inclination	FT	Clearance for door operation
b°/c°	Contour angle	FTL	Clearance door section in the double radius
ADH	Distance to rear ceiling anchor	HH	Obstruction height
ADM	Distance to central ceiling anchor	HT	Obstruction depth
ADV	Distance to ceiling anchor, front	LDB	Clear passage width with ThermoFrame (see page 82)
B	Start of double radius	LDH	Clear passage height
BW	Position of shaft support	LH	Track height
DA	Distance to ceiling on request	LZ	Clear frame dimensions (from 1200)
DE	Ceiling height	MFR	Space for fitting the door
ER	Top edge corner point	OFF	Finished floor level (FFL)
ET	Min. distance back	RM	Grid height
FD	Ceiling clearance	STH	Min. headroom
FFS	Spring tensioning clearance	WE	Shaft centre from lintel
FL	Track clearance		
FPUL	Spring buffers below the track		

Door weights for roof loads:

SPU F42 / APU F42 Thermo / ALR F42 Thermo	= 320 N/m ²
APU F42 / ALR F42	= 280 N/m ²
ALR F42 Glazing / ALR F42 Vitraplan / ALR F42 Vitraplan AT	= 560 N/m ²

Observe min. sideroom, see page 82.

Notes:

- A technical inspection is required!
- The validity tables with the size range shown are based on the standard door type version (see product description). In case of deviations, the valid size ranges in the product configurator must be taken into account.
- The clearance required for fitting the door must be free of supply lines, heater fans, etc.
- If using the spring buffer below the track, the clear height under the track in the area of the spring buffer is reduced by 70 mm.
- Observe the permissible size ranges of the door types on pages 10 – 15 and 18 – 35 under all circumstances!
- ALR F42 Vitraplan and ALR F42 Glazing on request.
- To determine the roof slope see page 114.

* Note:

Observe clear passage height LDH, see page 54.

	STH	WE	DA	BW
NK 1	390	140	**	RM + 310
NK 2	440	160	**	RM + 335

FT	DE	B	ET	FFS	FD	FL	FTL	LH
885	LH + 185	**	**	min. 90° (745)	DA + 65	230	**	**

** Dimensions can be found in the product configurator.

All door types in any version on request.

Dimensions in mm

Track application: NH

Normal track application with minimum high-lift

Detailed technical data can be found in the product configurator.

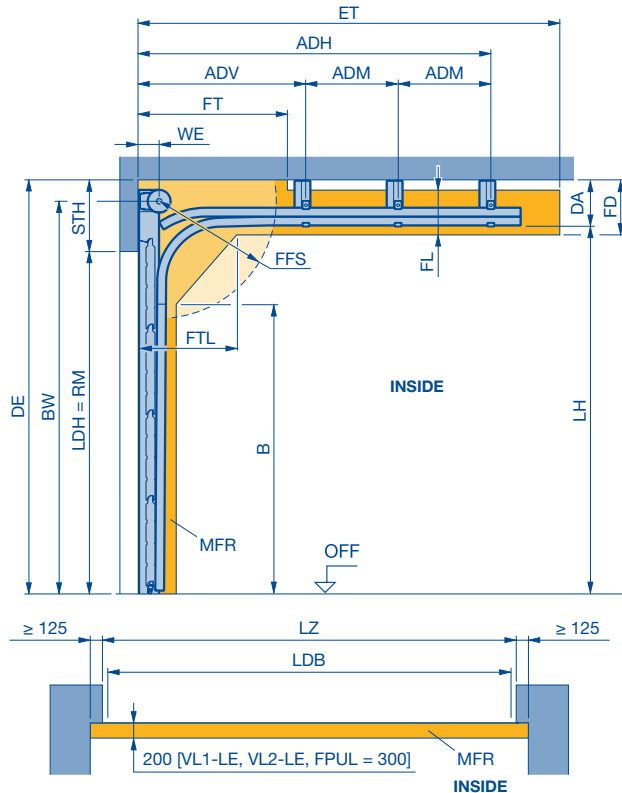

ADH	Distance to rear ceiling anchor	L	Anchor length
ADM	Distance to central ceiling anchor	LDB	Clear passage width with ThermoFrame (see page 82)
ADV	Distance to ceiling anchor, front	LDH	Clear passage height
B	Start of double radius	LH	Track height
BW	Position of shaft support	LZ	Clear frame dimensions (from 1200)
DA	Min. distance to ceiling	MFR	Space for fitting the door
DE	Ceiling height	OFF	Finished floor level (FFL)
ET	Min. distance back	RM	Grid height
FD	Ceiling clearance	STH	Min. headroom
FFS	Spring tensioning clearance	WE	Shaft centre from lintel
FL	Track clearance	RM	Grid height
FPUL	Spring buffers below the track	STH	Min. headroom
FT	Clearance for door operation	WE	Shaft centre from lintel
FTL	Clearance door section in the double radius		

Door weights for roof loads:

SPU F42 / APU F42 Thermo / ALR F42 Thermo	= 320 N/m ²
APU F42 / ALR F42	= 280 N/m ²
ALR F42 Glazing / ALR F42 Vitraplan / ALR F42 Vitraplan AT	= 560 N/m ²

Observe min. sideroom, see page 82.

Notes:

- The validity tables with the size range shown are based on the standard door type version (see product description). In case of deviations, the valid size ranges in the product configurator must be taken into account.
- The clearance required for fitting the door must be free of supply lines, heater fans, etc.
- If using the spring buffer below the track, the clear height under the track in the area of the spring buffer is reduced by 70 mm.
- Observe the permissible size ranges of the door types on pages 10 – 15 and 18 – 35 under all circumstances!
- ALR F42 Vitraplan and ALR F42 Glazing on request

	STH	WE	DA	BW
NH 1	569	140	225	LH + 140
NH 2	634	160	290	LH + 180
NH 3	709		365	
With double spring shaft	760	180	565	LH + 225

FT	DE	B	FFS	FD	FL	FTL	LH	ET
1150	STH + RM	LH - 366	min. 90° (745)	DA + 65	250	645	min. RM + 344 max. = RM + 490	**

** Dimensions can be found in the product configurator.

□ All door types available in any version.

■ All door types in any version on request.

Dimensions in mm

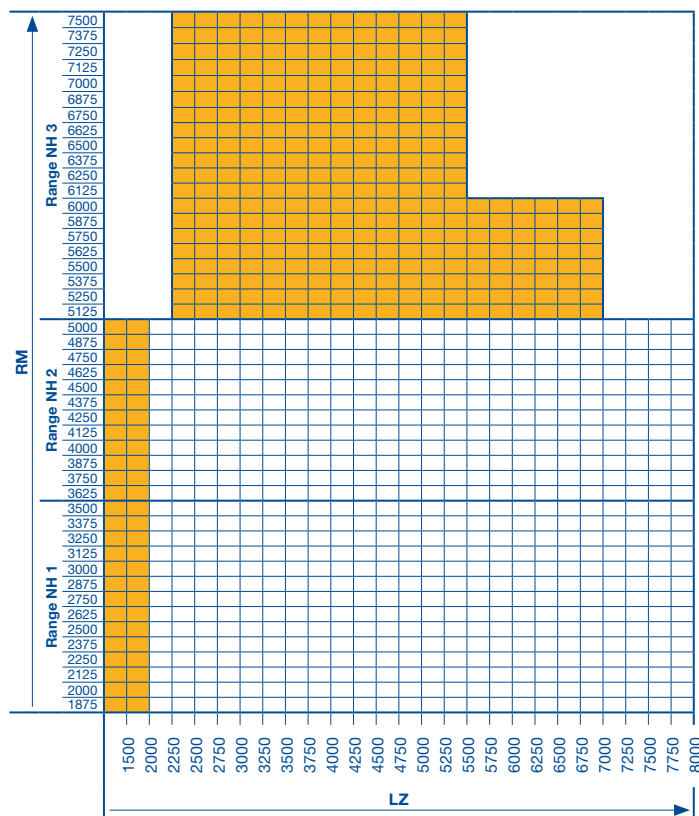

Track Application: GD

Normal track application

with inclination up to max. 28

Minimum high-lift

Detailed technical data can be found in the product configurator.

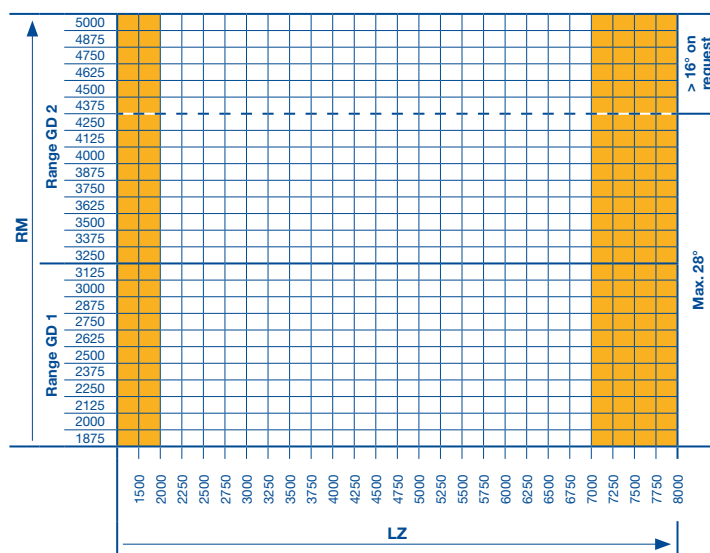
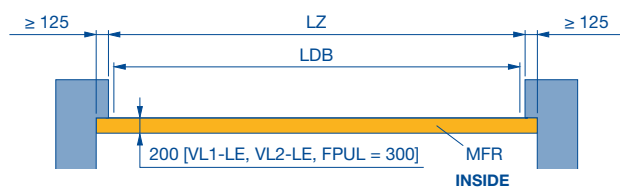
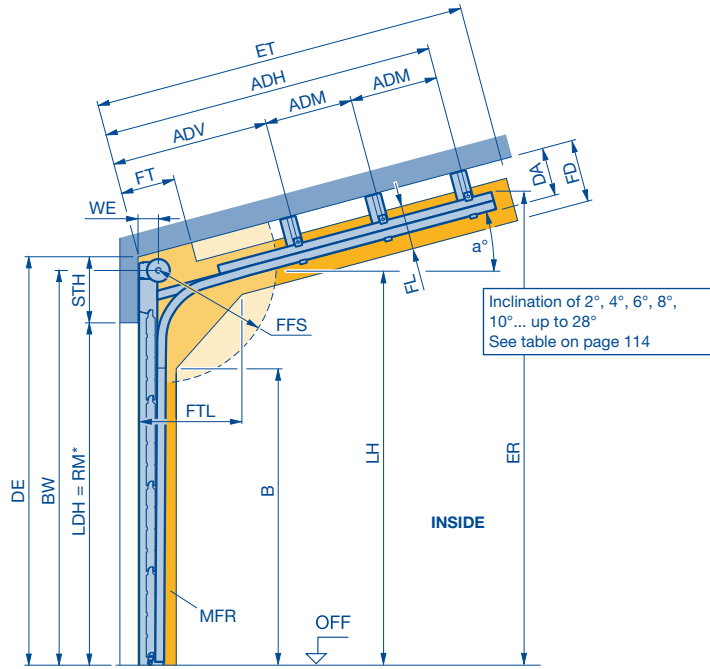

a°	Inclination	FPUL	Spring buffers below the track
ADH	Distance to rear ceiling anchor	FT	Clearance for door operation
ADM	Distance to central ceiling anchor	FTL	Clearance door section in the double radius
ADV	Distance to ceiling anchor, front	LDB	Clear passage width with ThermoFrame (see page 82)
B	Start of double radius, factory specification	LDH	Clear passage height
BW	Position of shaft support	LH	Track height
DA	Distance to ceiling on request	LZ	Clear frame dimensions (from 1200)
DE	Ceiling height	MFR	Space for fitting the door
ER	Top edge corner point	OFF	Finished floor level (FFL)
FD	Track height (depth and height)	RM	Grid height
FFS	Spring tensioning clearance	STH	Min. headroom
FL	Track clearance	WE	Shaft centre from lintel

Door weights for roof loads:

SPU F42 / APU F42 Thermo / ALR F42 Thermo	= 320 N/m ²
APU F42 / ALR F42	= 280 N/m ²
ALR F42 Glazing / ALR F42 Vitraplan / ALR F42 Vitraplan AT	= 560 N/m ²

Observe min. sideroom, see page 82.

Notes:

- The validity tables with the size range shown are based on the standard door type version (see product description). In case of deviations, the valid size ranges in the product configurator must be taken into account.
- The clearance required for fitting the door must be free of supply lines, heater fans, etc.
- If using the spring buffer below the track, the clear height under the track in the area of the spring buffer is reduced by 70 mm.
- Observe the permissible size ranges of the door types on pages 10 – 15 and 18 – 35 under all circumstances!
- ALR F42 Vitraplan and ALR F42 Glazing on request.
- To determine the roof slope see page 114.

	STH	WE	DA	BW	FT	DE
GD 1	569	140	**	LH + 140	2 × WE	STH + RM
GD 2	634	160		LH + 180		

ET	B	FFS	FD	FL	FTL	LH	ER
**	LH-366	min. 90° (745)	DA + 65	250	645	min. RM + 344 max. = RM + 490	**

** Dimensions can be found in the product configurator.

All door types available in any version.

All door types in any version on request.

Dimensions in mm

Track application: GS

Normal track application with double radius and minimum high-lift

Detailed technical data can be found in the product configurator.

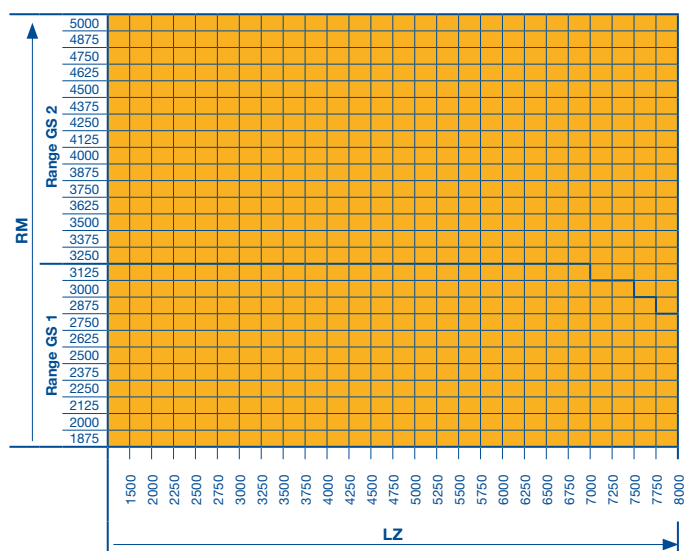
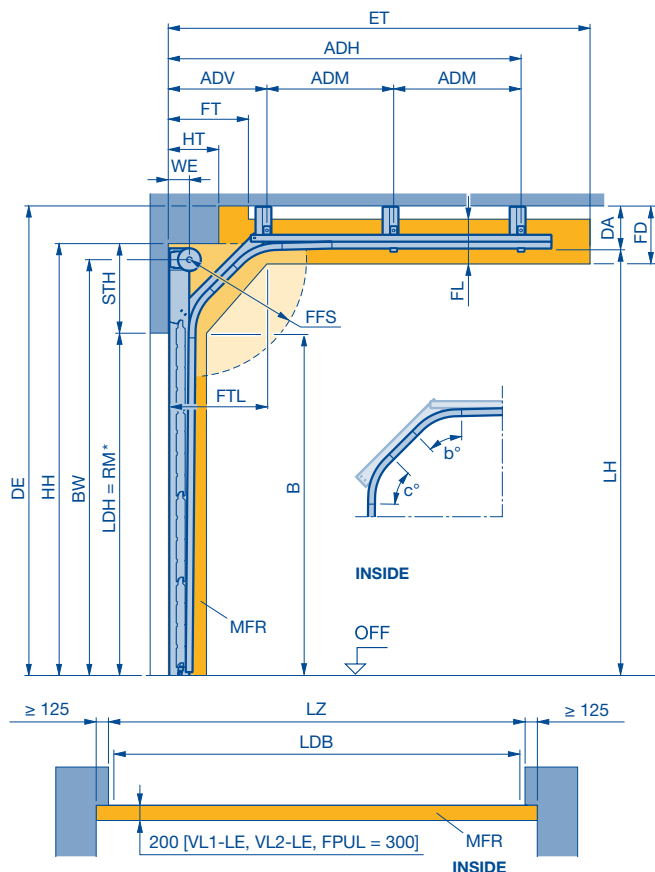

b°/c° Contour angle	FTL Clearance door section in the double radius
ADH Distance to rear ceiling anchor	HH Obstruction height
ADM Distance to central ceiling anchor	HT Obstruction depth
ADV Distance to ceiling anchor, front	LDB Clear passage width with ThermoFrame (see page 82)
B Start of double radius, factory specification	LDH Clear passage height
BW Position of shaft support	LH Track height
DA Distance to ceiling on request	LZ Clear frame dimensions (from 1200)
DE Ceiling height	MFR Space for fitting the door
ET Min. distance back	OFF Finished floor level (FFL)
FD Ceiling clearance	RM Grid height
FFS Spring tensioning clearance	STH Min. headroom
FL Track clearance	WE Shaft centre from lintel
FPUL Spring buffers below the track	
FT Clearance for door operation	

Door weights for roof loads:

SPU F42 / APU F42 Thermo / ALR F42 Thermo	= 320 N/m ²
APU F42 / ALR F42	= 280 N/m ²
ALR F42 Glazing / ALR F42 Vitraplan / ALR F42 Vitraplan AT	= 560 N/m ²

Observe min. sideroom, see page 82.

Notes:

- A technical inspection is required!
- The validity tables with the size range shown are based on the standard door type version (see product description). In case of deviations, the valid size ranges in the product configurator must be taken into account.
- The clearance required for fitting the door must be free of supply lines, heater fans, etc.
- If using the spring buffer below the track, the clear height under the track in the area of the spring buffer is reduced by 70 mm.
- Observe the permissible size ranges of the door types on pages 10–15 and 18–35 under all circumstances!
- ALR F42 Vitraplan and ALR F42 Glazing on request.
- To determine the roof slope see page 114.

	STH	WE	DA	BW	FT	DE
GS 1	567	140	**	B + 510	2 × WE	LH + 185
GS 2	617	160		B + 535		

FFS	FD	FL	FTL	LH	ET
min. 90° (745)	DA + 65	250	**	**	**

** Dimensions can be found in the product configurator.

All door types in any version on request.

Dimensions in mm

Track application: GK

Normal track application

with double radius and inclination up to max. 30°

Minimum high-lift

Detailed technical data can be found in the product configurator.

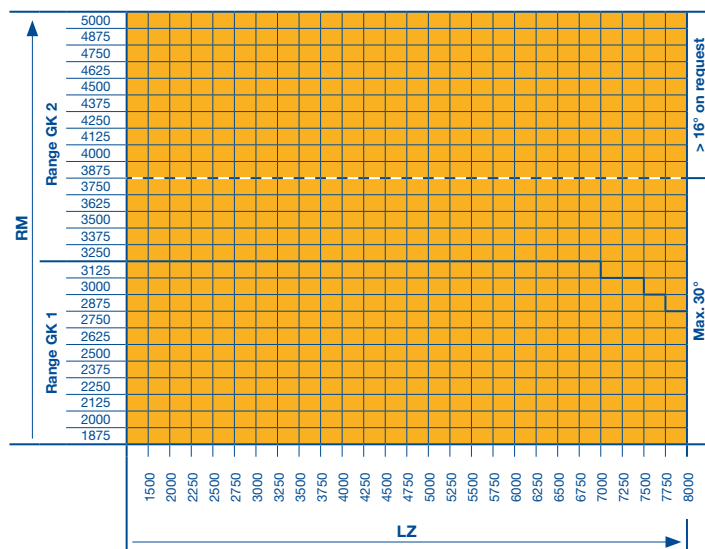
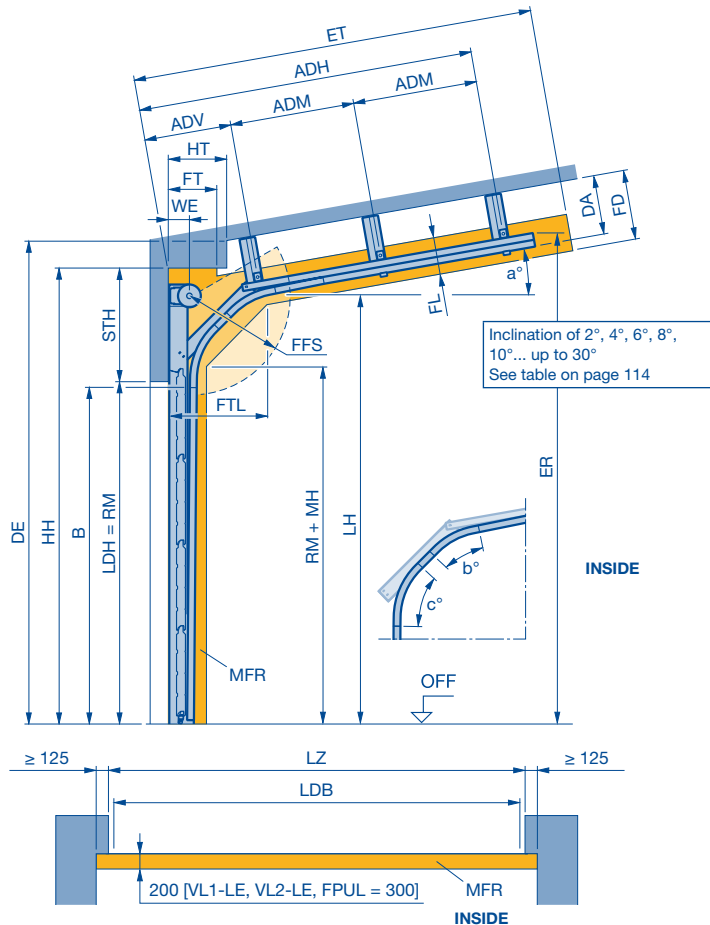

a°	Inclination	FPUL	Spring buffers below the track
b°/c°	Contour angle	FT	Clearance for door operation
ADH	Distance to rear ceiling anchor	FTL	Clearance door section in the double radius
ADM	Distance to central ceiling anchor	HH	Obstruction height
ADV	Distance to ceiling anchor, front	HT	Obstruction depth
B	Start of double radius, factory specification	LDB	Clear passage width with ThermoFrame (see page 82)
BW	Position of shaft support	LDH	Clear passage height
DA	Distance to ceiling on request	LH	Track height
DE	Ceiling height	LZ	Clear frame dimensions (from 1200)
ER	Top edge corner point	MFR	Space for fitting the door
ET	Track height (depth and height)	OFF	Finished floor level (FFL)
FL	Track clearance	RM	Grid height
FFS	Spring tensioning clearance	STH	Min. headroom
FT	Clearance for door operation	WE	Shaft centre from lintel

Door weights for roof loads:

SPU F42 / APU F42 Thermo / ALR F42 Thermo	= 320 N/m ²
APU F42 / ALR F42	= 280 N/m ²
ALR F42 Glazing / ALR F42 Vitraplan / ALR F42 Vitraplan AT	= 560 N/m ²

Observe min. sideroom, see page 82.

Notes:

- A technical inspection is required!
- The validity tables with the size range shown are based on the standard door type version (see product description). In case of deviations, the valid size ranges in the product configurator must be taken into account.
- The clearance required for fitting the door must be free of supply lines, heater fans, etc.
- If using the spring buffer below the track, the clear height under the track in the area of the spring buffer is reduced by 70 mm.
- Observe the permissible size ranges of the door types on pages 10 – 15 and 18 – 35 under all circumstances!
- ALR F42 Vitraplan and ALR F42 Glazing on request.
- To determine the roof slope see page 114.

	STH	WE	DA	BW	FT	DE
GK 1	567	140	**	B + 510	2 x WE	LH + 185
GK 2	617	160	**	B + 535		

FFS	FD	FL	FTL	LH	ET
min. 90° (745)	DA + 65	250	**	**	**

** Dimensions can be found in the product configurator.

All door types in any version on request.

Dimensions in mm

Track application: L

Low headroom track application

Detailed technical data can be found in the product configurator.

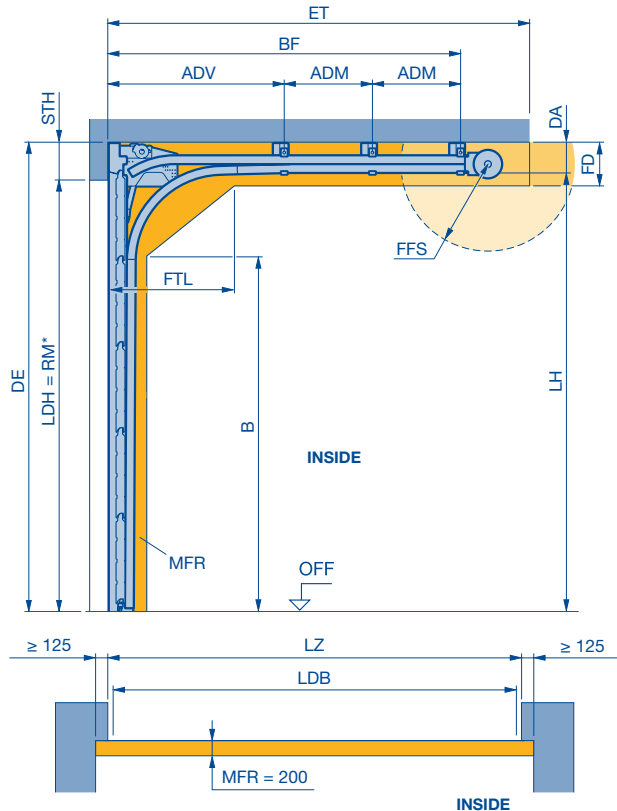

MFR = 260	Trap protection for swivel mechanism RM < 2800
MFR = 300	Leading photocell VL1/VL2

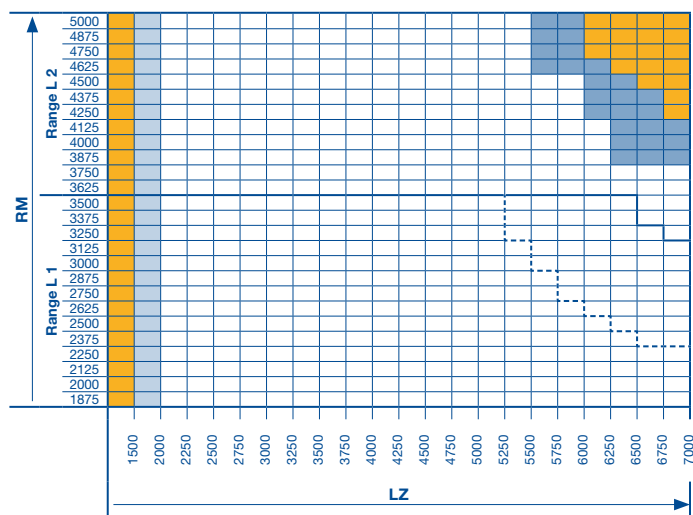

ADM	Distance to central ceiling anchor	LH	Track height
ADV	Distance to ceiling anchor, front	LDB	Clear passage width with ThermoFrame (see page 82)
B	Start of double radius	LDH	Clear passage height
BF	Position of spring shaft	LZ	Clear frame dimensions (from 1200)
ET	Min. distance back	MFR	Space for fitting the door
DA	Min. distance to ceiling	OFF	Finished floor level (FFL)
DE	Min. ceiling height	RM	Grid height
FD	Min. ceiling clearance	STH	Min. headroom
FFS	Spring tensioning clearance		
FTL	Clearance door section in the double radius		

Door weights for roof loads:

SPU F42 / APU F42 Thermo / ALR F42 Thermo	= 320 N/m ²
APU F42 / ALR F42	= 280 N/m ²
ALR F42 Glazing / ALR F42 Vitraplan / ALR F42 Vitraplan AT	= 560 N/m ²

Observe min. sideroom, see page 82.

Door operation:

- Manually operated: rope or chain hoist (recommended for manual operation!)
- Power-driven: WA 500 / 500 FU only with chain box! ITO or SupraMatic HT only possible without swivel mechanism!
- There may be restrictions in the passage height of up to 40 mm in the area of the lock when using the swivel mechanism and door lock for outside and inside operation.

B	BF***	DA**	DE	ET***
LH - 517	RM + 752	156	STH + RM	RM + 1066
FD	FFS	FTL	LH	STH
DA + 65	min. 90° (745)	650	RM + 45	200 210 (WA 300)

** ≥ 500 – 1092 suspension in special length
> 1092 base construction required

*** With swivel mechanism ET = RM + 969 and BF = RM + 656

Notes:

- The validity tables with the size range shown are based on the standard door type version (see product description). In case of deviations, the valid size ranges in the product configurator must be taken into account.
- The clearance required for fitting the door must be free of supply lines, heater fans, etc.
- Observe the permissible size ranges of the door types on pages 10 – 15 and 18 – 35 under all circumstances!
- ALR F42 Vitraplan and ALR F42 Glazing on request

* Note:

Observe clear passage height LDH, see page 54.

All door types available in any version.

All door types in any version on request.

Door types APU F42, ALR F42, APU F42 Thermo, ALR F42 Thermo as well as versions with glazing A3, M3, S3, U3, LB, P, XU and wicket door on request.

Versions with glazing A3, M3, S3, U3, LB, P, XU and / or wicket door.

Track limit

Track limit for door types APU F42 Thermo, ALR F42 Thermo as well as versions with glazing A3, M3, S3, U3, LB, P, XU and wicket door

Dimensions in mm

Track Application: LD

Low headroom track application
with inclination up to max. 30°

Detailed technical data can be found in the product configurator.

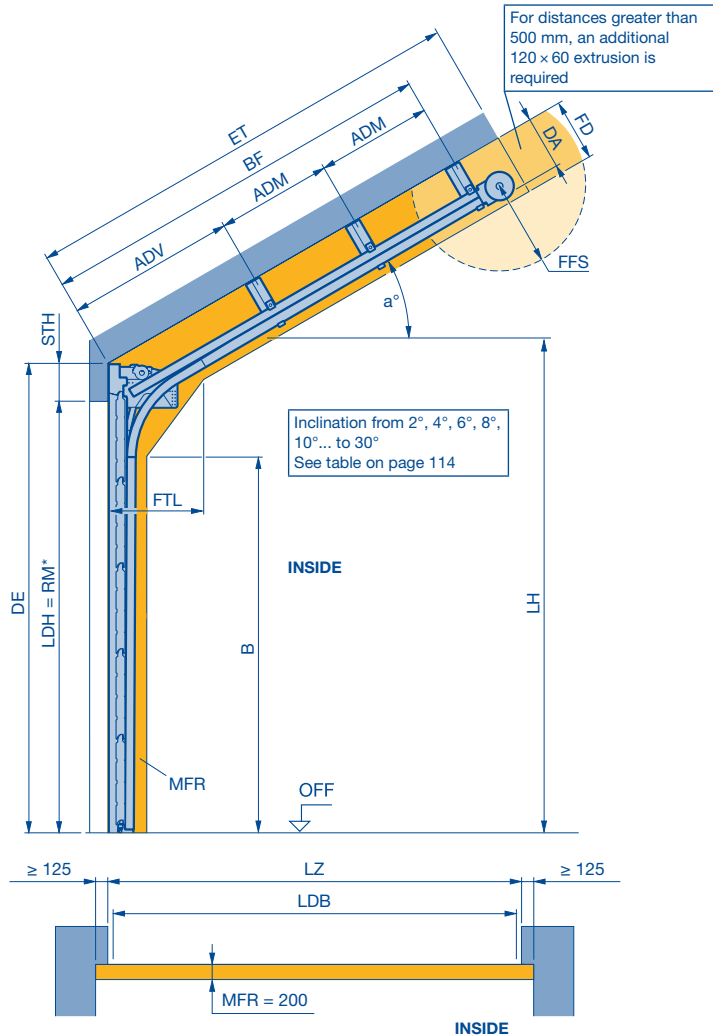

MFR = 260	Trap protection for swivel mechanism RM < 2800
MFR = 300	Leading photocell VL1/VL2

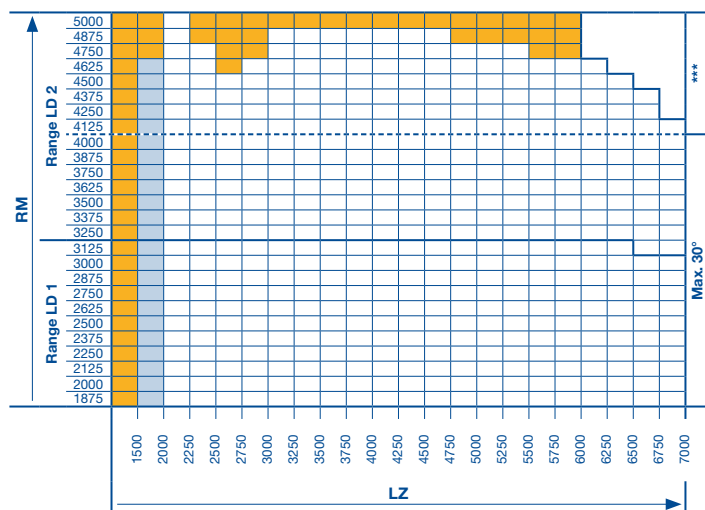

a°	Inclination	FTL	Clearance door section in the double radius
ADM	Distance to central ceiling anchor on request	LDB	Clear passage width with ThermoFrame (see page 82)
ADV	Distance to ceiling anchor, front	LDH	Clear passage height
B	Start of double radius on request	LZ	Clear frame dimensions (from 1200)
BF	Position of spring shaft on request	MFR	Space for fitting the door
DA	Distance to ceiling on request	OFF	Finished floor level (FFL)
DE	Min. ceiling height	RM	Grid height
ET	Min. distance back	STH	Min. headroom
FD	Min. ceiling clearance		
FFS	Spring tensioning clearance		

Door weights for roof loads:

SPU F42 / APU F42 Thermo / ALR F42 Thermo	= 320 N/m ²
APU F42 / ALR F42	= 280 N/m ²
ALR F42 Glazing / ALR F42 Vitraplan / ALR F42 Vitraplan AT	= 560 N/m ²

Observe min. sideroom, see page 82.

Door operation:

- Manually operated: rope or chain hoist (recommended for manual operation!)
- Power-driven: WA 400 / 500 FU only with chain box! ITO or SupraMatic HT only possible without swivel mechanism!
- There may be restrictions in the passage height of up to 40 mm in the area of the lock when using the swivel mechanism and door lock for outside and inside operation.

Notes:

- The validity tables with the size range shown are based on the standard door type version (see product description). In case of deviations, the valid size ranges in the product configurator must be taken into account.
- The clearance required for fitting the door must be free of supply lines, heater fans, etc.
- Observe the permissible size ranges of the door types on pages 10 – 15 and 18 – 35 under all circumstances!
- ALR F42 Vitraplan and ALR F42 Glazing on request.
- To determine the roof slope see page 114.
- Door types APU F42, ALR F42, APU F42 Thermo, ALR F42 Thermo as well as versions with glazing A3, M3, S3, U3, LB, P, XU and wicket door on request.

* Notes:

- Observe clear passage height LDH, see page 84.
- The swivel mechanism is only possible up to 10°.

	DE	LH	STH	FD
LD 1 / LD 2	STH + RM	**	200	DA + 65

	B	DA	FFS	FTL
**	**	**	min 90° (745)	650

** Dimensions can be found in the product configurator.

	ET		
LD 1 / LD 2	(RM + 1064) - (3,6 × a°)	a° = 2° - 16°	without swivel mechanism
	(RM + 1103) - (6,6 × a°)	a° = 18° - 30°	without swivel mechanism
	(RM + 969) - (2,6 × a°)	a° = 2° - 10°	with swivel mechanism

□ All door types available in any version.

■ All door types in any version on request.

▨ Versions with glazing A3, M3, S3, U3, LB, P, XU and / or wicket door.

— Track limit

*** > 16° on request

Dimensions in mm

Track Application: HA

High-lift track application

With high-mounted torsion spring shaft

Detailed technical data can be found in the product configurator.

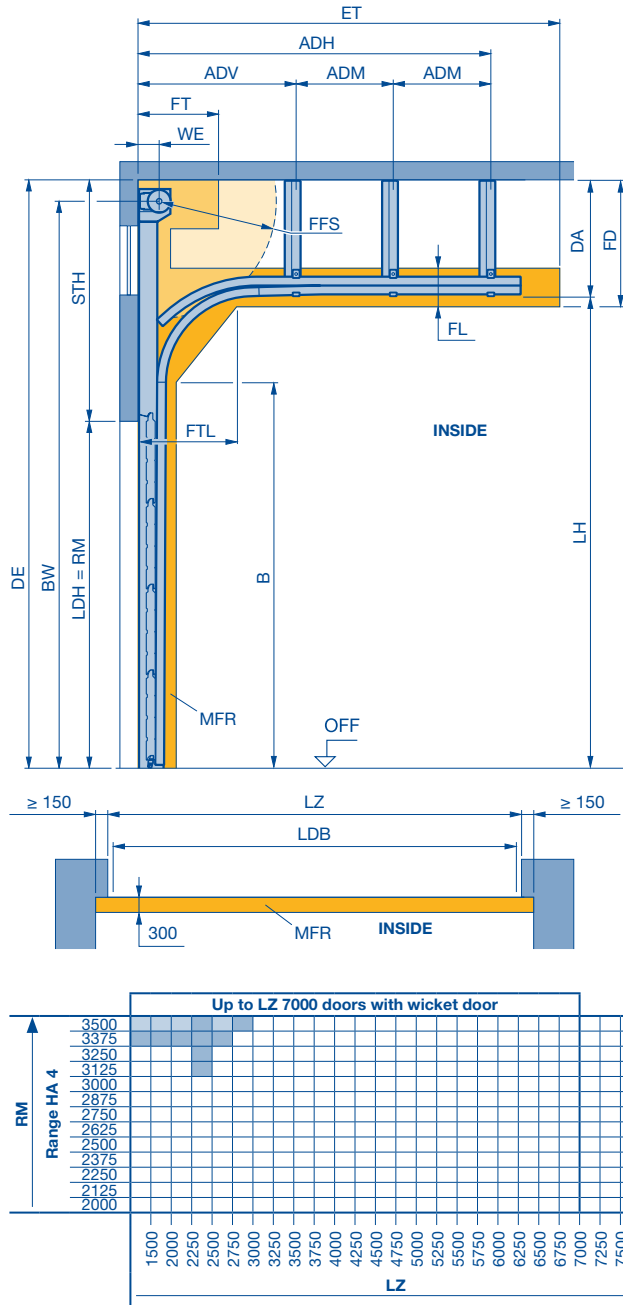

ADH	Distance to rear ceiling anchor	FTL	Clearance door section in the double radius
ADM	Distance to central ceiling anchor (see page 88)	LDB	Clear passage width with ThermoFrame (see page 82)
ADV	Distance to ceiling anchor, front	LDH	Clear passage height
B	Start of double radius	LH	Track height
BW	Position of shaft support	LZ	Clear frame dimensions (from 1200)
DA	Min. distance to ceiling	MFR	Space for fitting the door
DE	Min. ceiling height	OFF	Finished floor level (FFL)
ET	Min. distance back	RM	Grid height
FD	Ceiling clearance	STH	Min. headroom
FFS	Spring tensioning clearance	WE	Shaft centre from lintel
FL	Track clearance		
FT	Clearance for door operation		

Please note:
Select required track height according to the door height in table.

- Note:**
- The validity tables with the size range shown are based on the standard door type version (see product description). In case of deviations, the valid size ranges in the product configurator must be taken into account.
 - The clearance required for fitting the door must be free of supply lines, heater fans, etc.
 - If using the spring buffer below the track, the clear height under the track in the area of the spring buffer is reduced by 70 mm.

Observe min. sideroom, see page 82.

	STH	DA	DE	B	BW min.
HA 4	(BW + 140) - RM	(BW + 140) - LH	STH + RM	LH - 513	LH + 150

BW max.	WE	FT	FTL	FL	FFS	FD
8120, DE - 140	160	2 × WE	650	250	min. 90° (745)	DA + 65

Table: Track heights (LH)

Door height RM	Min. LH	Max. LH	HA 4
3500	3990	6215	
3375	3865	5965	
3250	3740	5715	
3125	3615	5465	
3000	3490	5215	
2875	3365	4965	
2750	3240	4715	
2625	3115	4465	
2500	2990	4215	
2375	2865	3965	
2250	2740	3715	
2125	2615	3465	
2000	2490	3215	

- Notes:**
- Observe the permissible size ranges of the door types on pages 10 – 15 and 18 – 35 under all circumstances!
 - ALR F42 Vitraplan and ALR F42 Glazing on request

ET*		
HA 4	$2 \times RM - LH + 962 + 297$	For manual operation with long spring buffer (standard)
	$2 \times RM - LH + 692 + 297$	For shaft operator with long spring buffer, $LH - RM \leq 1000$
	$2 \times RM - LH + 692 + 297$	For shaft operator WA 300 with long spring buffer, $LH - RM > 1000$
	$2 \times RM - LH + 692 + 27$	For shaft operator WA 500 / WA 500 FU with short spring buffer, $LH - RM > 1000$

* Simplified calculation

- All door types available in any version.
 - All door types available, versions with glazing A3, M3, S3, U3, LB, P, XU and / or wicket door on request.
 - Door types APU F42 and ALR F42 are possible; APU F42 Thermo, ALR F42 Thermo and SPU F42 with thermo frames as well as versions with glazing A3, M3, S3, U3, LB, P, XU and / or wicket door on request.
- Dimensions in mm

Track Application: HD

High-lift track application

with inclination up to max. 30

Detailed technical data can be found in the product configurator.

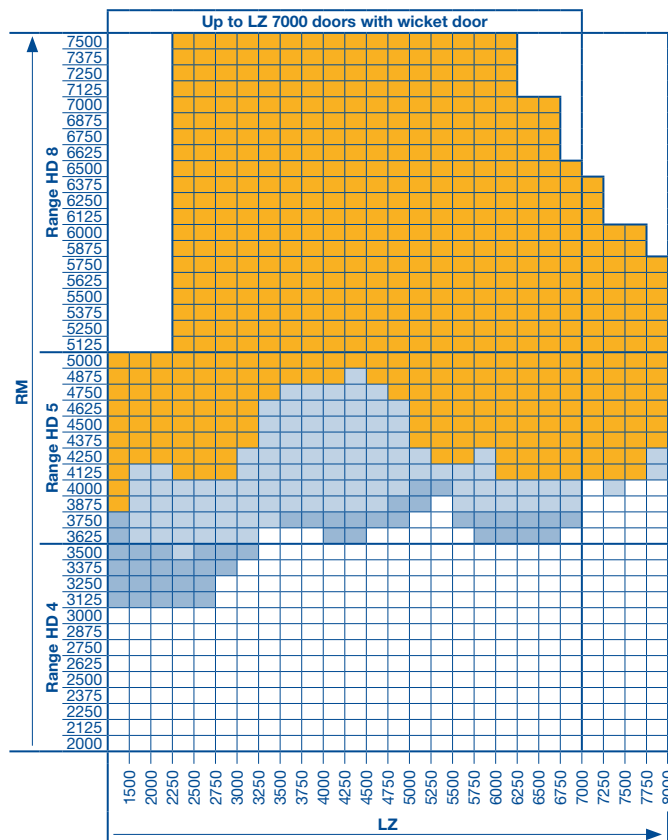
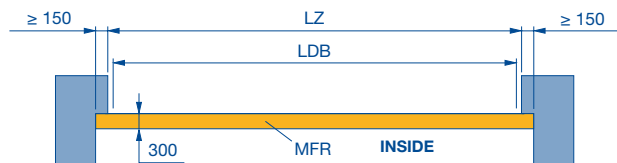
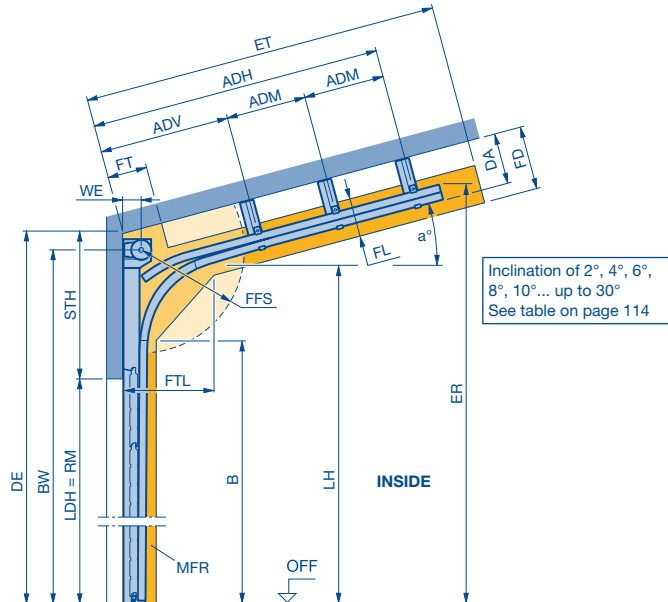

a°	Inclination	FT	Clearance for door operation
ADH	Distance to rear ceiling anchor	FTL	Clearance door section in the double radius
ADM	Distance to central ceiling anchor on request	HH	Obstruction height
ADV	Distance to ceiling anchor, front	HT	Obstruction depth
B	Start of double radius	LDB	Clear passage width with ThermoFrame (see page 82)
BW	Position of shaft support	LDH	Clear passage height
DA	Distance to ceiling on request	LH	Track height
DE	Min. ceiling height	LZ	Clear frame dimensions (from 1200)
ER	Top edge corner point	MFR	Space for fitting the door
ET	Track height (depth and height)	OFF	Finished floor level (FFL)
FD	Min. distance back	RM	Grid height
FFS	Ceiling clearance	STH	Min. headroom
FL	Spring tensioning clearance	WE	Shaft centre from lintel

Please note:

Select required track height according to the door height in the table on page 68.

Notes:

- The validity tables with the size range shown are based on the standard door type version (see product description). In case of deviations, the valid size ranges in the product configurator must be taken into account.
- The clearance required for fitting the door must be free of supply lines, heater fans, etc.
- If using the spring buffer below the track, the clear height under the track in the area of the spring buffer is reduced by 70 mm.
- Observe the permissible size ranges of the door types on pages 10–15 and 18–35 under all circumstances!
- ALR F42 Vitraplan and ALR F42 Glazing on request.
- To determine the roof slope see page 114.
- Inclination > 10° to 30° on request.

Observe min. sideroom, see page 82.

	STH	BW	WE	DA	B
HD 4	780	LH + 150	160	**	LH - 513
HD 5	840	LH + 180	180		
HD 8	880	LH + 205	205		

	FT	FL	FTL	FFS	FD	ET	ER
2 × WE		250	650, < 16° 550, ≥ 16°	min. 90° (745)	DA + 65	**	**

** Dimensions can be found in the product configurator.

- All door types available in any version.
- All door types available, versions with glazing A3, M3, S3, U3, LB, P, XU and / or wicket door on request.
- Door types APU F42 and ALR F42 are possible; APU F42 Thermo, ALR F42 Thermo and SPU F42 with thermo frames as well as versions with glazing A3, M3, S3, U3, LB, P, XU and / or wicket door on request.
- All door types in any version on request.

Dimensions in mm

Track application: HS

High-lift track application

with double radius

Detailed technical data can be found in the product configurator.

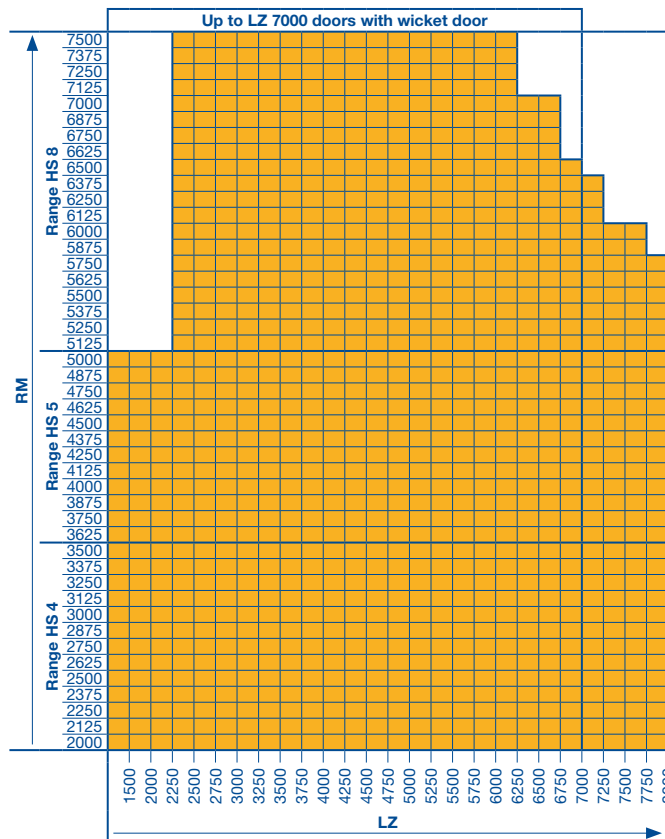
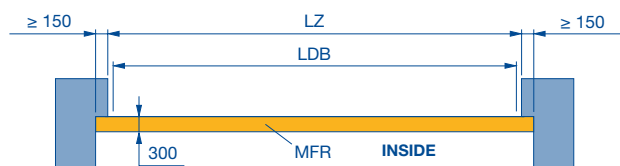
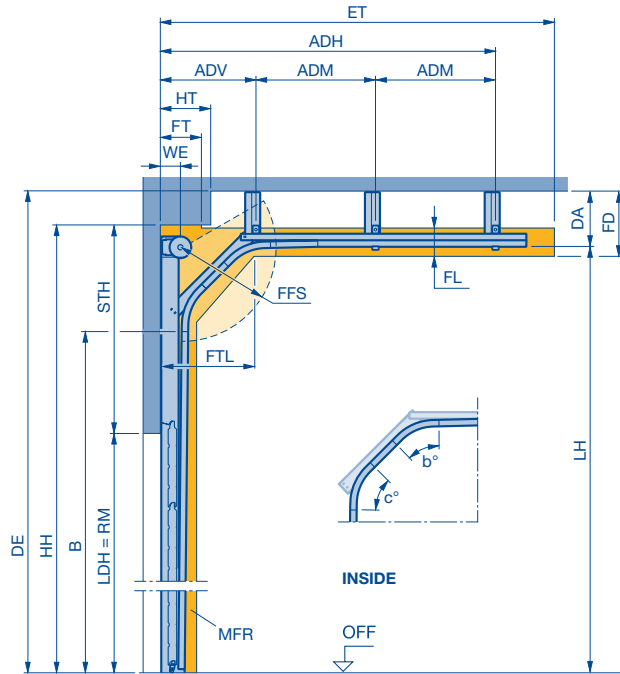

b°/c° Contour angle	FTL Clearance door section in the double radius
ADH Distance to rear ceiling anchor	FFW Spring shaft clearance
ADM Distance to central ceiling anchor	HH Obstruction height
ADV Distance to ceiling anchor, front	HT Obstruction depth
B Start of double radius, factory specification	LDB Clear passage width with ThermoFrame (see page 82)
DA Distance to ceiling on request	LDH Clear passage height
DE Min. ceiling height	LH Track height
ET Distance back	LZ Clear frame dimensions (from 1200)
FD Ceiling clearance	MFR Space for fitting the door
FFS Spring tensioning clearance	OFF Finished floor level (FFL)
FL Track clearance	RM Grid height
FT Clearance for door operation, on request	STH Min. headroom (see page 56)
	WE Shaft centre from lintel

Please note:

Select required track height according to the door height in the table on page 68.

Note:

- A technical inspection is required!
- The validity tables with the size range shown are based on the standard door type version (see product description). In case of deviations, the valid size ranges in the product configurator must be taken into account.
- The clearance required for fitting the door must be free of supply lines, heater fans, etc.

Notes:

- Observe the permissible size ranges of the door types on pages 10–15 and 18–35 under all circumstances!
- ALR F42 Vitraplan and ALR F42 Glazing on request

Observe min. sideroom, see page 82.

	STH	WE	DA	DE	B
HS 4	785	160	**	LH + 185	**
HS 5	812	180			
HS 8	852	205			

BW	FT	FL	FTL	FFS	FD	ET	ER
**	2 x WE	250	**	min. 90° (745)	DA + 65	**	**

** Dimensions can be found in the product configurator.

All door types in any version on request.

Dimensions in mm

Track application: HK

High-lift track application

with double radius and inclination up to max. 30°

Detailed technical data can be found in the product configurator.

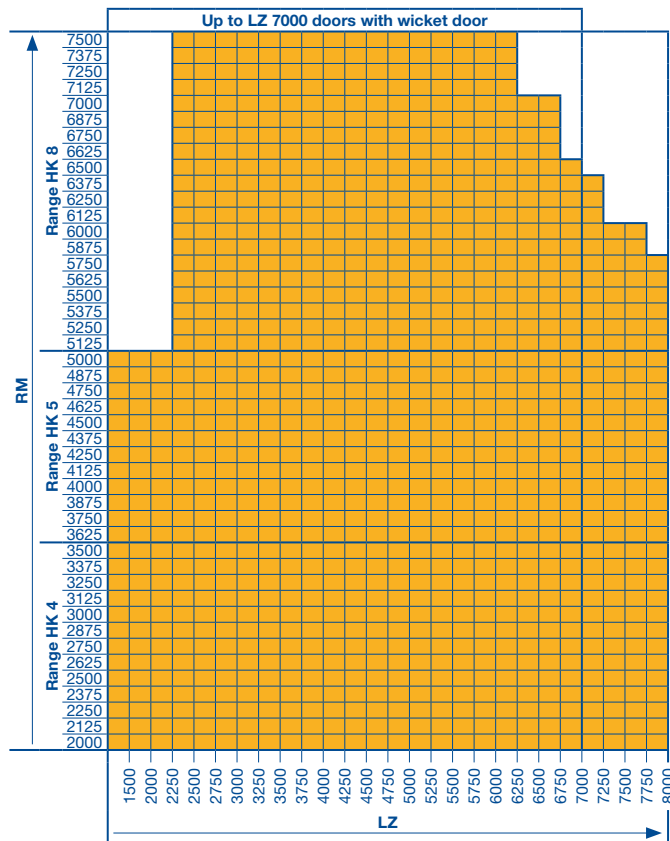
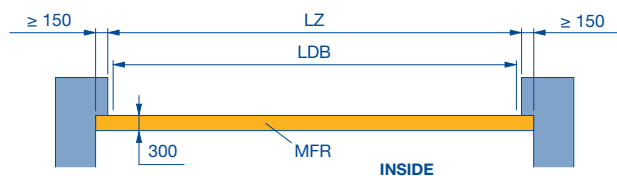
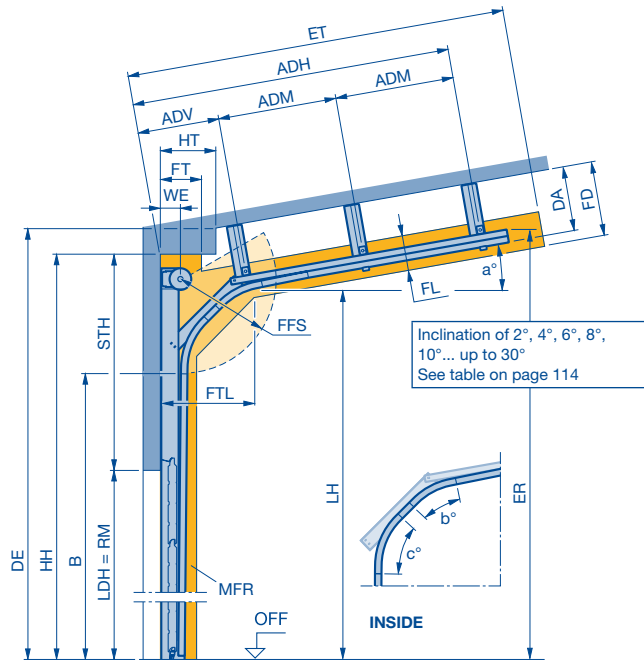

a°	Inclination	FTL	Clearance door section in the double radius
b°/c°	Contour angle	FFW	Spring shaft clearance
ADH	Distance to rear ceiling anchor	HH	Obstruction height
ADM	Distance to central ceiling anchor	HT	Obstruction depth
ADV	Distance to ceiling anchor, front	LDB	Clear passage width with ThermoFrame (see page 82)
B	Start of double radius, factory specification	LDH	Clear passage height
DA	Distance to ceiling on request	LH	Track height
DE	Min. ceiling height	LZ	Clear frame dimensions (from 1200)
ER	Top edge corner point	MFR	Space for fitting the door
	Track height (depth and height)	OFF	Finished floor level (FFL)
FD	Ceiling clearance	RM	Grid height
FFS	Spring tensioning clearance	STH	Min. headroom
FL	Track clearance	WE	Shaft centre from lintel
FT	Clearance for door operation, on request		

Please note:

Select required track height according to the door height in the table on page 68.

Note:

- A technical inspection is required!
- The validity tables with the size range shown are based on the standard door type version (see product description). In case of deviations, the valid size ranges in the product configurator must be taken into account.
- The clearance required for fitting the door must be free of supply lines, heater fans, etc.

Notes:

- Observe the permissible size ranges of the door types on pages 10–15 and 18–35 under all circumstances!
- ALR F42 Vitraplan and ALR F42 Glazing on request.
- To determine the roof slope see page 114.
- Roof slope > 10° to 30° on request.

Observe min. sideroom, see page 82.

	STH	WE	DA	DE	B
HK 4	785	160	**	LH + 185	**
HK 5	812	180			
HK 8	852	205			

BW	FT	FL	FTL	FFS	FD	ET	ER
**	2 x WE	250	**	min. 90° (745)	DA + 65	**	**

** Dimensions can be found in the product configurator.

All door types in any version on request.

Dimensions in mm

Track Application: HU

High-lift track application with low-mounted torsion spring shaft

Detailed technical data can be found in the product configurator.

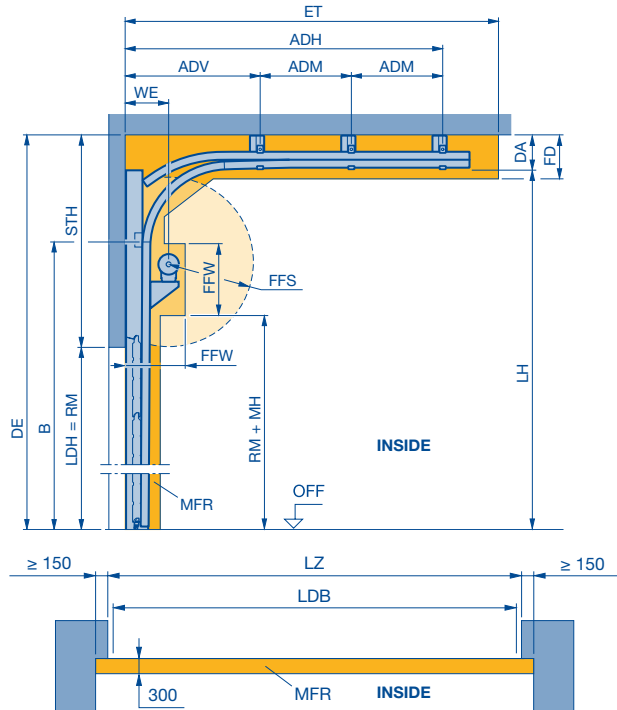

ET*	
HU 4 / HU 5	2 × RM - LH + 962 + 297 For manual operation with long spring buffer (standard)
HU 4 / HU 5	2 × RM - LH + 692 + 297 For shaft operator WA 300 with long spring buffer
HU 4 / HU 5	2 × RM - LH + 692 + 27 For shaft operator WA 500 / WA 500 FU with short spring buffer
HU 8	2 × RM - LH + 692 + 297 All versions

* Simplified calculation.

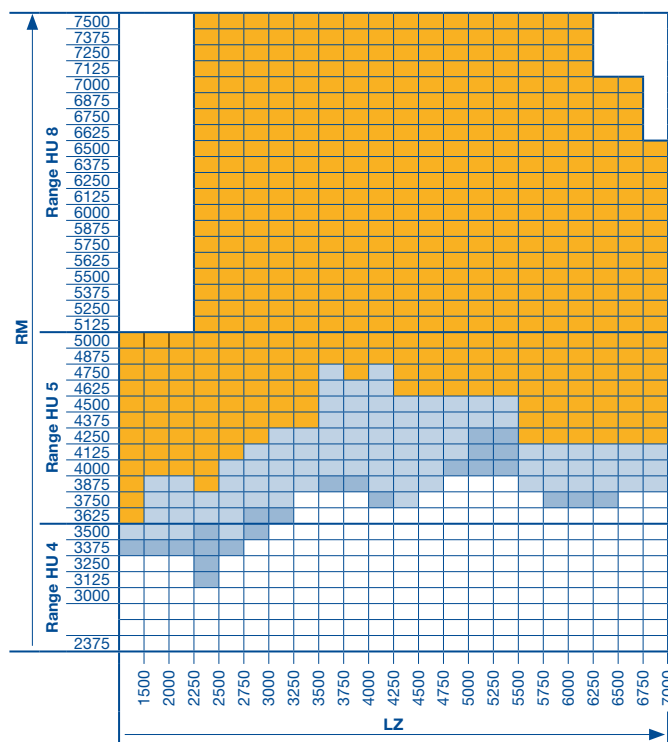

ADH	Distance to rear ceiling anchor	LDB	Clear passage width with ThermoFrame (see page 82)
ADM	Distance to central ceiling anchor	LDH	Clear passage height
ADV	Distance to ceiling anchor, front	LH	Track height
B	Start of double radius	LZ	Clear frame dimensions (from 1200)
DA	Min. distance to ceiling	MFR	Space for fitting the door
DE	Min. ceiling height	MH	Fitting height
ET	Min. distance back	OFF	Finished floor level (FFL)
FD	Min. ceiling clearance	RM	Grid height
FFS	Spring tensioning clearance	STH	Min. headroom (see page 56)
FFW	Spring shaft clearance	WE	Shaft centre from lintel

Please note:

Select required track height according to the door height in table.

Note:

- The validity tables with the size range shown are based on the standard door type version (see product description). In case of deviations, the valid size ranges in the product configurator must be taken into account.
- The clearance required for fitting the door must be free of supply lines, heater fans, etc.

Observe min. sideroom, see page 82.

	STH	WE	DA	FFW
HU 4	LH - RM + 190	315	190	460 × 850
HU 5		335		500 × 850
HU 8		375		580 × 850

B	DE	FD	FFS	MH
LH - 513	STH + RM	DA + 65	min. 90° (745)	400

Table: Track heights (LH)

Door height RM	HU 5		HU 4	HU 8
	Min. LH	Max. LH		
5000	6560	8350		
4875	6435	8225		
4750	6310	8100		
4625	6185	7975		
4500	6060	7850		
4375	5935	7725		
4250	5810	7600		
4125	5685	7475		
4000	5560	7235		
3875	5435	6985		
3750	5310	6735		
3625	5185	6485		
3500	5060	6235		
3375	4935	5985		
3250	4810	5735		
3125	4685	5485		
3000	4560	5235		
2875	4435	4985		
2750	4310	4735		
2625	4185	4485		
2500	4060	4235		
2375	3935	3985		
7500	9060	10250		All door types and versions available on request.
7375	8935	10250		
7250	8810	10250		
7125	8685	10250		
7000	8560	10250		
6875	8435	10250		
6750	8310	10250		
6625	8185	10250		
6500	8060	9950		
6375	7935	9825		
6250	7810	9700		
6125	7685	9575		
6000	7560	9450		
5875	7435	9325		
5750	7310	9200		
5625	7185	9075		
5500	7060	8950		
5375	6935	8825		
5250	6810	8700		
5125	6685	8575		

Notes:

- Observe the permissible size ranges of the door types on pages 10 – 15 and 18 – 35 under all circumstances!
- ALR F42 Vitraplan and ALR F42 Glazing on request

	All door types available in any version.
	All door types available, versions with glazing A3, M3, S3, U3, LB, P, XU and / or wicket door on request.
	Door types APU F42 and ALR F42 are possible; APU F42 Thermo, ALR F42 Thermo and SPU F42 with thermo frames as well as versions with glazing A3, M3, S3, U3, LB, P, XU and / or wicket door on request.
	All door types in any version on request.

Dimensions in mm

Track Application: RD

High-lift track application

with low-mounted torsion spring shaft and inclination up to max. 30°

Detailed technical data can be found in the product configurator.

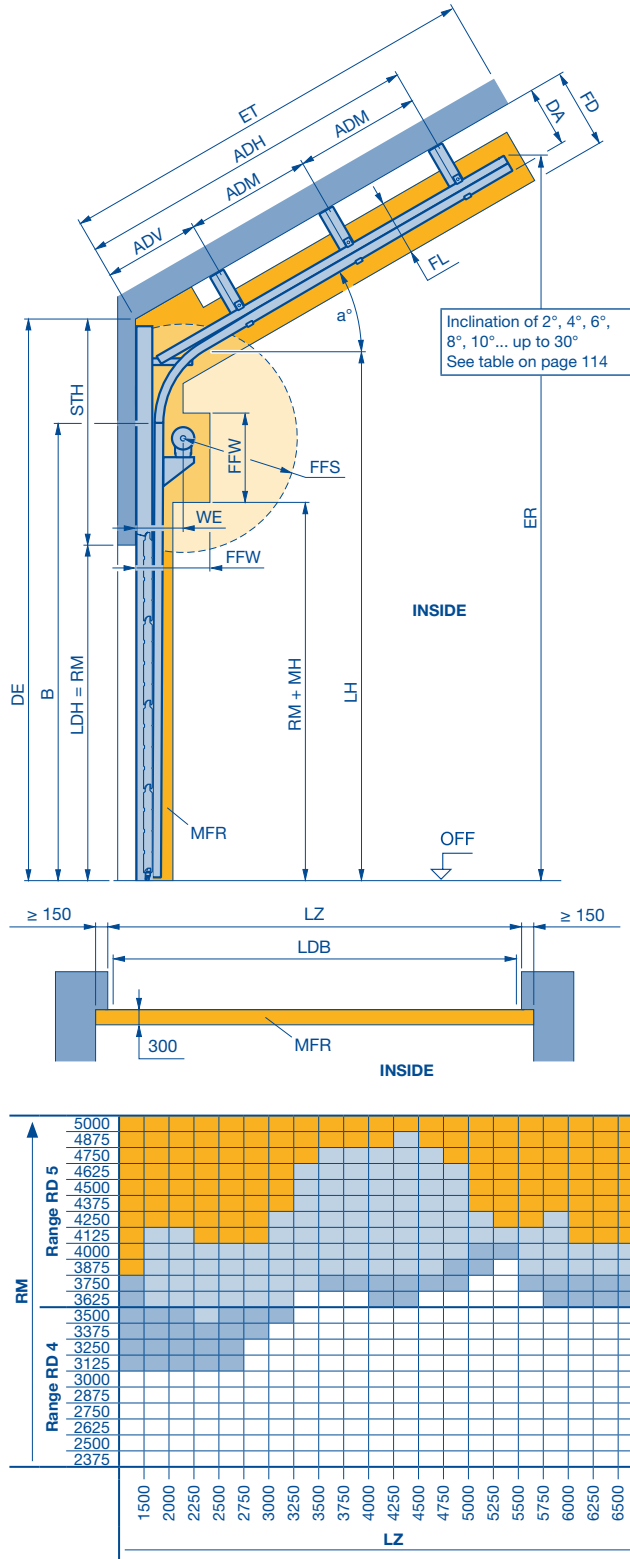

a°	Inclination	FL	Track clearance
ADH	Distance to rear ceiling anchor	LDB	Clear passage width with ThermoFrame (see page 82)
ADM	Distance to central ceiling anchor	LDH	Clear passage height
ADV	Distance to ceiling anchor, front	LH	Track height
B	Start of double radius	LZ	Clear frame dimensions (from 1200)
DA	Distance to ceiling on request	MFR	Space for fitting the door
DE	Min. ceiling height	MH	Fitting height
ER	Top edge corner point	OFF	Finished floor level (FFL)
	Track height (depth and height)	RM	Grid height
ET	Min. distance back	STH	Min. headroom
FD	Ceiling clearance	WE	Shaft centre from lintel
FFS	Spring tensioning clearance		
FFW	Spring shaft clearance		

Please note:

Select required track height according to the door height in the table on page 73.

Note:

- The validity tables with the size range shown are based on the standard door type version (see product description). In case of deviations, the valid size ranges in the product configurator must be taken into account.
- The clearance required for fitting the door must be free of supply lines, heater fans, etc.

Notes:

- Observe the permissible size ranges of the door types on pages 10–15 and 18–35 under all circumstances!
- ALR F42 Vitraplan and ALR F42 Glazing on request.
- To determine the roof slope see page 114.
- Inclination > 10° to 30° on request.

Observe min. sideroom, see page 82.

	WE	FFW	STH	DA	DE
RD 4	315	460 × 850	1750	**	STH + RM
RD 5	335	500 × 850			

B	FFS	FD	FL	ET	ER	MH
LH - 513	min. 90° (745)	DA + 65	250	**	**	400

** Dimensions can be found in the product configurator.

- All door types available in any version.
- All door types available, versions with glazing A3, M3, S3, U3, LB, P, XU and / or wicket door on request.
- Door types APU F42 and ALR F42 are possible; APU F42 Thermo, ALR F42 Thermo and SPU F42 with thermo frames as well as versions with glazing A3, M3, S3, U3, LB, P, XU and / or wicket door on request.
- All door types in any version on request.

Dimensions in mm

Track application: RS

High-lift track application

with double radius and low-mounted torsion spring shaft

Detailed technical data can be found in the product configurator.

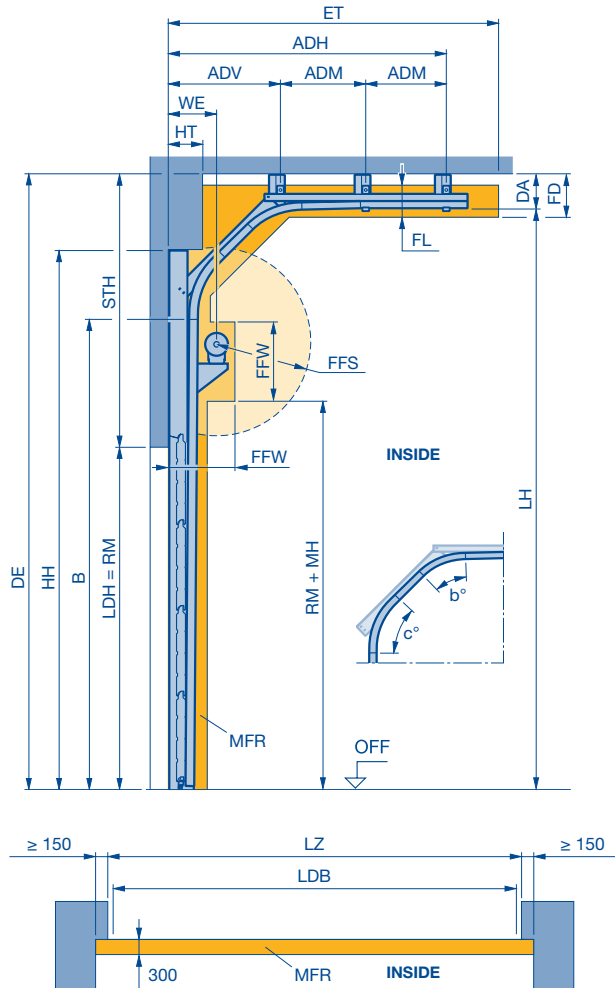

b°/c° Contour angle	HH Obstruction height
ADH Distance to rear ceiling anchor	HT Obstruction depth
ADM Distance to central ceiling anchor	LDB Clear passage width with ThermoFrame (see page 82)
ADV Distance to ceiling anchor, front	LDH Clear passage height
B Start of double radius, factory specification	LH Track height
DA Distance to ceiling on request	LZ Clear frame dimensions (from 1200)
DE Min. ceiling height	MFR Space for fitting the door
ET Distance back	MH Fitting height
FD Ceiling clearance	OFF Finished floor level (FFL)
FFS Spring tensioning clearance	RM Grid height
FFW Spring shaft clearance	STH Min. headroom (see page 56)
FL Track clearance	WE Shaft centre from lintel

Please note:

Select required track height according to the door height in the table on page 73.

Note:

- A technical inspection is required!
- The validity tables with the size range shown are based on the standard door type version (see product description). In case of deviations, the valid size ranges in the product configurator must be taken into account.
- The clearance required for fitting the door must be free of supply lines, heater fans, etc.

Notes:

- Observe the permissible size ranges of the door types on pages 10 – 15 and 18 – 35 under all circumstances!
- ALR F42 Vitraplan and ALR F42 Glazing on request

Observe min. sideroom, see page 82.

	WE	FFW	STH	DA	DE
RS 4	315	460 × 850	1477	183	LH + 183
RS 5	335	500 × 850			

B	FFS	FD	FL	ET	ER	MH
**	min. 90° (745)	DA + 65	250	**	**	400

** Dimensions can be found in the product configurator.

All door types in any version on request.

Dimensions in mm

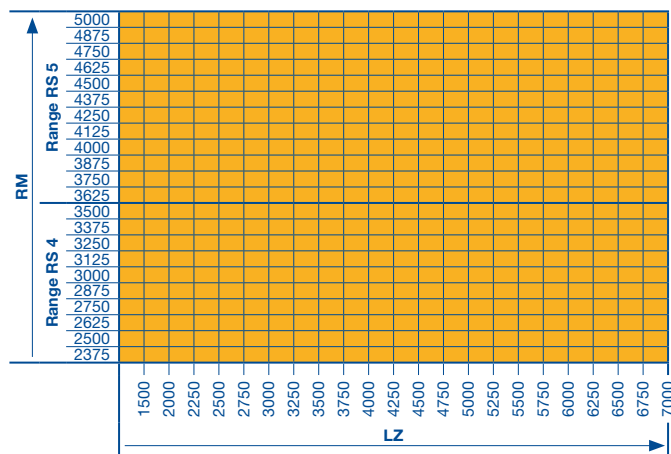

Track application: RK

High-lift track application

with double radius and inclination up to max. 30°

Detailed technical data can be found in the product configurator.

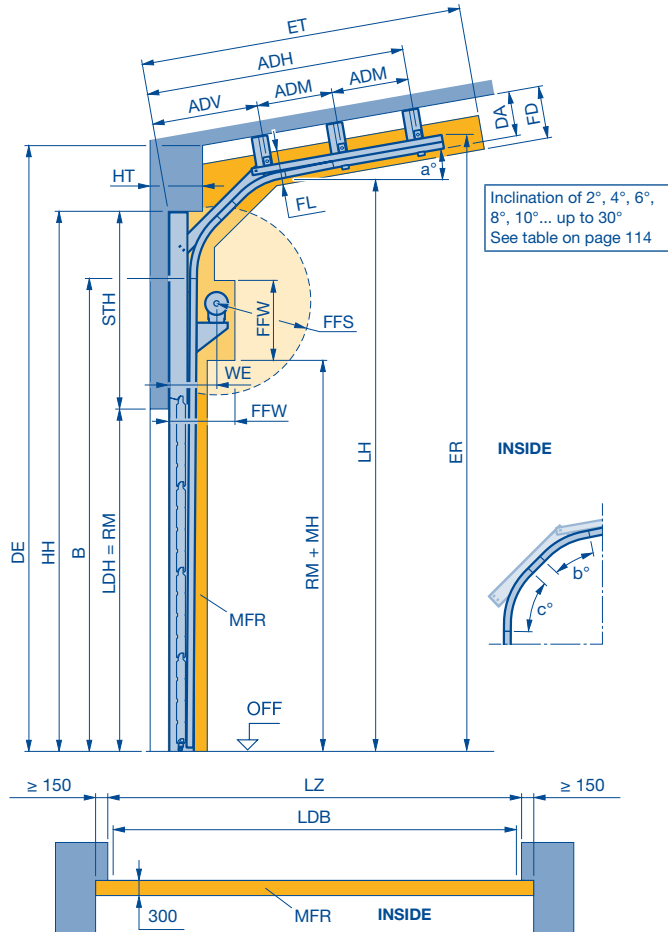

a°	Inclination	FL	Track clearance
b°/c°	Contour angle	HH	Obstruction height
ADH	Distance to rear ceiling anchor	HT	Obstruction depth
ADM	Distance to central ceiling anchor	LDB	Clear passage width with ThermoFrame (see page 82)
ADV	Distance to ceiling anchor, front	LDH	Clear passage height
B	Start of double radius, factory specification	LH	Track height
DA	Distance to ceiling on request	LZ	Clear frame dimensions (from 1200)
DE	Min. ceiling height	MFR	Space for fitting the door
ER	Top edge corner point	MH	Fitting height
	Track height (depth and height)	OFF	Finished floor level (FFL)
FD	Ceiling clearance	RM	Grid height
FFS	Spring tensioning clearance	STH	Min. headroom
FFW	Spring shaft clearance	WE	Shaft centre from lintel

Please note:

Select required track height according to the door height in Table 4 on page 73.

Note:

- A technical inspection is required!
- The validity tables with the size range shown are based on the standard door type version (see product description). In case of deviations, the valid size ranges in the product configurator must be taken into account.
- The clearance required for fitting the door must be free of supply lines, heater fans, etc.

Notes:

- Observe the permissible size ranges of the door types on pages 10 – 15 and 18 – 35 under all circumstances!
- ALR F42 Vitraplan and ALR F42 Glazing on request.
- To determine the roof slope see page 114.
- Inclination > 10° to 30° on request.

Observe min. sideroom, see page 82.

	WE	FFW	STH	DA	DE
RK 4	315	460 × 850	1477	**	LH + 185
RK 5	335	500 × 850			

B	FFS	FD	FL	ET	ER	MH
**	min. 90° (745)	DA + 65	250	**	**	400

** Dimensions can be found in the product configurator.

All door types in any version on request.

Dimensions in mm

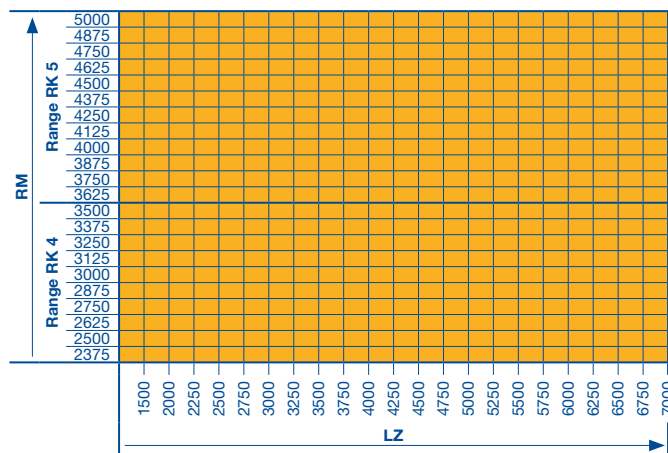

Track Application: V

Vertical track application

Detailed technical data can be found in the product configurator.

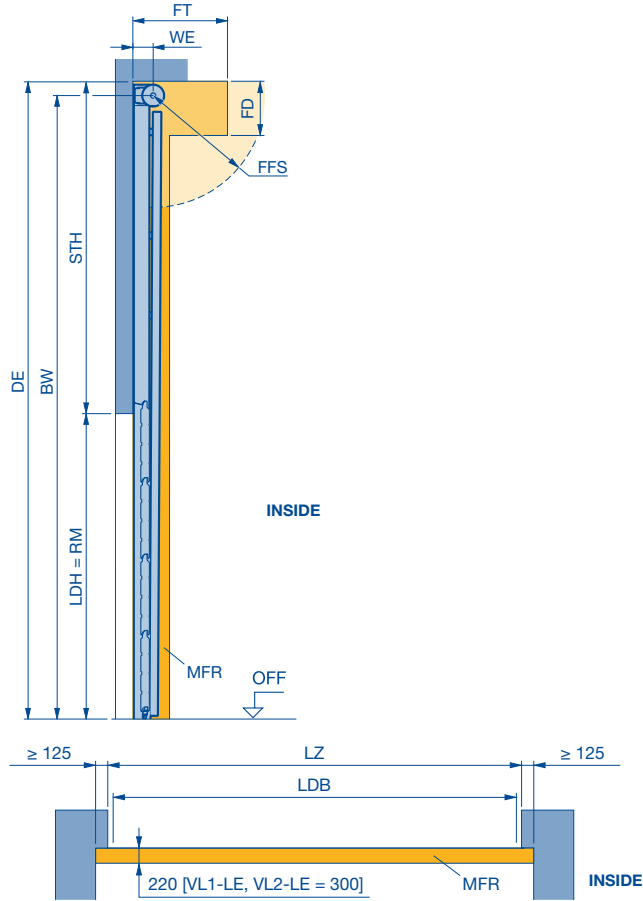

BW	Position of shaft support	LDH	Clear passage height
DE	Min. ceiling height	LZ	Clear frame dimensions (from 1200)
FD	Min. ceiling clearance	MFR	Space for fitting the door
FFS	Spring tensioning clearance	OFF	Finished floor level (FFL)
FT	Clearance for door operation	RM	Grid height
LDB	Clear passage width with ThermoFrame (see page 82)	WE	Shaft centre from lintel
		STH	Min. headroom

Notes:

- The validity tables with the size range shown are based on the standard door type version (see product description). In case of deviations, the valid size ranges in the product configurator must be taken into account.
- The clearance required for fitting the door must be free of supply lines, heater fans, etc.
- Observe the permissible size ranges of the door types on pages 10–15 and 18–35 under all circumstances!
- ALR F42 Vitraplan and ALR F42 Glazing on request

Observe min. sideroom, see page 82.

	STH	WE	DE	BW
V 6	RM + 540	160	2 × RM + 540	2 × RM + 400
V 7	RM + 580 (770*)	180	2 × RM + 580 (770*)	2 × RM + 425
V 9	RM + 675 (820*)	205	2 × RM + 675 (820*)	2 × RM + 475

* with double spring shaft

FD	FFS	FT
500	min 90° (745)	2 × WE

- All door types available in any version.
- Versions with glazing A3, M3, S3, U3, LB, P, XU and / or wicket door as well as versions LZ > 7000 with glazing A3, M3, S3, U3, LB, P on request.
- Doors with wicket door as well as versions with thermo frames and glazing A3, M3, S3, U3, LB, P and XU.
- All door types in any version on request.
- Track limit
- - - Track limit with thermo frames and glazing A3, M3, S3, U3, LB, P, XU and / or wicket door.

Dimensions in mm

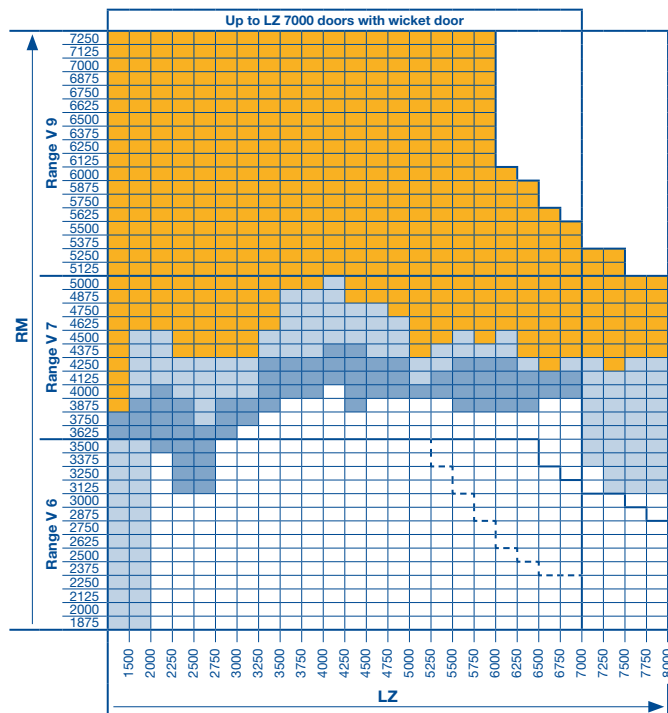

Track Application: VA

Vertical track application

With high-mounted torsion spring shaft

Detailed technical data can be found in the product configurator.

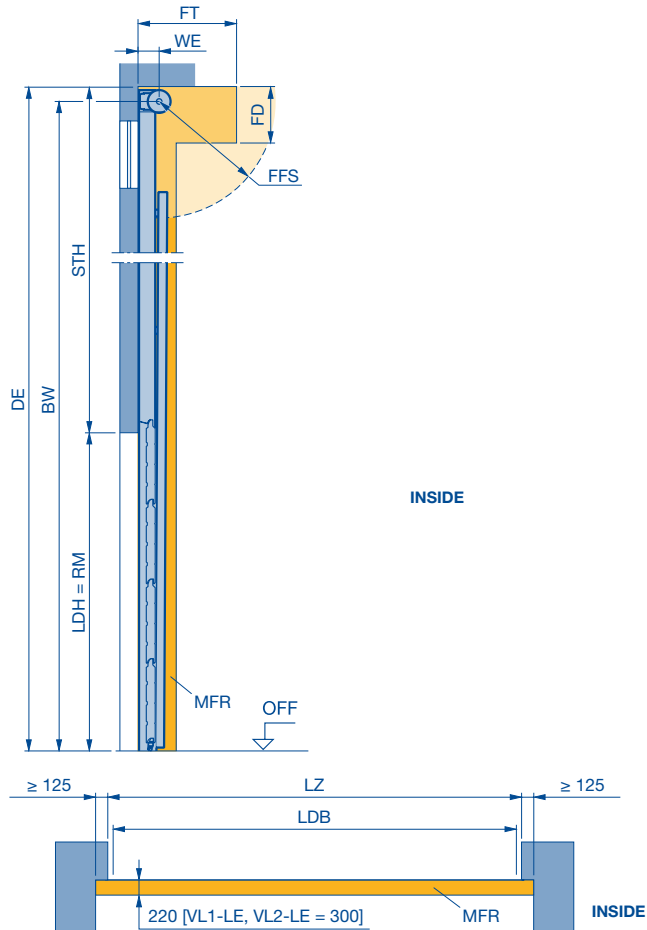

BW	Position of shaft support	LDH	Clear passage height
DE	Min. ceiling height	LZ	Clear frame dimensions (from 1200)
FD	Ceiling clearance	MFR	Space for fitting the door
FFS	Spring tensioning clearance	OFF	Finished floor level (FFL)
FT	Clearance for door operation	RM	Grid height
LDB	Clear passage width with ThermoFrame (see page 82)	STH	Min. headroom
		WE	Shaft centre from lintel

Notes:

- The validity tables with the size range shown are based on the standard door type version (see product description). In case of deviations, the valid size ranges in the product configurator must be taken into account.
- The clearance required for fitting the door must be free of supply lines, heater fans, etc.
- Observe the permissible size ranges of the door types on pages 10 – 15 and 18 – 35 under all circumstances!

Observe min. sideroom, see page 82.

	STH	DE	BW	WE	FD	FFS	FT
VA 6	RM + 550	BW + 140	min. $2 \times RM + 410$ max. DE - 140 (7895)	160	500	min 90° (745)	$2 \times WE$

Note:

ALR F42 Vitraplan and ALR F42 Glazing on request

- All door types available in any version.
- Versions with glazing A3, M3, S3, U3, LB, P, XU and / or wicket door on request.
- Versions with thermo frames and glazing A3, M3, S3, U3, LB, P, XU and wicket door.
- Track limit
- Track limit with thermo frames and glazing A3, M3, S3, U3, LB, P, XU and / or wicket door

Dimensions in mm

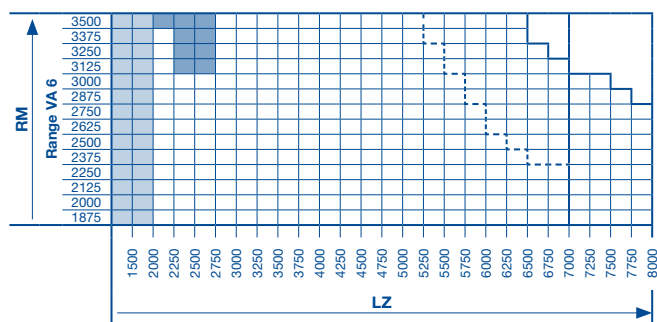

Track application: VS

Vertical track application

With inclination

Detailed technical data can be found in the product configurator.

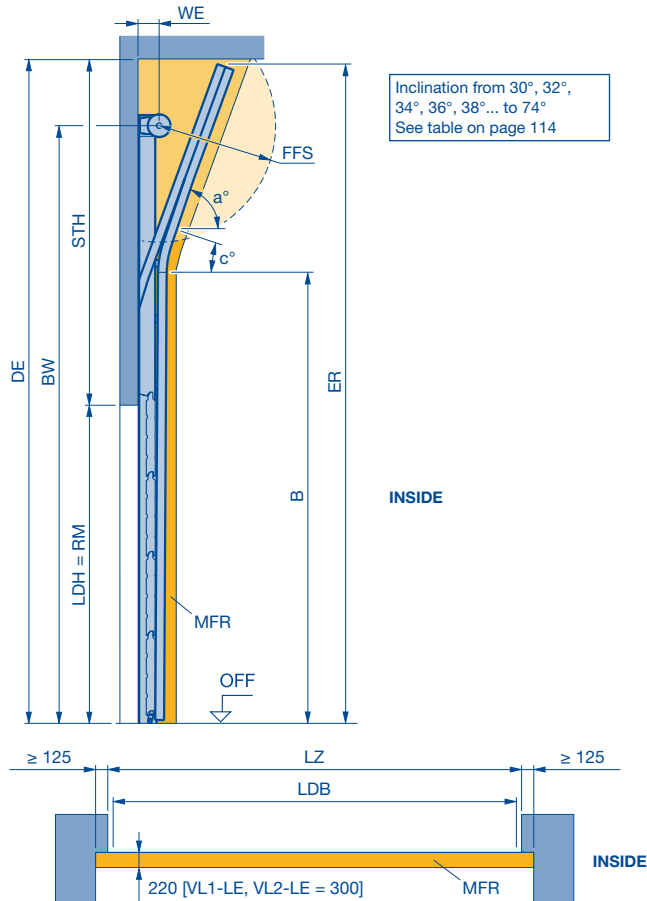

a°	Inclination	LDH	Clear passage height
c°	Contour angle	LZ	Clear frame dimensions (from 1200)
B	Start of double radius	MFR	Space for fitting the door
BW	Position of shaft support	OFF	Finished floor level (FFL)
DE	Min. ceiling height	RM	Grid height
ER	Top edge corner point	STH	Min. headroom
FFS	Spring tensioning clearance	WE	Shaft centre from lintel
LDB	Clear passage width with ThermoFrame (see page 82)		

Notes:

- The validity tables with the size range shown are based on the standard door type version (see product description). In case of deviations, the valid size ranges in the product configurator must be taken into account.
- The clearance required for fitting the door must be free of supply lines, heater fans, etc.
- Observe the permissible size ranges of the door types on pages 10–15 and 18–35 under all circumstances!

Observe min. sideroom, see page 82.

	STH	DE	B	BW	WE	FFS	ER
VS 6	On request	On request	min. RM + 20 max. 2 × RM – 1075	**	160	min 90° (745)	On request
VS 7					180		
VS 9					205		

** Dimensions can be found in the product configurator.

Note:

ALR F42 Vitraplan and ALR F42 Glazing on request

All door types in any version on request.

Track limit

Track limit with thermo frames and glazing A3, M3, S3, U3, LB, P, XU and / or wicket door.

Dimensions in mm

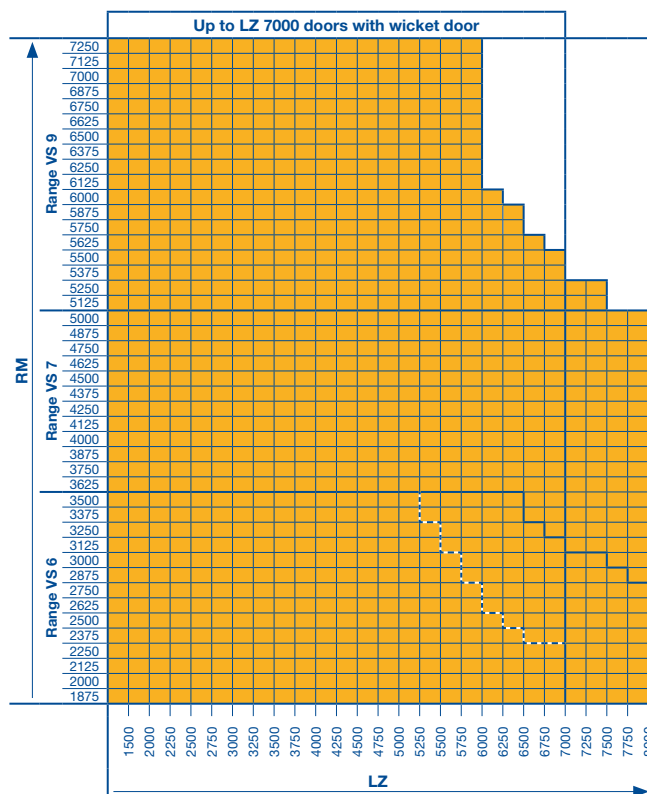

Track Application: VU

Vertical track application with low-mounted torsion spring shaft

Detailed technical data can be found in the product configurator.

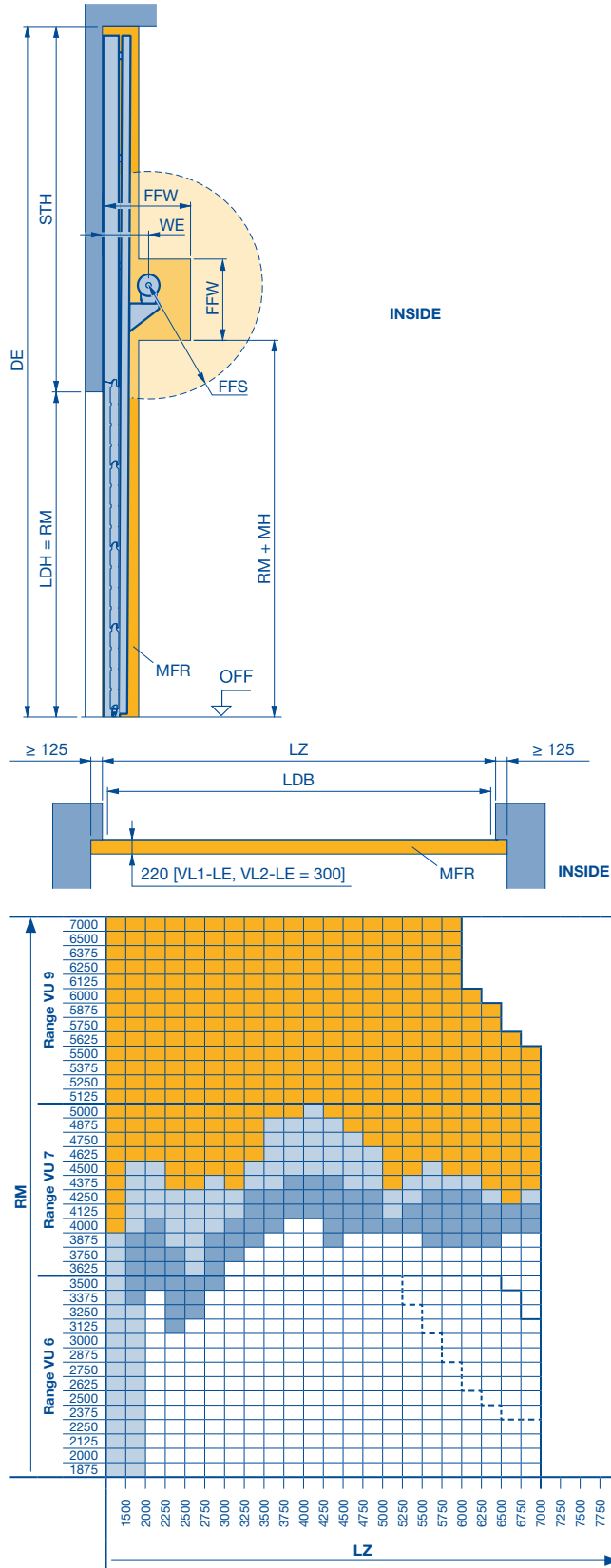

DE	Min. ceiling height	MFR	Space for fitting the door
FFW	Spring shaft clearance	MH	Fitting height
FFS	Spring tensing clearance	OFF	Finished floor level (FFL)
LDB	Clear passage width with ThermoFrame (see page 82)	RM	Grid height
LDH	Clear passage height	STH	Min. headroom
LZ	Clear frame dimensions (from 1200)	WE	Shaft centre from lintel

Notes:

- The validity tables with the size range shown are based on the standard door type version (see product description). In case of deviations, the valid size ranges in the product configurator must be taken into account.
- The clearance required for fitting the door must be free of supply lines, heater fans, etc.
- Observe the permissible size ranges of the door types on pages 10 – 15 and 18 – 35 under all circumstances!

Observe min. sideroom, see page 82.

	STH	DE	WE	FFS	MH	FFW
VU 6			315	min. 90° (745)	400	460 x 850
VU 7	RM+310	STH+RM	335			500 x 850
VU 9			375			580 x 850

Note:

ALR F42 Vitraplan and ALR F42 Glazing on request

- All door types available in any version.
- All door types available, versions with glazing A3, M3, S3, U3, LB, P, XU and / or wicket door on request.
- Door types APU F42 and ALR F42 are possible; APU F42 Thermo, ALR F42 Thermo and SPU F42 with thermo frames as well as versions with glazing A3, M3, S3, U3, LB, P, XU and / or wicket door on request.
- All door types in any version on request.
- Track limit
- Track limit with thermo frames and glazing A3, M3, S3, U3, LB, P, XU and / or wicket door

Dimensions in mm

Track application: WS

Vertical track application

with inclination and low-mounted torsion spring shaft

Detailed technical data can be found in the product configurator.

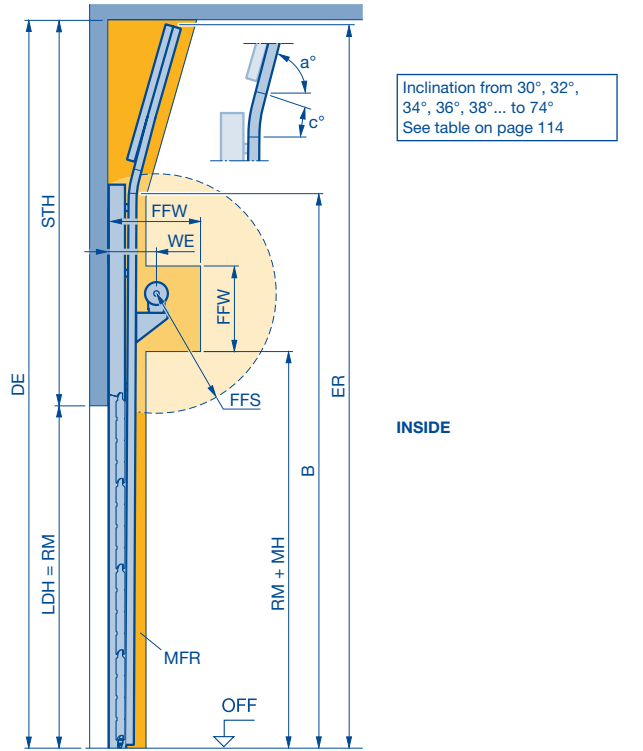

a°	Inclination	LDH	Clear passage height
c°	Contour angle	LZ	Clear frame dimensions (from 1200)
B	Start of double radius	MFR	Space for fitting the door
DE	Min. ceiling height	MH	Fitting height 400
ER	Top edge corner point Track height (depth and height)	OFF	Finished floor level (FFL)
FD	Ceiling clearance	RM	Grid height
FFW	Spring shaft clearance	STH	Min. headroom
FFS	Spring tensioning clearance	WE	Shaft centre from lintel
LDB	Clear passage width with ThermoFrame (see page 82)		

Notes:

- The validity tables with the size range shown are based on the standard door type version (see product description). In case of deviations, the valid size ranges in the product configurator must be taken into account.
- The clearance required for fitting the door must be free of supply lines, heater fans, etc.
- Observe the permissible size ranges of the door types on pages 10–15 and 18–35 under all circumstances!

Observe min. sideroom, see page 82.

	WE	FFW	FFS	MH
WS 6	315	460 × 850	min. 90° (745)	400
WS 7	335	500 × 850		
WS 9	375	580 × 850		

B	DE	ER	STH
min. RM + 1200 max. 2 × RM – 1000	On request	On request	On request

Note:

ALR F42 Vitraplan and ALR F42 Glazing on request

All door types in any version on request.

Track limit

Track limit with thermo frames and glazing A3, M3, S3, U3, LB, P, XU and / or wicket door

Dimensions in mm

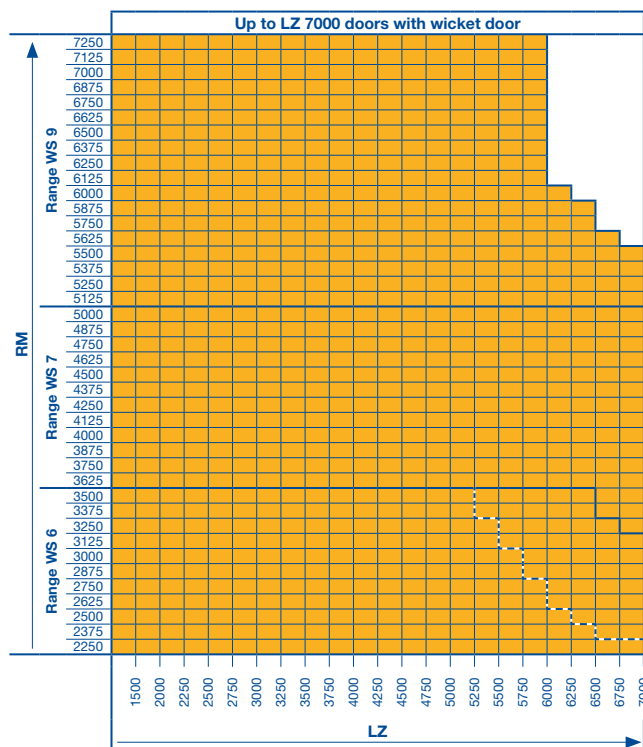
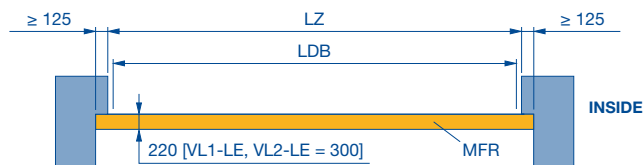

Sideroom

Required sideroom

Track application / designation	SA	Track application / designation	SA
N, NA, ND, NH, NS, NK, GD, V, VA, VU, GK, GS, VS, WS	125	Hand pulley	N, NA, ND, NH, NS, GD, NK, GS, GK
H, HA, HD, HU, RD, HK, HS, RS, RK	150		H, HA, HD, HU, RD, HK, HS, RS, RK
L, LD	125		V, VA, VU, VS, WS
With use of the C-rail (page 88 – 89)	170	Hand chain for emergency operation for operator doors	140
		Chain hoist	Page 86
		Shaft operators	Page 91 – 99

Sideroom

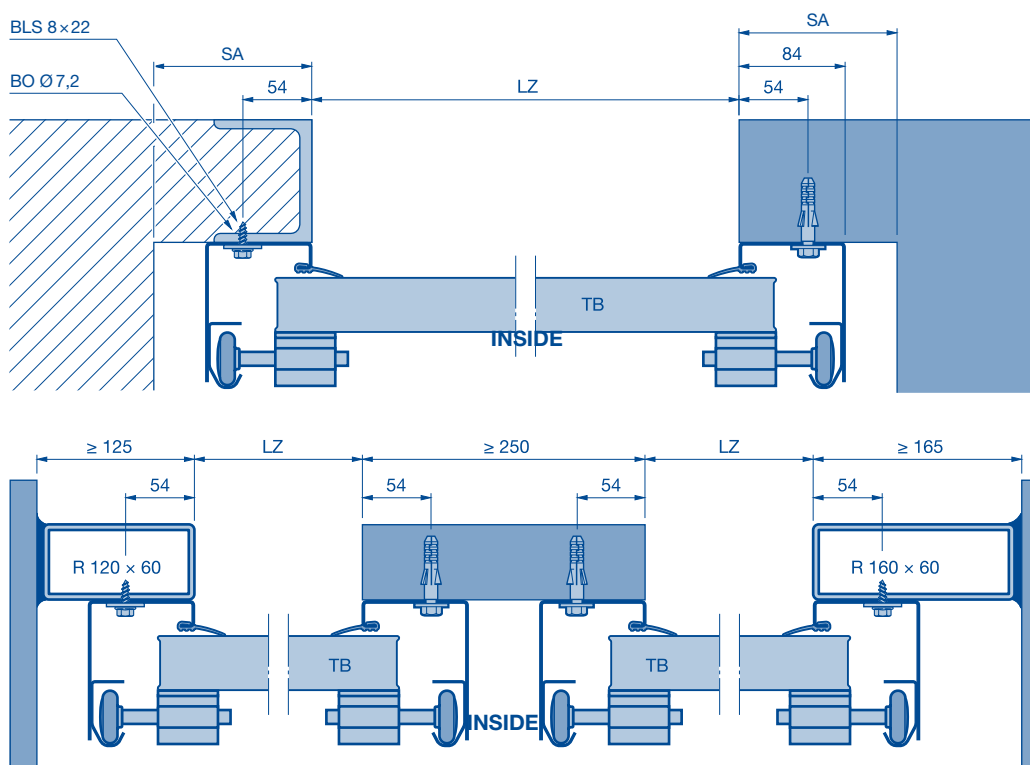

Sideroom with frame covering

ThermoFrame version

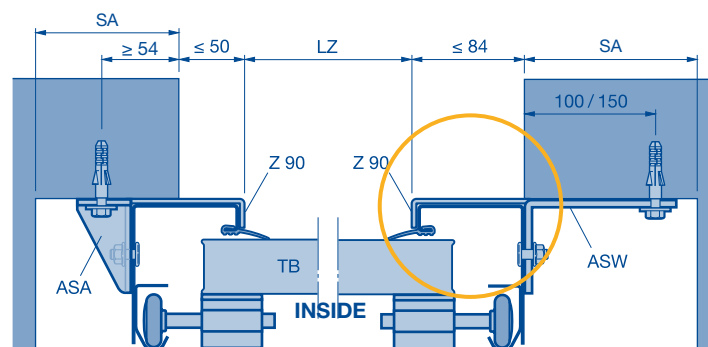
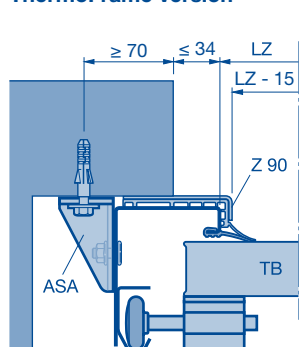

ThermoFrame version

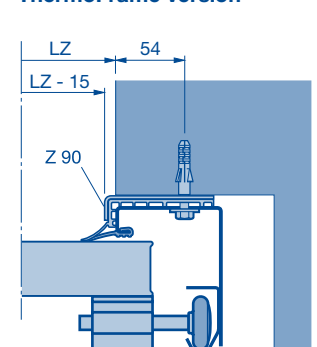

Note:
Clear door frame in the opening is not possible for the RC2 version.

ASA Screw-on anchor 70 × 40
ASW Screw-on bracket 70 × 120 / 170
BO Hole
BOS drilling screw

BLS Self-tapping screw
LZ Clear frame dimension
R Box section
SA Sideroom

TB Door leaf
Z Frame covering

Sideroom

ThermoFrame sideroom 6 mm

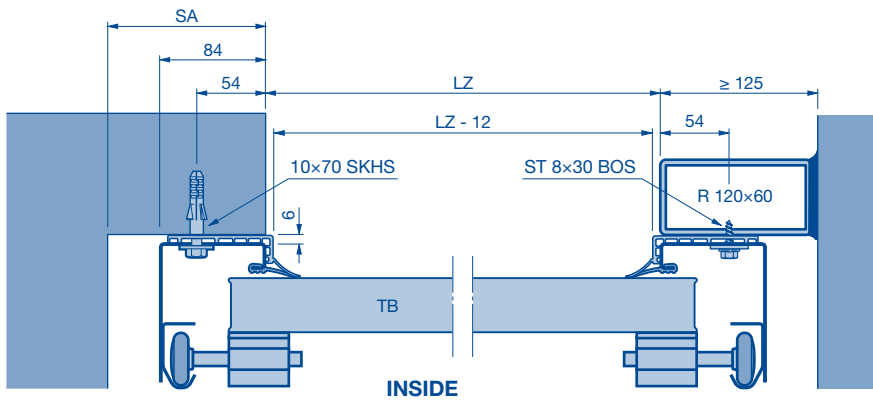

ThermoFrame sideroom 26 mm with lintel counter seal

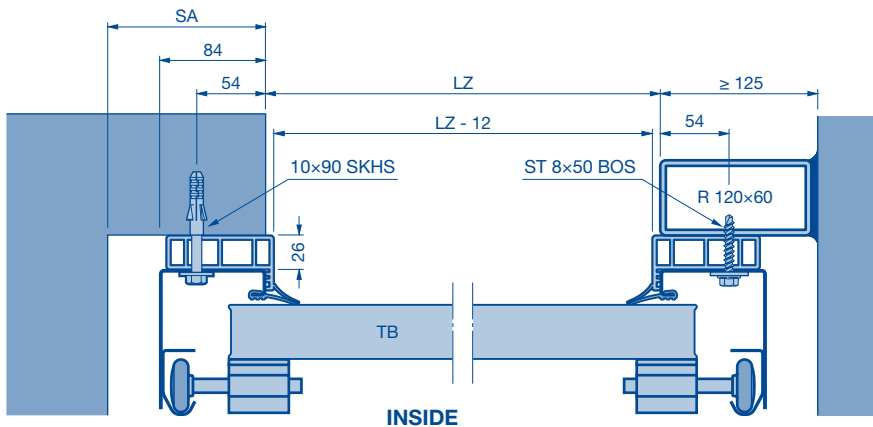

Fitting to brickwork

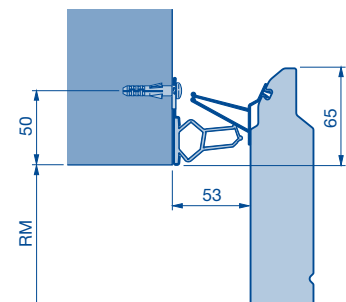

Tube fitting (120, 160, 200)

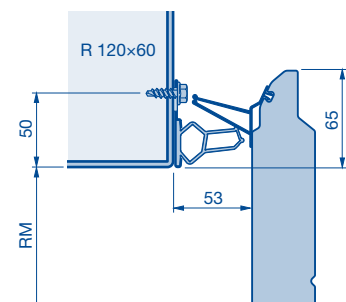

Note:

Door versions with facade door, panels or frame covering as well as frame fitting with screw-on bracket are not possible.

BOS	drilling screw	SA	Sideroom
LZ	Clear frame dimension	SKHS	Hexagon woodscrew
R	Box section	TB	Door leaf
RM	Standard size		

Lintel fittings

Normal lintel fitting
Insufficient headroom up to 30 mm high

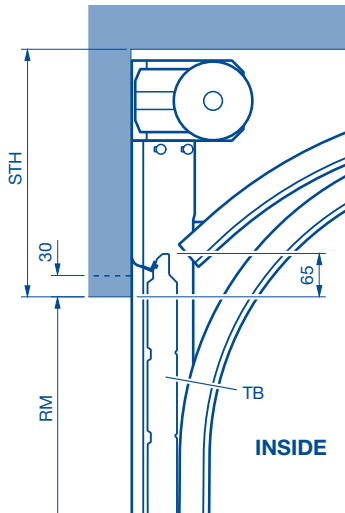

Normal lintel fitting
Double spring shaft

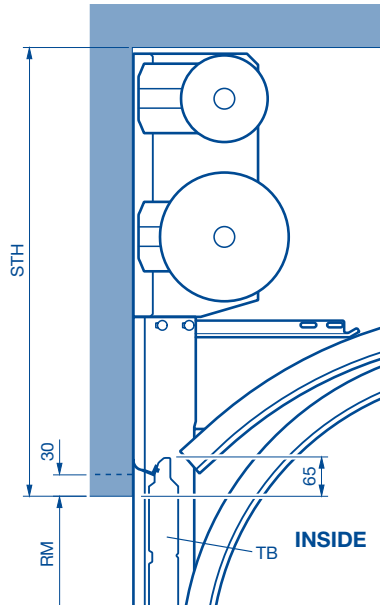

Single-skinned steel fascia for SPU F42 to make up for insufficient headroom up to 125 mm
(only for track applications N and L)

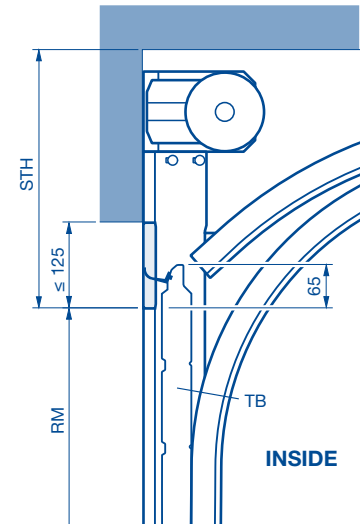

Smooth panel, anodised, for APU F42, ALR F42, ALR F42 Glazing, ALR F42 Vitraplan to make up for insufficient headroom from 31 to 190 mm height and LZ ≤ 7000 mm (only for track application N and L)

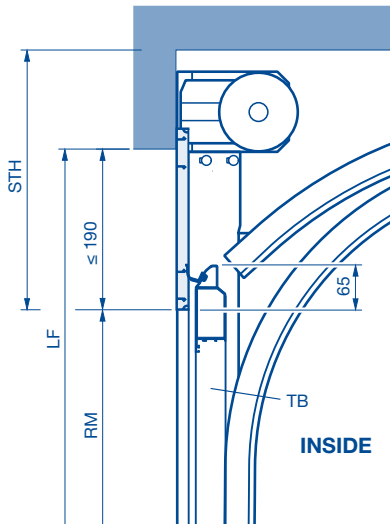

PU fascia panel to make up for insufficient headroom from 100 mm
Aluminium fascia panel to make up for insufficient headroom (see table)

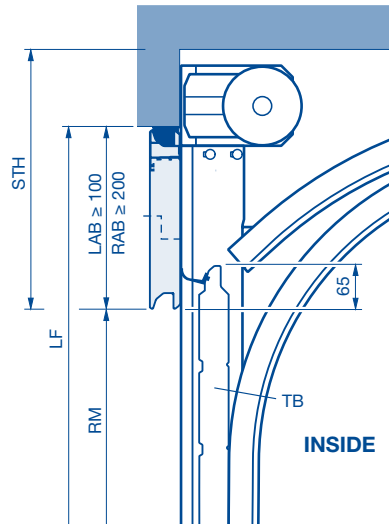

Fitting clearance for multiple-point locking

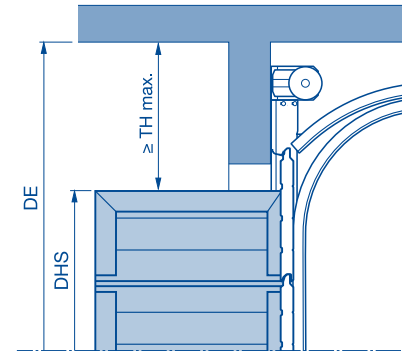

Lintel fitting with ThermoFrame

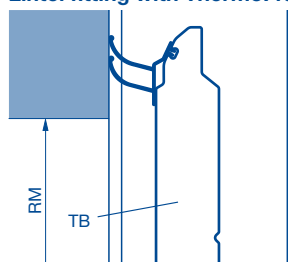

Aluminium fascia panels	
Height	Infill type
≥ 200	FU, LB, S, SE, XU, FK, KR
≥ 245	S2, S3, U2, U3, C2, A2, A3, M2, M3

- Aluminium frame fascia panel with real glass infill VG, E2 and G2 on request.

- DE Ceiling height
- DHS Clear passage height of wicket door
- RAB Frame fascia panel
- LF Structural opening
- LAB Fascia panel
- RM Standard size
- STH Min. headroom (see page 56)
- TB Door leaf

Bottom edge

Without wicket door / with wicket door and threshold rail

with wicket door with trip-free threshold

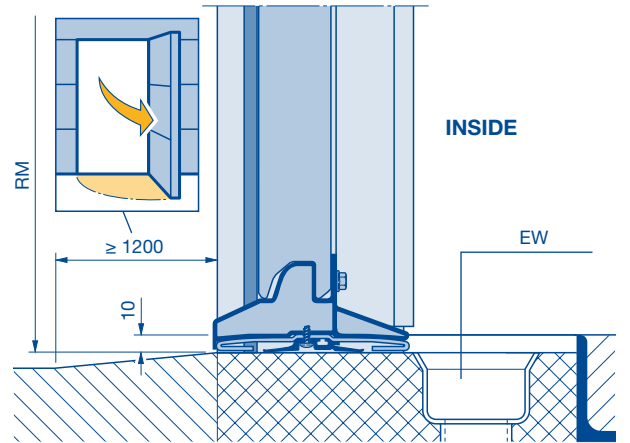
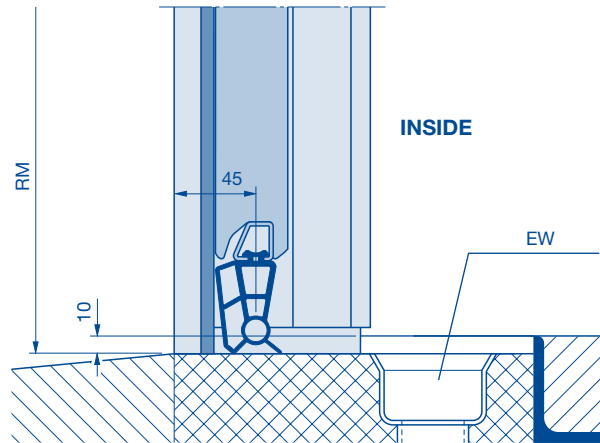
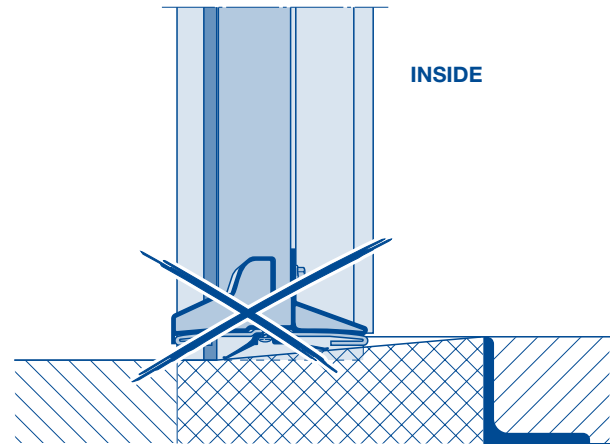
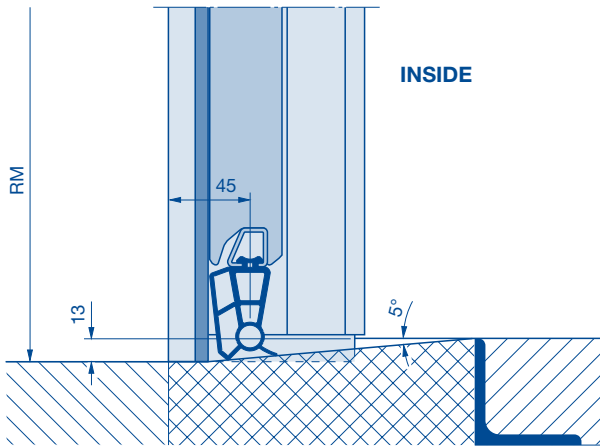

Adjustable bottom profile

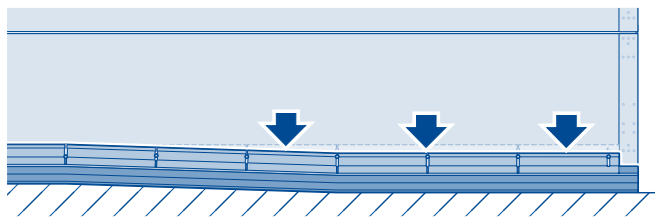

Height difference min. 0 mm / max. 20 mm

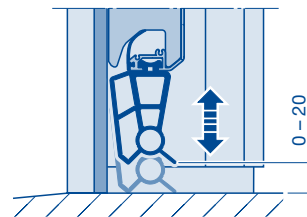

Chamfered bottom edge

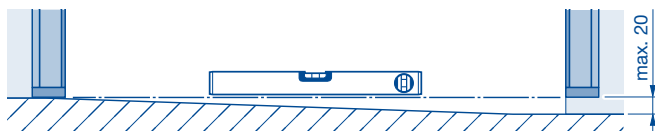

Bottom edge following the contour

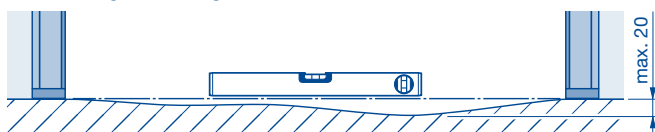

Notes:

- Version with door with wicket door, shortened bottom door section and bottom glazing frame not possible!
- Not possible for fixed elements, Parcel sectional door and doors for lowered section for dock leveller!
- Restriction of the passage height up to 20 mm possible!

EW Drainage
RM Standard size

Chain hoist

Chain hoist for all track applications except HU, RD, RS, RK, VU, WS

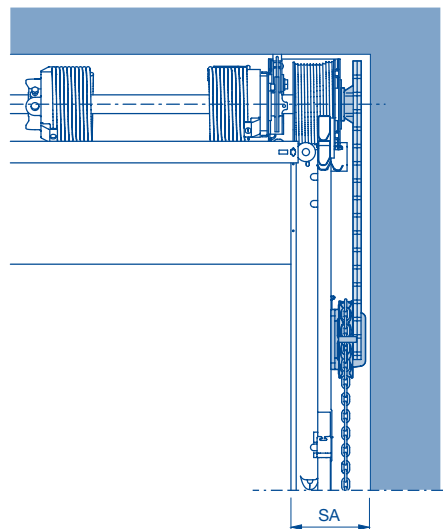
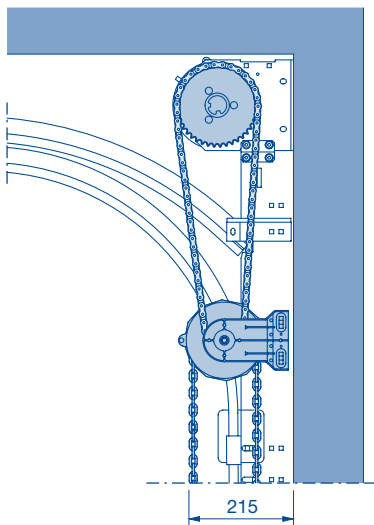

Track application	N, NA, ND, NS, NK	NH, GD, GS, GK	L, LD	H, HA, HD, HS, HK	V, VA, VS
SA	165	165	165	185	165

Chain hoist for track applications HU, RD, RS, RK, VU, WS

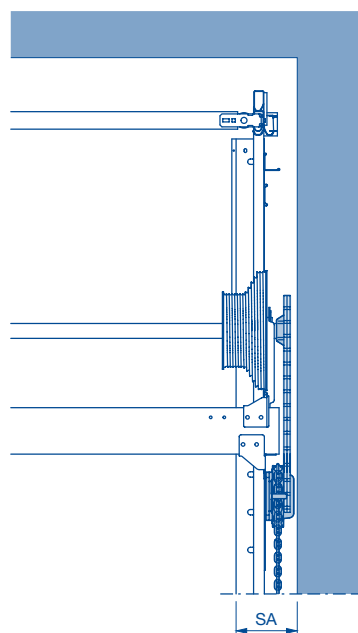
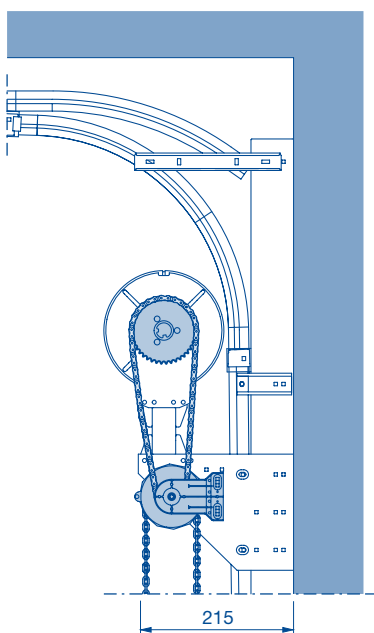

Track application	HU, RD, RS, RK	VU, WS
SA	185	185

SA Sideroom

Hand pulley

With rope or link steel chain

Track applications up to 20 m² door surface

With rope or link steel chain

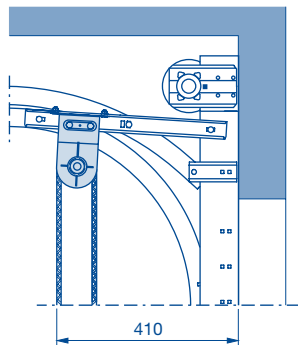

N, NA, ND, NH, NS, GD, H, HA, HD, HU, RD

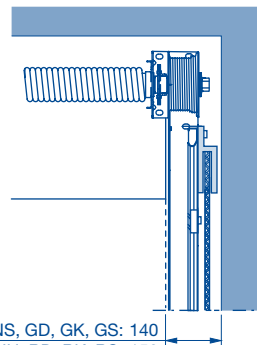

N, NA, ND, NH, NK, NS, GD, GK, GS: 140
H, HA, HD, HK, HS, HU, RD, RK, RS: 150

With rope or link steel chain

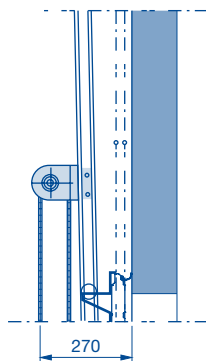

V, VA, VS

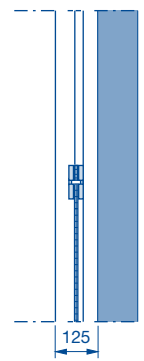

With rope or link steel chain

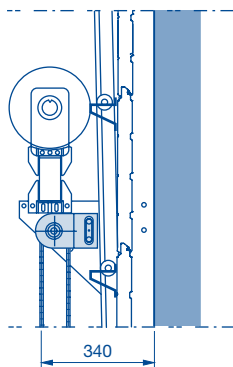

VU, WS

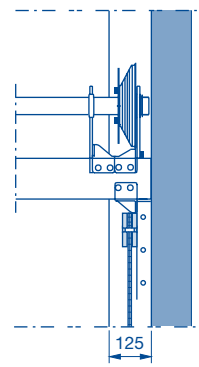

Ceiling anchor

Double track

Track suspensions for all track applications except V, VA, VU

Door weights for roof loads (see pages 56 – 67).

Double track (suspensions), door heights $RM \leq 5000$

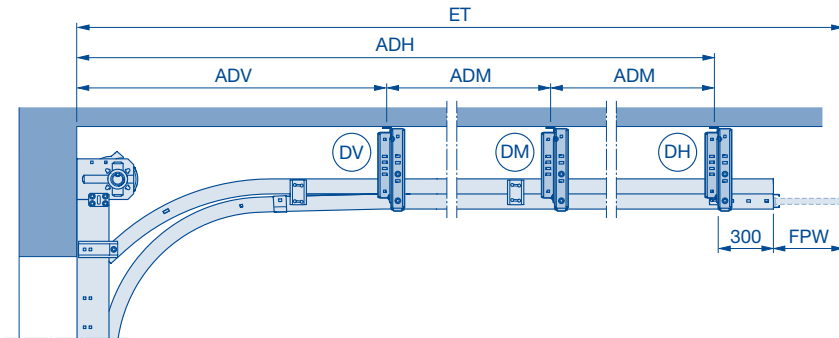

Notes:

- Detailed technical data can be found in the product configurator.
- On-site fastening elements must be able to withstand forces of up to 1.5 kN per fixing point!
- Always obtain the permission of the structural engineer before fastening the door system to supporting structural elements.
- Deviations may occur due to the simplified calculation of the distance back. Detailed technical data can be found in the product configurator.

Double track (suspensions) for track application L

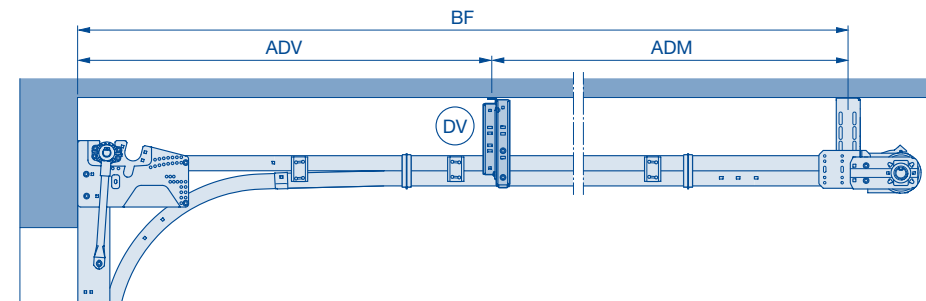

Track suspensions with double track

Track application	LZ	ET	Number of suspensions per side	DV	DM	DH / BF	ADV	ADM	ADH / BF	FPW
N, NA	≤ 7000	2264–3910	2	1	0	1	1400	–	ET - 597 ET - 327	Long Short
		3911–5660	3	1	1	1	1400	$(ET - ADV - 597) / 2$ $(ET - ADV - 327) / 2$	ET - 597 ET - 327	Long Short
	> 7000	2264–2910	2	1	0	1	1400	–	ET - 597 ET - 327	Long Short
		2911–4035	3	1	1	1	1400	$(ET - ADV - 597) / 2$ $(ET - ADV - 327) / 2$	ET - 597 ET - 327	Long Short
		4036–5660	4	1	2	1	1400	$(ET - ADV - 597) / 3$ $(ET - ADV - 327) / 3$	ET - 597 ET - 327	Long Short
			L	≤ 7000	2857–3516	2	1	0	1	1400
3517–5641	3	1	1		1	1400	$(BF - ADV) / 2$			
5642–5982	4	1	2		1	1400	$(BF - ADV) / 3$			
H, HA, HU	≤ 7000	1890–2177	1	0	0	1	–	–	ET - 597 ET - 327	Long Short
		2178–3957	2	1	0	1	1400	–	ET - 597 ET - 327	Long Short
		3958–5464	3	1	1	1	1400	$(ET - ADV - 597) / 2$ $(ET - ADV - 327) / 2$	ET - 597 ET - 327	Long Short
		5465–5694	4	1	2	1	1400	$(ET - ADV - 327) / 3$	ET - 327	Short
	> 7000	1890–2177	1	0	0	1	1400	–	ET - 597 ET - 327	Long Short
		2178–2967	2	1	0	1	1400	–	ET - 597 ET - 327	Long Short
		2968–3839	3	1	1	1	1400	$(ET - ADV - 597) / 2$ $(ET - ADV - 327) / 2$	ET - 597 ET - 327	Long Short
		3840–5194	4	1	2	1	1400	$(ET - ADV - 597) / 3$ $(ET - ADV - 327) / 3$	ET - 597 ET - 327	Long Short
NH, ND, GD, LD, HD, RD, VS, WS	Dimensions can be found in the product configurator									

ADH Distance to rear ceiling anchor
ADM Distance to central ceiling anchor
ADV Distance to ceiling anchor, front
BF Position of spring shaft
DA Distance to ceiling

DAL Ceiling anchor length
DH Rear ceiling anchor
DM Centre ceiling anchor
DV Ceiling anchor front
ET Min. distance back

FPW Spring buffer travel
LZ Clear frame dimension

Ceiling anchor

C-rail

C-rail (suspensions) all track sizes except NS, NK, GS, GK, V, VA

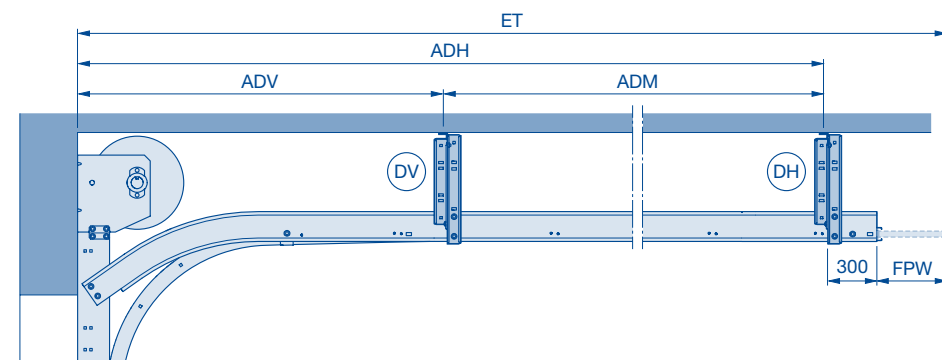

Note:
Deviations may occur due to the simplified calculation of the distance back. Detailed technical data can be found in the product configurator.

All door types RM > 4500 and LZ > 6250, all door types RM > 5000 except for track application L / LD doors with real glass RM > 3500 and LZ > 5000

Track application	LZ	ET	Number of suspensions per side	DV	DM	DH/BF	ADV	ADM	ADH/BF	FPW
N, NA	≤ 8000	≤ 6660	2	1	0	1	ADH/2	-	ET - 597	Long
		> 6660	3	1	1	1	ADH/3	(ET - ADV - 597) / 2	ET - 597	Long
L	≤ 7000	≤ 5982	2	1	0	1	BF/2	-	RM + 670	-
H, HA, HU	≤ 8000	≤ 6714	2	1	0	1	ADH/2	-	ET - 597	Long
		> 6714	3	1	1	1	ADH/3	(ET - ADV - 597) / 2	ET - 327	Short
NH, ND, GD, LD, HD, RD, VS, WS	Dimensions can be found in the product configurator									

Use of C-rail to reduce suspensions

Track application	LZ	ET	Number of suspensions per side	DV	DM	DH/BF	ADV	ADM	ADH/BF	FPW
N, NA		≤ 3785	1	0	0	1	-	-	ET - 597	Long
		> 3785	2	1	0	1	ADH/2	-	ET - 327	Short
L	≤ 5500	≤ 3516	1	0	0	1	-	-	-	-
		3517-5891	2	1	0	1	BF/2	-	RM + 670	-
H, HA, HU		≤ 5891	3	1	1	1	BF/3	(BF - ADV) / 2	RM + 670	-
		≤ 3715	1	0	0	1	-	-	ET - 597	Long
H, HA, HU		> 3715	2	1	0	1	ADH/2	-	ET - 327	Short
		> 3715	2	1	0	1	ADH/2	-	ET - 597	Long
NH, ND, GD, LD, HD, RD, VS, WS	Dimensions can be found in the product configurator									

Track suspensions for distance to ceiling in seven lengths, standard length for DA = 375 mm

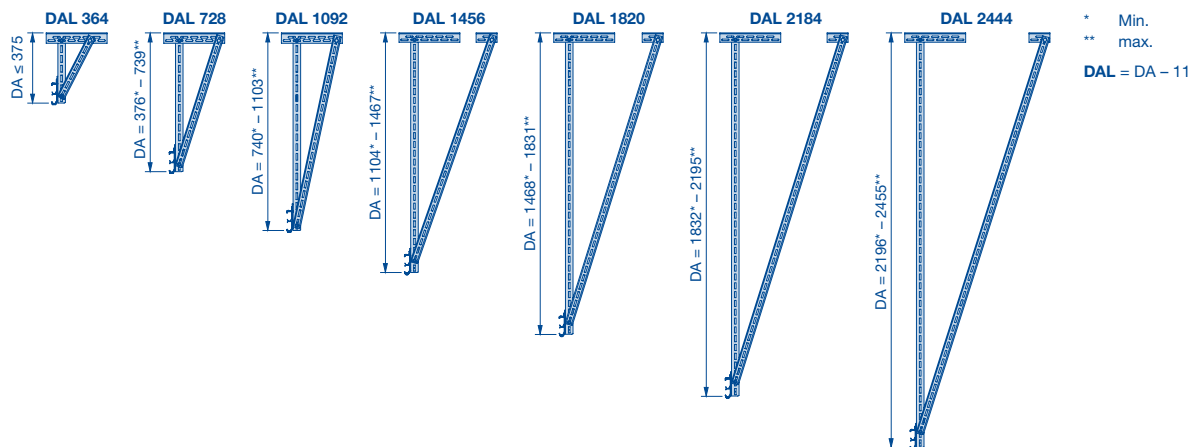

* Min.
** max.
DAL = DA - 11

ADH	Distance to rear ceiling anchor	DAL	Ceiling anchor length	FPW	Spring buffer travel
ADM	Distance to central ceiling anchor	DH	Rear ceiling anchor	LZ	Clear frame dimension
ADV	Distance to ceiling anchor, front (max. 3000)	DM	Centre ceiling anchor		
BF	Position of spring shaft	DV	Ceiling anchor front		
DA	Distance to ceiling	ET	Min. distance back		

Diagonal strut

Detailed technical data can be found in the product configurator. Deviations may occur due to the simplified calculation of the distance back.

Please note:

A technical inspection is required!

Notes:

- Application range of $LZ \leq 3000$ and $RM \leq 3250$
- Distance back max. 2297
- Not for door type ALR F42 Glazing.

Track application H

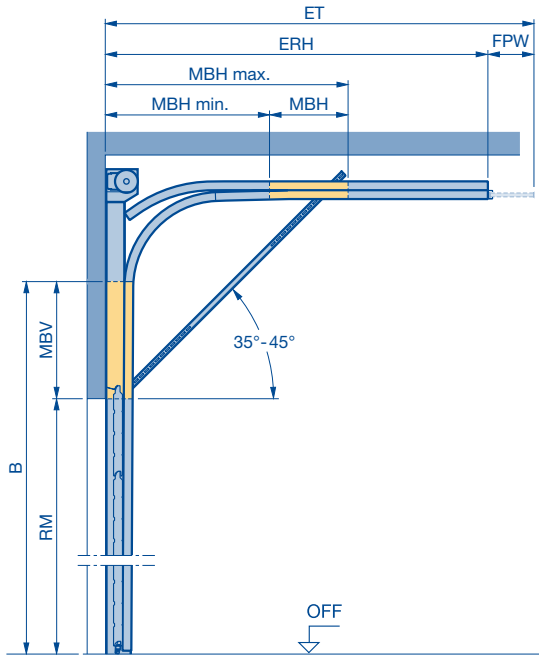

Other required technical data for track application H must be observed (see page 68).

Track application HU

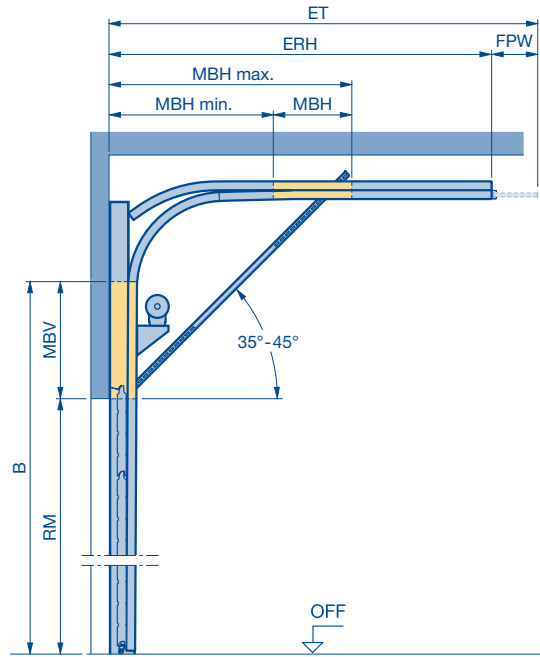

Other required technical data for track application HU must be observed (see page 73).

ET	ERH	MBH min.	MBH max.	FPW*		MBH	MBV		
				Min.	max.		Track application H	Track application HU	
Max. 2297	ET - FPW (max. 2000)	ERH / 2	$3 \times ERH / 4$	27	297	MBH max. - MBH min.	RM	B	
							MBH min.	MBH max.	
									On request

* Dimensions can be found in the product configurator.

Connection door - door

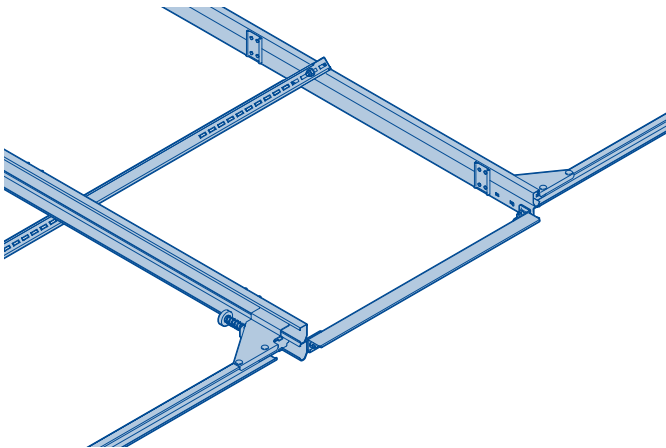

Connection door - wall

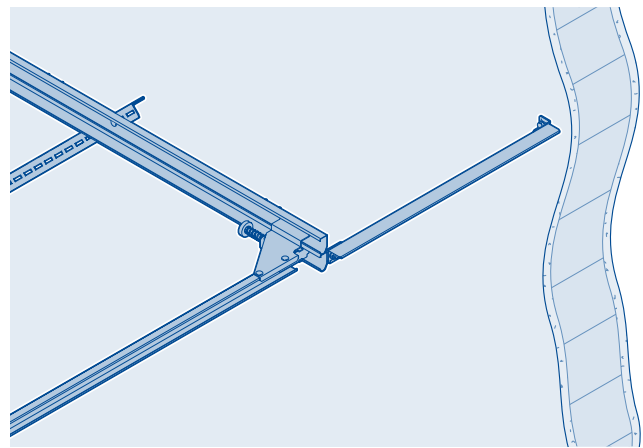

B Start of double radius
ET Min. distance back
ERH Corner point track horizontal

FPW Spring buffer travel
MBH Fitting area horizontal
MBV Fitting area vertical

OFF Finished floor level (FFL)
RM Grid height

Shaft operator WA 300

Shaft operator WA 300 for track applications N, NA, ND, NS, NH, NK, GD, GS, GK, H, HA, HD, HS, HK, V, VA and VS

As shown in the figure, the operator can be fitted either left or right, viewed from the inside.

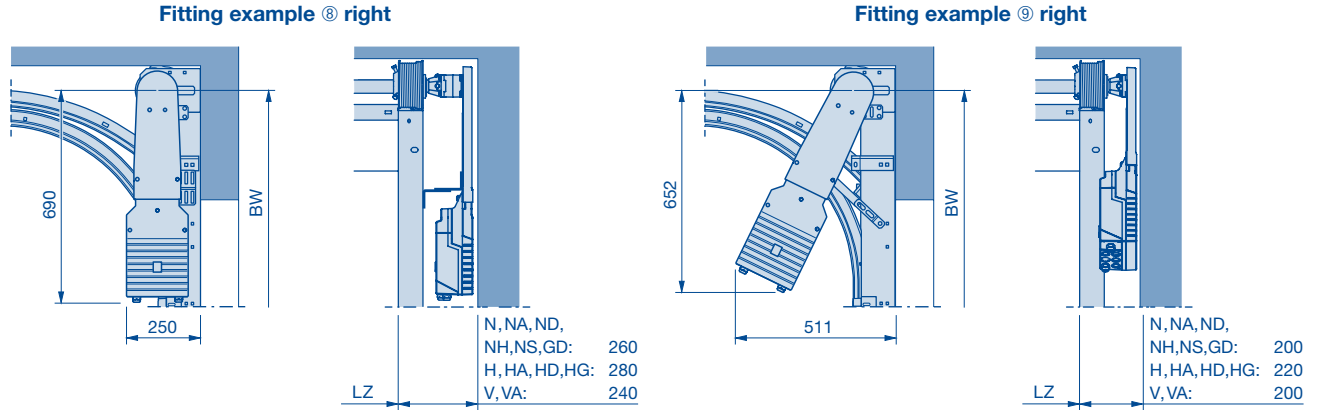

Shaft operator WA 300 for track applications HU, RD, RS, RK, VU and WS

As shown in the figure, the operator can be fitted either left or right, viewed from the inside.

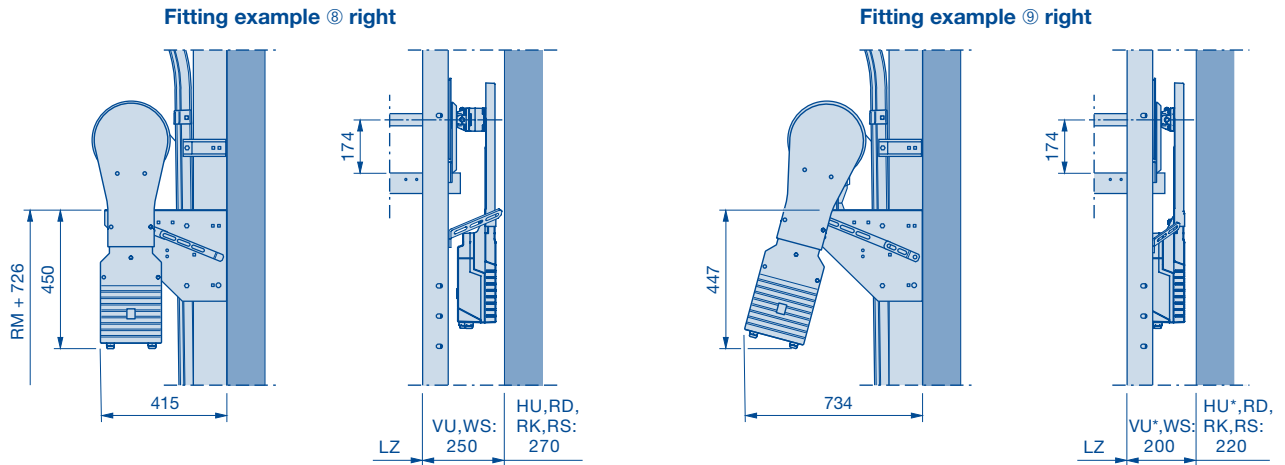

*** Note:**

In the door range $LZ \leq 3000$ and $RM \leq 3500$ the track applications VU and HU are not possible

BW Position of shaft support
LZ Clear frame dimension

STH Min. headroom
RM Grid height

Shaft operator WA 300

Shaft operator WA 300 for track applications L and LD

As shown in the figure, the operator can be fitted either left or right, viewed from the inside. **In fitting example 9: on the side opposite the door lock.**

Fitting example 8 right

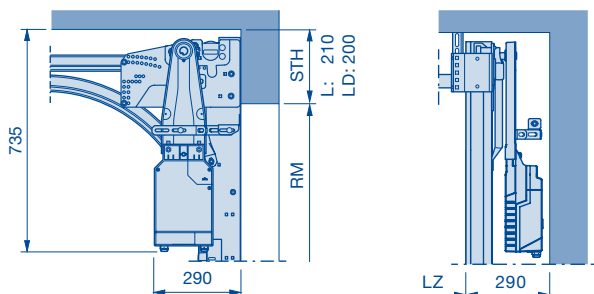

Fitting example 9 right

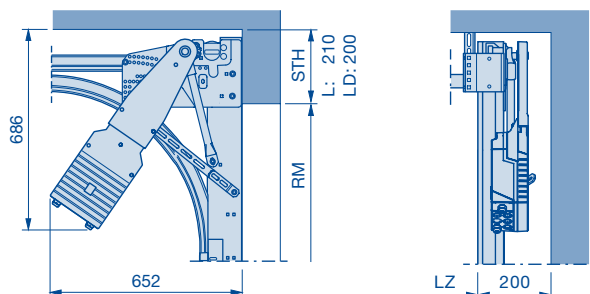

Fitting example 8 right with swivel mechanism

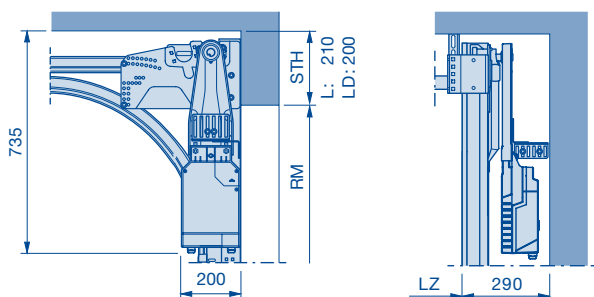

Fitting example 9 right with swivel mechanism

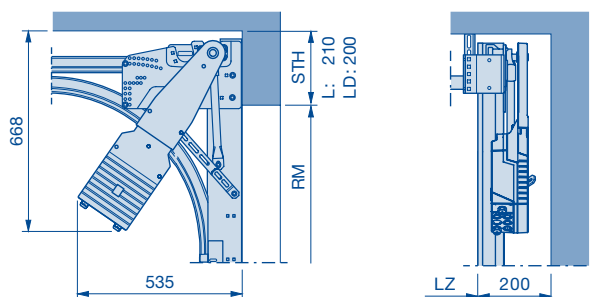

LZ Clear frame dimension
STH Min. headroom
RM Grid height

Shaft operator WA 300

Size range WA 300 (ALR F42 Vitraplan on request)

Track applications: N, NA and NH

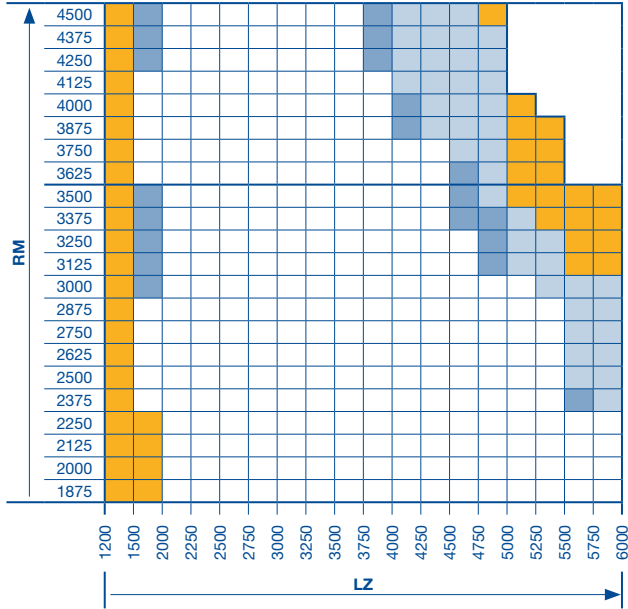

Track applications: ND and GD

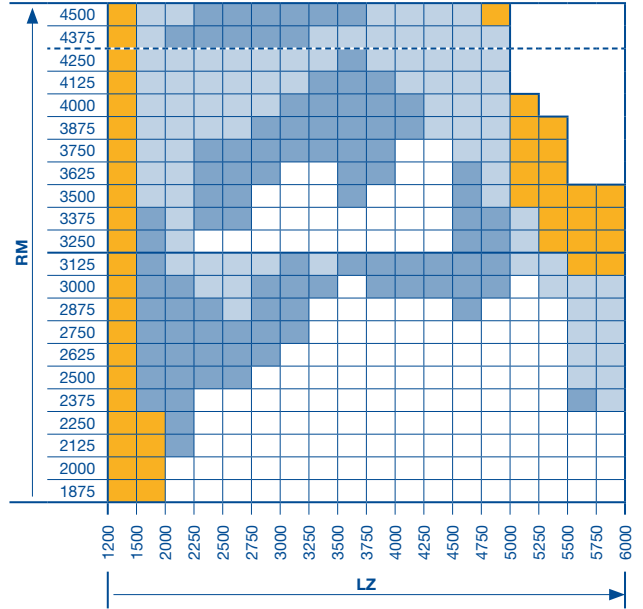

Track application: L

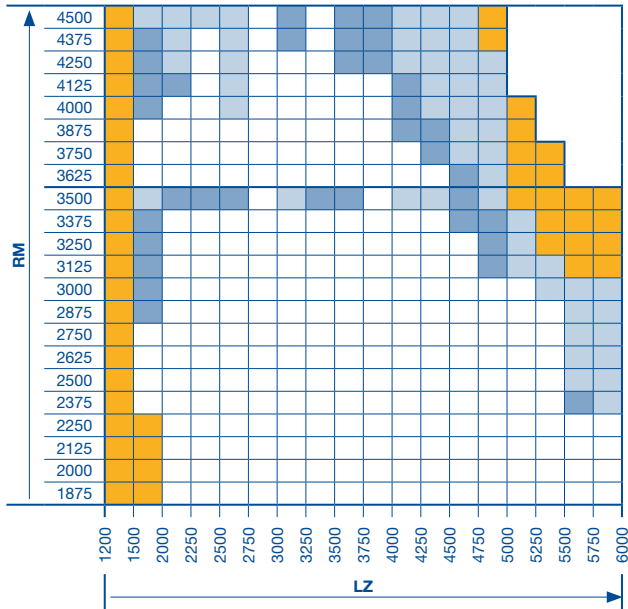

Track Application: LD

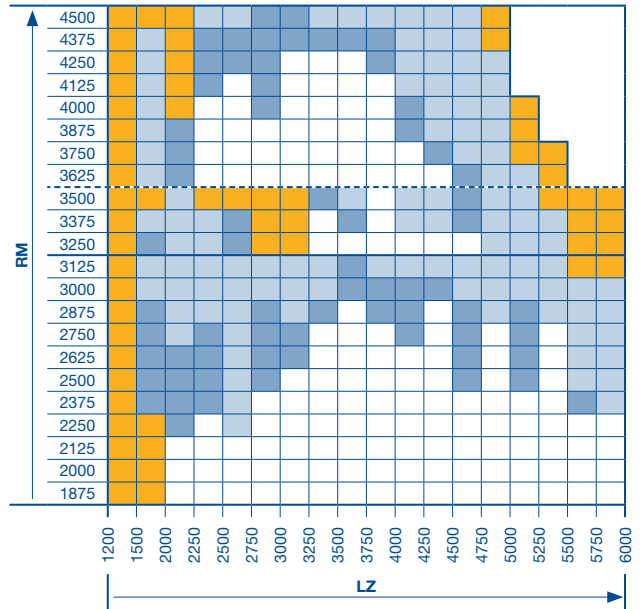

- All door types available in any version.
- All door types with thermo frames, glazing A3, M3, S3, U3, LB, P, XU or wicket door on request.
- All door types with thermo frames, glazing A3, M3, S3, U3, LB, P, XU and / or wicket door on request.
- All door types in any version on request.

Note:
Track application NS on request!

LZ Clear frame dimension
RM Grid height

Dimensions in mm

Shaft operator WA 300

Size range WA 300 (ALR F42 Vitraplan on request)

Track application: H, HA and HU

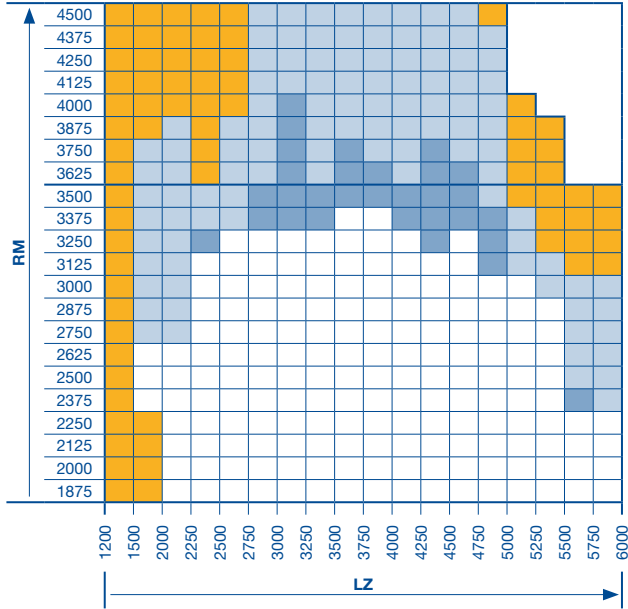

Track application: HD and RD

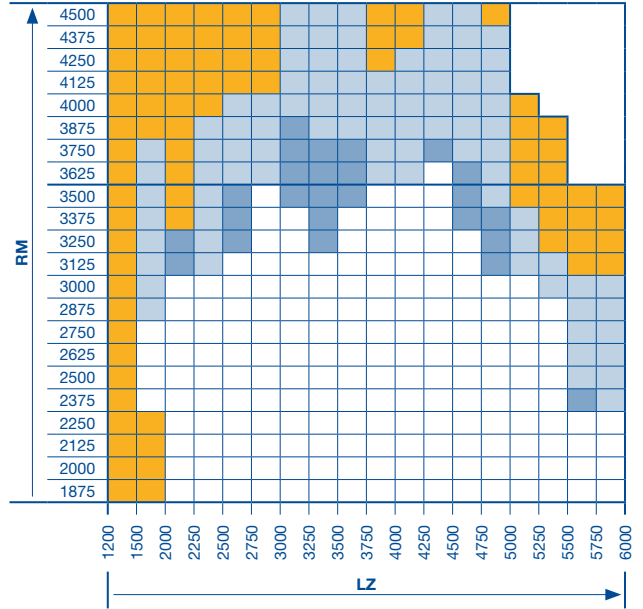

Track application: V and VA

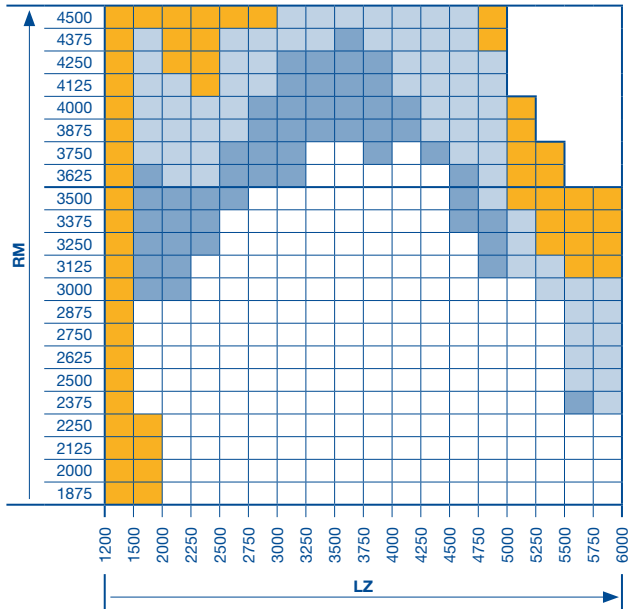

Track Application: VU

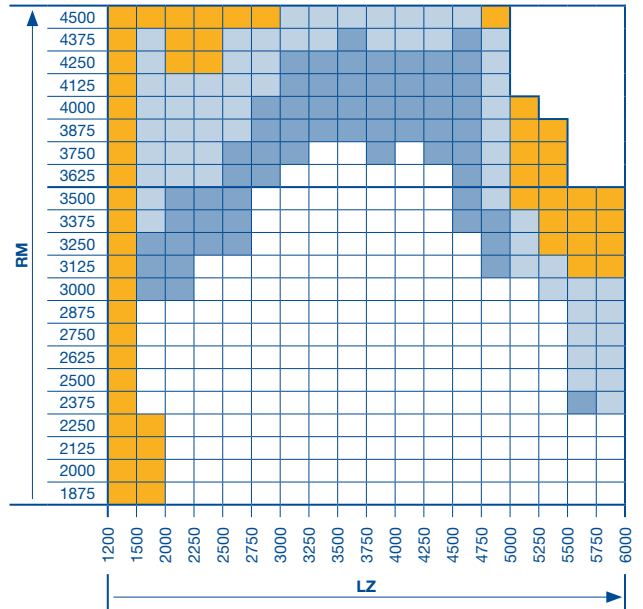

- All door types available in any version.
- All door types with thermo frames, glazing A3, M3, S3, U3, LB, P, XU or wicket door on request.
- All door types with thermo frames, glazing A3, M3, S3, U3, LB, P, XU and / or wicket door on request.
- All door types in any version on request.

LZ Clear frame dimension
RM Grid height

Dimensions in mm

Shaft operator WA 500 / 500 FU

As a frame-mounted operator

Shaft operator WA 500 / WA 500 FU for all track applications, except L, LD, HU, RD, RS, RK, VU and WS

As shown in the figure, the operator can be fitted either left or right, viewed from the inside.

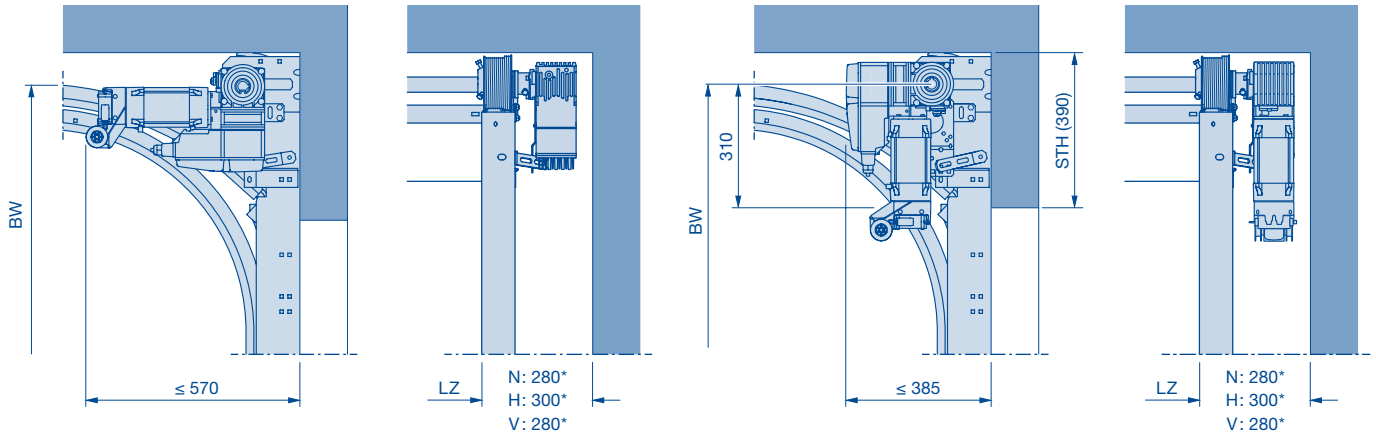

*** Note:**

Dimension + 75 mm if using a non-jointed emergency crank handle

Shaft operator WA 500 / WA 500 FU for track applications HU, RD, RS, RK, VU and WS

As shown in the figure, the operator can be fitted either left or right, viewed from the inside.

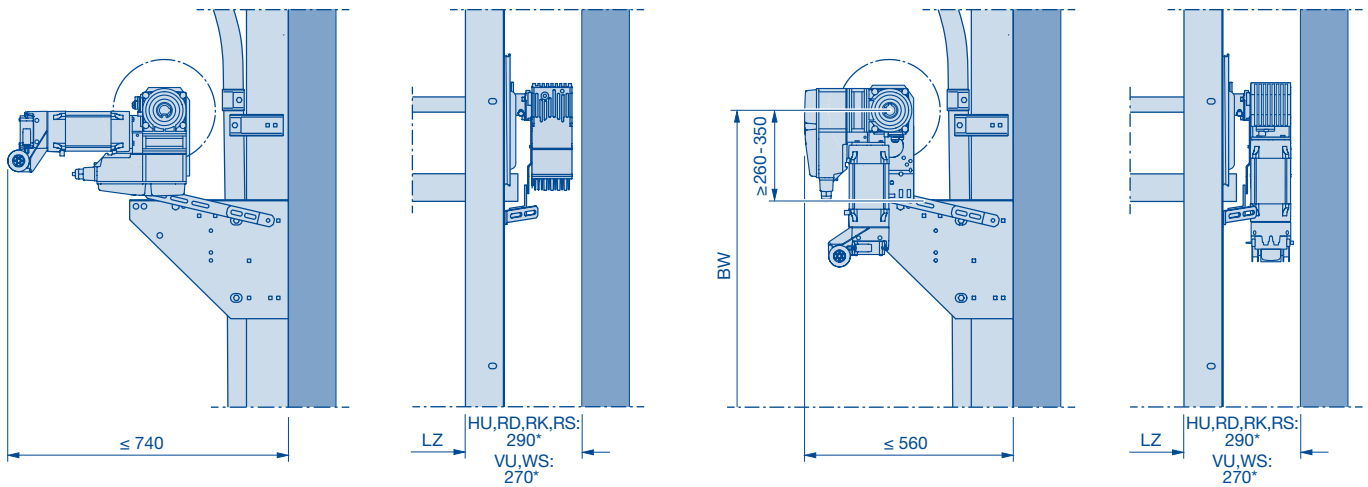

*** Note:**

Dimension + 75 mm if using a non-jointed emergency crank handle

** On request

BW Position of shaft support
LZ Clear frame dimension

Shaft operator WA 500 / 500 FU

with chain box

Shaft operator WA 500 / WA 500 FU for all track applications, except L, LD, HU, RD, RS, RK, VU and WS

As shown in the figure, the operator can be fitted either left or right, viewed from the inside. **In fitting example 5: on the side opposite the door lock.**

Fitting example ⑤ right

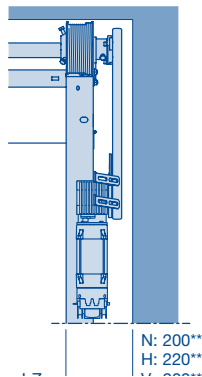
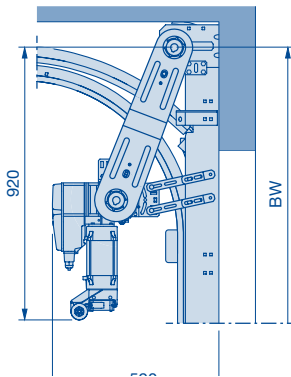

Fitting example ⑥ right

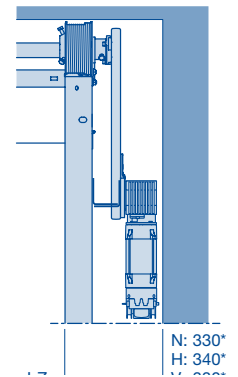
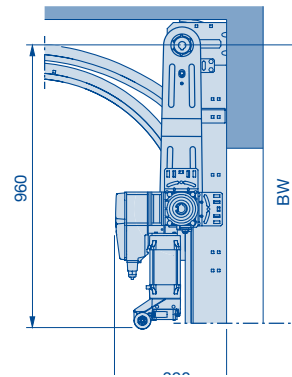

Shaft operator WA 500 / WA 500 FU for track applications L and LD

As shown in the figure, the operator can be fitted either left or right, viewed from the inside. **In fitting example 5: on the side opposite the door lock.**

Fitting example ⑤ right

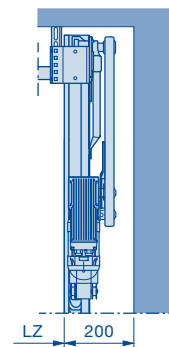
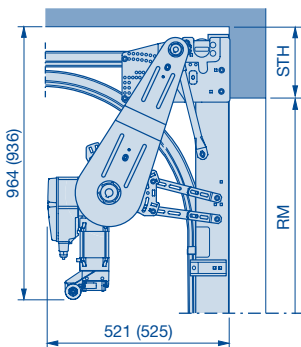

Fitting example ⑥ right

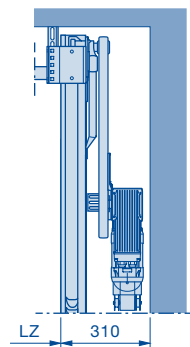
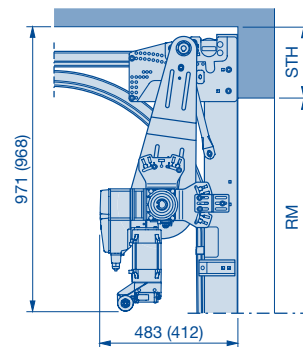

Dimensions in brackets () for low headroom track application with swivel mechanism.

Shaft operator WA 500 / WA 500 FU for track applications HU, RD, RS, RK, VU and WS

As shown in the figure, the operator can be fitted either left or right, viewed from the inside. **In fitting example 5: on the side opposite the door lock.**

Fitting example ⑤ right

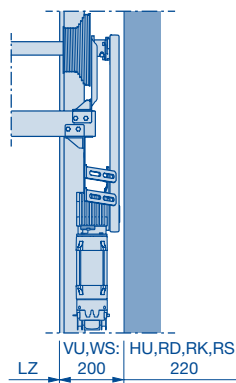
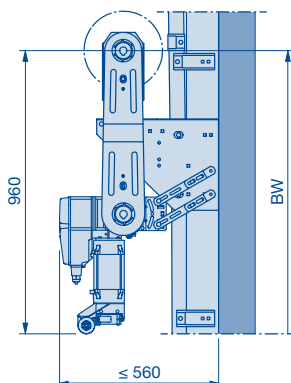

Fitting example ⑥ right

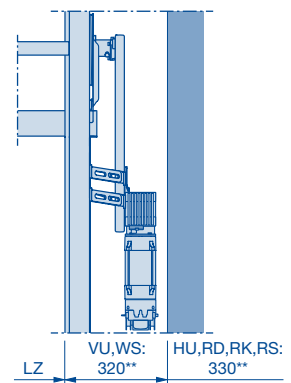
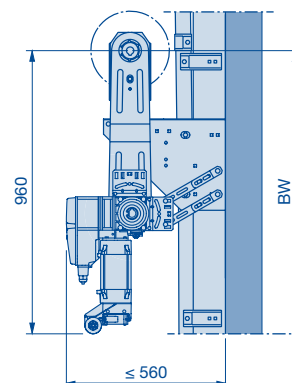

*** Note:**

Dimension + 75 mm if using a non-jointed emergency crank handle

**** Note:**

Dimension + 40 mm if using a non-jointed emergency crank handle

BW Position of shaft support
LZ Clear frame dimension

Shaft operator WA 500 / 500 FU

For central mounting

Shaft operator WA 500 / WA 500 FU for track applications: N and ND

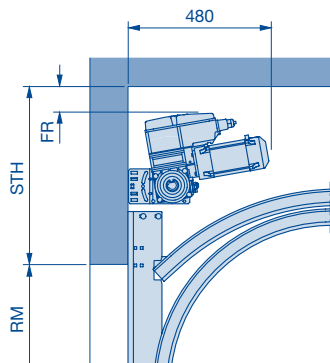

Track application	WA 500 / WA 500 FU	
	STH min.	FR min.
N 1	590	45
N 2	615	45
N 3	675	45
ND 1	550	48
ND 2	570	48
ND 3	675	48
ND 6	560	48
ND 7	640	48

Shaft operator WA 500 / WA 500 FU for track applications: NH and GD

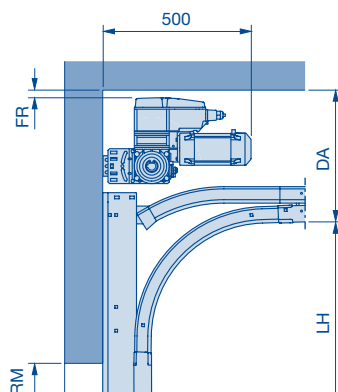

Track application	WA 500 / WA 500 FU	
	DA min.	FR min.
NH 1 / GD 1	480	45
NH 2 / GD 2	485	45
NH 3	565	45

Shaft operator WA 500 / WA 500 FU for track applications: NS, NK, GS and GK

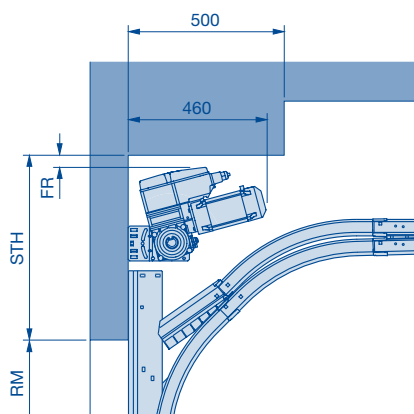

Track application	WA 500 / WA 500 FU	
	STH min.	FR min.
NS 1 / NK 1	615	45
NS 2 / NK 2	640	45
GS / GK	On request	

Note:

Centre motor in conjunction with double spring shaft on request!

DA Distance to ceiling
FR Clearance ceiling / shaft operator

LH Track height
RM Grid height

STH Headroom

Shaft operator WA 500 / 500 FU

For central mounting

Shaft operator WA 500 / WA 500 FU for track applications: H, HD, HS and HK

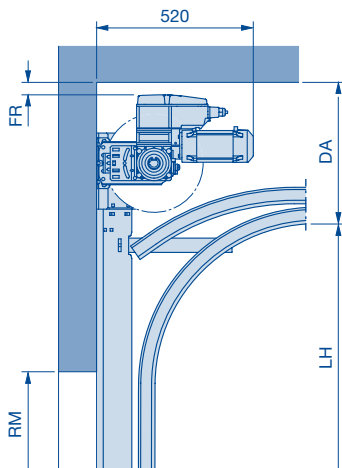

Track application	WA 500 / WA 500 FU	
	DA min.	FR min.
H 4	480	45
H 5	485	45
H 8	565	45
HD / HS / HK	On request	

Shaft operator WA 500 / WA 500 FU for track applications: HU, RD, RS and RK

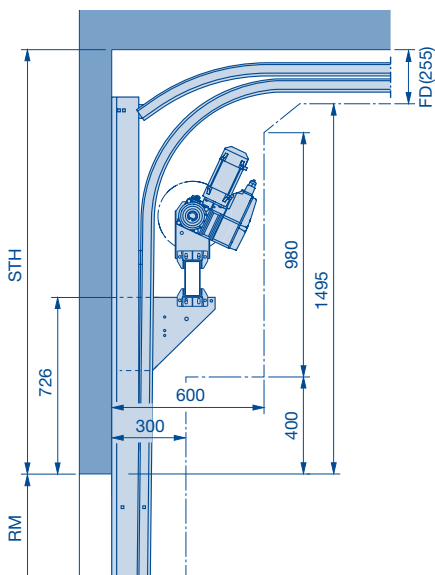

Track application	WA 500 / WA 500 FU
RS / RK	On request

Note:

Centre motor in conjunction with double spring shaft on request!

DA Distance to ceiling
FR Clearance ceiling / shaft operator

LH Track height
RM Grid height

STH Headroom

Shaft operator WA 500 / 500 FU

For central mounting

Shaft operator WA 500 / WA 500 FU for track applications: V and VS

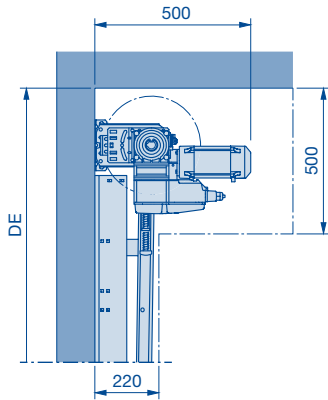

Track application	WA 500 / WA 500 FU
VS	On request

Shaft operator WA 500 / WA 500 FU for track applications: VU and WS

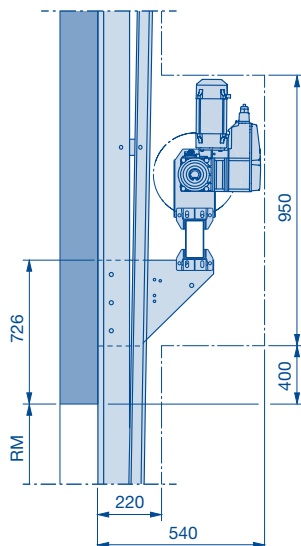

Note:

Centre motor in conjunction with double spring shaft on request!

DA Distance to ceiling
LH Track height

RM Grid height

Chain drive operator ITO 500 FU

ITO 500 FU track applications N and ND (doors with wicket doors on request)

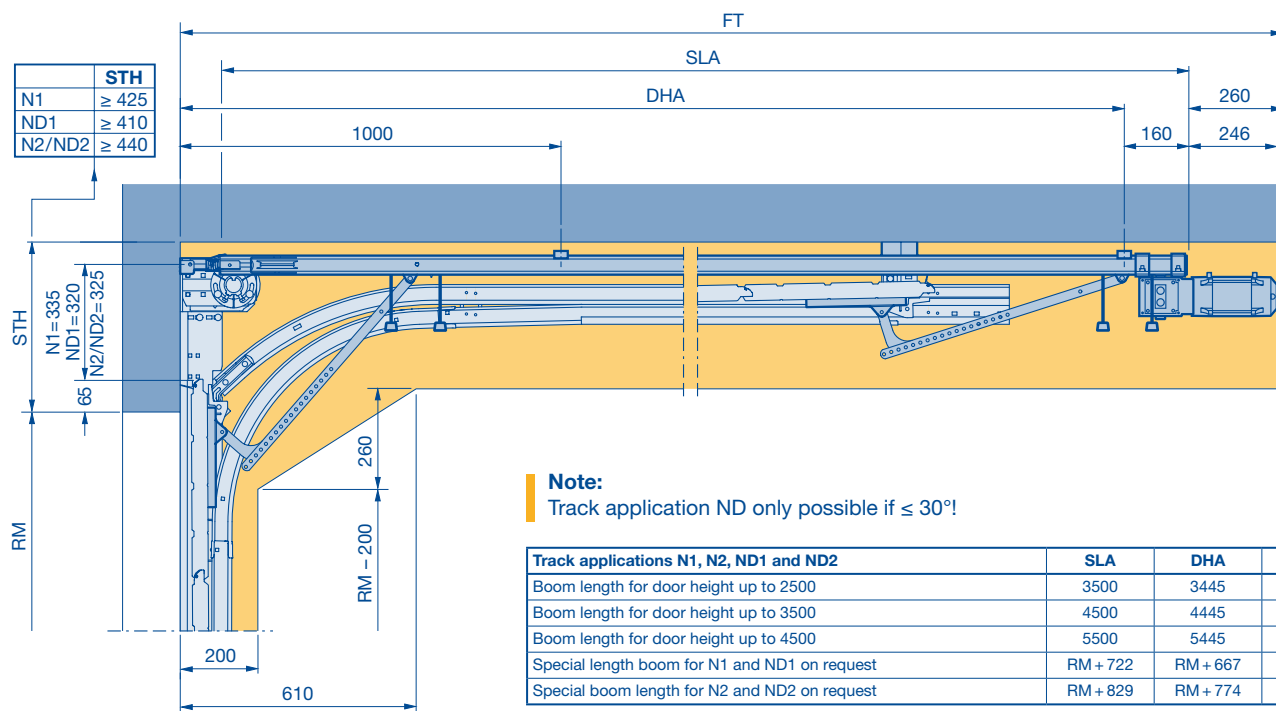

ITO 500 FU track applications L and LD (doors with wicket doors on request)

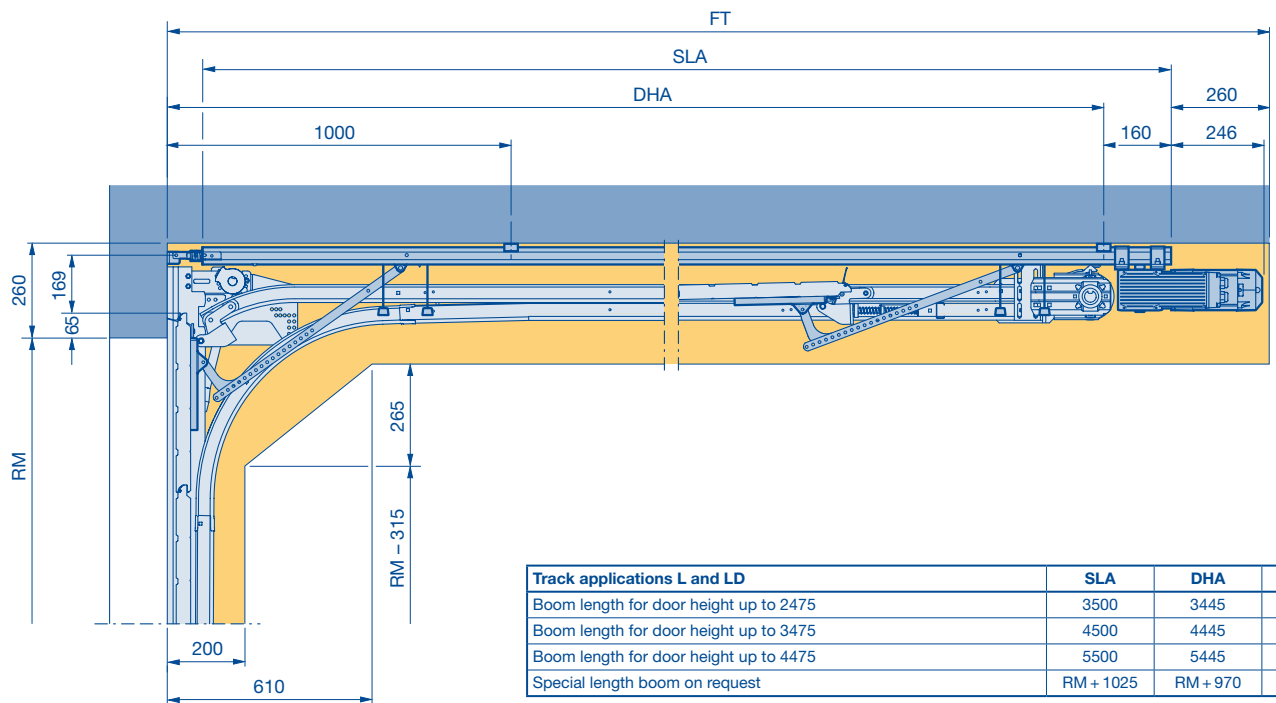

DHA Rear ceiling anchor operator
FT Clearance for door operator
RM Grid height
SLA Operator boom length

STH Headroom

Operator SupraMatic HT

SupraMatic HT track application N (doors with wicket door, ALR F42 Glazing, ALR F42 Vitraplan and doors with real glass infill on request)*

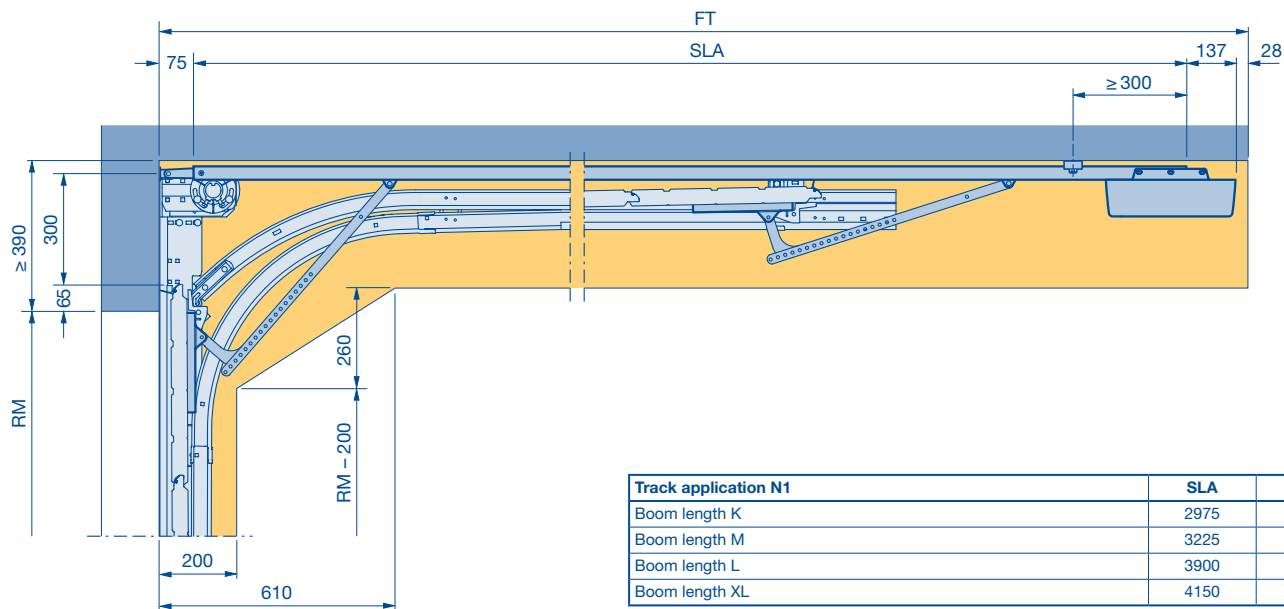

SupraMatic HT track application L (doors with wicket door, ALR F42 Glazing, ALR F42 Vitraplan and doors with real glass infill on request)*

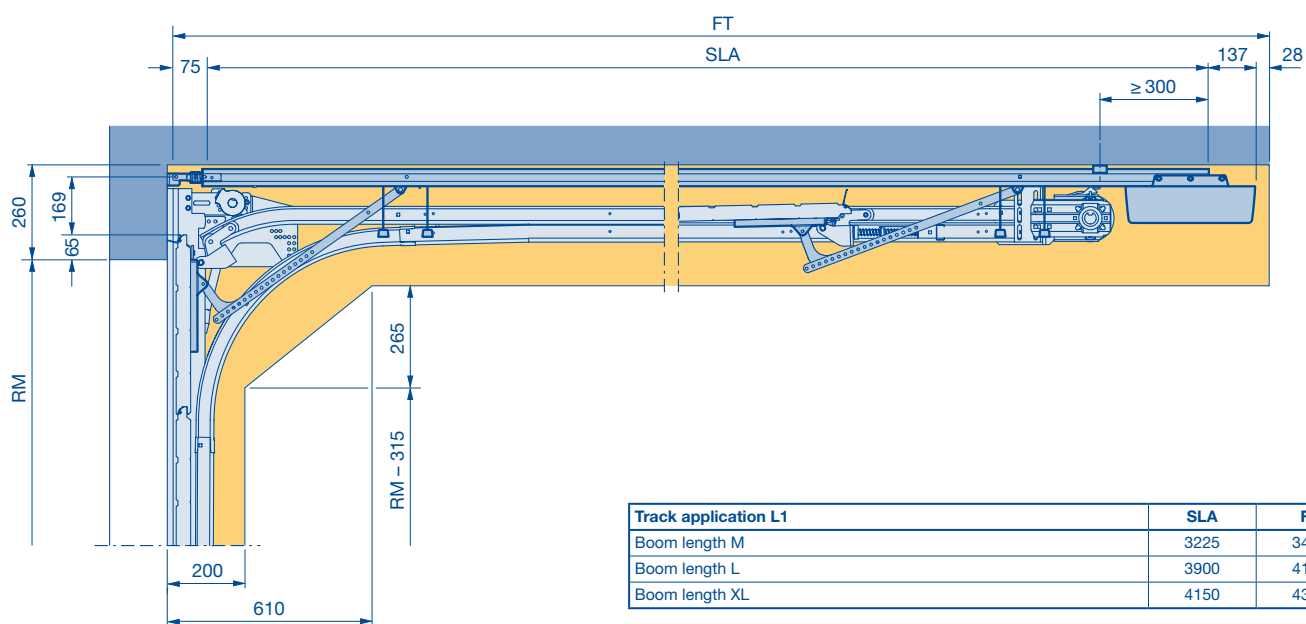

(See the next page for the size range for SupraMatic HT)

*** Note:**

Operator not possible for doors with a depth of 67 mm!

DHA Rear ceiling anchor operator
FT Clearance for door operator

RM Grid height
SLA Operator boom length

Operator SupraMatic HT

SupraMatic HT size range

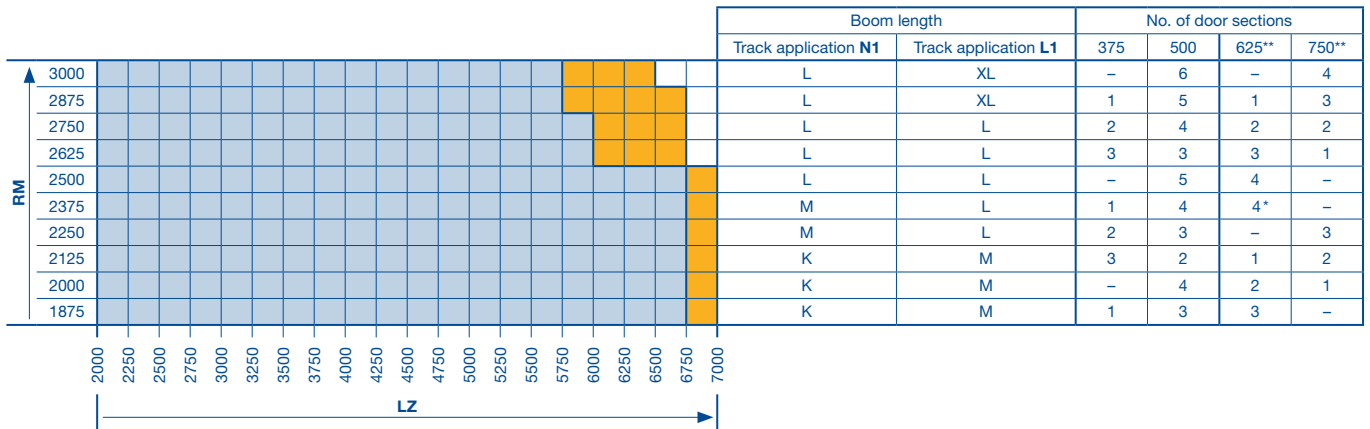

□ SupraMatic HT not possible.

■ SupraMatic HT possible.

■ SupraMatic HT on request.

LZ Clear frame dimension
RM Grid height
 * Top door section 500 mm
 ** Only without wicket door

Dimensions in mm

Door leaf speeds

WA 300 / WA 500

ATTENTION! The stated speeds can **only be achieved under optimum conditions** regarding door size and track size. More detailed information on request, as it is dependent on fitting, door and track heights.

Fitting area	WA 300 S4		WA 500							
	Integrated / external control 360		Control 545 and 560							
			Frame-mounted operator / centre motor				Chain box operator			
		[3]								
N1, NA1, NS1, ND1 ≤ 30°, NK1	190	95	30	190	30	190	30	190	30	190
GD1, GK1, GS1, NH1	190	95	16	100	16	100	16	100	16	100
ND6 > 30°	160 / 190 [1]	80 / 95 [1]	16	170 [1]	24	300 [1]	16	170 [1]	24	300 [1]
N2, NA2, NS2, ND2 ≤ 30°, NK2	210	105	24	210	30	265	24	210	30	265
GD2, GK2, GS2, NH2	210	105	16	142	16	142	16	142	16	142
ND7 > 30°	190 [1]	95 [1]	19 [2]	275 [1, 2]	19	275 [1]	13	180 [1]	19	275 [1]
N3, NH3, ND3 < 6°	-									
ND3 ≥ 6°							13	160	19	190
L1, LD1	210	105					24	150	24	150
L2, LD2										
H4, HA4, HK4, HS4, HU4, HD4, RD4, RK4, RS4	160 / 190 [1]	80 / 95 [1]	19 / 16	170 [1]	30 / 24	290 [1]	19 / 16	170 [1]	30 / 24	290 [1]
H5, HA5, HU5, HD5, RD5	210 [1]	105 [1]	24 / 19 [2]	290 [1, 2]	24 / 19		16 / 13		24 / 19	
H8, HD8, HK8, HS8, HU8	-						16 [2]	250 [2]	16	250
V6, VA6, VU6, VS6, WG6, WS6	160 / 190 [1]	80 / 95 [1]	16	170 [1]	24	300 [1]	16	170 [1]	24	300 [1]
V7, VU7, VS7, WG7, WS7	190 [1]	95 [1]	19 [2]	275 [1, 2]	19	275 [1]	13		19	275 [1]
V9, VU9, VS9, WS9	-						16 [2]	250 [2]	16	250

- [1] Max. door leaf speed depending on the high-lift / door height (RM) / door width (LZ)
 [2] Only possible with press-and-hold operation
 [3] Speed reduction in the range from 2500 mm above FFL to FFL to comply with EN 13241.







Note
 Double spring shaft only possible in conjunction with WA 500 FU!

	Speed in mm/s		Open / close direction of movement		Optosensors, 8k2 strip
	Speed in rotations per minute		Close direction of movement		Leading photocell VL1/VL2
	Power limit		Open direction of movement		Light grille HLG

Door leaf speeds

WA 500 FU









ATTENTION! The stated speeds can **only be achieved under optimum conditions** regarding door size and track size. More detailed information on request, as it is dependent on fitting, door and track heights.

Fitting area	WA 500 FU							
	Control 545							
	Frame-mounted operator / centre motor			Chain box operator				
								
N1, NA1, NS1, ND1 ≤ 30°, NK1	350	200			350	250		
GD1, GK1, GS1, NH1		250				250		
ND6 > 30°		250				250		
N2, NA2, NS2, ND2 ≤ 30°, NK2	500	500			500	500		
GD2, GK2, GS2, NH2		200	300	500		200	300	500
ND7 > 30°		500				500		
N3, ND3		500				500		
NH3		200	300	500		200	300	500
L1, LD1	-			375	200	300	375	
L2, LD2	-				375			
H4, HA4, HK4, HS4, HU4, HD4, RD4, RK4, RS4	350	200	250		350	200	250	
H5, HA5, HU5, HD5, RD5	500	500			500	500		
H8, HD8, HK8, HS8, HU8		500				500		
V6, VA6, VU6, VS6, WS6	350	200	250		350	200	250	
V7, VU7, VS7, WS7	500	500			500	500		
V9, VU9, VS9, WS9		500				500		

Max. door leaf speed from the open end-of-travel position in the close direction up to approx. 3200 mm above FFL

Max. door leaf speed from the open end-of-travel position in the close direction up to approx. 500 mm above FFL

Note
Double spring shaft only possible in conjunction with control WA 500 FU!

	Speed in mm/s		Open / close direction of movement		Optosensors, 8k2 strip
	Speed in rotations per minute		Close direction of movement		Leading photocell VL1/VL2
	Power limit		Open direction of movement		Light grille HLG

Door leaf speeds

WA 500 FU

ATTENTION! The stated speeds can **only be achieved under optimum conditions** regarding door size and track size. More detailed information on request, as it is dependent on fitting, door and track heights.

Fitting area	WA 500 FU											
	Control 560											
	Frame-mounted operator / centre motor				Chain box operator				Top speed (mm/s) [4]			
	↑		↓		↑		↓		↑		↓	
N1, NA1, NS1, ND1 ≤ 30°, NK1	500 575 [4]				500 575 [4]				700 [4]	200	300	500
GD1, GK1, GS1, NH1	500	200	300	500	500	200	300	500	-			
ND6 > 30°	500				500				700 [4]	200	300	500
N2, NA2, NS2, ND2 ≤ 30°, NK2	500 825 [4]	500	500	500 825	500 825 [4]	500	500	500 825	1000 [4]	500	500	1000
GD2, GK2, GS2, NH2	500	200	300	500	500	200	300	500	-			
ND7 > 30°	500 825 [4]	500	500	500 825	500 825 [4]	500	500	500 825	1000 [4]	500	500	1000
N3, ND3	1000 [4]	500	500	500	1000 [4]	500	500	500	1000 [4]	500	500	1000
NH3	500	200	300	500	500	200	300	500	-			
L1, LD1	-				375	200	300	375	1000 [4]	200	300	500
L2, LD2	-				575 [4]			500		500	500	1000
H4, HA4, HK4, HS4, HU4, HD4, RD4, RK4, RS4	500 700 [4]	200	300	500	500 700 [4]	200	300	500	700 [4]	200	300	500
H5, HA5, HU5, HD5, RD5	500 825 [4]	500	500	500 825	500 825 [4]	500	500	500 825	1000 [4]	500	500	1000
H8, HD8, HK8, HS8, HU8	500	500	500	500	500	500	500	500	1000 [4]	500	500	1000
V6, VA6, VU6, VS6, WS6	500 700 [4]	200	300	500	500 700 [4]	200	300	500	700 [4]	200	300	500
V7, VU7, VS7, WS7	500 825 [4]	500	500	500 825	500 825 [4]	500	500	500 825	1000 [4]	500	500	1000
V9, VU9, VS9, WS9	500	500	500	500	500	500	500	500	1000 [4]	500	500	1000

[4] Max. door leaf speed with door width (LZ) ≤ 6000 mm; For door width (LZ) > 6000 mm only after technical inspection; not possible with roller holder type S
Max. door leaf speed from the open end-of-travel position in the close direction up to approx. 3200 mm above FFL
Max. door leaf speed from the open end-of-travel position in the close direction up to approx. 500 mm above FFL

Note
Double spring shaft only possible in conjunction with control WA 500 FU!

Sectional door

Parcel

SPU F42

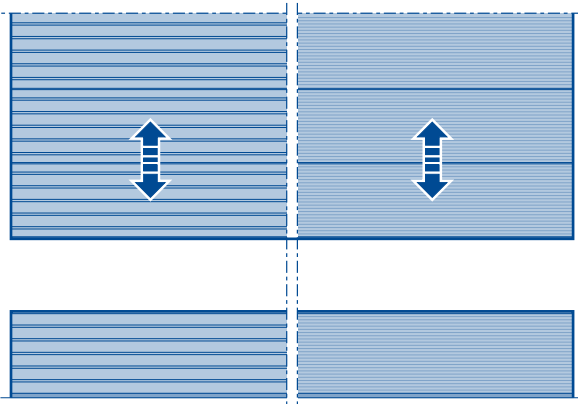

APU F42

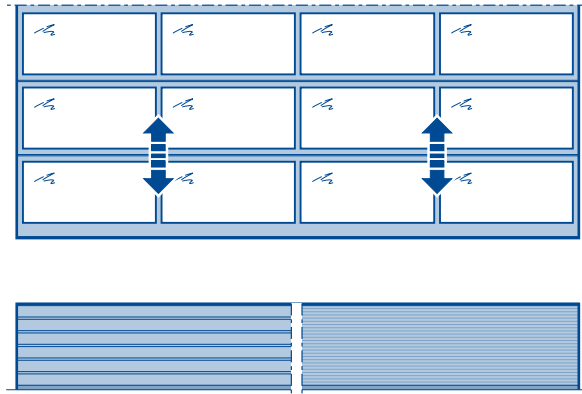

Functional principle

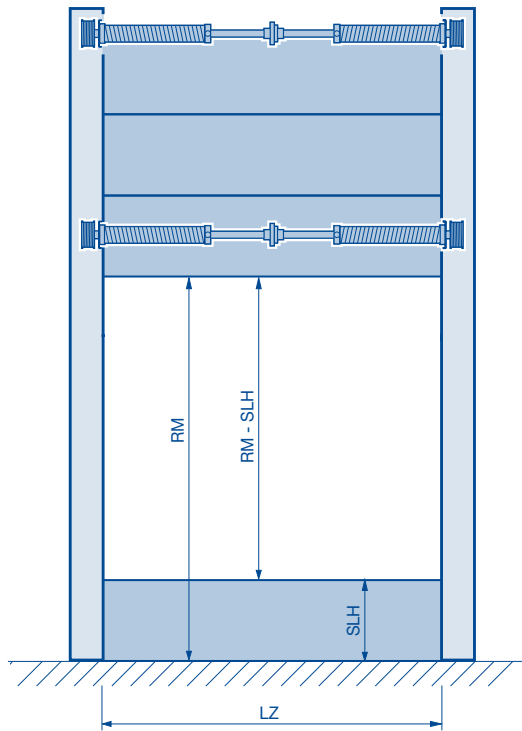

For loading lorries and swap trailers, the bottom section with the catwalk remains on the ground when the door is open.

*For Parcel, LDH = RM possible on request

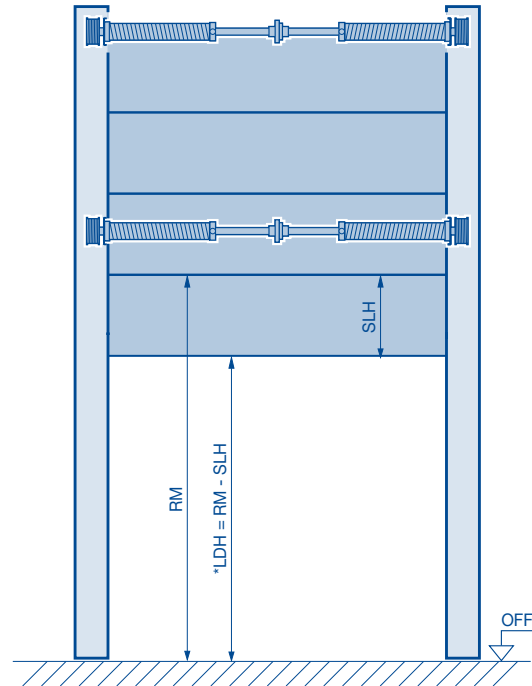

Vans are loaded at floor level. For this purpose, the door is opened completely including the bottom section. When the coupled door is open, the bottom section with the catwalk remains in the top part of the door opening.

- LDH Clear passage height
- LZ Clear frame dimension
- RM Grid height
- SLH Bottom section height

Dimensions in mm

Sectional door

Parcel

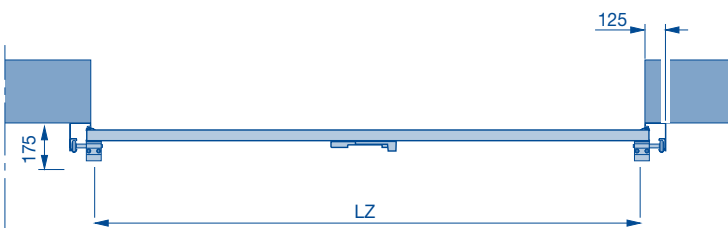
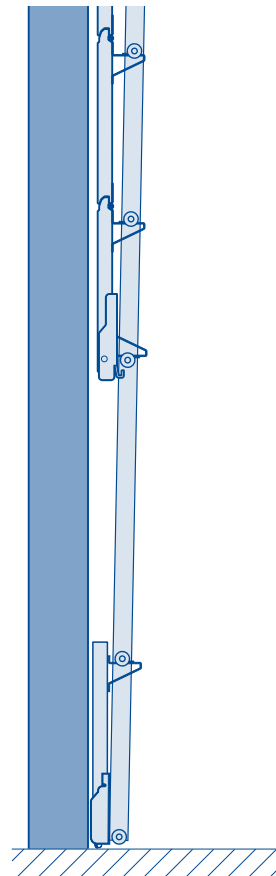
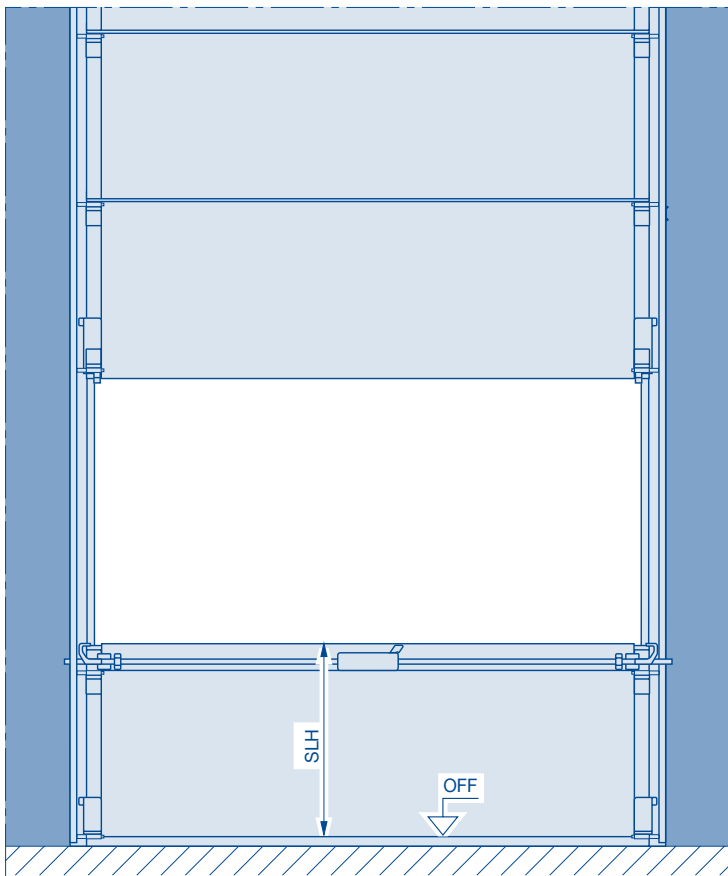

LZ Clear frame dimension
SLH Bottom section height
Dimensions in mm

Track application: HP

High-lift track application

for sectional door Parcel with high- and low-mounted torsion spring shaft

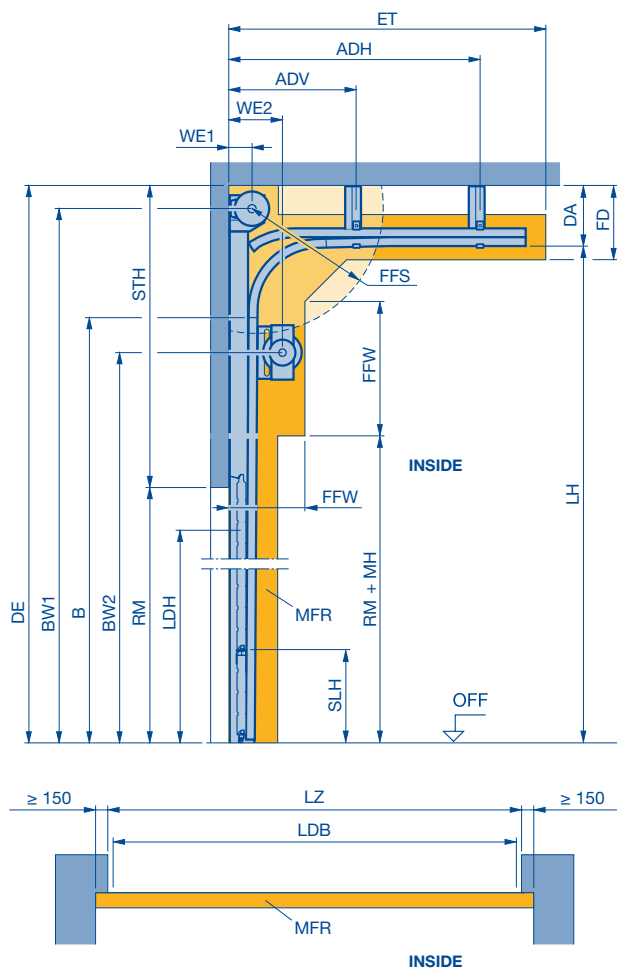

ADH Distance to rear ceiling anchor on request
ADV Distance to ceiling anchor, front
B Start of double radius
BW Position of shaft support
DA Distance to ceiling
DE Ceiling height
ET Distance back on request
FD Min. ceiling clearance
FFS Spring tensioning clearance
FFW Spring shaft clearance
LDB Clear passage width with ThermoFrame (see page 82)

LDH Clear passage height
 For Parcel, LDH = RM is available on request
LH Track height (see table)
LZ Clear frame dimensions (from 1500)
MFR Space for fitting the door on request
MH Fitting height
OFF Finished floor level (FFL)
RM Grid height
SLH Bottom section height
STH Min. headroom (see page 56)
WE Shaft centre from lintel (see table)

Please note:

1. Select required track height according to the door height in table.
2. A technical inspection is required!

Notes:

- Only for door types SPU F42 and APU F42
- Operators WA 300 and WA 500 are only possible in press-and-hold operation.
- A frame below the door division is not possible
- Application range from LZ 1500 – 3000 mm and RM from 3125 – 4250 mm.
- Doors with wicket door are not possible.
- The clearance required for fitting the door must be free of supply lines, heater fans, etc.

Notes:

- Follow the instructions for the approved size ranges for door types SPU F42 and APU F42 from the table!

Table: Track heights (LH)

Door height	RM	Min. LH	Max. LH
4250		5810	On request
4125		5685	
4000		5560	
3875		5435	
3750		5310	
3625		5185	On request
3500		5060	
3375		4935	
3250		4810	
3125		4685	

	B	BW1	BW2	DA	WE1	WE2
HP 4	LH - 366	LH + 231	RM + 940	Min. 370	160	315
HP 5				Min. 400	180	

DAL	FD	FFS	FFW	LDH	MH	SLH
DE - LH - 15	DA + 65	min. 90° (745)	460 × 850	RM - SLH	400	500 – 1450

Track application: VP

Vertical track application

for sectional door Parcel with high- and low-mounted torsion spring shaft

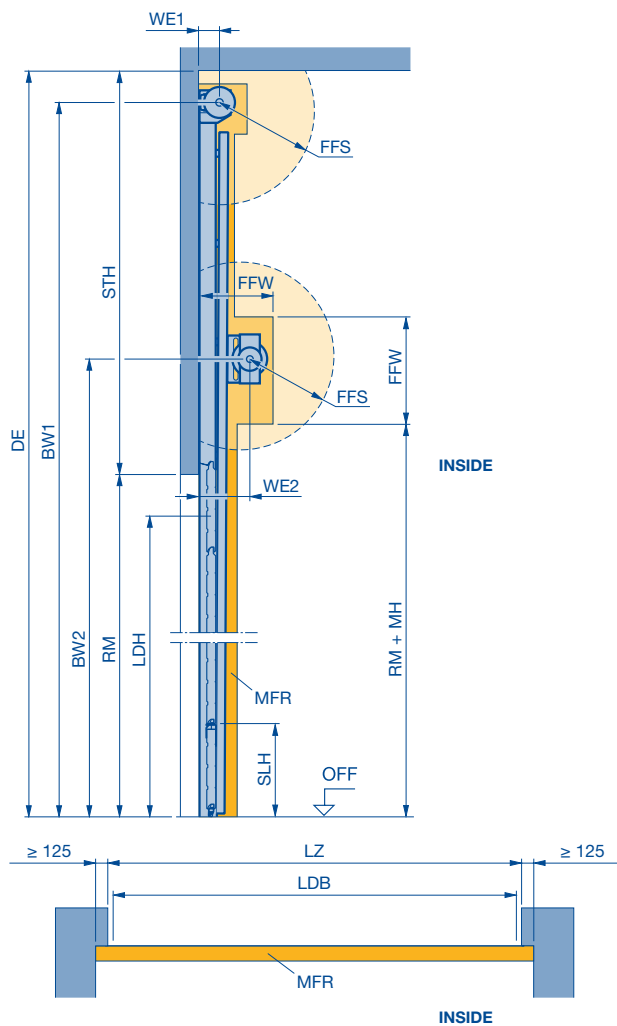

BW	Position of shaft support, BW1 on request	LZ	Clear frame dimensions (from 1500)
DE	Ceiling height, on request	MFR	Space for fitting the door, on request
FFS	Spring tensioning clearance	MH	Fitting height
FFW	Spring shaft clearance	OFF	Finished floor level (FFL)
LDB	Clear passage width with ThermoFrame (see page 82)	RM	Grid height
LDH	Clear passage height	SLH	Bottom section height
	For Parcel, LDH = RM is possible	STH	Headroom, on request
		WE	Shaft centre from lintel

Please note:
A technical inspection is required!

- Notes:**
- Only for door types SPU F42 and APU F42
 - Operators WA 300 and WA 500 are only possible in press-and-hold operation.
 - A frame below the door division is not possible
 - Application range from LZ 1500 – 3000 mm and RM from 3125 – 4250 mm.
 - Doors with wicket door are not possible.
 - The clearance required for fitting the door must be free of supply lines, heater fans, etc.

Observe min. sideroom, see page 82.

	BW2	FFS	FFW	LDH	MH	SLH	WE1	WE2
VP 6							160	
VP 7	RM + 940	min. 90° (745)	460 x 850	RM - SLH	400	500 – 1450	180	315

Movable centre support

For industrial sectional doors with an opening width of up to 24 m

- This door combination allows for particularly large openings to be closed conveniently and economically by coupling two or three industrial sectional doors.
- This door combination is particularly economical to transport, fit and service.
- For complete opening, the doors are opened and the centre support is then unlocked and pushed to the side.
- The individual doors can also be opened independently of each other so that the opening can also be done in segments.

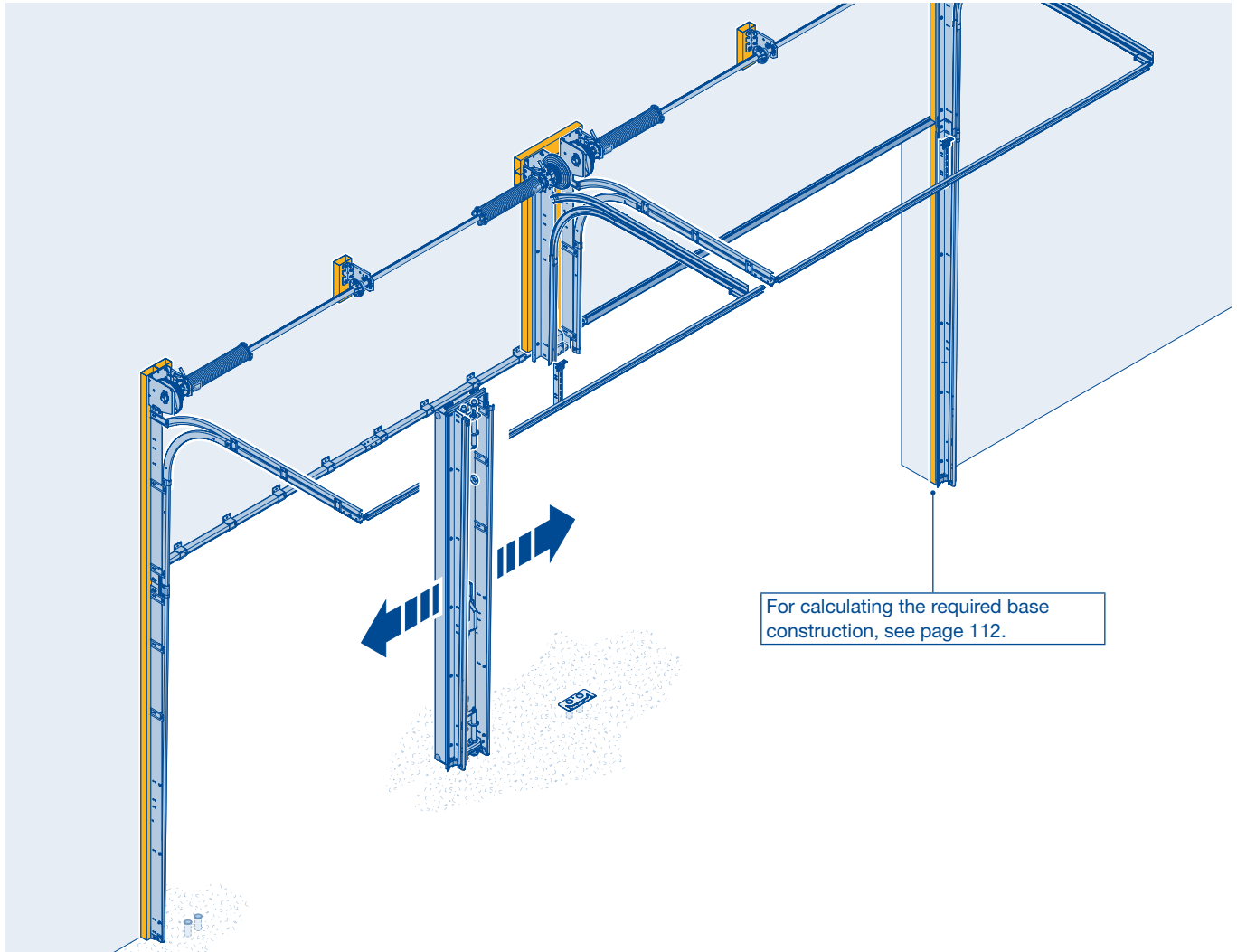

Notes:

- Only with track application H.
- All door types possible.
- Depth 42 mm, application range from LZ ≤ 8000 mm and RM ≤ 7500 mm.
- Please refer to the technical manual for the depths!
- Version with plastic frame shoe.
- Wicket door version only possible with high threshold rail.
- Panel as lintel fitting not possible.
- No special versions (e.g. chamfered bottom section, lowered section, Parcel) possible.

Notes:

- The clearance required for fitting the door must be free of supply lines, heater fans, etc.
- Factory drawing required. Approval only with drawing! Information about the structural conditions is relevant.
- Door fitting recommended for unheated buildings. Air permeability, acoustic value and thermal resistance – npd (not specified)
- Wind class 2–4 according to the technical manual.
- Available in standard programme!

LZ Clear frame dimension
RM Grid height

Movable centre support

For industrial sectional doors with an opening width of up to 24 m

Centre support

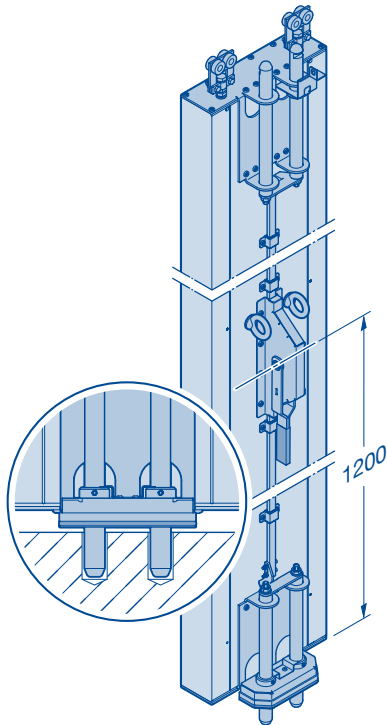

Notes:

- Aluminium material version based on RAL 9002, exterior with line design.
- Surface with wet coating on exterior and interior.
- Width: 375 mm
- Height: RM – 60 mm
- Shifting direction for one centre support, outer left or outer right.
- Shifting direction for two centre supports, outer left or outer right.
- The shifting direction depends on which door system the centre support is ordered for.
- Cladding of the centre support is not possible.

Door operation:

- Only power-driven with WA 500 FU.
- Flange, chain box and emergency operation are only possible with the exterior door systems.
- A centre door system can only be used as a chain box with fitting example 5.

Safety equipment:

- Safety edge is only possible with optosensors or 8K2 strip.

Operator accessories:

- A radio activating kit must be used for the centre door system!
- Further accessories on request.

Fitting:

- The door system with centre support may only be assembled when the floor is finished.
- A base construction of 60 mm is required in the area of the door frame and the spring shaft.

Recommendation: Industrial additional post 120 / 60 / 2.

Maximum load

- on the head plate

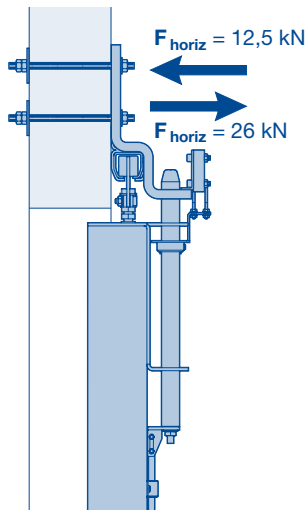

- on the track

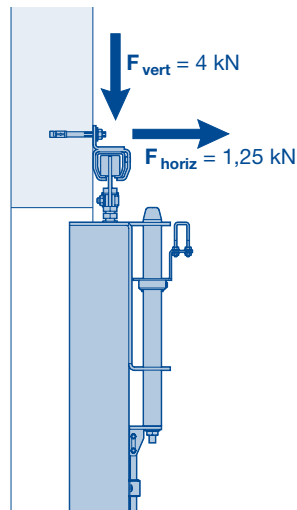

- per floor sleeve

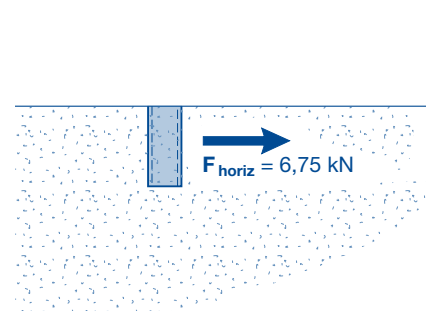

F_{horiz}	Horizontal force at the fixing point
F_{vert}	Vertical force at the fixing point
LZ	Clear frame dimension
RM	Grid height

Movable centre support

Possible variants of the base construction

Segmented base construction

Combination with **two** industrial sectional doors

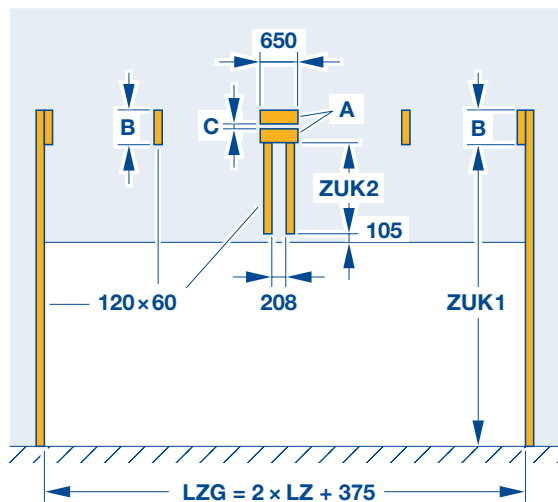

Combination with **three** industrial sectional doors

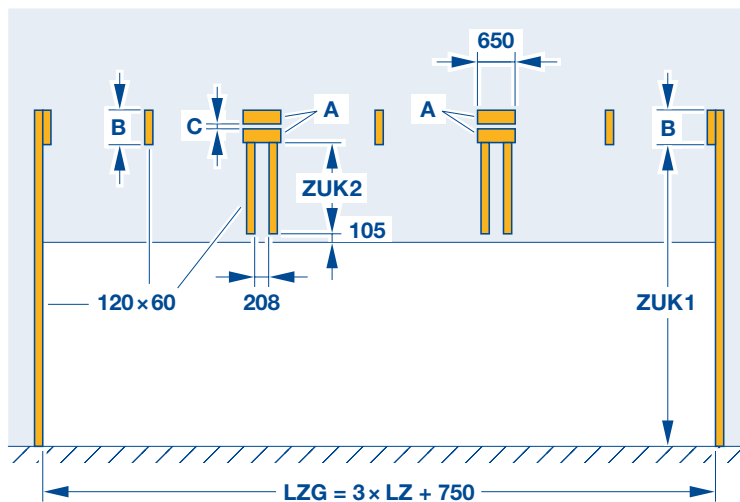

Solid base construction

Combination with **two** industrial sectional doors

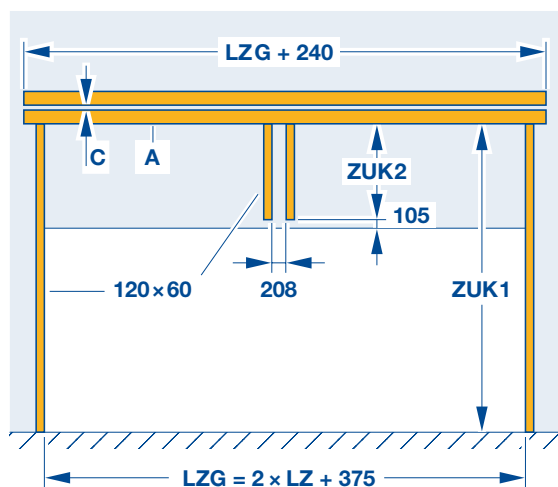

Combination with **three** industrial sectional doors

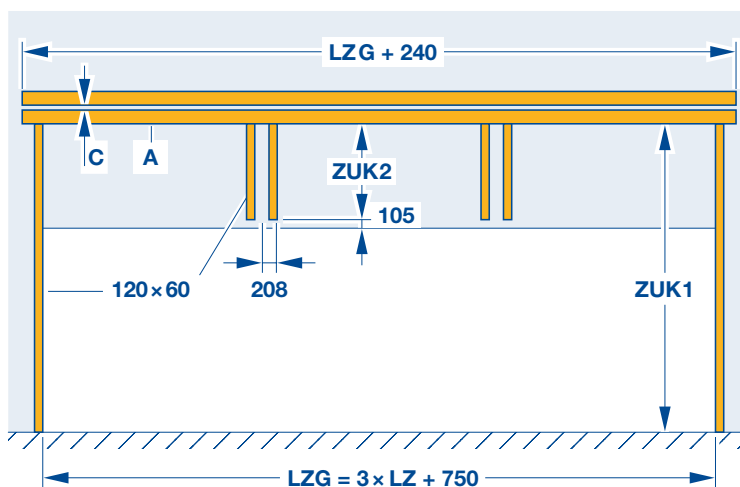

Note:
Position of shaft support **BW**, see page 113.

	A	B	C	ZUK 1	ZUK 2
Simple spring shaft	120 x 60	300	0	BW - 145	BW - RM - 250
Double spring shaft	200 x 60	500	45	BW - 115	BW - RM - 220

BW Position of shaft support
LZ Clear frame dimension
LZG Clear frame dimension, total
RM Grid height

ZUK Door frame, base construction

Infill overview

Determination of the roof slope

Infill overview	SPU F42	APU F42	APU F42 Thermo	ALR F42	ALR F42 Thermo	ALR F42 Glazing	ALR F42 Vitraplan	ALR F42 Vitraplan AT
Infill type	Abbreviation							
Clear synthetic pane, 3 mm [1] [3]	FK	FK	-	FK	-	-	-	-
Crystal structure synthetic pane, 3 mm [1] [3]	KR	KR	-	KR	-	-	-	-
Clear polycarbonate pane, 6 mm [3]	P	P	-	P	-	-	-	-
Multiple moulded pane, 16 mm, $U_g = 1.9 \text{ W/m}^2\cdot\text{K}$ [3]	S	S	S	S	S	-	-	-
PU infill, 26 mm with aluminium sheet cover Stucco-textured on both sides, $U_g = 1.0 \text{ W/m}^2\cdot\text{K}$	-	FU	FU	FU	FU	-	-	FU
PU infill, 26 mm with smooth, anodised aluminium sheet cover on both sides, $U_g = 1.0 \text{ W/m}^2\cdot\text{K}$	-	XU	XU	XU	XU	-	-	XU
PU infill, 26 mm with smooth, anodised aluminium sheet cover on both sides, $U_g = 1.2 \text{ W/m}^2\cdot\text{K}$ [6]	TU	TU	TU	TU	TU	-	-	-
Clear synthetic double pane, 26 mm, $U_g = 2.6 \text{ W/m}^2\cdot\text{K}$	S2	S2	S2	S2	S2	-	S2	-
Synthetic double pane, crystal structure, 26 mm, $U_g = 2.6 \text{ W/m}^2\cdot\text{K}$	U2	U2	U2	U2	U2	-	U2	-
Synthetic double pane, grey tinted, 26 mm, $U_g = 2.6 \text{ W/m}^2\cdot\text{K}$	A2	A2	A2	A2	A2	-	A2	-
Synthetic double pane, white tinted (opal), 26 mm, $U_g = 2.6 \text{ W/m}^2\cdot\text{K}$	M2	M2	M2	M2	M2	-	-	-
Clear synthetic triple pane, 26 mm, $U_g = 1.9 \text{ W/m}^2\cdot\text{K}$	S3	S3	S3	S3	S3	-	S3	-
Synthetic triple pane, crystal structure, 26 mm, $U_g = 1.9 \text{ W/m}^2\cdot\text{K}$	U3	U3	U3	U3	U3	-	U3	-
Synthetic triple pane, grey tinted, 26 mm, $U_g = 1.9 \text{ W/m}^2\cdot\text{K}$	A3	A3	A3	A3	A3	-	A3	-
Synthetic triple pane, white tinted (opal), 26 mm, $U_g = 1.9 \text{ W/m}^2\cdot\text{K}$	M3	M3	M3	M3	M3	-	-	-
Clear polycarbonate double pane, 26 mm, $U_g = 2.7 \text{ W/m}^2\cdot\text{K}$	C2	C2	C2	C2	C2	-	C2	-
Single pane of laminated safety glass, 6 mm [2] [3]	VG	VG	-	VG	-	VG	-	-
Double pane made of single-pane safety glass, 26 mm, $U_g = 2.6 \text{ W/m}^2\cdot\text{K}$ [2]	E2	E2	E2	E2	E2	E2	-	-
Double pane made of laminated safety glass P4A, 26 mm, $U_g = 1.3 \text{ W/m}^2\cdot\text{K}$ [6]	W2	W2	W2	W2	W2	-	-	-
Climatic double pane made of single-pane safety glass, 26 mm, $U_g = 1.1 \text{ W/m}^2\cdot\text{K}$ [2]	G2	G2	G2	G2	G2	G2	-	-
Stainless steel expanded mesh, 5 mm [1] [3] [4]	SE	SE	-	SE	-	-	-	-
Perforated stainless steel sheet, 1.5 mm, perforation 8 mm [1] [3] [4]	LB	LB	-	LB	-	-	-	-
Prepared for on-site infill [5]	BS	BS	BS	BS	BS	-	-	-

- [1] **Note:** max. field width 1230 mm, if required add an additional field
- [2] Only for door width up to 6000 mm; on request
- [3] Not possible for aluminium frames in Thermo version
- [4] No colour coating possible

- [5] On request; infill weight and thickness must be specified (anodised glazing beads required)
- [6] Only for NT60 and NT80 Thermo with RC2 version and door version with glazing type A

Determination of the roof slope in steps of two degrees (a°)

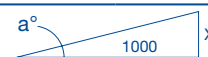

a°	%	X (mm)	a°	%	X (mm)	a°	%	X (mm)
2	3,49	34,9	16	28,67	286,7	30	57,74	577,4
4	6,99	69,9	18	32,49	324,9	32	62,49	624,9
6	10,51	105,1	20	36,40	364,0	34	67,46	674,6
8	14,05	140,5	22	40,40	404,0	36	72,66	726,6
10	17,63	176,3	24	44,52	445,2	38	78,13	781,3
12	21,26	212,6	26	48,77	487,7	40	83,91	839,1
14	24,93	249,3	28	53,17	531,7	42	90,05	900,5
						44	96,57	965,7
						46	103,55	1035,5

Overview

Profile cylinders

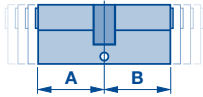
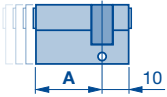
Product type	 Double cylinder	 Half cylinder	Glazing frame	Door lock		Wicket door	Optional extras	Operator accessories
	PC length (L): Interior (A) + exterior (B)	PC length (L): Closing side (A) + blind side		Infill	Standard			
SPU F42 APU F42 APU F42 Thermo	L = 35 + 30	–	–	–	–	●	●	–
	–	L = 30 + 10	–	–	●	●	–	●
	–	L = 35 + 10	–	–	–	–	●	–
	–	L = 70 + 10	–	●	–	–	–	–
ALR F42 ALR F42 Thermo	L = 35 + 30	–	–	–	–	●	●	–
	–	L = 30 + 10	–	–	–	●	–	●
	–	L = 35 + 10	–	–	–	–	●	–
	–	L = 55 + 10	FU and XU	●	–	–	–	–
NT 60	L = 40 + 40	L = 40 + 10	–	–	–	–	–	–
NT 80	L = 35 + 70	L = 35 + 10	–	–	–	–	–	–
NT 60 RC2	L = 35 + 40*	–	–	–	–	–	–	–
NT 80 RC2	L = 35 + 60*	–	–	–	–	–	–	–

* Profile cylinder in acc. with DIN 1303
(point 7 = class 5, point 8 = class 1)

Brand quality for residential and commercial construction

The family-owned company Hörmann offers all important construction components for building and renovating projects from a single source. We manufacture in highly-specialised factories using the latest production technologies. Furthermore, our employees work intensively on new products, continual further developments and improvements to details. The results are patents and one-of-a-kind products you can depend on.

