



Technical product description

High-speed spiral door

High-speed turbo door

High turbo-speed roll-up door



For internal use only

This technical product description
applies to the following door system types:

EFA-SST® -L Premium

EFA-SST® -L Eco

EFA-SST® -L Basic

EFA-STT® -L Premium

EFA-STT® -L Eco

EFA-STT® -L Basic

EFA-STR® -L Premium

EFA-STR® -L Eco

EFA-STR® -L Basic

EFA-SST® -L Classic Premium

EFA-SST® -L Classic Eco

EFA-SST® -L Classic Basic

EFAFLEX Tor- und Sicherheitssysteme GmbH & Co. KG

Fliederstraße 14

84079 Bruckberg

GERMANY

Telephone: +49 8765 82-0

Fax: +49 8765 82-200

Email: info@efaflex.com

Internet: www.efaflex.com

Translation of the original

Version 01-EN

04.06.2024

© EFAFLEX Tor- und Sicherheitssysteme GmbH & Co. KG

Door system designations

Designation	Official product name of door system	Spiral type	Designation of version / design	Installation drawing (EZ) number
290 R	EFA-SST® -L Premium	Round spiral	EFA-THERM®	003-xx
291 R	EFA-SST® -L Eco	Round spiral		
292 R	EFA-SST® -L Basic	Round spiral		
320 R	EFA-STT® -L Premium	Round spiral	EFA-CLEAR®	
321 R	EFA-STT® -L Eco	Round spiral		
322 R	EFA-STT® -L Basic	Round spiral		
330 R	EFA-STR® -L Premium	Round spiral	Door leaf with cover	
331 R	EFA-STR® -L Eco	Round spiral		
332 R	EFA-STR® -L Basic	Round spiral		
340 R	EFA-SST® -L Classic Premium	Round spiral	EFA-ALUX®	
341 R	EFA-SST® -L Classic Eco	Round spiral		
342 R	EFA-SST® -L Classic Basic	Round spiral		

Table of contents

1	Short description	6
2	Technical properties	8
	2.1 Use.....	8
	2.2 Dimensions.....	8
	2.3 Speeds.....	9
	2.4 Performance properties.....	10
	2.5 Fire performance.....	11
	2.6 Safety standards.....	12
	2.7 Performance.....	12
3	Construction of the high-speed spiral door	13
	3.1 Spiral case.....	15
	3.1.1 Transmission of force.....	18
	3.2 Side frames.....	18
	3.2.1 Counterbalance.....	19
	3.2.2 Manual release lever.....	20
	3.2.3 Door locking mechanism.....	21
	3.2.4 Door leaf guide.....	26
	3.2.5 Side frame extension.....	27
	3.2.6 Flexible closing strip extension.....	28
	3.2.7 Rigid closing strip extension.....	30
	3.2.8 End positions.....	31
	3.2.9 Spring or belt break detector.....	35
	3.3 Resistance class.....	35
	3.4 Door leaf, laths and door leaf design.....	38
	3.4.1 Door systems 290 R; 291 R; 292 R.....	38
	3.4.2 Door systems 320 R; 321 R; 322 R.....	47
	3.4.3 Door systems 330 R; 331 R; 332 R.....	50
	3.4.4 Door systems 340 R; 341 R; 342 R.....	53
	3.4.5 Corrosion protection.....	57
	3.5 Seal.....	61
	3.5.1 Seal for 290 R; 291 R; 292 R; 320 R; 321 R; 322 R; 340 R; 341 R; 342.....	61
	3.5.2 Seal on 330 R; 331 R; 332 R.....	63
	3.6 Drives.....	64
	3.7 Control units.....	64
	3.8 Integrated control unit.....	68
4	Door safety	70
	4.1 Safety edge and light barrier.....	71
	4.2 Door light grid.....	71
	4.3 EFA-SCAN®.....	72
5	Equipment packages	73
6	Surface design drawings	76
	6.1 Component coating type.....	77

6.2 Stainless steel design components (V2A)..... 82

7 Packaging units..... 87

1 Short description

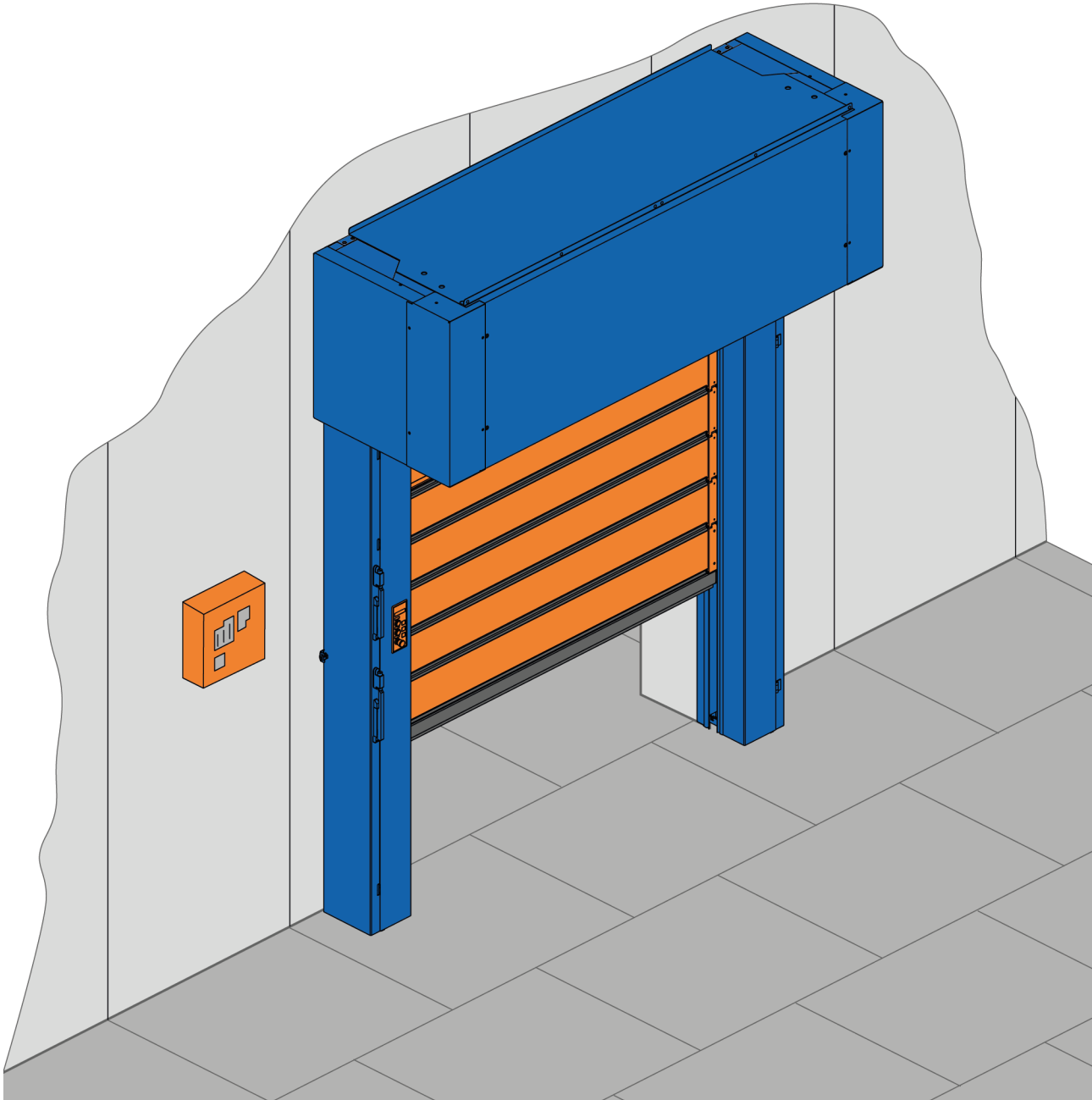

Fig. 1: High-speed spiral door

High-speed spiral doors, high-speed turbo doors and high-speed turbo roll-up doors of the S series are door systems designed for industrial and commercial purposes. The basic construction is based on tried and tested spiral door technology.

The designs are based on a platform model, enabling the following door leaf versions can be used in the same basic construction. This means that the side frames and the spiral cases are identical. As a result all options, such as EFA-SCAN® or limit switches, are available for all door leaf versions.

The high-insulation door leaf for the EFA-SST® is equipped with 40 mm thick EFA-THERM® and optionally with EFA-CLEAR® transparent laths or EFA-VENT® ventilation laths.

The door leaf for the EFA-SST® Classic is equipped with 30 mm thick, double-walled extruded aluminium laths (EFA-ALUX®) with a spacing of 151 mm, or optionally with a spacing of 225 mm.

The door leaf for the EFA-STT® is equipped with 30 mm thick extruded aluminium profiles and a pressure-grouted, single-wall filling (EFA-CLEAR®) with a spacing of 225 mm.

The door leaf for the EFA-STR® is equipped with 40 mm thick extruded aluminium profiles and a polyester fabric filling, which is secured tightly with keder profiles. The extruded profiles have a spacing of 225 mm.

Technical properties

Dimensions

2 Technical properties

2.1 Use

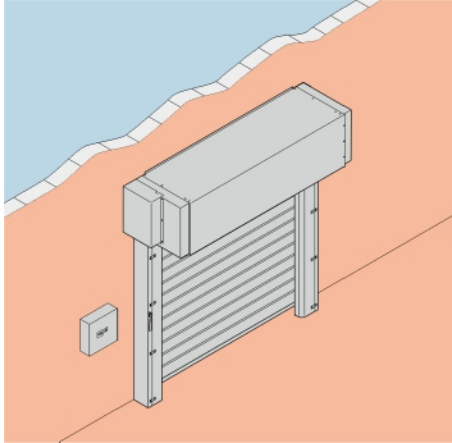

Fig. 2: Use

Use

- Industrial door
- Hall door
- Outdoor installation under a canopy provided by the owner possible
- Interior door

	Outdoors (-15 °C to +50 °C)
	Indoors (+5 °C to +50 °C)



The control cabinet must be installed in an ambient temperature of > +5 °C.

** Excluding packages, see chapter 5 Equipment packages.*

2.2 Dimensions

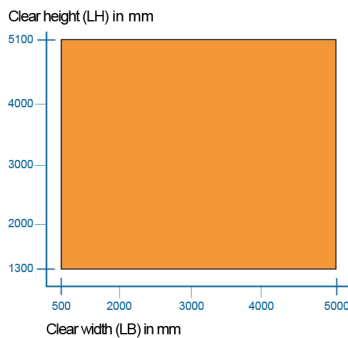
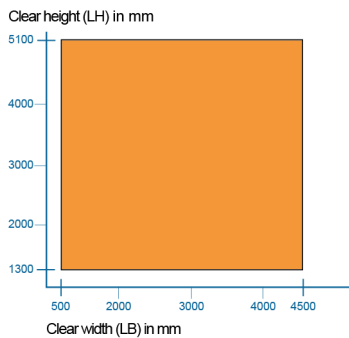

Fig. 3: Diagram of possible door system heights and widths for 290 R, 291 R, 292 R and 340 R, 341 R, 342 R

There is only one side frame design. Each of the side frames has space for 3 springs.

Door system heights and widths

Door system type	Clear width (LB)	Clear height (LH)
290 R; 291 R; 292 R	500 – 5000 mm	1300 – 5100 mm
340 R; 341 R; 342 R	500 – 5000 mm	1300 – 5100 mm



Door system heights and widths

Door system type	Clear width (LB)	Clear height (LH)
320 R; 321 R; 322 R	500 – 4500 mm	1300 – 5100 mm
330 R; 331 R; 332 R	500 – 4500 mm	1300 – 5100 mm

Fig. 4: Diagram of possible door system heights and widths for 320 R; 321 R; 322 R and 330 R; 331 R; 332 R

2.3 Speeds

Door system type		Average speed (max. speed)		
		Opening speed	Closing speed with door light grid	Closing speed with safety edge and light barrier
290 R	EFA-SST® Premium	2.0 m/s (2.3 m/s)	1.00 m/s	-
291 R	EFA-SST® Eco	1.1 m/s (1.3 m/s)	1.00 m/s	0.6 m/s
292 R	EFA-SST® Basic	0.6 m/s (0.7 m/s)	-	0.6 m/s
320 R	EFA-STT® Premium	2.6 m/s (3.1 m/s)	1.00 m/s	-
321 R	EFA-STT® Eco	1.1 m/s (1.3 m/s)	1.00 m/s	0.6 m/s
322 R	EFA-STT® Basic	0.6 m/s (0.7 m/s)	-	0.6 m/s
	330 R EFA-STR [€] Premium	3.2 m/s (3.7 m/s)	1.00 m/s	-
	331 R EFA-STR [€] Eco	1.6 m/s (1.9 m/s)	1.00 m/s	0.6 m/s
	332 R EFA-STR [€] Basic	0.6 m/s (0.7 m/s)	-	0.6 m/s
	340 R EFA-SST [€] Classic Premium	2.0 m/s (2.3 m/s)	1.00 m/s	-
	341 R EFA-SST [€] Classic Eco	1.1 m/s (1.3 m/s)	1.00 m/s	0.6 m/s
	342 R EFA-SST [€] Classic Basic	0.6 m/s (0.7 m/s)	-	0.6 m/s

The speeds depend on the door system dimensions, particularly the door system height.

- Not available

Technical properties

Performance properties

2.4 Performance properties

Performance features in accordance with DIN EN 13241

Door system type	Specification	Door system width/size, other specifications	Value
290 R	Resistance to wind load in compliance with DIN EN 12424	$500 \text{ mm} \leq \text{LB} \leq 3300 \text{ mm}$	Class 4
291 R		$3301 \text{ mm} \leq \text{LB} \leq 4000 \text{ mm}$	Class 3
292 R		$4001 \text{ mm} \leq \text{LB} \leq 5000 \text{ mm}$	Class 2
	Resistance to water ingress in compliance with DIN EN 12425	-	Class 3
	Air permeability in compliance with DIN EN 12426	-	Class 3
	Airborne sound insulation in compliance with DIN EN ISO 717-1	Only for EFA-THERM® lath	Rw = 24 dB
	Thermal insulation in compliance with DIN EN 12428	Only for EFA-THERM® lath for 5000 mm × 5100 mm	U = 1.40 W/m²K

npd = no performance determined

Door system type	Specification	Door system width/size, other specifications	Value
320 R	Resistance to wind load in compliance with DIN EN 12424	$500 \text{ mm} \leq \text{LB} \leq 3500 \text{ mm}$	Class 4
321 R		$3501 \text{ mm} \leq \text{LB} \leq 4250 \text{ mm}$	Class 3
322 R		$4251 \text{ mm} \leq \text{LB} \leq 4500 \text{ mm}$	Class 2
	Resistance to water ingress in compliance with DIN EN 12425	-	Class 0
	Air permeability in compliance with DIN EN 12426	-	Class 2
	Airborne sound insulation in compliance with DIN EN ISO 717-1	-	Rw = 20 dB
	Thermal insulation in compliance with DIN EN 12428	Only for EFA-CLEAR® transparent lath for 4500 mm × 5100 mm	U = 6.40 W/m²K

npd = no performance determined

Technical properties

Fire performance

Door system type	Specification	Door system width/size, other specifications	Value
330 R	Resistance to wind load in compliance with DIN EN 12424	$500 \text{ mm} \leq \text{LB} \leq 2750 \text{ mm}$	Class 4
331 R		$2751 \text{ mm} \leq \text{LB} \leq 3500 \text{ mm}$	Class 3
332 R		$3501 \text{ mm} \leq \text{LB} \leq 4100 \text{ mm}$	Class 2
		$4101 \text{ mm} \leq \text{LB} \leq 4500 \text{ mm}$	Class 1
	Resistance to water ingress in compliance with DIN EN 12425	-	Class 0
	Air permeability in compliance with DIN EN 12426	-	Class 1
	Airborne sound insulation in compliance with DIN EN ISO 717-1	-	Rw = 12 dB
	Thermal insulation in compliance with DIN EN 12428	Standard door leaf for 4500 mm × 5100 mm	U = 6.0 W/m ² K

npd = no performance determined

Door system type	Specification	Door system width/size, other specifications	Value
340 R	Resistance to wind load in compliance with DIN EN 12424	$500 \text{ mm} \leq \text{LB} \leq 5000 \text{ mm}$	Class 5 (+1050 Pa / -1050 Pa)
341 R			
342 R	Resistance to water ingress in compliance with DIN EN 12425	-	Class 0
	Air permeability in compliance with DIN EN 12426	-	Class 2
	Airborne sound insulation in compliance with DIN EN ISO 717-1	-	Rw = 25 dB
	Thermal insulation in compliance with DIN EN 12428	Only for EFA-ALUX® lath for 5000 mm × 5100 mm	U = 5.70 W/m ² K

npd = no performance determined

2.5 Fire performance

Fire performance as per DIN 4102

Indication	Value
Material class	B2 normally inflammable

Technical properties

Performance

2.6 Safety standards

Applicable regulations, safety standards and directives

The following regulations, standards and directives were taken into account in planning, engineering and production:

Regulations

EUV 305/2011	REGULATION (EU) NO. 305/2011 OF THE EUROPEAN PARLIAMENT AND THE COUNCIL OF 9 March 2011 laying down harmonised conditions for the marketing of construction products and repealing Council Directive 89/106/EEC
--------------	---

Directives

2006/42/EC	DIRECTIVE 2006/42/EC OF THE EUROPEAN PARLIAMENT AND COUNCIL of 17 May 2006 on machinery, and amending Directive 95/16/EC
2014/30/EU	DIRECTIVE 2014/30/EU OF THE EUROPEAN PARLIAMENT AND COUNCIL of 26 February 2014 on harmonisation of the laws of the member states relating to electromagnetic compatibility
2014/53/EU	DIRECTIVE 2014/53/EU OF THE EUROPEAN PARLIAMENT AND OF THE COUNCIL of 16 April 2014 on the harmonisation of the laws of the Member States relating to the making available on the market of radio equipment and repealing Directive 1999/5/EC

Standards

DIN EN 13241	Doors – Product standard, performance characteristics
DIN EN ISO 13849-1	Safety of machinery – Safety-related parts of control systems – Part 1 General principles for design
DIN EN ISO 13849-2	Safety of machinery – Safety-related parts of control systems – Part 2 Validation
DIN EN ISO 12100	Safety of machinery – General principles for design – Risk assessment and risk reduction

2.7 Performance

Door system type	Load cycles per year	Life cycle
Premium	400,000	10 years
ECO	200,000	
Basic	150,000	

3 Construction of the high-speed spiral door

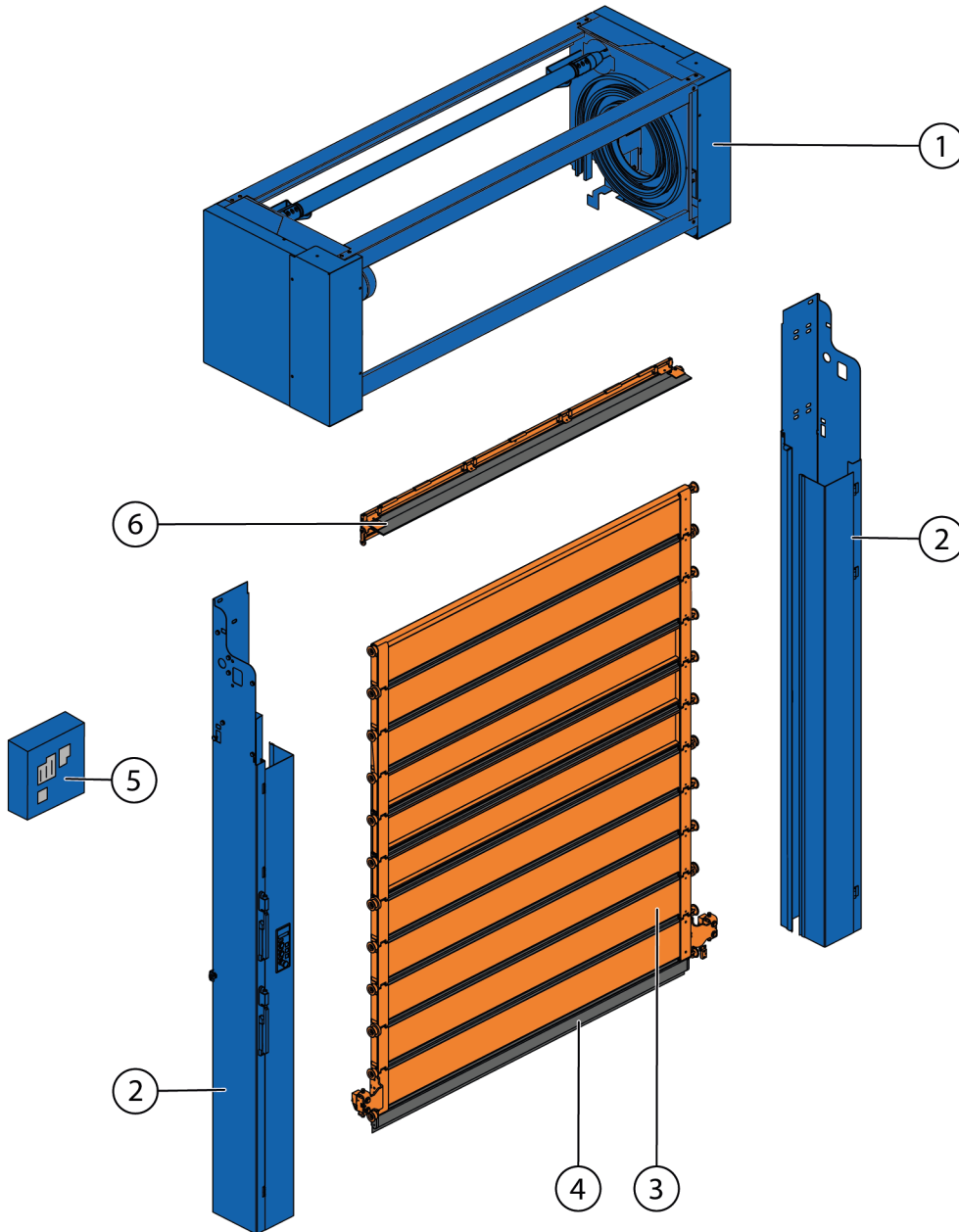

Fig. 5: Assemblies

Construction of the high-speed spiral door

1	Round spiral case (1) with main support, spiral guide, motor, drive shafts, synchronous shafts, bearings, reinforcement profiles, cover (optional)	<ul style="list-style-type: none"> ↳ Chapter 3.6 'Drives' on page 64 ↳ "Spiral case versions" on page 15
2	Side frames with vertical door leaf guide, weight counterbalance and door light grid	<ul style="list-style-type: none"> ↳ "Door leaf guide, side frame and side frame cover. Optional: Hinged side frame cover" on page 26 ↳ Chapter 3.1.1 'Transmission of force' on page 18 ↳ Chapter 3.2.1 'Counterbalance' on page 19 ↳ "Door light grid" on page 71
3	Door leaf	<ul style="list-style-type: none"> ↳ "Door leaf for door systems 290 R; 291 R; 292 R" on page 38 ↳ "Door leaf for door systems 320 R; 321 R; 322 R" on page 47 ↳ "Door leaf for door systems 330 R; 331 R; 332 R" on page 50 ↳ "Door leaf for door systems 340 R; 341 R; 342 R" on page 53
	Laths	↳ "Overview of the laths for door system" starting on page 39
4	Safety edge	↳ Chapter 4.1 'Safety edge and light barrier' on page 71
5	Control unit	↳ Chapter 3.7 'Control units' on page 64
6	Horizontal seal	↳ Chapter 3.5.1 'Seal for 290 R; 291 R; 292 R; 320 R; 321 R; 322 R; 340 R; 341 R; 342' on page 61
		↳ Chapter 3.5.2 'Seal on 330 R; 331 R; 332 R' on page 63



The high-speed spiral door has a symmetrical design. As a result, we always refer to an "operator side". The operator side has the controls such as the hand lever, EFA-HDI® etc. The operator side is important for the electrical supply cable for the control unit, if integrated.

3.1 Spiral case

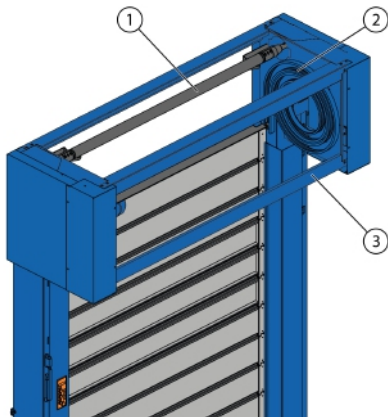

Fig. 6: Spiral case

The spiral case comprises:

- Synchronous shaft with bearing (item 1)
- Bevelled main supports with spiral guide on both sides (item 2)
- Sheet metal reinforcement profiles (item 3)

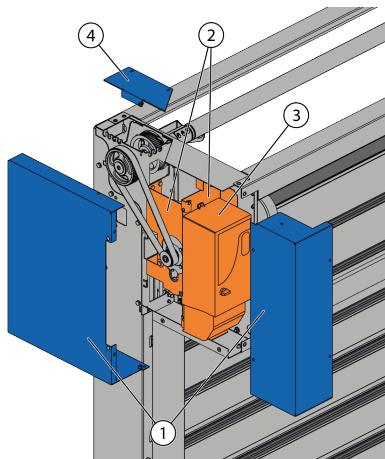

Fig. 7: Spiral case with console

Thanks to its open console construction (Fig. 7/2) the spiral case provides optimum accessibility for maintenance and repairs. The consoles have two easy-to-remove covers on each side (Fig. 7/1). A further cover is fitted on the upper side for adjustment or maintenance of the belt system (Fig. 7/4).

The front console cover can be detached separately, providing access to the EFA-TRONIC® control unit (Fig. 7/3).

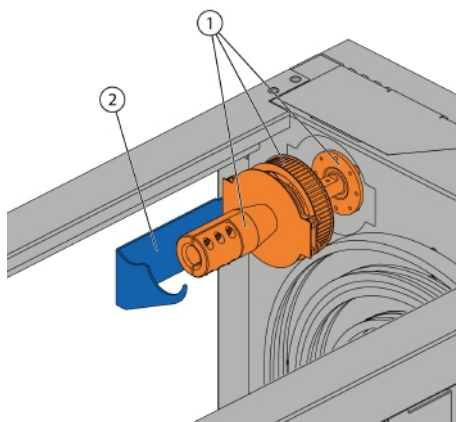

Fig. 8: Mounting aid and main bearing



Protecting against falling is still required during installation.

Construction of the high-speed spiral door

Spiral case

Spiral case cover (optional)

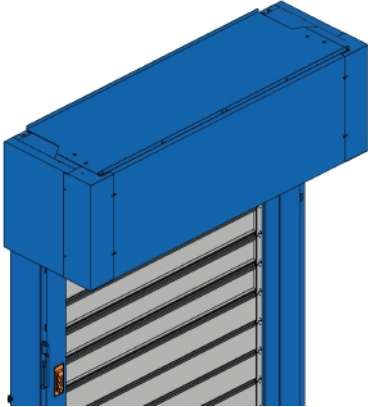

Fig. 9: Complete spiral case cover with sheet metal profile

The spiral case can optionally be covered at the bottom, front and top. The covers may reduce the clear height.



The cover on the spiral case as finger protection is mandatory for door systems with a height of less than 2500 mm.

With the complete spiral case cover with sheet metal profile the clear height restriction is 42 mm.

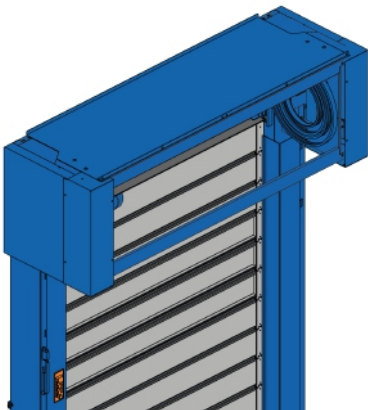

Fig. 10: Top only spiral case cover with sheet metal profile

With the top only spiral case cover with sheet metal profile the clear height restriction is 0 mm.

Construction of the high-speed spiral door

Spiral case

With the bottom and front spiral case cover with sheet metal profile the clear height restriction is 42 mm.

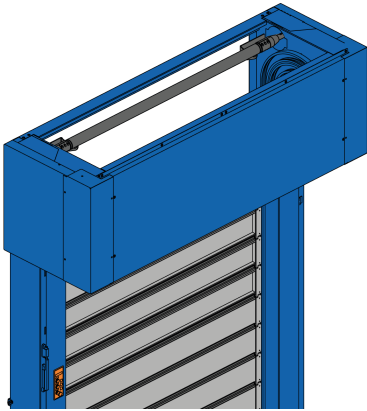

The lower sheet metal profile has two inspection openings, which can be opened if necessary for maintenance purposes.

Fig. 11: Bottom and front spiral case cover with sheet metal profile

Spiral case covers	Clear height restriction	Hinged side frame cover
Top only	-	available
Bottom and front	42 mm	available
Complete	42 mm	available

Construction of the high-speed spiral door

Side frames

3.1.1 Transmission of force

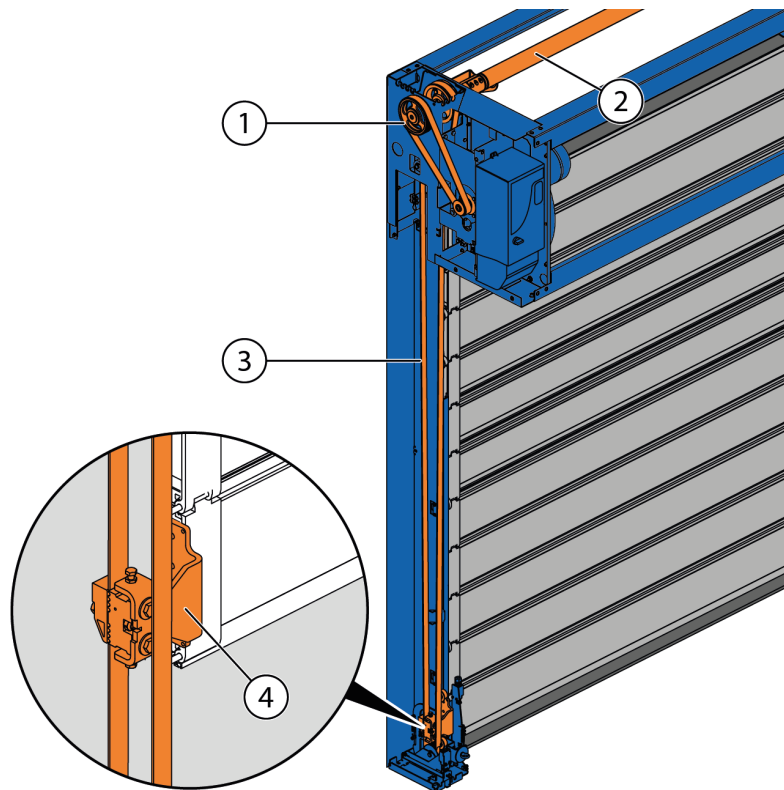

Fig. 12: Transmission of force

Force is transmitted from the drive to the door leaf by the drive chain (Fig. 12/1), synchronous shaft (Fig. 12/2), the continuous chains (Fig. 12/3) and the door leaf mounts (Fig. 12/4). Unlike a chain, the toothed belt runs very quietly.

The door leaf mounts are situated on the right and left-hand sides of the door leaf and are screwed to the hinge chains and the lowest lath of the door leaf (bottom lath). The hinge chains on both sides of the door system connect the bottom lath to the other laths. When the door leaf moves, the force is only applied to the bottom lath. All the other laths are fastened to the hinge chain and are moved at the same time without the effect of force.

3.2 Side frames

The side frames consist of the following components:

- Side frame: Bevelled sheet metal (steel or stainless steel)
- Side frame cover: Bevelled sheet metal (steel or stainless steel)
- Floor plate: Bevelled sheet metal (steel or stainless steel)
- Vertical guide: Bevelled sheet metal (steel or stainless steel) with screwed-on aluminium guide profiles

The shape of the side frame has been optimised to allow two different side frame cover designs.

Designs

- Fixed
 - Special features: Classic, cost-optimised design
- Hinged with internal hinges
 - Special features: Excellent accessibility for maintenance and improved look due to internal hinges

3.2.1 Counterbalance

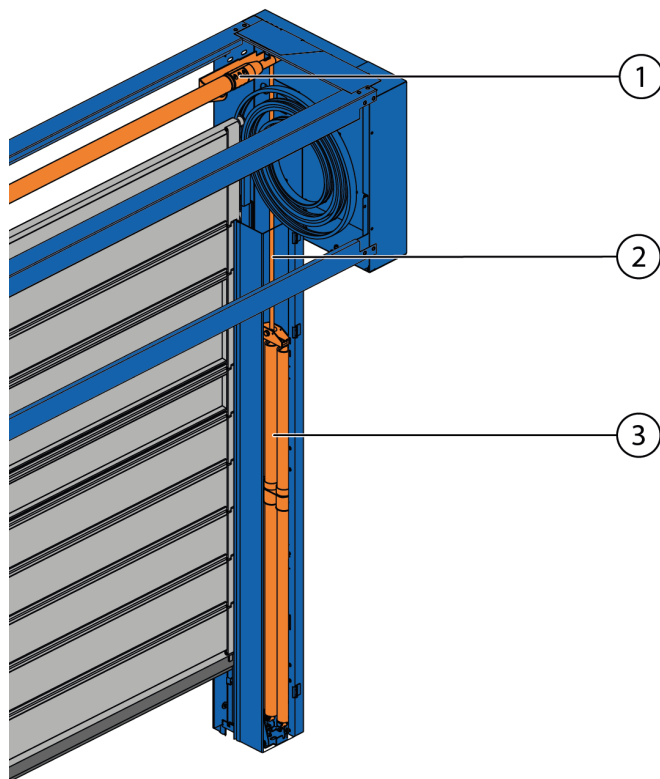

Fig. 13: Counterbalance

The door leaf is counterbalanced by a counter-pull mechanism: Tension springs (Fig. 13/3) are installed in the side frames (Fig. 13/2). The tension springs are connected to the synchronous shaft (Fig. 13/1) by heavy-duty belts. The tension springs are tensioned when the door system is closed and relaxed when the door system is open.

This enables the door system to be opened manually in case of a power failure. In normal mode the motor is assisted by the force of the tension springs.

The spring tension is calculated on an order-specific basis.

Construction of the high-speed spiral door

Side frames > Manual release lever

3.2.2 Manual release lever



Fig. 14: Manual release lever on the side frame (left) and on a separate console (right)

The manual release lever is situated on the side frame or optionally on a separate console. When the lever is pulled gently, the motor brake is released and the door leaf is lifted by the spring counterbalance. The door system can be opened completely by pushing the door leaf upwards manually. The control unit is in EMERGENCY STOP condition while doing this. The manual release lever is not designed for regular opening of the door system and does not have a catch position.

The manual release lever is also available in a lockable design (optional).

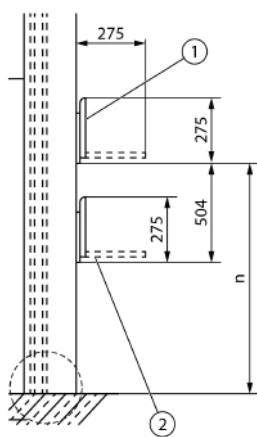

- 1 Manual release lever
- 2 Optional locking mechanism

n	Dimensions
1455 mm	1915 mm ≤ LH ≤ 5100 mm
LH - 460 mm	1300 mm ≤ LH ≤ 1914 mm

LH = Clear height

Fig. 15: Position of manual release lever

3.2.3 Door locking mechanism

Manual door locking mechanism (optional)

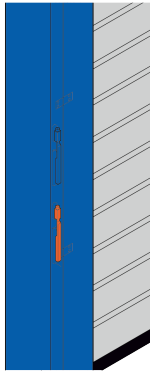

Fig. 16: Locking lever on side frame

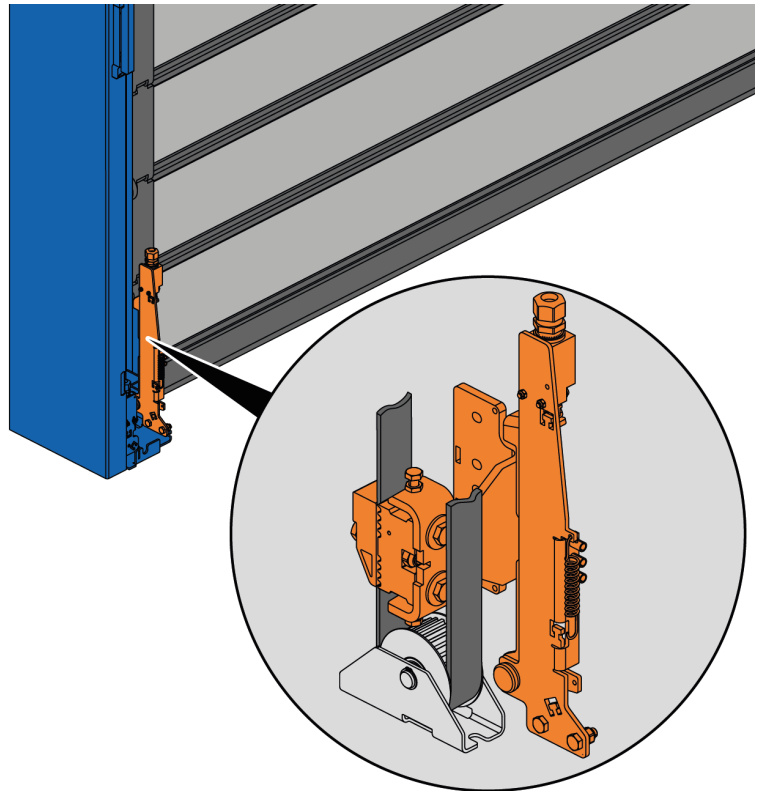

Fig. 17: Door locking mechanism in side frame

The mechanical locking mechanism is installed in the vertical side frame on the operator side. The locking mechanism handle keeps the door leaf closed so that it is safe from break-ins. The door locking mechanism is operated using a lever which is attached to the side frame or on an optional separate console.

Construction of the high-speed spiral door

Side frames > Door locking mechanism

The following versions are possible:

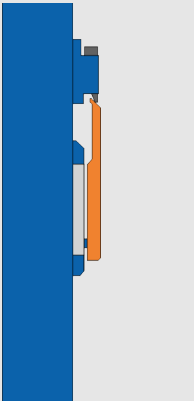
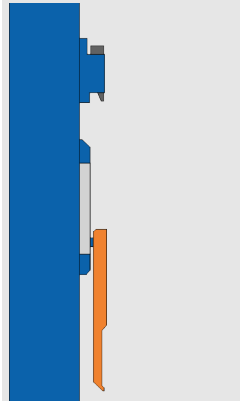
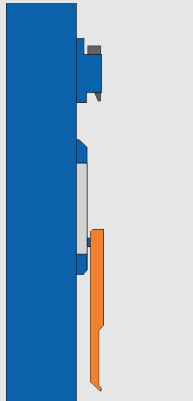
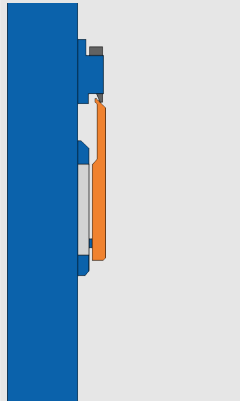
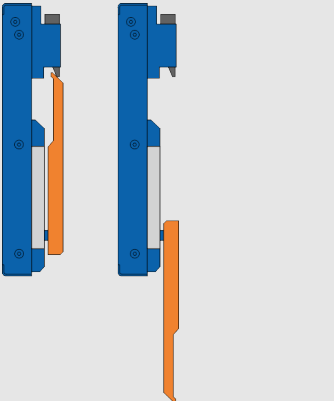
Standard version: Lever fitted to side frame		Optionally: Lever fitted to the side frame with reversed lever position		Optionally: Lever fitted to a separate console
Door leaf not locked	Door leaf locked	Door leaf not locked	Door leaf locked	
				
Lever position: Lever up	Lever position: Lever down	Lever position: Lever down	Lever position: Lever up	The lever position depends on laying of Bowden cable
Optional locking version			Optional locking version	Lever position up, optional locking version

Automatic door locking mechanism (optional)

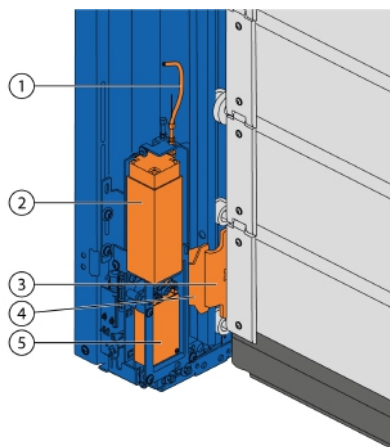

- 1 Bowden cable for emergency operation
- 2 Solenoid
- 3 Door leaf mount
- 4 Locking plate
- 5 Locking unit AV15 (AV18 and AV21 possible on request)

The automatic locking mechanism is installed in the vertical side frame on the operator side. A solenoid (Fig. 18/2) automatically moves the locking bolt into the counterpart (locking plate, Fig. 18/4 and Fig. 20/1) on the door leaf mount.



Because of the components on the door leaf mount (Fig. 18/3) the clear height (LH) has to be reduced by 80 mm with this option.

Fig. 18: Automatic door locking mechanism

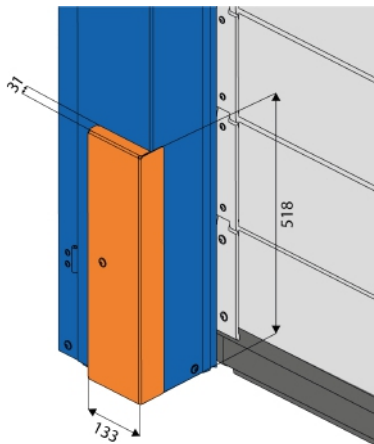

Fig. 19: Automatic door locking mechanism, dimensions

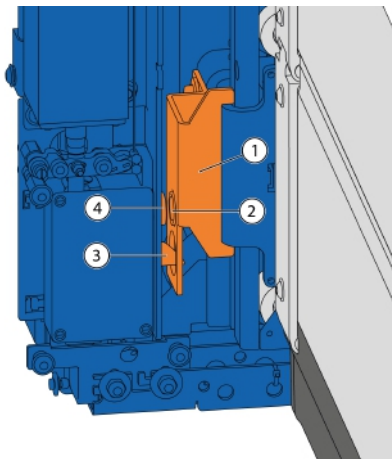

Fig. 20: Automatic door locking mechanism, permanent magnets

- 1 Locking plate
- 2 Permanent magnet on AV15 only
- 3 Locking bolt
- 4 Permanent magnet on AV15 only

Version AV15, with accidental locking protection

The accidental locking protection system uses two permanent magnets, which are opposite one another with the same poles when the door is closed and repel one another (Fig. 20/2 and Fig. 20/4). The magnet installed in the accidental locking protection system (Fig. 20/4) is permanently connected to a locking piece, which can be moved in an axial direction. This forcibly mechanically releases the locking bolt (Fig. 20/3), the locking mechanism contact is closed and the door leaf is locked. When the door is not closed, the magnets are not opposite one another. The locking bolt is thus forcibly and securely locked. The locking mechanism contact is open. In case of a fault (power failure), the locking mechanism contact always remains in open position and cannot be accidentally locked when the door system is open.

Version AV18 and AV21, without accidental locking protection system

The two permanent magnets are not fitted, which means that the locking bolt can be released in any door leaf position.

The AV18 and AV21 versions must be requested with a technical approval.

Construction of the high-speed spiral door

Side frames > Door locking mechanism

Door leaf locking with bolt

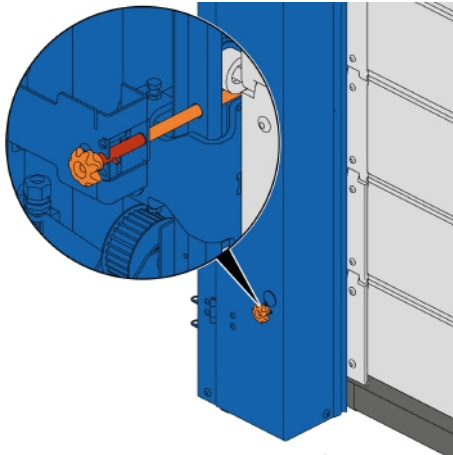

Door leaf locking with bolt is used:

- Only for trained specialist personnel as additional security for maintenance/repairs
- Only as additional security when cleaning the door system

Fig. 21: Door leaf locking with bolt



In the “Door closed” position, the bolt goes through the guide and thus blocks the rollers. When locked, the bolt is completely engaged in the side frame and the red part of the bolt is not visible.

Fig. 22: Door leaf locking with bolt, locked

Construction of the high-speed spiral door

Side frames > Door locking mechanism



If the red part of the bolt is visible, the door leaf is not locked.

Fig. 23: Door leaf locking with bolt, unlocked

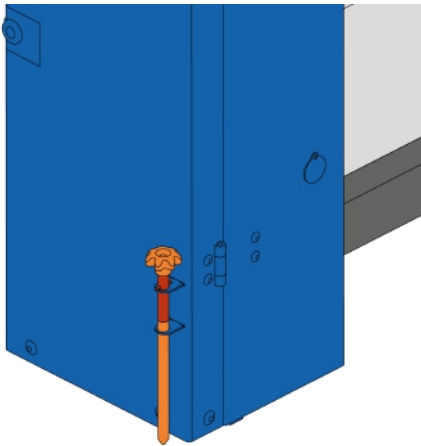

When the door system is being operated, the bolt is inserted into the side frame.

The opening for the bolt in the side frame cover is then closed using the rotating sheet metal cover.

Fig. 24: Door leaf locking with bolt, on side frame

Construction of the high-speed spiral door

Side frames > Door leaf guide

3.2.4 Door leaf guide

Door leaf guide, side frame and optional pivoting side frame cover

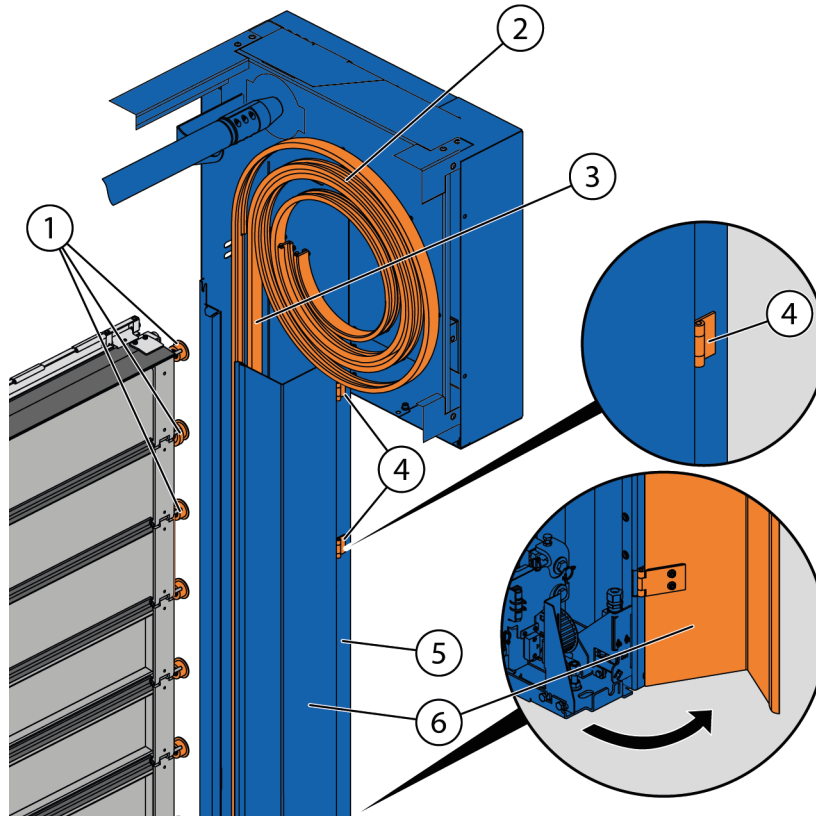

Fig. 25: Door leaf guide

The door leaf comprises laths which are connected by a hinge chain. Rollers (Fig. 25/1) are attached to the hinge chain. When the door system is opened and closed, the rollers are directed through the vertical (Fig. 25/3) and spiral-shaped (Fig. 25/2) door leaf guide. Very little noise is generated by the rolling of the rollers in the door leaf guide. The roller friction also ensures minimum wear on the rollers as no soiling is generated from abrasion. There is no wear on the door leaf itself. This gives the door system a long service life.

The vertical door leaf guides (Fig. 25/3) are made of sheet metal and aluminium profiles and are situated within the side frames (Fig. 25/5). Each side frame is made up of one main bevelled sheet metal profile and one bevelled sheet metal cover profile (Fig. 25/6). The sheet metal cover profiles are fastened with screws and can also be supplied in a pivoting design with hinges (Fig. 25/4).

For more information about this door-specific design option, see [table starting on page 16](#).

3.2.5 Side frame extension

The side frame extensions have the same construction as the side frames. In SAP, it is possible to freely configure whether one or two side frame extensions are required (depending on the installation situation). The type of side frame extension depends on the application or the design of the closing strip extension.



If “Stainless steel floor plate” is selected, only the lower floor plate of the side frame extension, which is on the floor, is made of stainless steel. The floor plate of the side frame is made of galvanised sheet metal.

Use	Shim plates	Side frame extension closed, Fig. 26	Side frame extension open, Fig. 27	Side frame extension with guide, Fig. 27
Compensation for floor level	≥ 4 mm to < 50 mm	≥ 50 mm	-	-
Flexible closing strip extension	≥ 30 mm to < 50 mm	≥ 50 mm	-	-
Rigid closing strip extension	≥ 30 mm to < 50 mm	-	≥ 50 mm to ≤ 109 mm	≥ 110 mm

- not possible

- The left and right side frame extensions can be selected independently in SAP in the range from 4 mm to 2500 mm.
- With the flexible closing strip extension the length of the side frame extension can be selected independently of the length of the closing strip extension.
- With the rigid closing strip extension the length of the side frame extension must be the same as or greater than the height of the closing strip extension.

Construction of the high-speed spiral door

Side frames > Flexible closing strip extension

Side frame extension closed

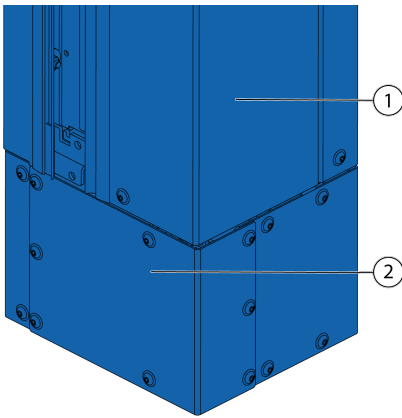

- 1 Side frame
- 2 Side frame extension without guide / closed

Fig. 26: Side frame extension closed

Side frame extension open

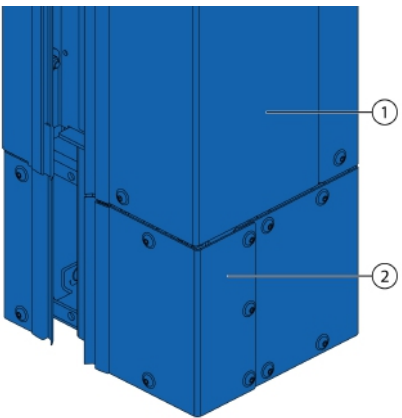

- 1 Side frame
- 2 Side frame extension with guide / open

Fig. 27: Side frame extension open

3.2.6 Flexible closing strip extension

If the floor is uneven, slanted or lower than the installation level of the side frames, the lower closing strip can be extended. This is done using a flexible PES fabric, which is pre-fitted on the lower closing strip based on the SAP configuration specifications.

Construction of the high-speed spiral door

Side frames > Flexible closing strip extension

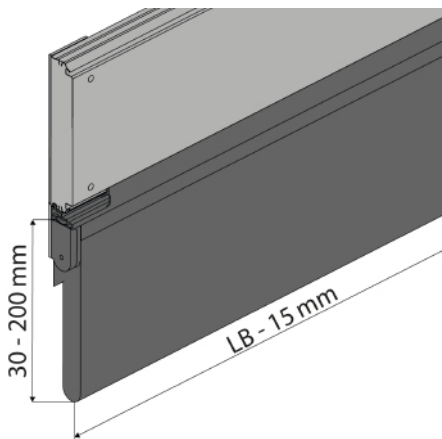

On door system types 290 R, 291 R, 292 R, 330 R, 331 R and 332 R the extension is inserted into grooves using keder profiles (Fig. 28).

On door system types 320 R, 321 R, 322 R, 340 R, 341 R and 342 R the extension is attached using aluminium strips.

This design is possible with or without a side frame extension (without guide / closed). The flexible side frame extension is always narrower than the clear width (LB) – 15 mm.

Fig. 28: Flexible closing strip extension – straight

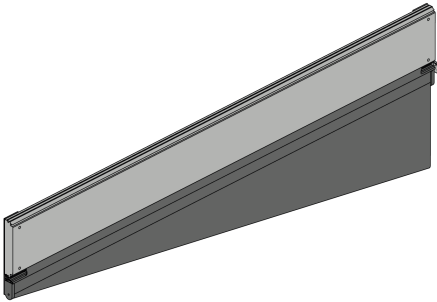

Fig. 29: Flexible closing strip extension – slanted

Possible flexible extension design

Length	30 mm – 200 mm
Material	PES fabric (0.8 mm thick material, polyester fabric coated with PVC), smooth on both sides, black
Shape	Straight extension Slanted extension to left or right
Safety	Secured by door light grid and safety edge
Restrictions	All performance features apart from “Resistance to wind load” are specified as “npd”

Construction of the high-speed spiral door

Side frames > Rigid closing strip extension

3.2.7 Rigid closing strip extension

If the floor is slanted or lower than the installation level of the side frames, the lower closing strip can be extended.

This design is only possible with a side frame extension.

A design without side frame extension must be requested with a technical approval.

The basis for the closing strip extension is a double-walled EFA-CLEAR® transparent lath with aluminium sheet filling or an EFA-ALUX® lath with screwed-on, bevelled aluminium sheets.

At a length of ≥ 110 mm additional rollers are attached to the sides to minimise the load on the mechanical assembly. As a result there are no restrictions in the "Resistance to wind load".

Possible rigid extension design on door system type 290 R, 291 R, 292 R

Length	30 mm – 400 mm	
	< 50 mm	Shim plates are supplied.
	≥ 50 mm	A side frame extension with guide / open is required. This is because the extension is always wider than the clear width. This means that in "Door closed" position there is no gap between the lower closing strip and the side frame extension.
Material	EFA-CLEAR® double-walled transparent laths with aluminium sheet filling. The aluminium sheets used in the thermally separated profiles (adhesive connection) are straight or slanted depending on the SAP configuration. This produces the required shape.	
Finish	E6/EV1, optional wet coating as per RAL according to SAP	
Shape	Straight extension	
	Slanted extension to left or right	
Safety	Secured by door light grid and safety edge	
Restrictions	All performance features apart from "Resistance to wind load" are specified as "npd"	

Possible rigid extension design on door system types 320 R, 321 R, 322 R, 330 R, 331 R, 332 R, 340 R, 341 R, 342 R

Length	30 mm – 400 mm	
	< 50 mm	Shim plates are supplied.
	≥ 50 mm	A side frame extension with guide / open is required. This is because the extension is always wider than the clear width. This means that in "Door closed" position there is no gap between the lower closing strip and the side frame extension.
Material	EFA-ALUX® lath with screwed-on, bevelled aluminium sheets. The aluminium sheets are straight or slanted, depending on the SAP configuration. This produces the required shape.	

Finish	E6/EV1, optional powder coating as per RAL according to SAP (exception 330 R, 331R, 332 R)
Shape	Straight extension
	Slanted extension to left or right
Safety	Secured by door light grid and safety edge
Restrictions	All performance features apart from "Resistance to wind load" are specified as "npd"

Straight design

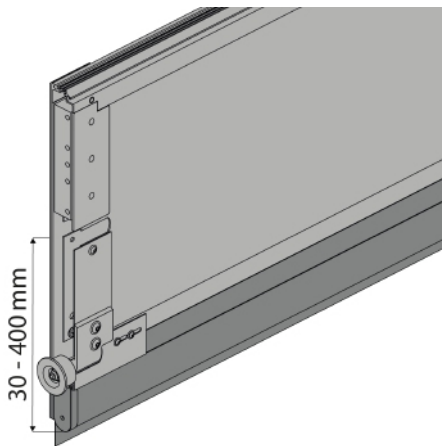

A straight extension can compensate for a difference of 30 mm – 400 mm.

Fig. 30: Straight design

Slanted extension

A slanted extension can compensate for a difference of 30 mm – 400 mm. The left and right side can be configured independently in SAP.

3.2.8 End positions

The following limit switches can be integrated into the door system:

- Inductive sensor – Pepperl & Fuchs NJ15, see ↪ page 32
- Transponder-coded safety limit switch – Euchner CES, see ↪ page 33
- Roller lever limit switch – Schmersal ZV7H, ↪ page 34

Note that simultaneous selection of limit switches and EFA-SCAN® is not possible due to space restrictions.

Construction of the high-speed spiral door

Side frames > End positions

Inductive sensor – Pepperl & Fuchs NJ15

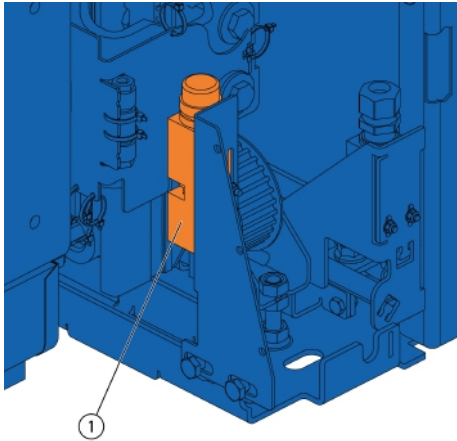

Application	“Door closed” and/or “Door open” message
Default	Customer/owner
Evaluation	Customer/owner
Safety category	none
Special feature	none

Fig. 31: “Door closed” inductive sensor

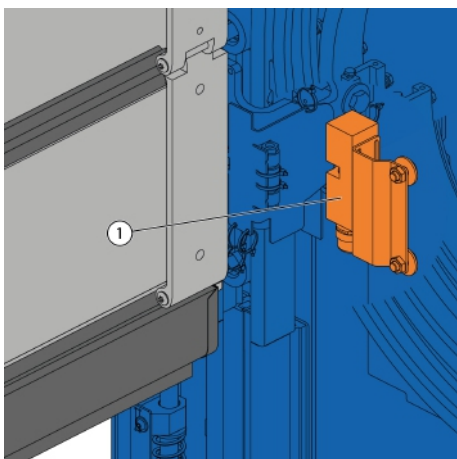
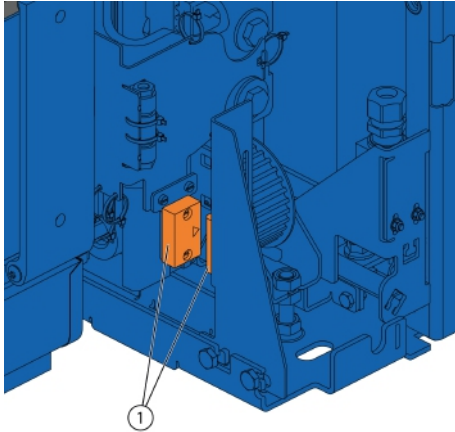

Fig. 32: “Door open” inductive sensor

Transponder-coded safety limit switch – Euchner CES



Application	“Door closed” and/or “Door open” safe message
Default	Customer/owner
Evaluation	Customer/owner
Safety category	Cat. 4/PL “e” (category, performance level) according to DIN EN ISO 13849-1
Special feature	External evaluation unit integrated in EFAFLEX control unit

Fig. 33: “Door closed” transponder-coded safety limit switch

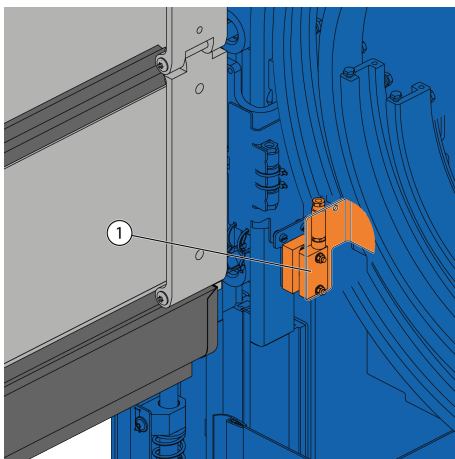
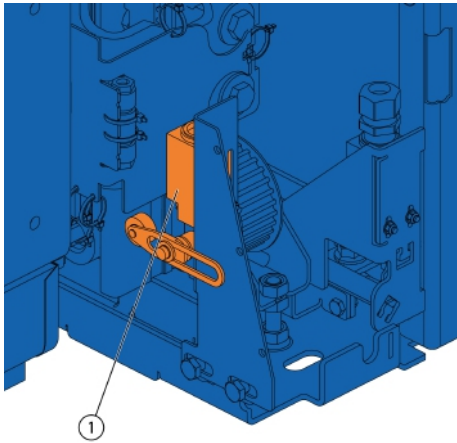

Fig. 34: “Door open” transponder-coded safety limit switch

Construction of the high-speed spiral door

Side frames > End positions

Roller lever limit switch – Schmersal ZV7H



Application	“Door closed” and/or “Door open” message
Default	Customer/owner
Evaluation	Customer/owner
Safety category	none
Special feature	The status message can be detected without voltage.

Fig. 35: “Door closed” roller lever limit switch

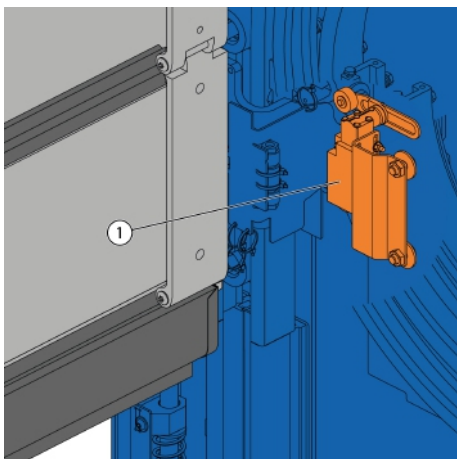
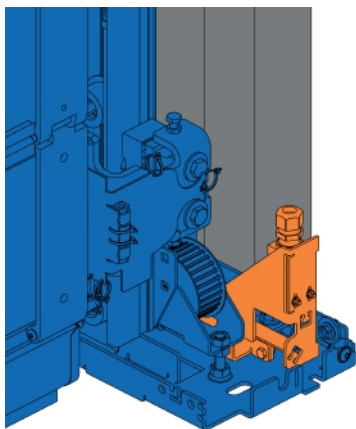

Fig. 36: “Door open” roller lever limit switch

3.2.9 Spring or belt break detector



The spring or belt break detector (Fig. 37) is integrated into the left and right side frame and increases the safety of the door system. It detects a break in the spring or belt and reports this to the control unit.

Fig. 37: Spring or belt break detector

3.3 Resistance class

Resistance class 2 (RC2) as defined in DIN V ENV 1627:1999-04 and (RC2) as defined in DIN/TS 18194:2020

After each complete closure to “Door closed” position and subsequent operation of the door locking mechanism (↗ ‘Manual door locking mechanism (optional)’ on page 21) the listed door system designs achieve resistance class 2:

- 290 R, 291 R, 292 R
- 320 R, 321 R, 322 R
- 340 R, 341 R, 342 R

With the “automatic locking mechanism” option no manual intervention is necessary to achieve resistance class 2 in “Door closed” position.

Resistance class 2 is only achieved if the door leaf is in the “Door closed” position and the locking mechanism is operated at the same time – i.e. the door leaf is locked.

Resistance class 2 means that an opportunist with simple tools such as screwdrivers, pliers and wedges cannot break (open or penetrate) the door system within three minutes.

The following equipment is applicable for the 290 R, 291 R, 292 R:

- EFA-THERM® lath with 0.4 mm steel plate (↗ ‘Structure of the EFA-THERM® lath’ on page 39)
- Emergency operation device on side frame, lockable
- Locking mechanism on side frame or automatic locking mechanism
- No EFA-VENT® ventilation laths
- One single-walled EFA-CLEAR® transparent lath with SAN filling, the rest EFA-THERM® laths

Construction of the high-speed spiral door

Resistance class

- Combination of:
 - One single-walled EFA-CLEAR® transparent lath with SAN filling
 - One EFA-THERM® lath
 - One single-walled EFA-CLEAR® transparent lath with SAN fillingTwo single-walled EFA-CLEAR® transparent laths with SAN filling must not be positioned directly above one another. There must be at least one EFA-THERM® lath in between.
- Combination of:
 - Maximum four single-walled EFA-CLEAR® transparent laths with hard polycarbonate filling
 - One EFA-THERM® lath
 - Four single-walled EFA-CLEAR® transparent lath with hard polycarbonate fillingA maximum of four single-walled EFA-CLEAR® transparent laths with hard polycarbonate filling can be positioned directly above one another. There must be at least one EFA-THERM® lath in between.
- One double-walled EFA-CLEAR® transparent lath with SAN filling, the rest EFA-THERM® laths
- Combination of:
 - One EFA-THERM® lath
 - One double-walled EFA-CLEAR® transparent lath with SAN fillingTwo double-walled EFA-CLEAR® transparent laths with SAN filling must not be positioned directly above one another. There must be at least one EFA-THERM® lath in between.
- Combination of:
 - Maximum four double-walled EFA-CLEAR® transparent laths with hard polycarbonate filling
 - One EFA-THERM® lath
 - Maximum four double-walled EFA-CLEAR® transparent laths with hard polycarbonate fillingNo more than four double-walled EFA-CLEAR® transparent laths with hard polycarbonate filling are to be positioned directly above one another. There must be at least one EFA-THERM® lath in between.

The following equipment is applicable for the 320 R, 321 R, 322 R:

- Single-walled EFA-CLEAR® transparent laths with SAN filling, hard polycarbonate filling or aluminium sheet filling
- Emergency operation device on the side frame, lockable
- Locking mechanism on side frame or automatic locking mechanism
- No EFA-VENT® ventilation laths

- Combination of:
 - One EFA-CLEAR® transparent with SAN filling
 - One single-walled EFA-CLEAR® transparent lath with aluminium sheet filling
 - One single-walled EFA-CLEAR® transparent lath with SAN fillingTwo single-walled EFA-CLEAR® transparent laths with SAN filling must not be positioned directly above one another. There must be at least one single-walled EFA-CLEAR® transparent lath in between.
- Combination of:
 - Maximum four single-walled EFA-CLEAR® transparent laths with hard polycarbonate filling
 - One single-walled EFA-CLEAR® transparent lath with aluminium sheet filling
 - Four single-walled EFA-CLEAR® transparent lath with hard polycarbonate fillingA maximum of four single-walled EFA-CLEAR® transparent laths with hard polycarbonate filling can be positioned directly above one another. There must be at least one single-walled EFA-CLEAR® transparent lath in between.

The following equipment is applicable for the 340 R, 341 R, 342 R:

- EFA-THERM® laths with spacing of 151 mm or 225 mm
- Emergency operation device on side frame, lockable
- Locking mechanism on side frame or automatic locking mechanism
- No EFA-VENT® ventilation laths
- One single-walled EFA-CLEAR® transparent lath with SAN filling
- Combination of:
 - One EFA-ALUX® lath
 - One single-walled EFA-CLEAR® transparent lath with SAN filling
 - One EFA-ALUX® lathTwo single-walled EFA-CLEAR® transparent laths with SAN filling must not be positioned directly above one another. There must be at least one EFA-ALUX® lath in between.
- Combination of:
 - Maximum four single-walled EFA-CLEAR® transparent laths with hard polycarbonate filling
 - One EFA-ALUX® lath
 - Maximum four single-walled EFA-CLEAR® transparent laths with hard polycarbonate fillingNo more than four single-walled EFA-CLEAR® transparent laths with hard polycarbonate filling are to be positioned directly above one another. There must be at least one EFA-ALUX® lath in between.

Construction of the high-speed spiral door

Door leaf, laths and door leaf design > Door systems 290 R; 291 R; 292 R

In general:

- The use of a side frame extension must be examined on a case-by-case basis.
- The use of screw-through assembly must be examined on a case-by-case basis.

The door system type is listed in what is known as the “KPK list” (KPK: Kommission Polizeiliche Kriminalprävention; Commission for Crime Prevention), which can be accessed online via the Bavarian State Criminal Police Office. This KPK list records tested and certified burglar-resistant products and is updated twice a year as scheduled.



Fig. 38: Seal manufacturer directories

3.4 Door leaf, laths and door leaf design

3.4.1 Door systems 290 R; 291 R; 292 R

Door leaf

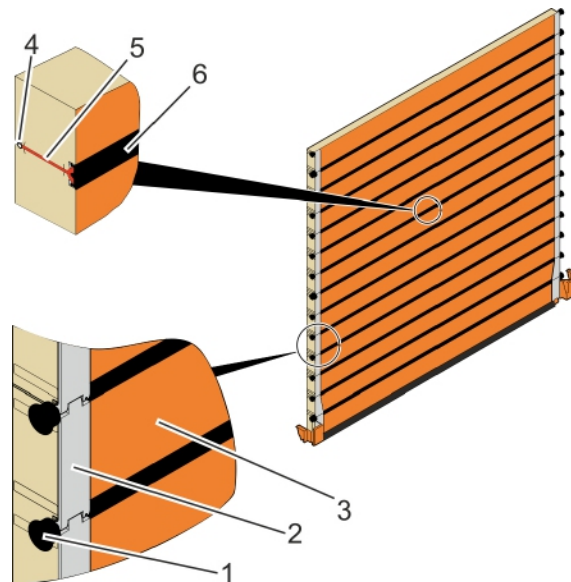

Fig. 39: Door leaf

Construction of the high-speed spiral door

Door leaf, laths and door leaf design > Door systems 290 R; 291 R; 292 R

Door system type	Thickness of the door leaf
290 R; 291 R; 292 R	40 mm

The door leaf is assembled from laths (Fig. 39/3) which are kept at the correct spacing by hinge chains (Fig. 39/2) attached at the sides. This spacing prevents contact between the laths. They are thus free from wear. The forces for opening and closing the door system are transmitted via hinges.

Ball-bearing mounted rollers (Fig. 39/1) keep the door leaf firmly in the guides in the horizontal direction. The laths are connected to one another by rubber hinges (Fig. 39/6) and O-profile seals (Fig. 39/4). An air cushion (Fig. 39/5) is created between. It provides similarly effective insulation as that of the laths.

This homogeneous door leaf construction ensures the very good running performance, the high running speed and the excellent U-value.

Structure of the EFA-THERM® lath

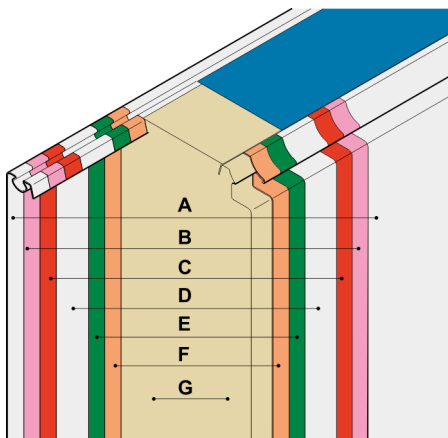

Fig. 40: Structure of the EFA-THERM® lath

The EFA-THERM® laths are structured with the following layers:

- A Top coat
- B Primer
- C Zinc layer 150 g/m²
- D Sheet metal (made of steel coil)
- E Zinc layer 150 g/m²
- F Adhesive
- G PU hard foam, 42 kg/m³, CFC and HCFC free

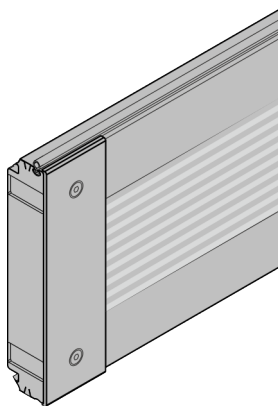
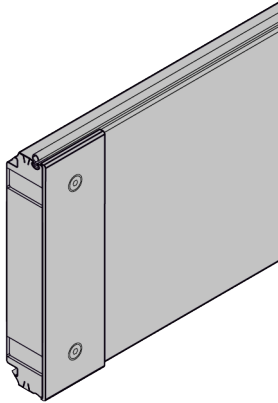

Fig. 41: EFA-THERM® lath with lining

Dimensions	40 × 222 mm
Material	Steel plate 0.4 mm
Finish	2 coats of paint
Colour	White aluminium, similar to RAL 9006 or grey aluminium, similar to RAL 9007
Optional	Wet lath coating Colours in compliance with SAP

Construction of the high-speed spiral door

Door leaf, laths and door leaf design > Door systems 290 R; 291 R; 292 R



Dimensions	40 × 222 mm
Material	Steel plate 0.4 mm
Finish	2 coats of paint
Colour	White aluminium, similar to RAL 9006 or grey aluminium, similar to RAL 9007
Optional	Wet lath coating Colours in compliance with SAP

Fig. 42: EFA-THERM® lath without lining, smooth finish

Closing strip

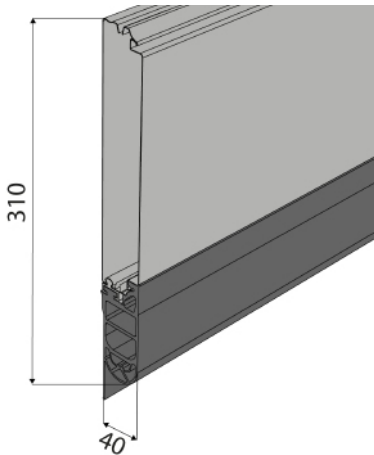

Construction	EFA-THERM® lath with adapter profile and rubber closing strip (floor seal)
Dimensions	40 × 310 mm
Adapter profile material/finish	Plastic/black, not coated

Fig. 43: Closing strip

Door system type 290 R; 291 R; 292 R

Sheet thickness	Material	Surface/colour		With or without lining
		Coil colour	RAL wet coating	
0.4 mm	Steel	9006	-	available
0.4 mm	Steel	9007	-	available
0.4 mm	Steel	-	as per SAP	available

Construction of the high-speed spiral door

Door leaf, laths and door leaf design > Door systems 290 R; 291 R; 292 R

EFA-CLEAR® transparent lath, double-walled (optional)

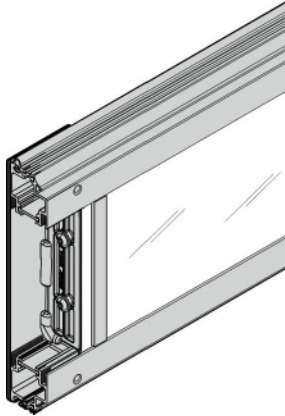

Fig. 44: EFA-CLEAR® transparent lath, double-walled

The EFA-CLEAR® double-walled, thermally insulated transparent laths are each comprised of two plastic panes which are pressed into aluminium profiles with spacing between the panes.

Dimensions	40 × 222 mm Viewing area height: Approx. 135 mm
Finish	E6/EV1 (natural anodised)
Glazing	SAN pane (transparent) Hard polycarbonate panes (scratch resistant, transparent) One SAN pane with frosted glass finish (opal) with 75% translucency, on outside of door leaf One transparent SAN pane on inside of door leaf
Optional	Wet coating for aluminium profiles Colours in compliance with SAP

The number of EFA-CLEAR® transparent laths is limited.

Construction of the high-speed spiral door

Door leaf, laths and door leaf design > Door systems 290 R; 291 R; 292 R

EFA-CLEAR® transparent lath, single-walled (optional)

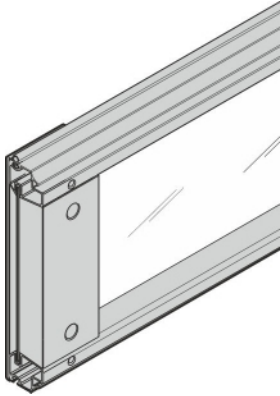

Fig. 45: EFA-CLEAR® transparent lath (single-walled)

The EFA-CLEAR® transparent laths comprise transparent plastic panes pressed into aluminium profiles.

Dimensions	40 × 222 mm Viewing area height: Approx. 155 mm
Finish	E6/EV1 (natural anodised)
Glazing	SAN panes (transparent) Hard polycarbonate panes (scratch resistant, transparent) SAN panes with frosted glass finish (opal) and 75% translucency
Optional	Wet coating for aluminium profiles Colours in compliance with SAP

The number of EFA-CLEAR® transparent laths is not limited.



In SAP, the entire door leaf (except for the top and bottom closing strip) can be selected with single-walled EFA-CLEAR® transparent laths. This gives the look and sound insulation figures of door system types 320 R, 321 R, 322 R, but with a 40 mm thick door leaf. The performance features such as air permeability and resistance to water ingress are then class 3, see



Performance features in accordance with DIN EN 13241' on page 10.

Construction of the high-speed spiral door

Door leaf, laths and door leaf design > Door systems 290 R; 291 R; 292 R

EFA-VENT® ventilation lath (optional)

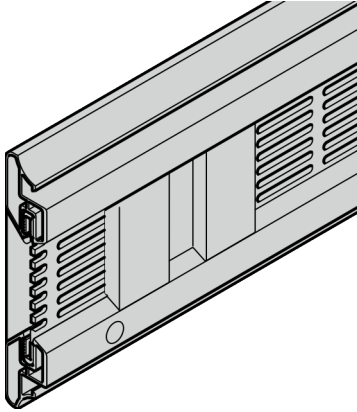

Fig. 46: EFA-VENT® ventilation lath

The EFA-VENT® ventilation laths comprise aluminium sheets with elongated holes (50 × 6 mm), which are pressed into aluminium profiles.

Dimensions	40 × 222 mm
Finish	Anodised E6/EV1
Vent cross-section (LA) in m ²	LA = ((LB-0.105) × 0.066) × number of laths LB = Clear width in metres
Optional	Wet coating of aluminium profiles and ventilation laths Colours in compliance with SAP

The number of EFA-VENT® ventilation laths is not limited.

LA1

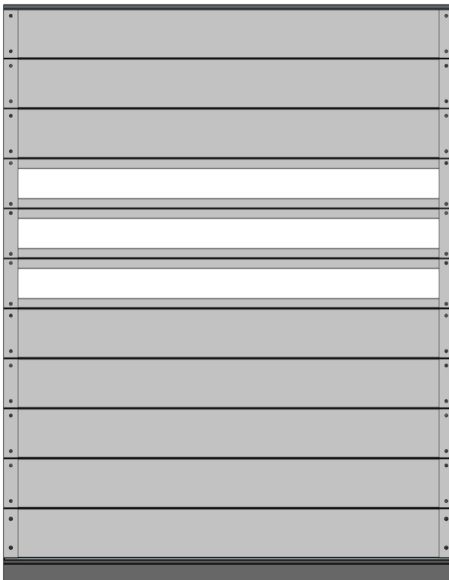

Fig. 47: Door leaf design LA1

View from the outside

- EFA-THERM® lath, steel sheet, surface similar to RAL 9006
- EFA-THERM® lath protective sheet (aluminium), surface E6/EV1 (natural anodised) and screws galvanised/stainless steel
- EFA-CLEAR® lath, single or double glazing or ventilation lath (aluminium), surface E6/EV1 (natural anodised) and screws galvanised/stainless steel

Construction of the high-speed spiral door

Door leaf, laths and door leaf design > Door systems 290 R; 291 R; 292 R

LA2

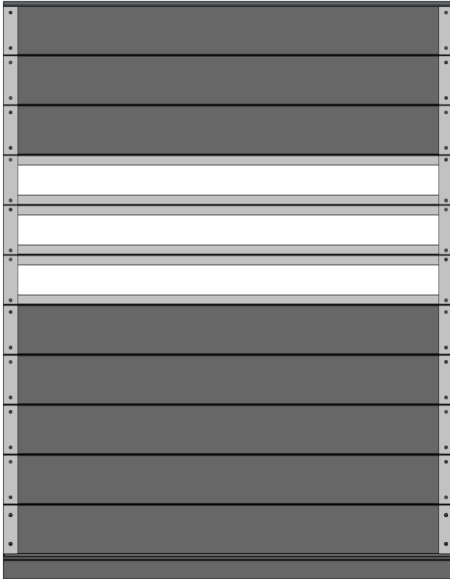

Exterior view

- EFA-THERM® lath steel sheet, surface similar to RAL 9007
- EFA-THERM® lath protection sheet metal (aluminium), surface E6/EV1 (naturally anodised) and galvanised screws/stainless steel
- EFA-CLEAR® lath single or double glazing or ventilation lath (aluminium), surface E6/EV1 (naturally anodised) and galvanised screws/stainless steel

Fig. 48: Door leaf version LA2

LA3

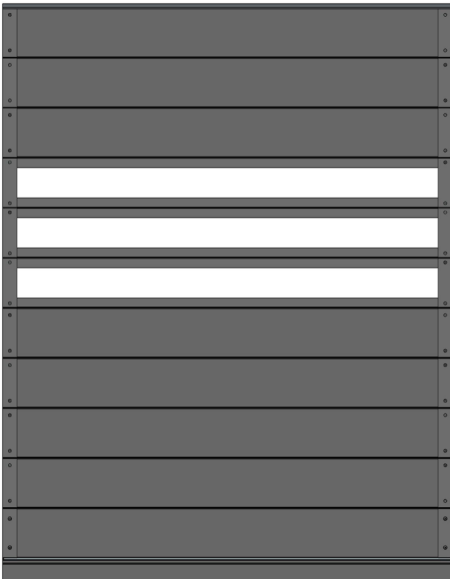

Exterior view

- EFA-THERM® lath steel sheet, surface similar to RAL 9007
- EFA-THERM® lath protection sheet metal (aluminium), and screws with wet paint similar to RAL 9007
- EFA-CLEAR® lath single or double glazing or ventilation lath (aluminium) with wet paint similar to RAL 9007

Fig. 49: Door leaf version LA3

Construction of the high-speed spiral door

Door leaf, laths and door leaf design > Door systems 290 R; 291 R; 292 R

LA4



Exterior view

- EFA-THERM® lath steel sheet, surface similar to RAL 9007
- EFA-THERM® lath protection sheet metal (aluminium), and screws with wet paint similar to RAL 9007
- EFA-CLEAR® lath single or double glazing or ventilation lath (aluminium), surface E6/EV1 (naturally anodised) and galvanised screws/stainless steel

Fig. 50: Door leaf version LA4

LA1 (interior)

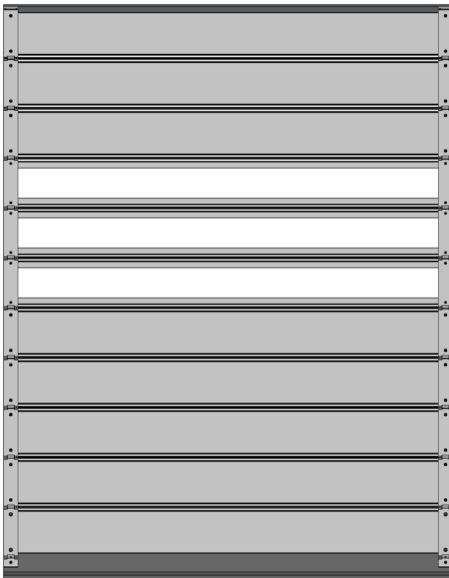

View from the inside

- EFA-THERM® lath, steel sheet, surface similar to RAL 9006
- Hinge chain (aluminium), surface E6/EV1 (natural anodised) and screws galvanised/stainless steel
- EFA-CLEAR® lath, single or double glazing or ventilation lath (aluminium), surface E6/EV1 (natural anodised) and screws galvanised/stainless steel

Fig. 51: Door leaf design LA1, interior

Construction of the high-speed spiral door

Door leaf, laths and door leaf design > Door systems 290 R; 291 R; 292 R

LA2 and LA4 (interior)

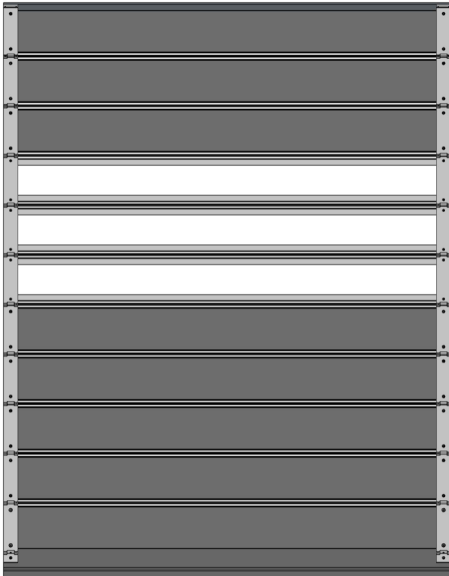

View from the inside

- EFA-THERM® lath, steel sheet, surface similar to RAL 9007
- Hinge chain (aluminium), surface E6/EV1 (natural anodised) and screws galvanised/stainless steel
- EFA-CLEAR® lath, single or double glazing or ventilation lath (aluminium), surface E6/EV1 (natural anodised) and screws galvanised/stainless steel

Fig. 52: Door leaf design LA2 and LA4, interior

LA3 (interior)

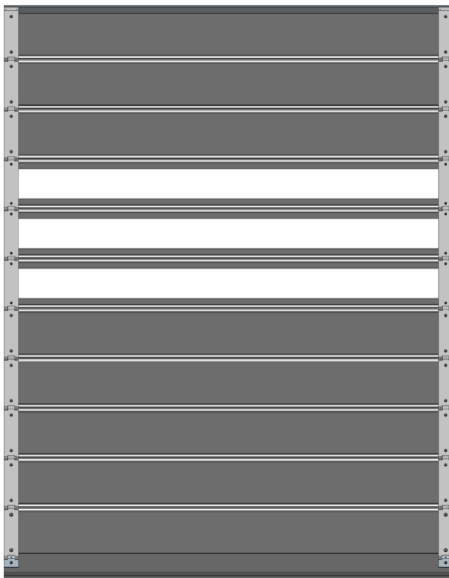

View from the inside

- EFA-THERM® lath, steel sheet, surface similar to RAL 9007
- Hinge chain (aluminium), surface E6/EV1 (natural anodised) and screws galvanised/stainless steel
- EFA-CLEAR® lath, single or double glazing or ventilation lath (aluminium) with wet varnish similar to RAL 9007

Fig. 53: Door leaf design LA3, interior

Construction of the high-speed spiral door

Door leaf, laths and door leaf design > Door systems 320 R; 321 R; 322 R

3.4.2 Door systems 320 R; 321 R; 322 R

Door leaf

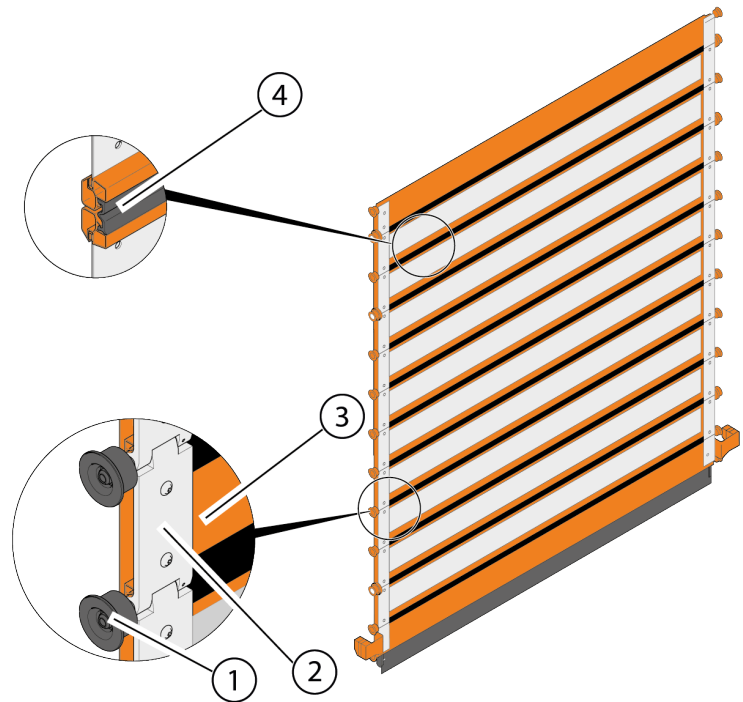

Fig. 54: Door leaf with 30 mm thick EFA-CLEAR® transparent laths and a spacing of 225 mm

Door system type	Thickness of the door leaf
320 R; 321 R; 322 R	30 mm

The door leaf is assembled from laths (Fig. 54/3) which are kept at the correct spacing by hinge chains (Fig. 54/2) attached at the sides. This spacing prevents contact between the laths. They are thus free from wear. The forces for opening and closing the door system are transmitted via hinges.

Ball-bearing mounted rollers (Fig. 54/1) keep the door leaf firmly in the guides in the horizontal direction. The laths are connected to each other by rubber hinges (Fig. 54/4).

The door leaf is equipped with 30 mm thick EFA-CLEAR® transparent laths with a spacing of 225 mm.

The tried and tested EFAFLEX door leaf design guarantees extremely quiet operation.

Construction of the high-speed spiral door

Door leaf, laths and door leaf design > Door systems 320 R; 321 R; 322 R

Closing strip

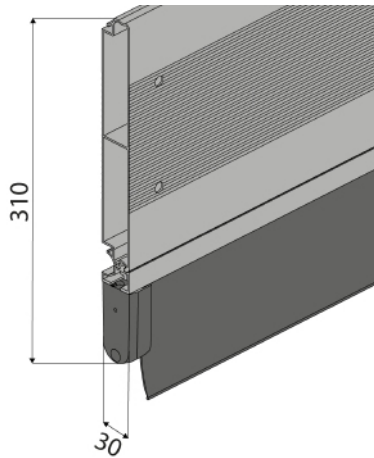

Construction	EFA-ALUX® lath with adapter profile and rubber closing strip (floor seal)
Dimensions	30 × 310 mm
Adapter profile material/finish	Aluminium, Eloxal E6/EV1 (natural anodised)
Optional	Powder coating for aluminium profiles Colours in compliance with SAP

Fig. 55: Closing strip

EFA-CLEAR® transparent lath, single-walled (optional)

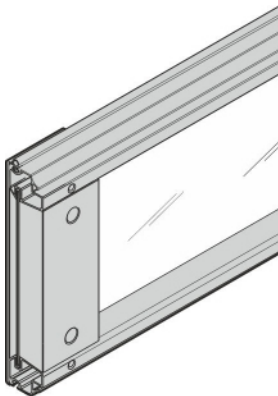

Fig. 56: EFA-CLEAR® transparent lath (single-walled)

The EFA-CLEAR® transparent laths comprise transparent plastic panes (optionally aluminium sheets) pressed into aluminium profiles.

Dimensions	30 × 222 mm Viewing area height: Approx. 155 mm
Finish	E6/EV1 (natural anodised)
Glazing	SAN panes (transparent) SAN panes (non-transparent, coloured aluminium grey) SAN panes with frosted glass finish and 75% translucency Hard polycarbonate panes (scratch resistant, transparent) Aluminium sheet E6/EV1, 2 mm thick
Optional	Powder coating for aluminium profiles Colours in compliance with SAP

Construction of the high-speed spiral door

Door leaf, laths and door leaf design > Door systems 320 R; 321 R; 322 R

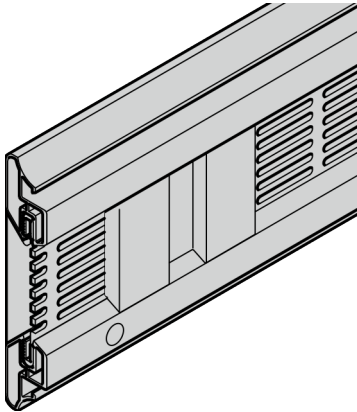

Fig. 57: EFA-VENT® ventilation lath

Door leaf design 320 R; 321 R; 322 R

Dimensions	30 × 222 mm
Finish	Anodised E6/EV1
Vent cross-section (LA) in m ²	LA = ((LB-0.105) × 0.066) × number of laths LB = Clear width in metres
Optional	Wet coating for aluminium profiles and ventilation sheets Colours in compliance with SAP

The door leaf always has an aluminium closing strip at the top and bottom. All combination options of the different laths can be selected in SAP.

It is only ever possible to combine two different lath designs with one another, for example SAN EFA-CLEAR® transparent laths and EFA-VENT® ventilation laths.

Construction of the high-speed spiral door

Door leaf, laths and door leaf design > Door systems 330 R; 331 R; 332 R

3.4.3 Door systems 330 R; 331 R; 332 R

Door leaf

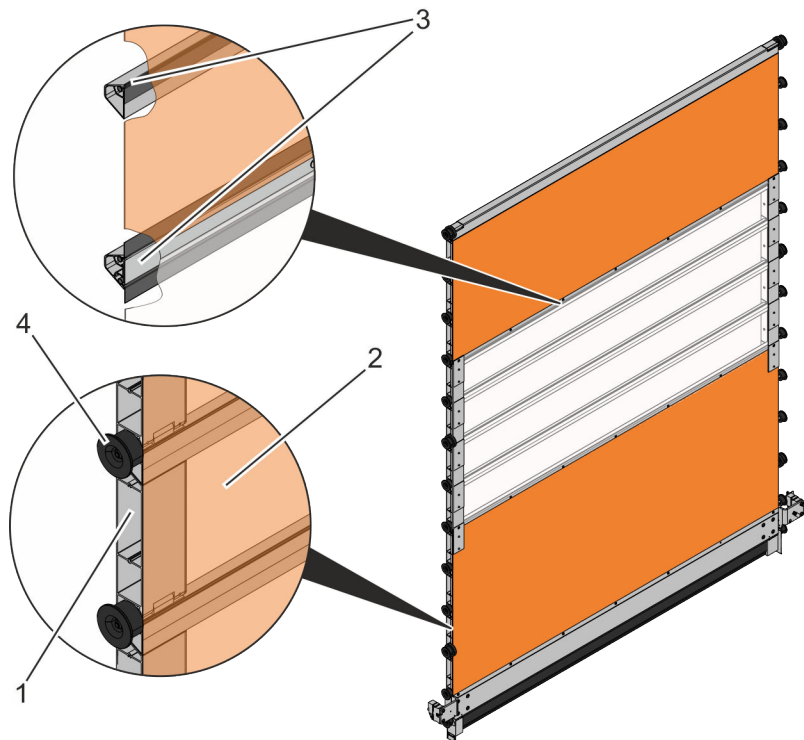

Fig. 58: Door leaf

Door system type	Thickness of the door leaf
330 R; 331 R; 332 R	40 mm

The door leaf is assembled from extruded aluminium profiles (keder profiles) which are kept at the correct spacing by hinge chains (Fig. 58/1) attached at the sides.

0.6 mm thick PVC-coated polyester fabric (PES fabric) (Fig. 58/2) is installed between the keder profiles as the filling.

Keder (Fig. 58/3) are welded to the PES fabric, thereby connecting the PES fabric and the keder profiles/laths.

These keder are mounted to fit snugly in the keder profiles and are therefore also taut and as wrinkle-free as possible.

This ensures the stability of the door leaf. The spacing created by the hinge chains prevents contact between the keder profiles/laths. They are thus free from wear. The forces for opening and closing the door system are transmitted via hinges. Ball-bearing mounted rollers (Fig. 58/4) keep the door leaf firmly in the guides in the horizontal direction.

This homogeneous door leaf construction ensures extremely good running performance, high running speed and good wind stability.

Construction of the high-speed spiral door

Door leaf, laths and door leaf design > Door systems 330 R; 331 R; 332 R

Door leaf versions

0.6 mm thick curtain made of PVC-coated polyester fabric (PES fabric), smooth on both sides.

The door leaf cover consists of different cover segments. These segments consist of at least 3 laths (675 mm) and a maximum of 9 laths (2025 mm). If required, different cover segments are combined in the door leaf.

- blue, similar to RAL 5002
- red, similar to RAL 3002
- yellow, similar to RAL 1021
- light grey, similar to RAL 7035
- orange, similar to RAL 2004
- Soft PVC viewing area, transparent
 - Min. 675 high (3 laths) or based on SAP configurator
 - Max. entire door leaf or based on SAP configurator
- Screen door area made of PVC-coated polyester fabric
 - Min. 675 high (3 laths) or based on SAP configurator
 - Max. entire door leaf or based on SAP configurator

Vent cross-section (LA) in m²

$LA = (LB - 0.109) \times 0.036 \times \text{number of laths}$
LB = Clear width in metres

Laths

In this product description, the term “lath” is used for a single or double keder profile, which is screwed into the hinge chain. Combined with the segments of the hinge chain, the profiles form a lath.

Double keder profiles are used for the transition from one cover segment to the next.

Examples

- Transition transparent to non-transparent
- Cover segment transition (different segment heights)

Construction of the high-speed spiral door

Door leaf, laths and door leaf design > Door systems 330 R; 331 R; 332 R

Closing strip

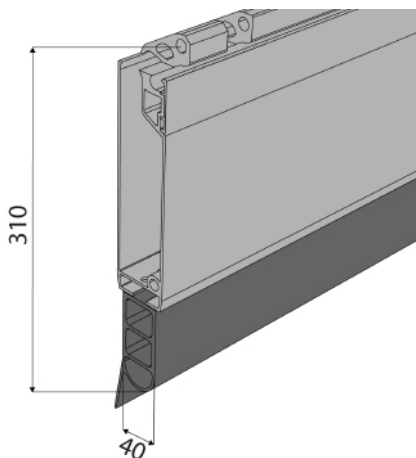

Fig. 59: Closing strip

The bottom closing strip comprises a double-walled anodised aluminium profile.

Construction	Aluminium profile and rubber closing strip (floor seal)
Dimensions	40 × 310 mm
Finish	E6/EV1 (natural anodised)

Single keder profile

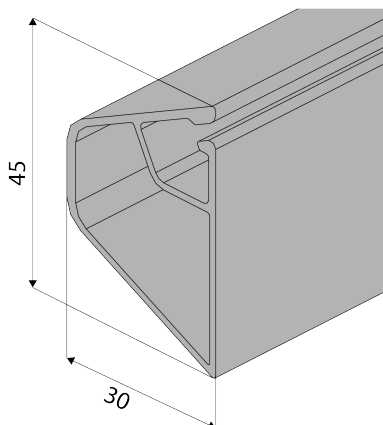

Fig. 60: Single keder profile

Door system type 330 R; 331 R; 332 R	
Dimensions of the keder	30 × 45 mm
Finish	E6/EV1 (natural anodised)

Construction of the high-speed spiral door

Door leaf, laths and door leaf design > Door systems 340 R; 341 R; 342 R

Double keder profile

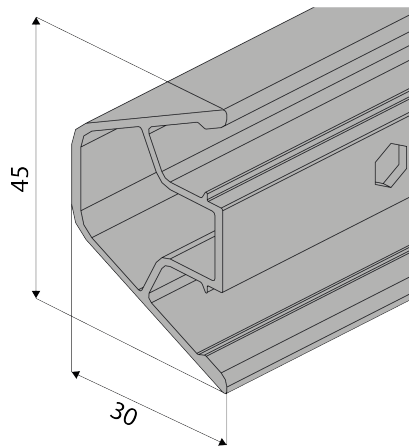

Door system type 330 R; 331 R; 332 R	
Dimensions of the keder	30 × 45 mm
Finish	E6/EV1 (natural anodised)

Fig. 61: Double keder profile

3.4.4 Door systems 340 R; 341 R; 342 R

Door leaf

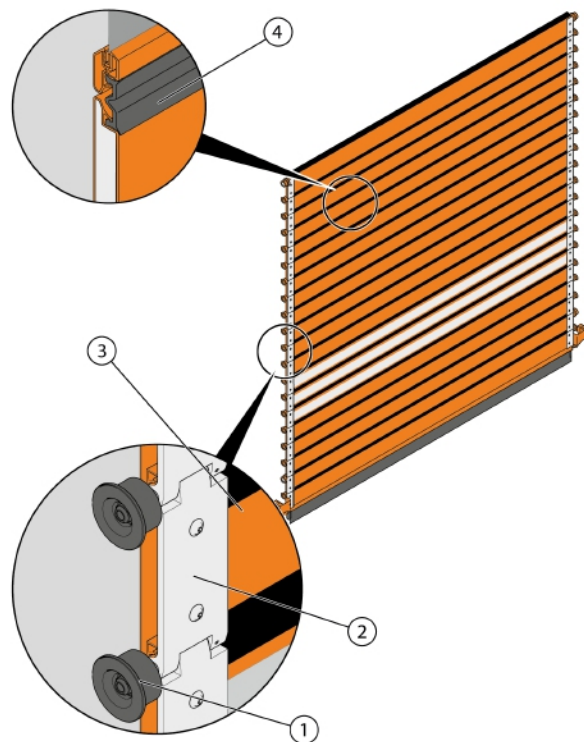

Fig. 62: Door leaf with 30 mm thick EFA-ALUX® aluminium laths and a spacing of 151 mm

Construction of the high-speed spiral door

Door leaf, laths and door leaf design > Door systems 340 R; 341 R; 342 R

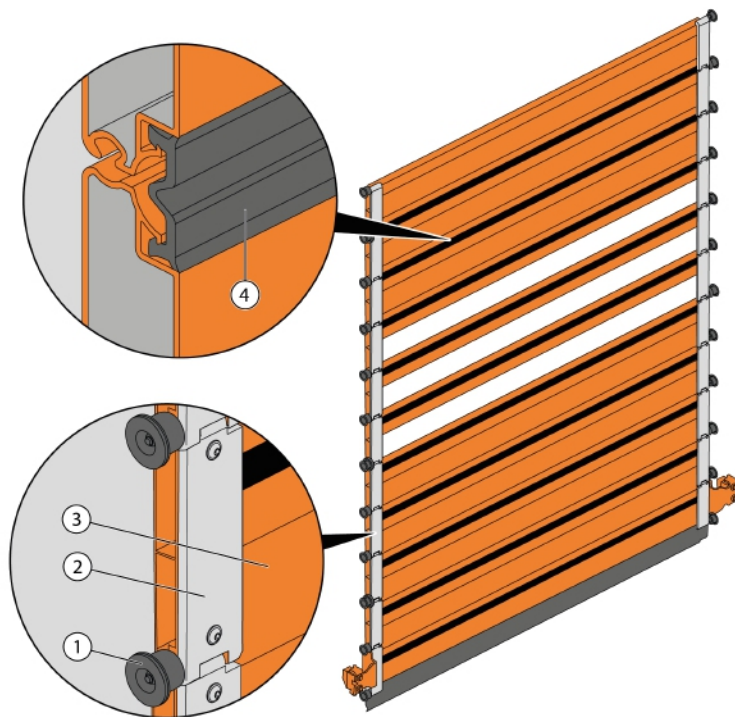

Fig. 63: Door leaf with 30 mm thick EFA-ALUX® aluminium laths and a spacing of 225 mm

Door system type	Thickness of the door leaf
340 R; 341 R; 342 R	30 mm

The door leaf is made up of laths (Fig. 62/3 and Fig. 63/3), which are held at the correct spacing by hinge chains (Fig. 62/2 and Fig. 63/2). This spacing prevents contact between the laths. They are thus free from wear. The forces for opening and closing the door system are transmitted via hinges.

Ball bearing mounted rollers (Fig. 62/1 and Fig. 63/1) keep the door firmly in the guides in the horizontal direction. The laths are connected to each other by rubber hinges (Fig. 62/4 and Fig. 63/4).

The door leaf is equipped with 30 mm thick EFA-ALUX® aluminium laths with a spacing of 151 mm or a spacing of 225 mm.

This homogeneous door leaf construction ensures extremely good running performance, high running speed and good wind stability.

Construction of the high-speed spiral door

Door leaf, laths and door leaf design > Door systems 340 R; 341 R; 342 R

Closing strip

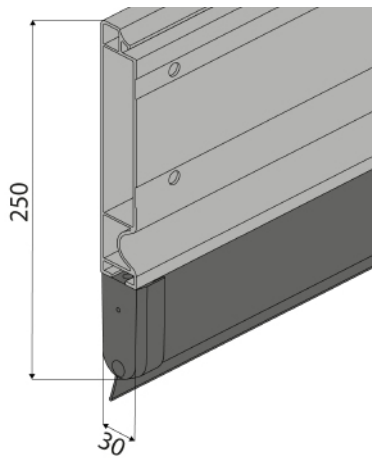

Construction	EFA-ALUX® lath with rubber closing strip (floor seal) (151 mm spacing)
	EFA-ALUX® lath with adapter profile and rubber closing strip (floor seal) (225 mm spacing)
Dimensions	30 × 250 mm (151 mm spacing)
	30 × 310 mm (225 mm spacing)
Finish	E6/EV1 (natural anodised)
Optional	Powder coating for aluminium profiles Colours in compliance with SAP

Fig. 64: Closing strip, with 151 mm spacing

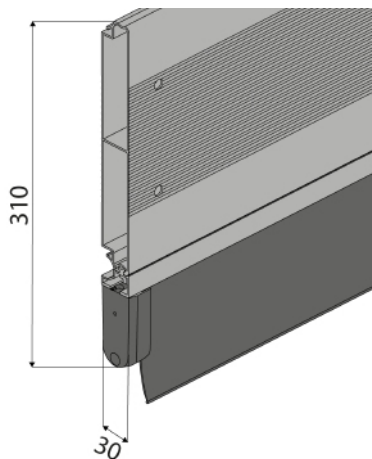

Fig. 65: Closing strip, with 225 mm spacing

Construction of the high-speed spiral door

Door leaf, laths and door leaf design > Door systems 340 R; 341 R; 342 R

EFA-ALUX® aluminium lath

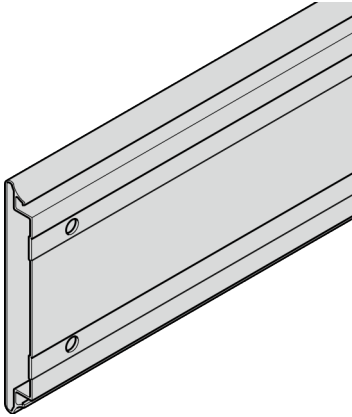

Fig. 66: EFA-ALUX® aluminium lath with 151 mm spacing

The EFA-ALUX® aluminium lath comprises a double-walled anodised aluminium profile.

Dimensions	30 × 148 mm (151 mm spacing)
	30 × 222 mm (225 mm spacing)
Finish	E6/EV1 (natural anodised)
Optional	Powder coating for aluminium profiles Colours in compliance with SAP

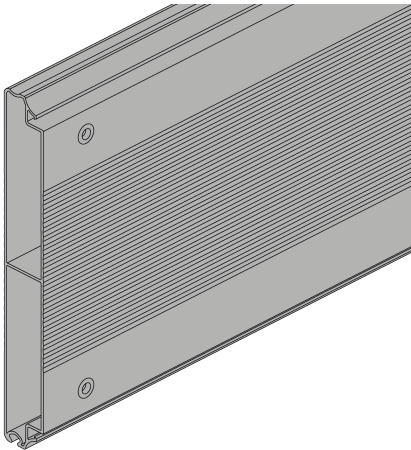

Fig. 67: EFA-ALUX® aluminium lath with 225 mm spacing

EFA-CLEAR® single-walled transparent lath (option)

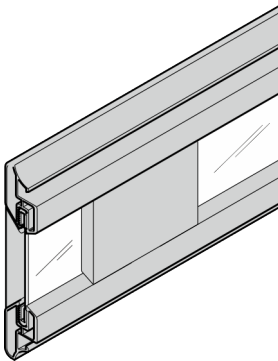

Fig. 68: EFA-CLEAR® transparent lath (single-walled)

The EFA-CLEAR® transparent lath is made up of plastic panes pressed into the aluminium profiles.

Dimensions	30 × 148 mm (151 mm spacing)
	30 × 222 mm (225 mm spacing)
Viewing area height:	■ Approx. 82 mm (151 mm spacing)
	■ Approx. 155 mm (225 mm spacing)
Finish	E6/EV1 (natural anodised)

Construction of the high-speed spiral door

Door leaf, laths and door leaf design > Corrosion protection

Glazing	SAN panes (transparent) SAN panes (non-transparent, coloured aluminium grey) Hard polycarbonate panes (scratch resistant, transparent) SAN panes with frosted glass finish (opal) and 75% translucency
Optional	Powder coating for aluminium profiles Colours in compliance with SAP

The number of EFA-CLEAR® transparent laths is not limited.

EFA-VENT® ventilation lath (optional)

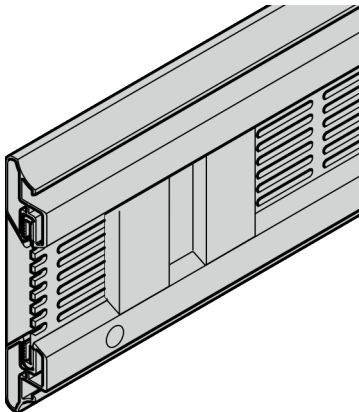

Fig. 69: EFA-VENT® ventilation lath

The EFA-VENT® ventilation laths comprise aluminium metal sheets with elongated holes (50 × 6 mm) which are pressed into aluminium profiles.

Dimensions	30 × 148 mm (151 mm spacing) 30 × 222 mm (225 mm spacing)
Finish	E6/EV1 (natural anodised)
Vent cross-section (LA) in m ²	LA = ((LB-0.105) × 0.041) × number of laths (151 mm spacing) LA = ((LB-0.105) × 0.066) × number of laths (225 mm spacing) LB = Clear width in metres
Optional	Powder coating for aluminium profiles and ventilation sheets Colours in compliance with SAP

The number of EFA-VENT® ventilation laths is not limited.

3.4.5 Corrosion protection

Regardless of equipment, the entire door system meets the requirements of corrosion protection class C3m as defined in DIN EN ISO 12944-6:2006. However, looking at the side frames and spiral cases and the door leaf individually results in different corrosion protection specifications.

Entire door system

Corrosion protection in accordance with DIN EN ISO 12944-6:2006

C3m

Construction of the high-speed spiral door

Door leaf, laths and door leaf design > Corrosion protection

Side frames and spiral case

Frame surface	Z1, steel galvanised	Z4 Powder coating	Z6, stainless steel V2A
Design	Steel, galvanised (275 g/m ² , approx. 20 µm zinc coat thickness)	Steel, galvanised (275 g/m ² , approx. 20 µm zinc coat thickness) with one-sided polyester based powder coating on surface visible from outside as per RAL according to SAP (decorative surface coating). Coat thickness approx. 50 µm +/- 10 µm Sheen level in compliance with DIN EN ISO 2813 (incidence angle 60°), 75 % ± 10 % Connecting components galvanised, not coated.	V2A stainless steel, corrosion resistant; polished grain 220, V2A connecting components.
Special features	Sheet thicknesses <ul style="list-style-type: none"> ■ ≤ 4 mm: sendzimir galvanised ■ > 4 mm: electrogalvanised 	Sheet thicknesses <ul style="list-style-type: none"> ■ ≤ 4 mm: sendzimir galvanised ■ > 4 mm: electrogalvanised 	The tension springs (bright steel, oiled), the door leaf toothed belts (galvanised tension members) and various small parts cannot be made of V2A.
Corrosion protection class in accordance with DIN EN ISO 12944-6:2006, special features: Tension springs and door leaf toothed belts	C3m	C3m	C3m
Corrosion protection class in accordance with DIN EN ISO 12944-6:2006, for general steel parts / internal parts	C3m	C3m	C3m
Corrosion protection class in accordance with DIN EN ISO 12944-6:2006, for externally visible steel parts	C3m	C3m	C5-I
Use	"Normal" industrial door	"Normal" industrial door	Industrial door in areas with high humidity and aggressive atmosphere. No washing systems

Construction of the high-speed spiral door

Door leaf, laths and door leaf design > Corrosion protection

Door leaf

Lath finish	LA1, LA2, and LA4	LAS	PUL
Design	EFA-THERM® laths	EFA-THERM® laths with additional polyurethane based wet coating of the visible surface as per RAL according to SAP (decorative surface coating). Coat thickness approx. 50 µm +/- 10 µm Sheen level in compliance with DIN EN ISO 2813 (incidence angle 60°), 30 % ± 10 % Connecting components galvanised, not coated.	EFA-ALUX®, EFA-CLEAR®, EFA-VENT® with polyester based powder coating of the visible surface as per RAL according to SAP (decorative surface coating). Coat thickness approx. 50 µm +/- 10 µm Sheen level in compliance with DIN EN ISO 2813 (incidence angle 60°), 75 % ± 10 %
Special features	-	Corrosion protection class as per DIN EN ISO 12944-6:2006 is only valid for steel components, therefore is not applicable for EFA-CLEAR® or EFA-VENT® aluminium laths.	Corrosion protection class as per DIN EN ISO 12944-6:2006 is only valid for steel components, therefore is not applicable for aluminium laths.
Door leaf corrosion protection class as per DIN EN ISO 12944-6:2006	C3m	C4m	Based on C3m
Use	“Normal” industrial door	Industrial door in areas with high humidity and aggressive atmosphere. No washing systems	-

DIN EN ISO 12944

Corrosivity category	Area of application		Note (EFAFLEX)
	Exterior	Interior	
C1, insignificant		Heated buildings with a neutral atmosphere, e.g. offices, shops, schools, hotels.	Interior doors
C2, low	Atmospheres with a low degree of pollution. Mostly rural areas.	Unheated buildings where condensation can form, e.g. warehouses, sports halls.	Unheated hall

Construction of the high-speed spiral door

Door leaf, laths and door leaf design > Corrosion protection

Corrosivity category	Area of application		Note (EFAFLEX)
	Exterior	Interior	
C3, moderate	Urban and industrial atmospheres, moderate pollution from sulphur dioxide. Coastal areas with low salinity.	Production areas with high humidity and some air pollution, e.g. food production plants, laundries, breweries, dairies.	This is only about the climate, not about any cleaning agents used!
C4, heavy	Industrial areas and coastal regions with moderate salinity.	Chemical plants, swimming pools, boathouses over seawater.	Technical release required! Restrictions on warranty and guarantee required! Increased maintenance effort!
C5-I, very heavy	Industrial areas with high humidity and an aggressive atmosphere, as well as coastal areas with heavy salinity.	Buildings or areas with almost constant condensation and heavy pollution.	

Duration of protection

l – low	low	2 to 5 years
m – medium	medium	5 to 10 years
h – high	high	over 15 years

Construction of the high-speed spiral door

Seal > Seal for 290 R; 291 R; 292 R; 320 R; 321 R; 322 R; 340 R; 341 R; 342

3.5 Seal

3.5.1 Seal for 290 R; 291 R; 292 R; 320 R; 321 R; 322 R; 340 R; 341 R; 342

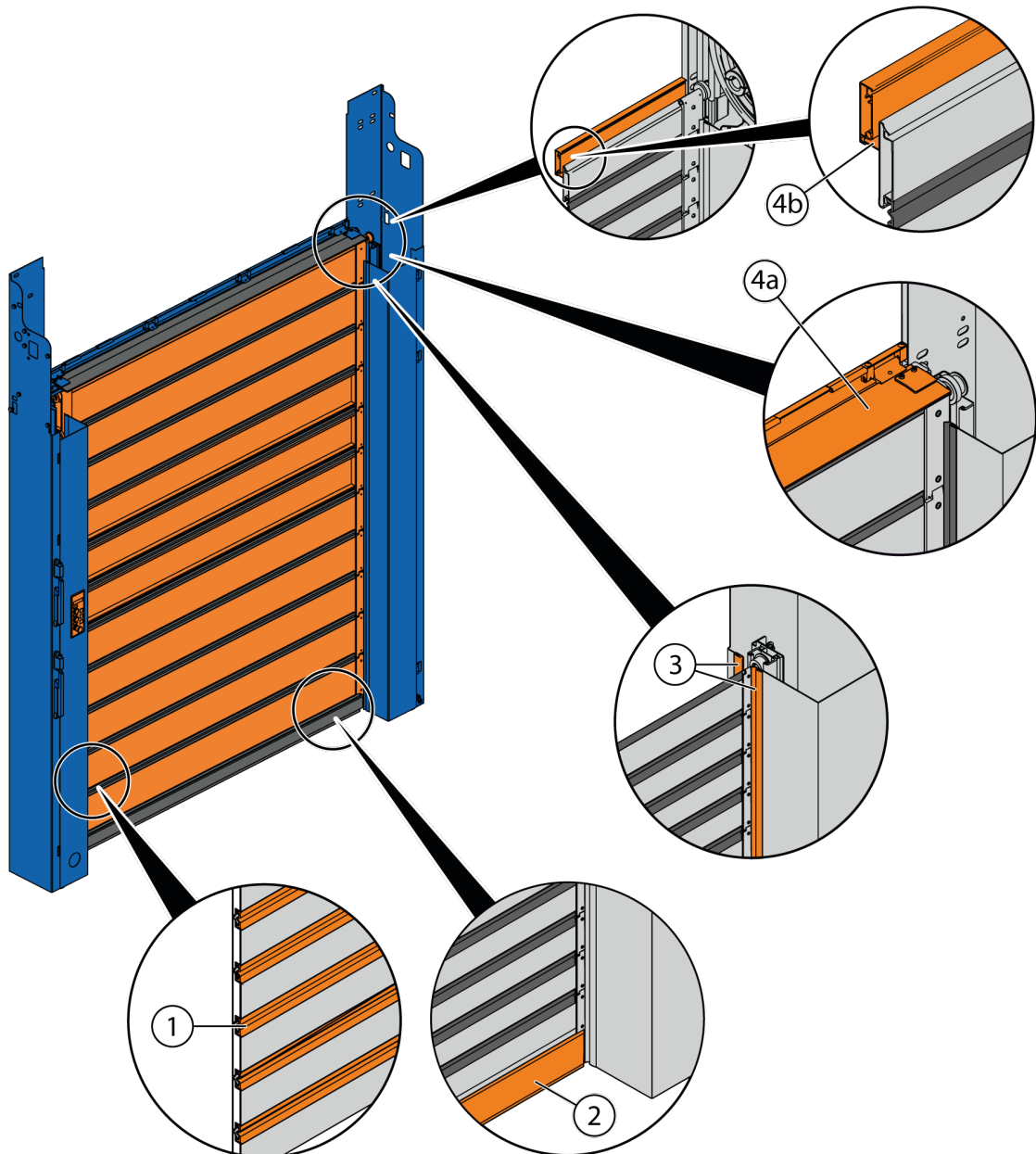

Fig. 70: Seal for 290 R; 291 R; 292 R (4a) and 320 R, 321 R; 322 R; 340 R; 341 R; 342 R (4b)

Construction of the high-speed spiral door

Seal > Seal for 290 R; 291 R; 292 R; 320 R; 321 R; 322 R; 340 R; 341 R; 342

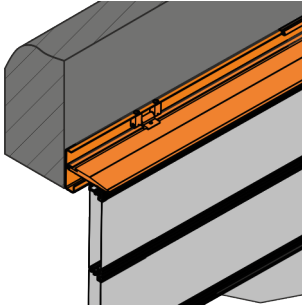

Fig. 71: Sealing profile closed

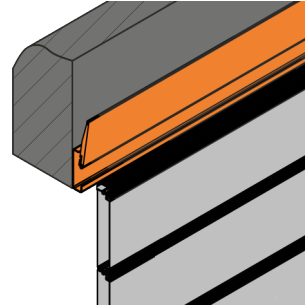

Fig. 72: Sealing profile open

The low-wear plastic door leaf seals (Fig. 70/3) provide the vertical sealing effect. The horizontal rubber profile (Fig. 70/2) protrudes as far as the side frame on the left and on the right. The laths are sealed from one another using rubber hinges and O-profiled seals (only on 290 R, 291 R and 292 R) (Fig. 70/1).

On 320 R, 321 R, 322 R, 340 R, 341 R and 342 R:

On the top of the door system, the seal is provided by a sealing profile with sealing lip, which is installed between the side frames. When the door system is closed, the top lath seals off the door leaf at the sealing profile (Fig. 70/4b).

On 290 R, 291 R and 292 R:

On door systems with a round spiral, the sealing profile is made of aluminium and seals off at the rubber profile on the top lath. The height of the sealing profile is determined by the door leaf height or the door system height and the lath spacing (Fig. 70/4a).

3.5.2 Seal on 330 R; 331 R; 332 R

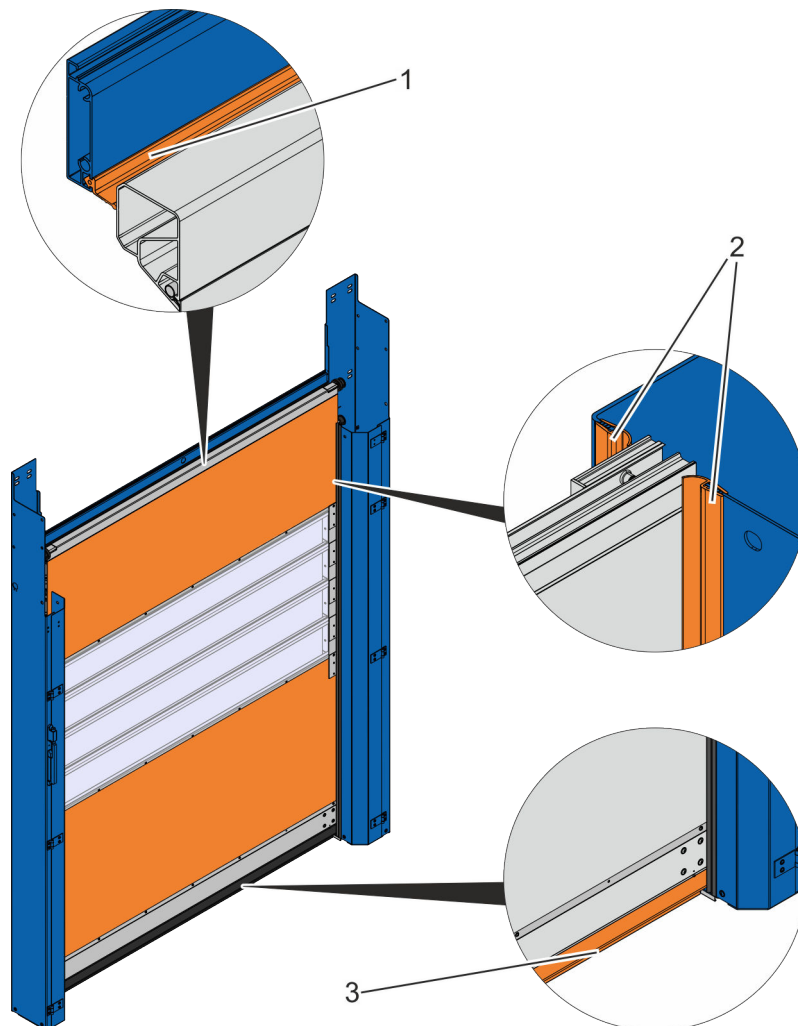

Fig. 73: Seal on 330 R; 331 R; 332 R

A sealing profile, mounted on the lintel, seals off the top of the door system. If the door system is closed, the rubber lip seals against the laths (Fig. 73/1).

Low-wear rubber lips (Fig. 73/2), which are attached in front of and behind the door leaf, provide the vertical seal. A rubber profile (Fig. 73/3) that protrudes into the side frame on the left and right is used on the closing strip for horizontal sealing to the floor.

Construction of the high-speed spiral door

Control units

3.6 Drives

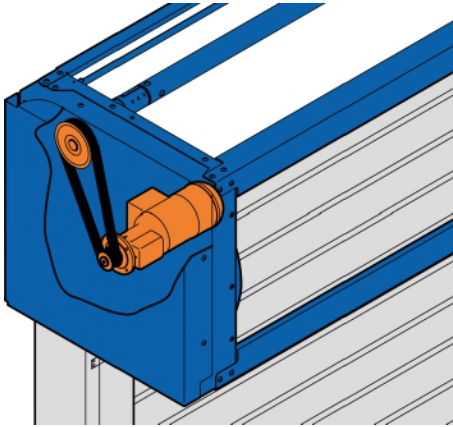

Fig. 74: Drive

All door systems	
Drive type	Integrated into the spiral to save space; transmission of force via toothed belt (Spur gear, asynchronous AC motor)
Power classes	0.55 kW – 1.5 kW
Protection type	IP54
Position detection	Door system types: Premium and ECO Absolute encoder. Thus no reference run is required.
	Door system types: Basic Incremental encoder

3.7 Control units

Door system type	EFA-TRONIC®	EFA-TRONIC® Professional	EFA-TRONIC® light	Installation position
Premium	●	○	-	● On the wall ○ Integrated
Eco	●	○	-	● On the wall ○ Integrated
Basic	○	○	●	Only possible on the wall

- Standard
- Optional
- not available

EFA-TRONIC control unit®



Fig. 75: EFA-TRONIC control unit®

Control unit	EFA-TRONIC® with frequency converter
Size (W × H × D)	210 × 400 (565)* × 200 mm (* incl. cable cover)
Housing	Polycarbonate housing
Protection type	IP65
Viewing window for display	Display of status messages and fault messages
Operating controls	Operating panel for operation and configuration of the door system Master switch
Supply voltage	L/N/PE 230 V ± 10 % or 3~L/N/PE 400 V ± 10 %
Frequency	50 – 60 Hz
Supply cable	Fuse protection 16 A to be provided by the user (K characteristic)
With residual current device (RCD) as necessary	300 mA in compliance with DIN VDE 0100-530 (sensitive to universal current)

Construction of the high-speed spiral door

Control units

EFA-TRONIC® Professional

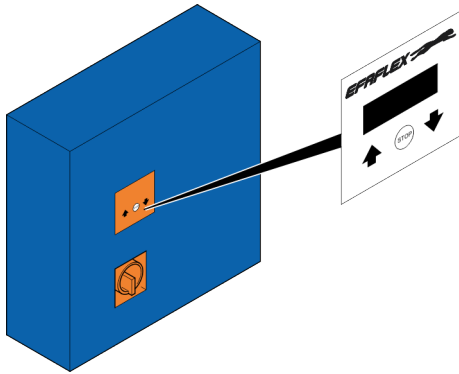

Fig. 76: EFA-TRONIC® Professional

Control unit	EFA-TRONIC® Professional with frequency converter
Size (W × H × D)	380 × 380 × 210 mm
Housing	Steel, colour RAL 7035 Optionally: <ul style="list-style-type: none"> ■ Painted RAL, colours in compliance with SAP ■ V2A
Protection type	IP54
Viewing window for display	Display of status messages and fault messages
Operating controls	Operating panel for operation and configuration of the door system Master switch
Supply voltage	L/N/PE 230 V ± 10 % or 3~L/N/PE 400 V ± 10 %
Frequency	50 – 60 Hz
Supply cable	Fuse protection of 16 A to be provided on-site (K characteristic)
With residual current device (RCD) as necessary	300 mA in compliance with DIN VDE 0100-530 (sensitive to universal current)

EFA-TRONIC® light

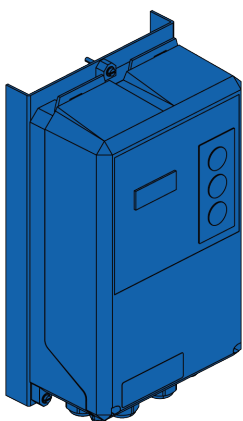

Fig. 77: EFA-TRONIC® light

Control unit	EFA-TRONIC® light with frequency converter
Size (W × H × D)	182 × 328 × 121 mm
Housing	Polycarbonate housing
Protection type	IP54
Viewing window for display	Display of status messages and fault messages
Operating control	Operating panel for operation and configuration of the door system
Supply voltage	L/N/PE 230 V ± 10 %
Frequency	50–60 Hz
Supply cable	Fuse protection of 16 A to be provided by the user (K characteristic)

Construction of the high-speed spiral door

Control units

With residual current device (RCD) as necessary	300 mA in compliance with DIN VDE 0100-530 (sensitive to universal current)
Power supply	Standard: CEE plug 16A 1P blue ("L+N+PE+6h" in compliance with IEC 60309)

EFA-HDI® operating unit

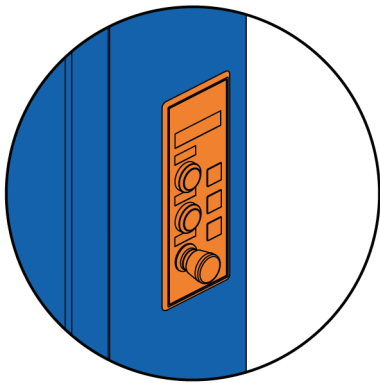

It is possible to install an additional operating unit to supplement the EFA-TRONIC®. It is equipped with a display screen and offers full access to all parameters and all basic functions.

Fig. 78: EFA-HDI® operating unit

Construction of the high-speed spiral door

Integrated control unit

3.8 Integrated control unit

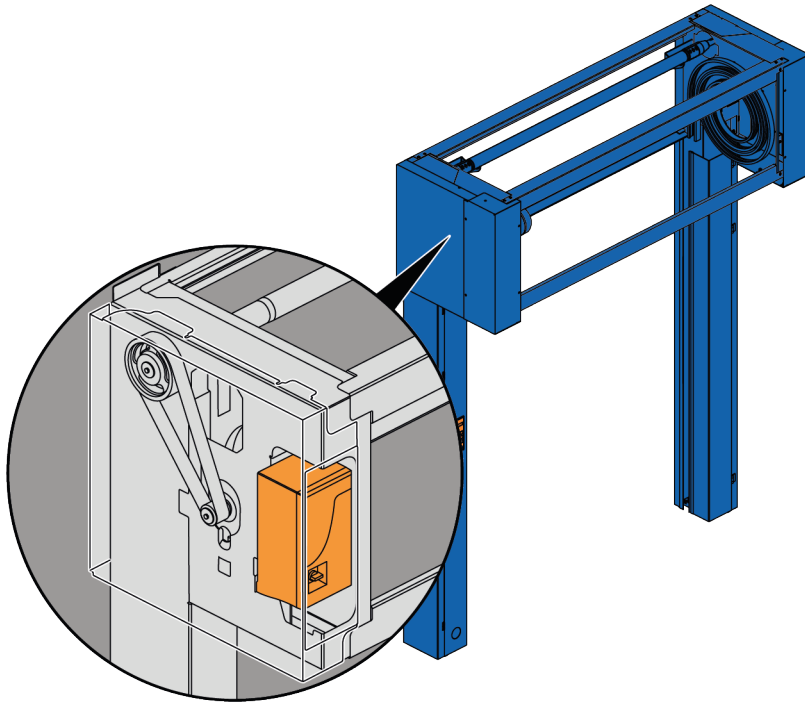

Fig. 79: Integrated control unit

As an option, the EFA-TRONIC[®] control unit can be integrated into the console (Fig. 79). With this option, the side frame covers always have a hinged design and the EFA-HDI[®] is factory-installed in the side frame cover (Fig. 80).

The control unit has a plug-in power supply. Accordingly the following preparations must be made by the user adjacent to the operator side, depending on the supply voltage:

- Blue three-pin CEE socket (IEC 60309-2) with 1/N/PE AC 230 V design, or
- Red five-pin CEE socket (IEC 60309-2) with 3/N/PE AC 400 V design

The socket should be max. 500 mm away from the side frame at a height of approx. 1,000 mm. Only one EFA-HDI[®] can be used per door system.

Construction of the high-speed spiral door

Integrated control unit

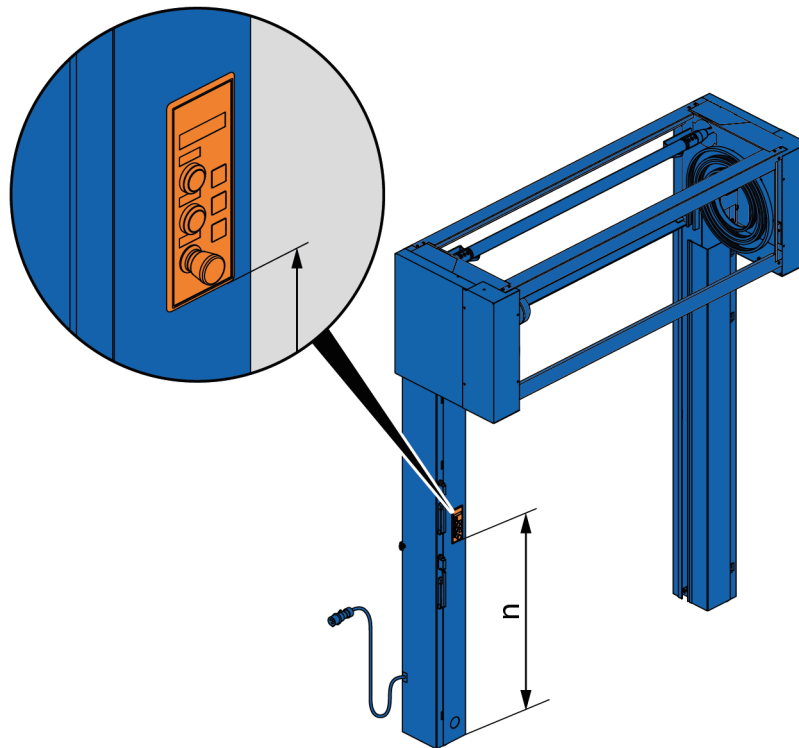

Fig. 80: EFA-HDI®

n	Dimensions
1340 mm	$1700 \text{ mm} \leq \text{LH} \leq 5100 \text{ mm}$
LH - 360 mm	$1300 \text{ mm} \leq \text{LH} \leq 1699 \text{ mm}$

LH = Clear height

4 Door safety

Available door safety

Door system type	Safety edge and light barrier	Door light grid	Door light grid and safety edge
Premium	-	●	○
Eco	○	●	○
Basic	●	○	-

- Standard
- Optional
- not available



Extension of the closing strip is an exception (↪ Chapter 3.2.6 'Flexible closing strip extension' on page 28):

- *The safety edge and the door light grid are always pre-assigned.*



Simultaneous installation of a door light grid and light barrier(s) is not possible.

The main closing edge is secured by a combination of a safety edge and light barrier(s) (C device plus D device). This achieves the minimum protection level in line with DIN EN 12453.



In addition, the owner and the manufacturer have to consult with one another on providing protection for the approach area. This will be based on the owner's risk assessment.

4.1 Safety edge and light barrier

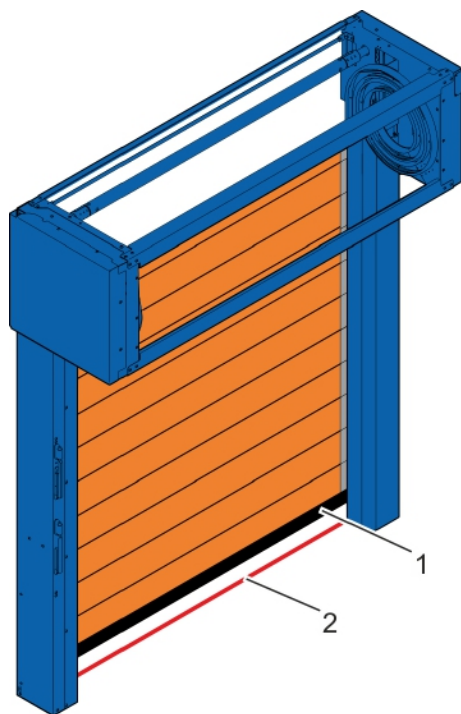

1	Safeguard for closing edge	Safety edge
2	Light barrier (optional)	Unidirectional light barriers (IP67) max. 2

If the safety edge comes into contact with a person during the closing procedure, the door leaf stops, the door system opens completely and closes automatically again once the "keep-open" time has elapsed.

The light barriers installed in the side frames at the sides are located at the door closing level. The height of the light barriers is variable.

Fig. 81: Safety edge and light barrier

4.2 Door light grid

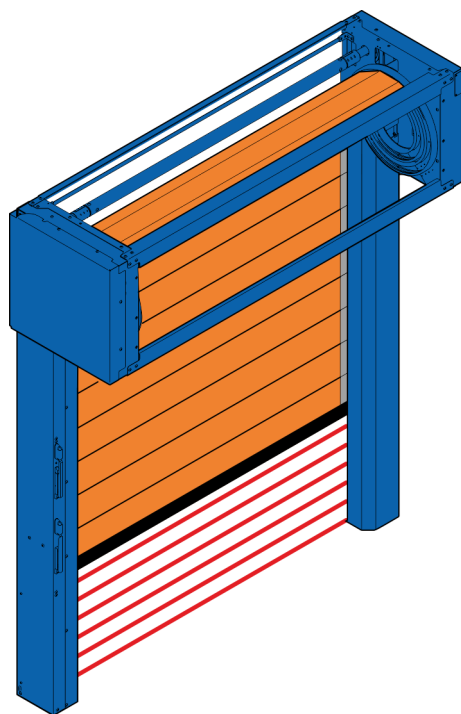

The door light grid, which is installed in the side of the side frame, monitors the closing level, up to a height of 2.5 metres. The door light grid prevents the door system from closing when a person is detected in the danger area.

On door systems, an optional safety edge can be installed in addition to the door light grid. Simultaneous installation of a door light grid and light barrier is not possible.

Fig. 82: Door light grid

4.3 EFA-SCAN®

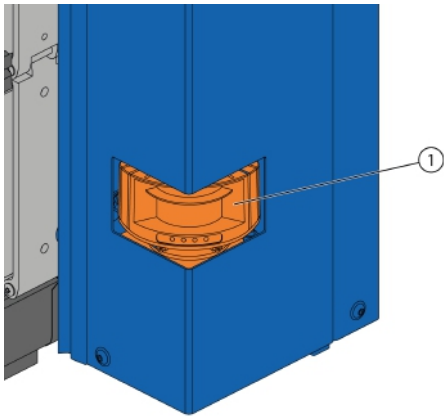

In addition to the main closing edge safeguard, the EFA-SCAN® (Fig. 83/1) can be integrated into the side frame opposite the operator side. Simultaneous selection of limit switches and EFA-SCAN® in SAP is not possible due to space restrictions.

Fig. 83: EFA-SCAN®

5 Equipment packages

Cold 1

This package provides the door system with the necessary equipment for use in the following temperature ranges:

Use	Temperature range
Area in front of door system	From -1 °C to -25 °C
Area behind door system	From -1 °C to -25 °C

Door system types	Laths
290 R, 291 R	EFA-THERM® laths EFA-CLEAR® transparent laths only with hard polycarbonate panes (scratch resistant)
320 R, 321 R	EFA-CLEAR® transparent laths only with hard polycarbonate panes (scratch resistant) or with aluminium sheet filling
330 R, 331 R	Only cover material with no viewing area
340 R, 341 R	Only laths with 225 mm spacing Optional EFA-CLEAR® transparent laths only with hard polycarbonate panes (scratch resistant)

Equipment

- Motor heating
- Basic control cabinet heating (sufficient down to -25 °C)
- Drive/gearbox with low temperature resistant oils and greases (suitable down to -25 °C)
- Door light grid (areas with high humidity are excluded in this temperature range, "Fogging" therefore only occurs to a limited extent and does not impair the door light grid).
- EFA-TRONIC® Professional control unit
- Control cabinet size 600 x 600 mm
- Door leaf toothed belt with special low temperature resistant plastic compound
- Optional: External, enhanced performance light barrier

Processes

This package provides the door system with the appropriate equipment to be operated by a master control unit, with and without special requirements under the Machinery Directive.

The equipment is only suitable for the following door system types:

- 290 R, 291 R
- 320 R, 321 R

- 330 R, 331 R
- 340 R, 341 R

Equipment

- Limit switches with functional safety requirements under Machinery Directive for evaluation in master control unit.
- Control unit in steel housing with master switch as emergency stop switch (red/yellow), alternatively in black design
- Controls exclusively inside the housing
- Housing lockable
- Predefined I/O control interface on terminal strip
 - “Door open” (potential-free)
 - “Door closed” (potential-free)
 - “Door ready” (potential-free)
 - Open and close operation using pulse control
 - Emergency stop input

Security 1

This package provides the door system with the appropriate equipment to meet the requirement for “Alarm system for loss prevention (VdS)”, including control input for blocking the pulser. See [VdS Schadenverhütung GmbH](#).

The equipment is only suitable for the following door system types:

- 290 R, 291 R
- 320 R, 321 R
- 340 R, 341 R

Equipment

- Mechanical locking mechanism
- Depending on customer requirements, the following “roll-up door contacts” can be selected in SAP:
 - LSN/VdS B
 - CT/VdS B
 - LSN/VdS C
 - CT/VdS C

CT: Conventional technology

LSN: Local Security Network

Security 2

This package provides the door system with the appropriate equipment to meet the requirement for “Alarm system for loss prevention (VdS)”, including control input for blocking the pulser. See [VdS Schadenverhütung GmbH](#).

The equipment is only suitable for the following door system types:

- 290 R, 291 R
- 340 R, 341 R

Equipment

- Automatic locking mechanism
- Resistance class WK2/RC2
- Depending on customer requirements, the following “roll-up door contacts” can be selected in SAP:
 - LSN/VdS B
 - CT/VdS B
 - LSN/VdS C
 - CT/VdS C

CT: Conventional technology

LSN: Local Security Network

Special constructions

Special constructions/special orders are design types which are not covered, either mechanically or electrically, by standard versions in the sales price lists or by a design from the technology variants table. They have to be requested specifically. Surcharges and extended delivery times are calculated for special designs in accordance with the actual expenditure.

6 Surface design drawings

The design drawings indicate which surfaces are coated and which components have a V2A design.

Powder coating (Z4) or wet varnish (LAS)

- Only externally visible surfaces are coated.
- Connecting components (e.g. screw heads) are not coated.
See ↪ Chapter 3.4.5 'Corrosion protection' on page 57.

Stainless steel design V2A (Z6)

- Some internal small parts do not have a V2A design.
See ↪ Chapter 3.4.5 'Corrosion protection' on page 57.



The following drawings are example representations of the component positions and may differ from the actual product. Not all components are illustrated.

6.1 Component coating type

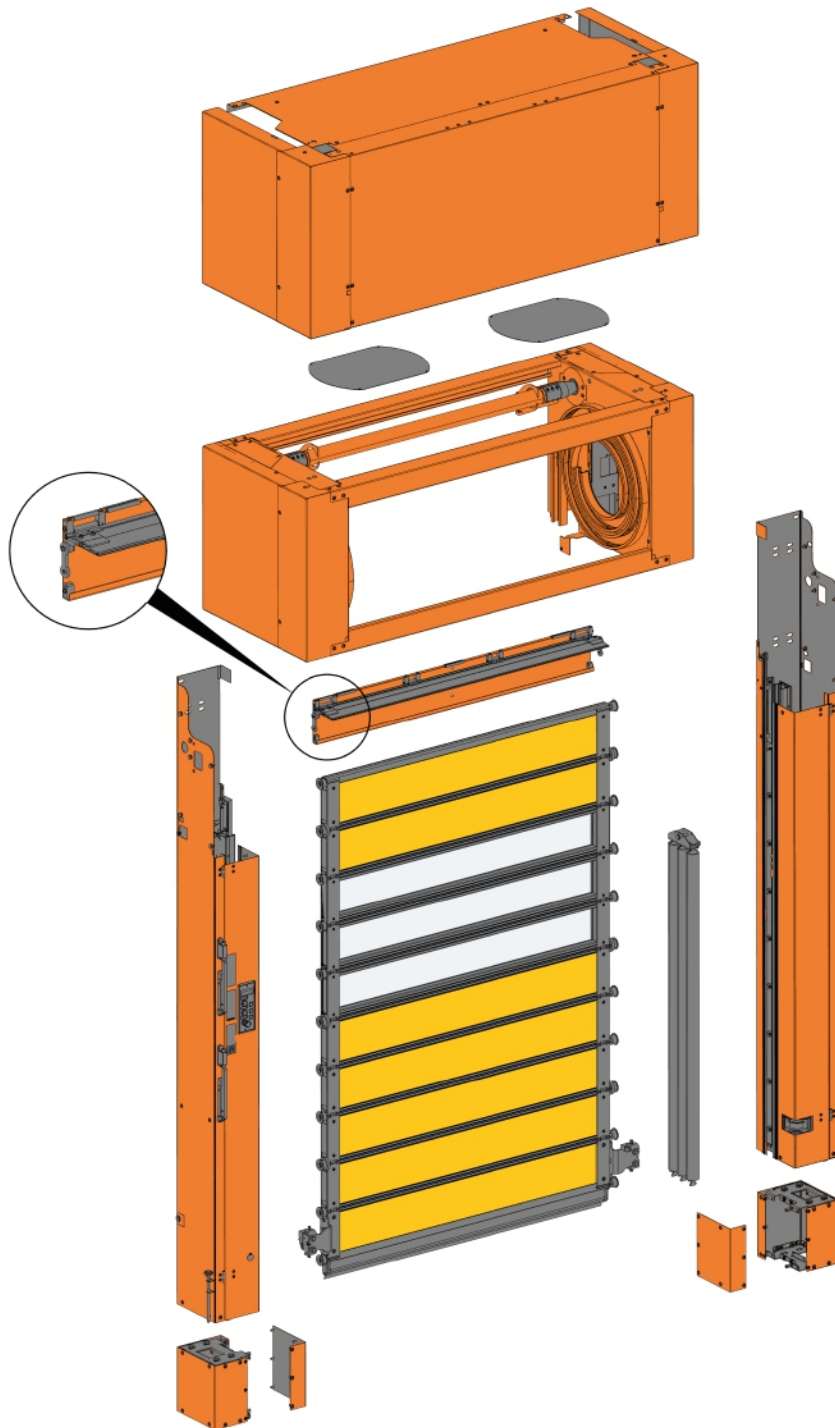

Fig. 84: All door system types

Orange Powder coating
 Grey No coating possible

Surface design drawings

Component coating type

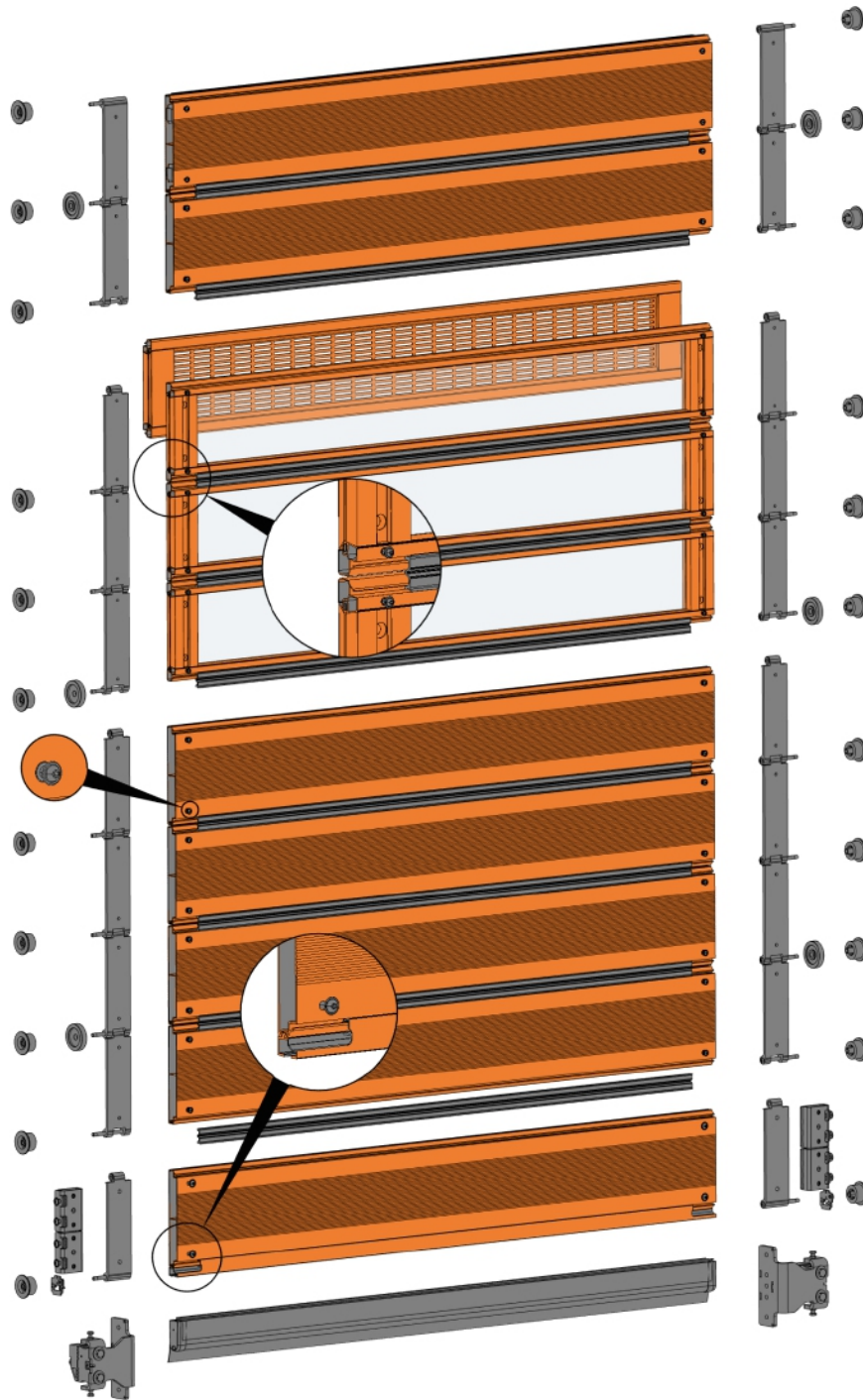

Fig. 85: EFA-SST[®]-L Classic (340 R; 341 R; 342 R)

Orange Powder coating
Grey No coating possible

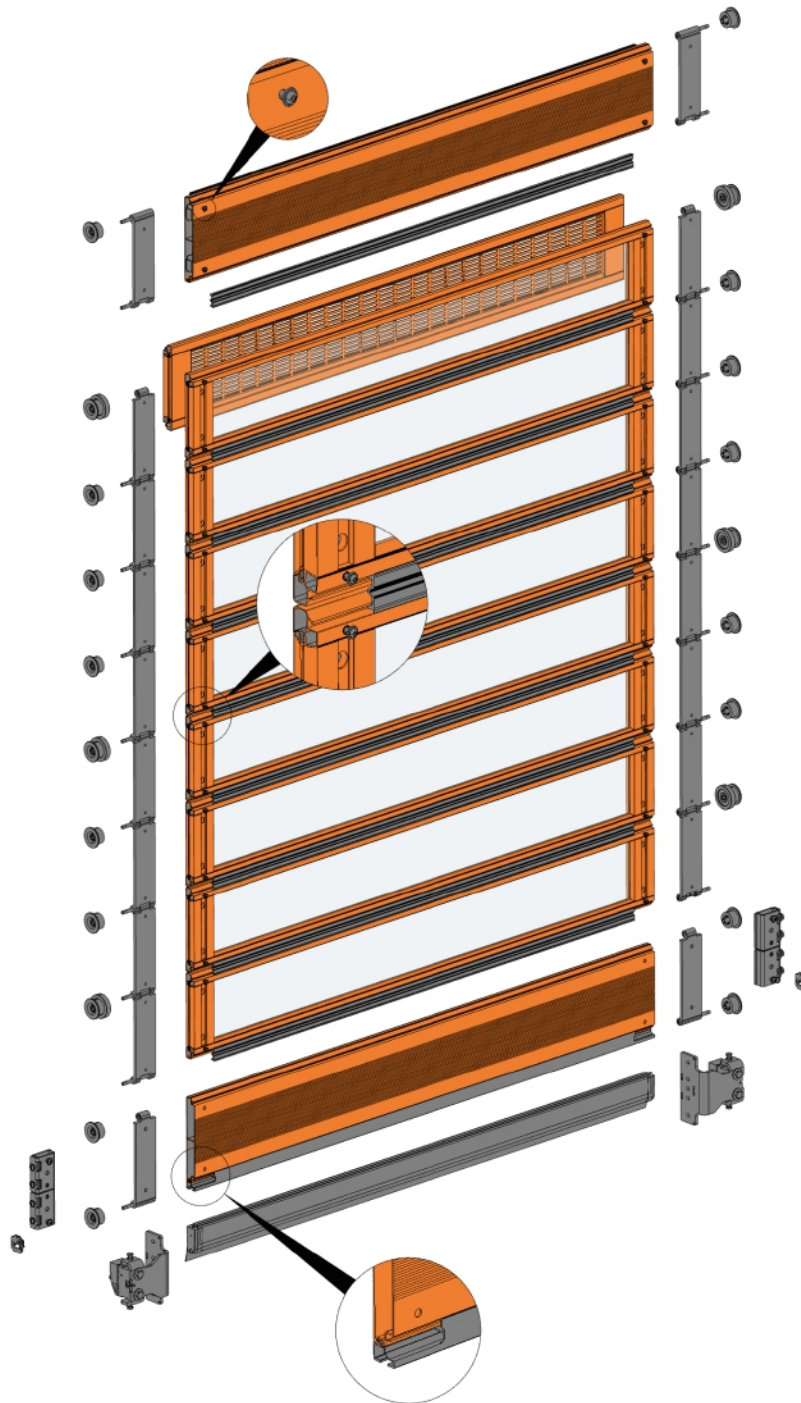

Fig. 86: EFA-STT®-L (320 R; 321 R; 322 R)

Orange Powder coating
Grey No coating possible

Surface design drawings

Component coating type

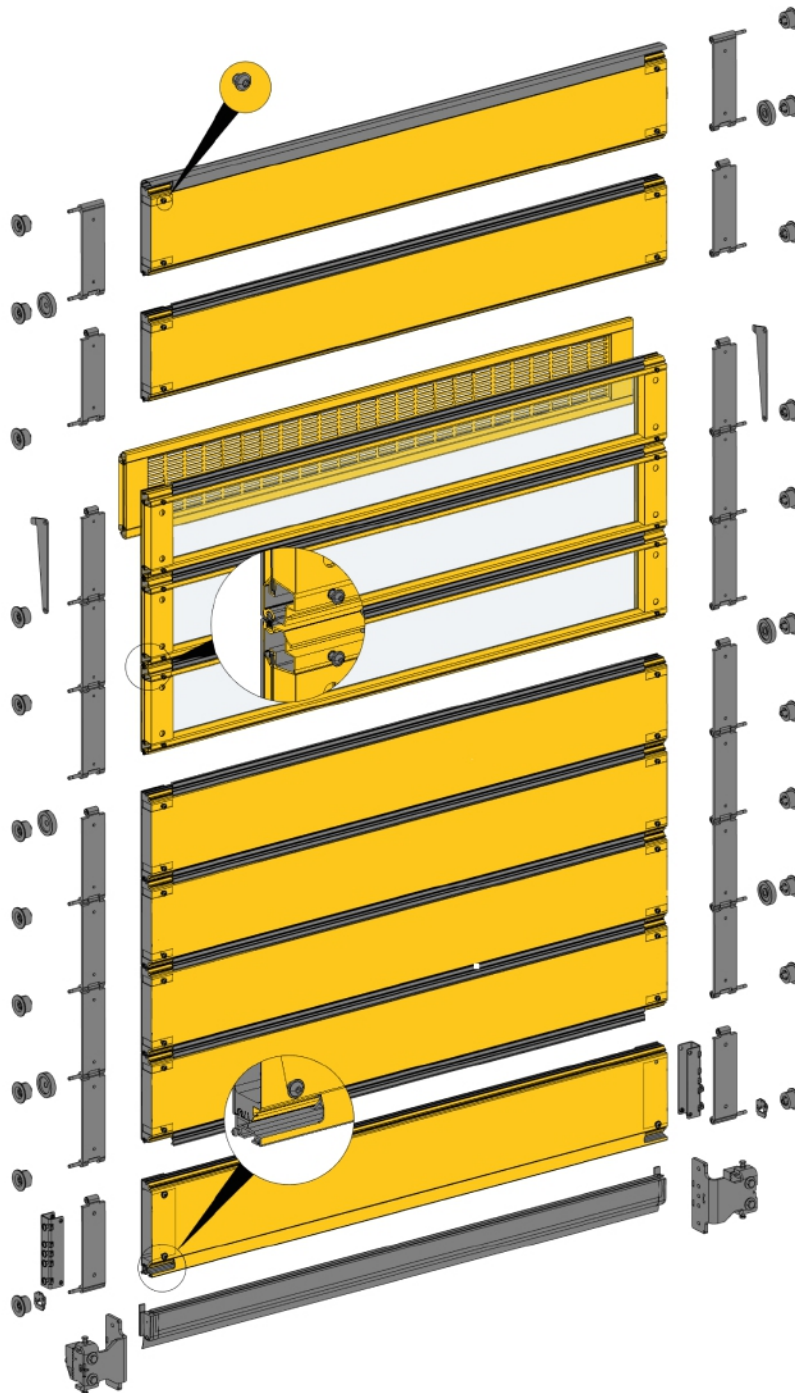

Fig. 87: EFA-SST®-L (290 R; 291 R; 292 R)

Yellow Wet coating
Grey No coating possible



The door leaf for door system types 330 R, 331 R and 332 R cannot be coated.

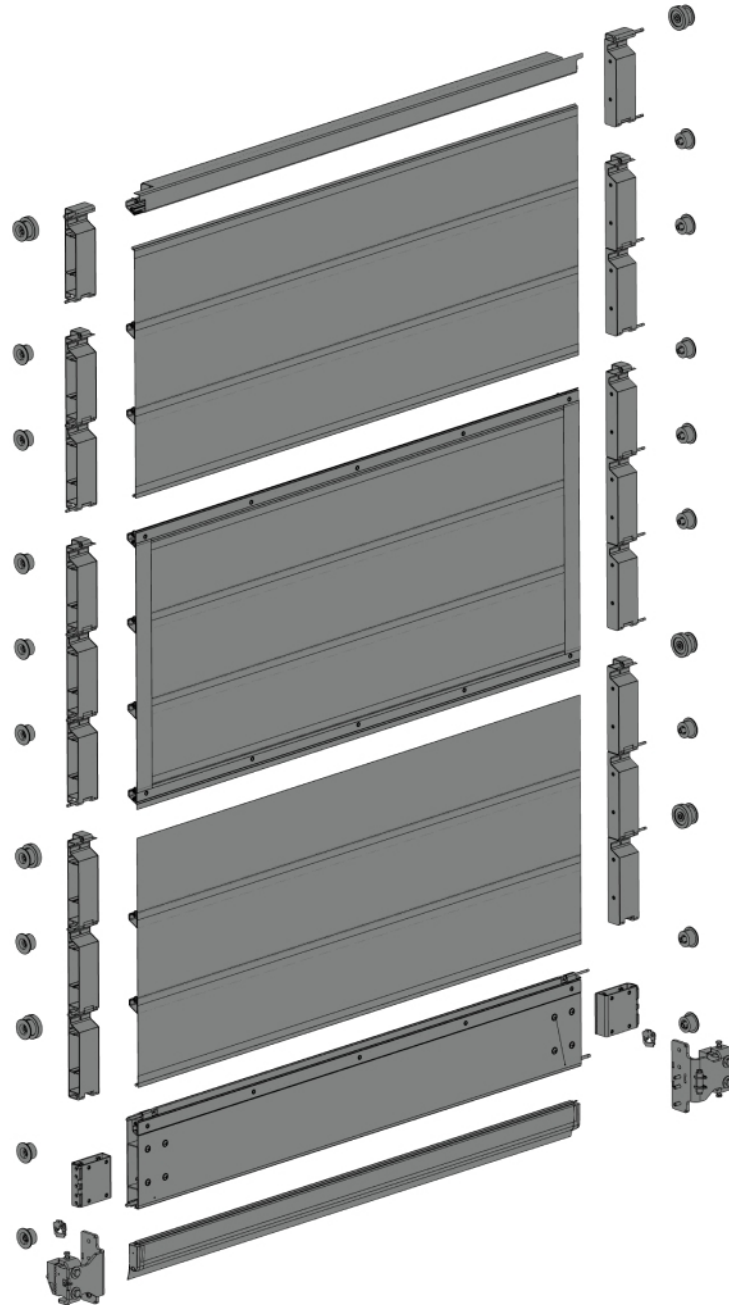

Fig. 88: EFA-STR[®]-L (330 R; 331 R; 332 R)

Grey No coating possible

Surface design drawings

Stainless steel design components (V2A)

6.2 Stainless steel design components (V2A)

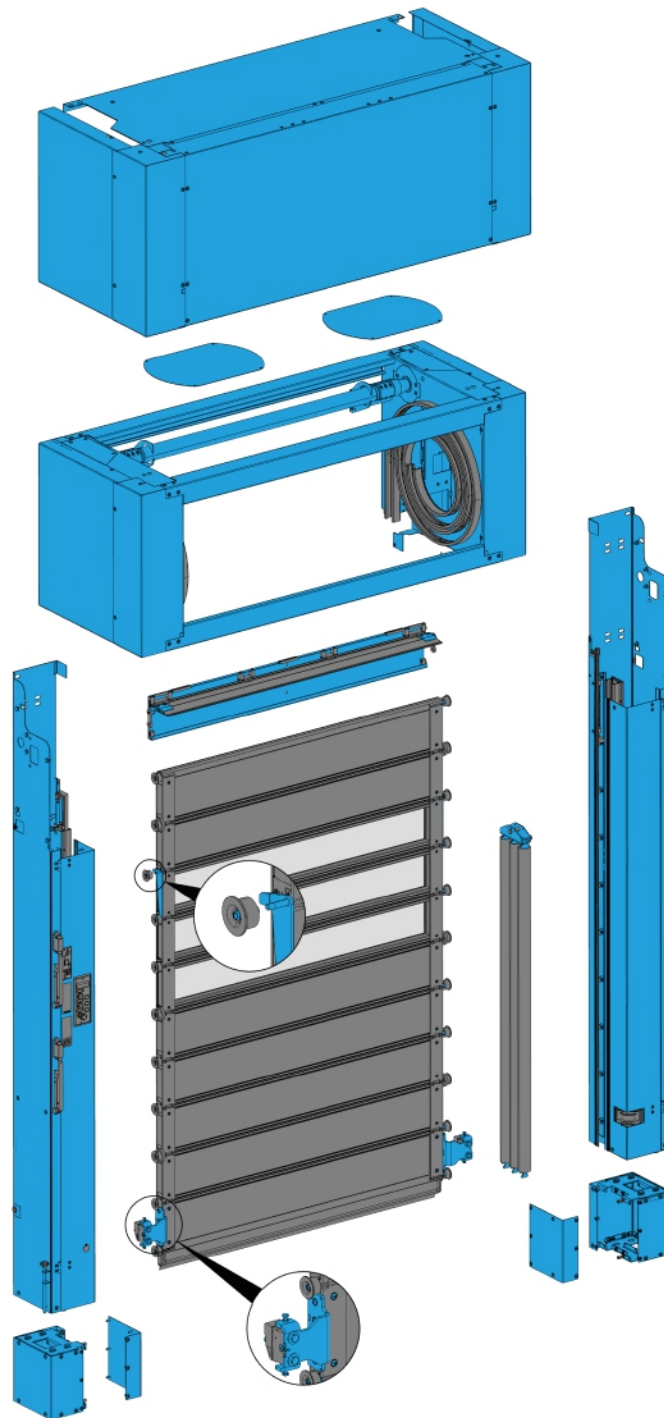

Fig. 89: Complete door system
Light blue V2A

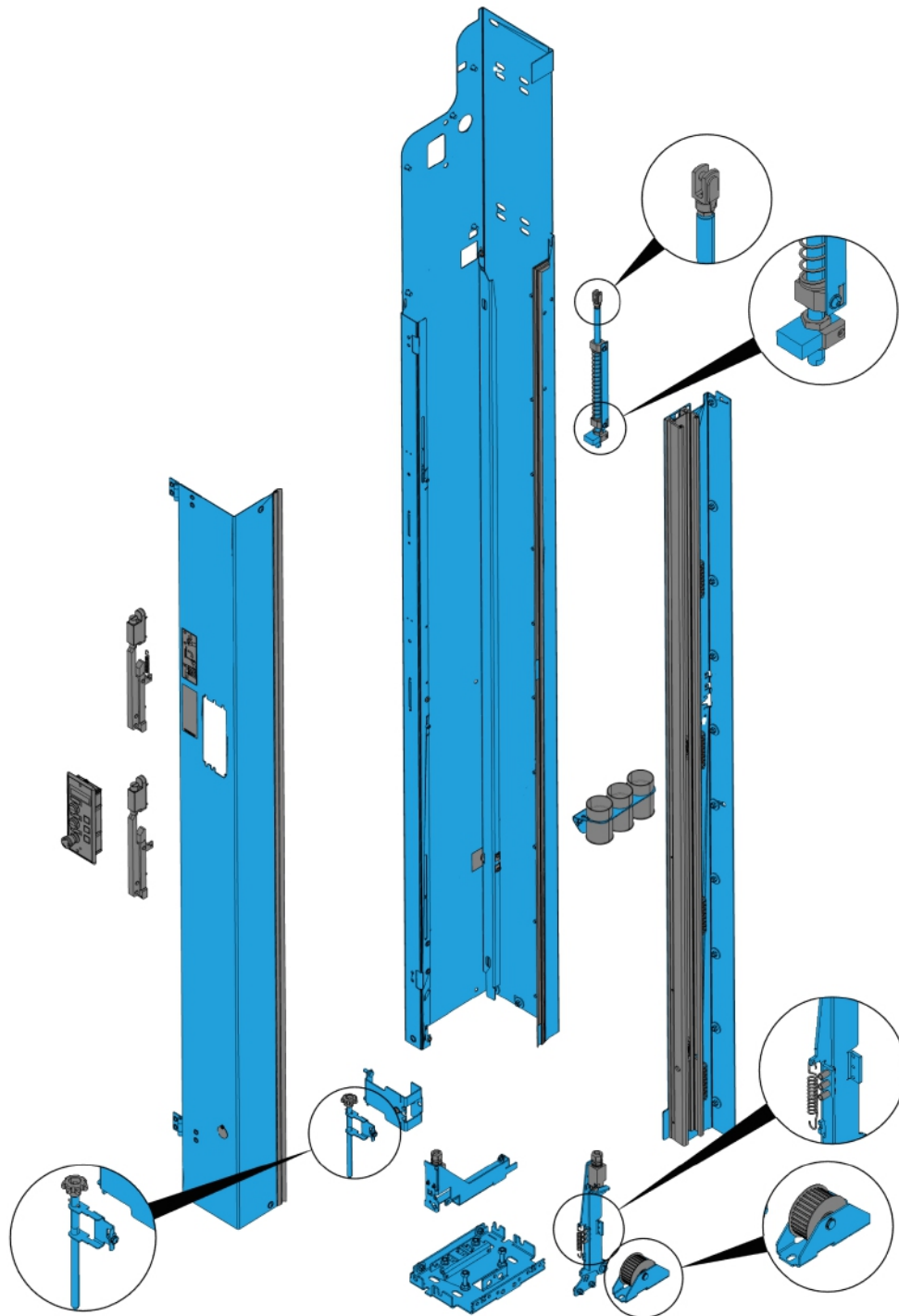

Fig. 90: Left side frame
Light blue V2A

Surface design drawings

Stainless steel design components (V2A)

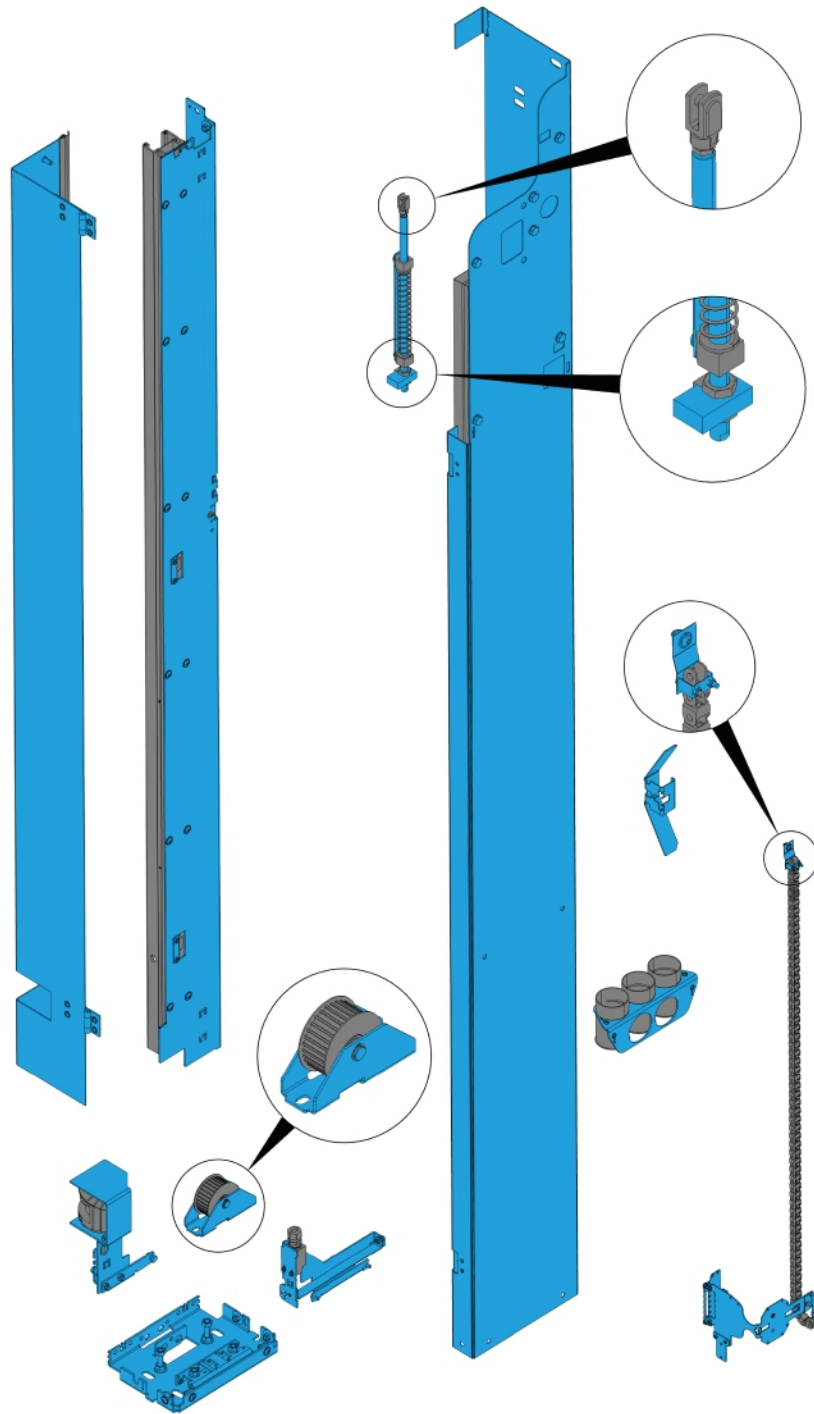

Fig. 91: Right side frame

Light blue V2A

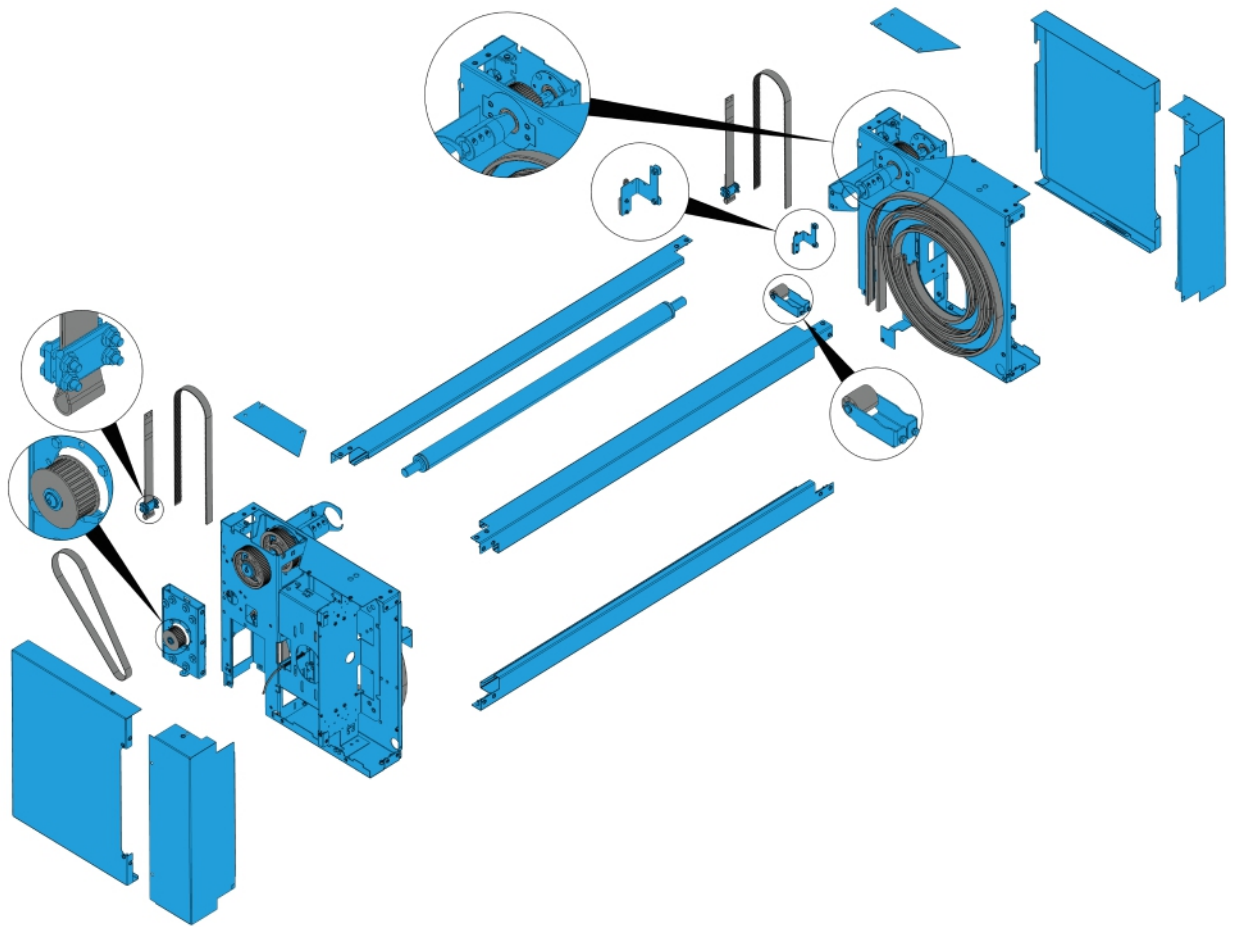

Fig. 92: Spiral case

Light blue V2A

Surface design drawings

Stainless steel design components (V2A)

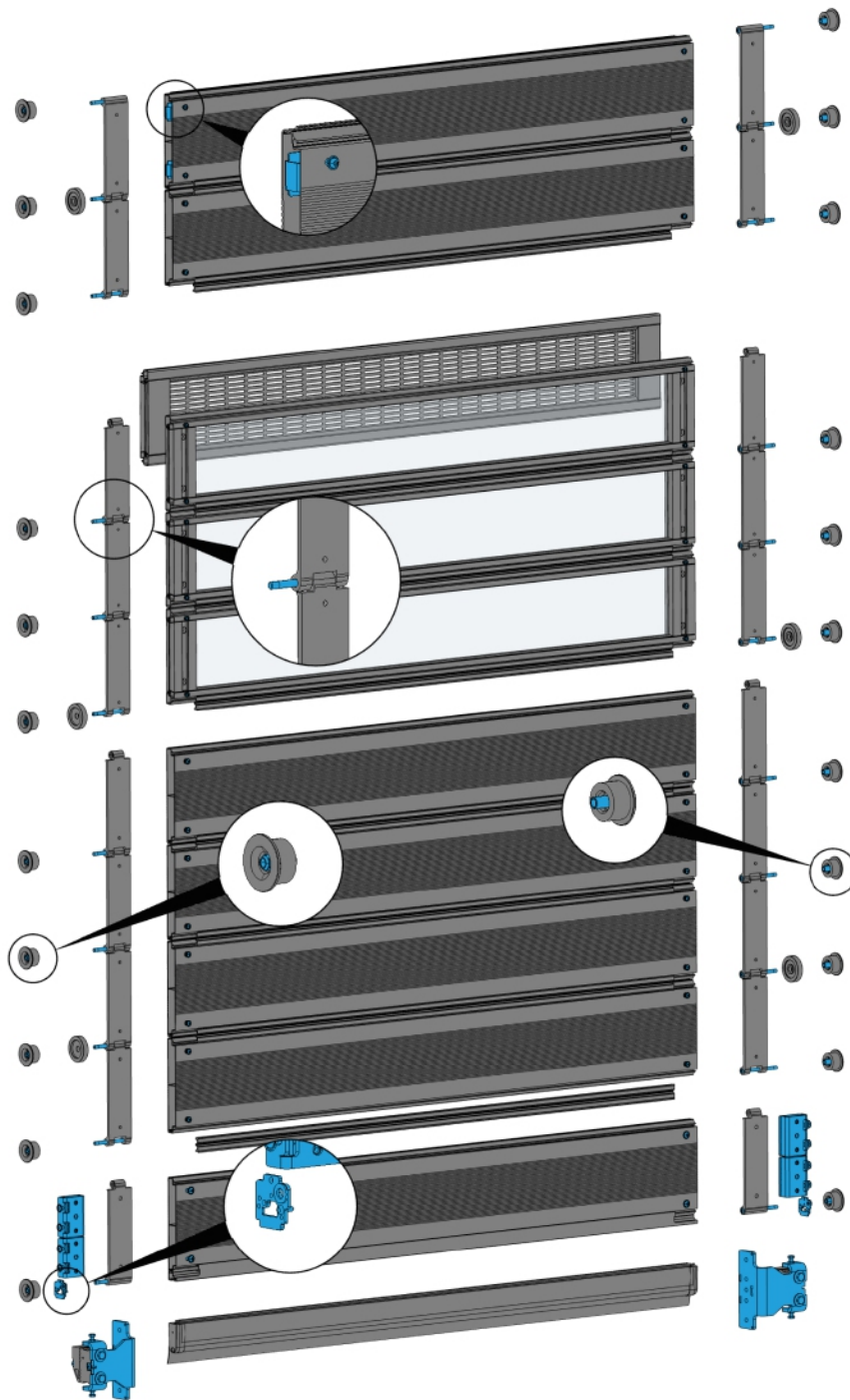

Fig. 93: Door leaf

Light blue V2A

7 Packaging units

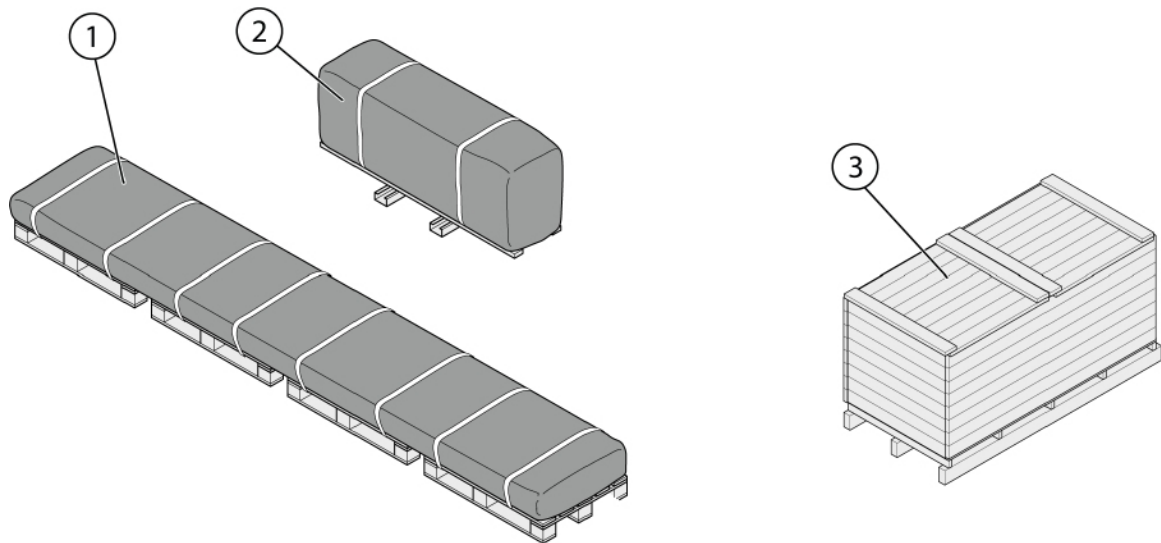

Fig. 94: Scope of delivery (left, standard transport unit), wooden crate (right, optional, for sea and fit-for-purpose* transport)



**Fit-for-purpose packaging is packaging that ensures that the packaged goods reach the recipient without damage, taking into account the shipping loads, shipping route, shipping duration and transportation load profile.*

Transport unit (example)

Transport unit 1: Side frames with accessories

Transport unit 2: Spiral case with door leaf, drive

Transport unit 3: Wooden crate (optional)

Number of transport units

The number of standard transport units depends on the selected number of door systems.

Wooden crate (optional)

The number of wooden crates depends on the configuration of the door system types and the number of door systems.

The wood for the wooden crates complies with the IPPC standard. The wooden crate is covered with film to protect the door system.

Packaging units

Packages attached to pallets can be transported by forklift under the following conditions:

- The forklift must have the appropriate capacity for the weight of the packages.
- The package must be securely fastened to the pallet.
- The forklift driver must be authorised to drive industrial trucks with a driver's seat or driver's station in accordance with the local regulations.



EFAFLEX Tor- und Sicherheitssysteme

GmbH & Co. KG

Fliederstraße 14

84079 Bruckberg

GERMANY

Telephone: +49 8765 82-0

Fax: +49 8765 82-200

Email: info@efaflex.com

Internet: www.efaflex.com