



Technical product description
High-speed roll-up door
for clean rooms



For internal use only

This technical product description applies to
the following door system types:

EFA-SRT® CR Premium

EFA-SRT® CR Efficient

EFA-SRT® CR C

EFAFLEX Tor- und Sicherheitssysteme GmbH & Co. KG

Fliederstrasse 14

84079 Bruckberg

GERMANY

Telephone: +49 8765 82-0

Fax: +49 8765 82-200

Email: info@efaflex.com

Internet: www.efaflex.com

Translation of the original

Version 09-EN

14.08.2025

© EFAFLEX Tor- und Sicherheitssysteme GmbH & Co. KG

Door system designations

Official designation of the door system	Designation of the door system in this product description	Door system type	Quotation drawing (AZ) number
EFA-SRT® CR Premium	254	Roll-up door	254xx
EFA-SRT® CR Efficient	678	Roll-up door	678xx
EFA-SRT® CR C	679	Roll-up door	679xx

Table of contents

1	Short description	5
2	Technical properties	8
	2.1 Use.....	8
	2.2 Dimensions.....	9
	2.3 Speeds.....	10
	2.4 Performance properties.....	10
	2.5 Fire performance.....	10
	2.6 Safety standards.....	11
	2.7 Use.....	11
3	Construction of the high-speed roll-up door for clean rooms	12
	3.1 Corrosion protection.....	16
	3.2 Winding shaft unit.....	18
	3.3 Cover.....	19
	3.4 Counterbalance.....	20
	3.5 Emergency operation versions.....	21
	3.5.1 Pull-button / illuminated push-button (254).....	21
	3.5.2 Manual emergency operation (678).....	22
	3.5.3 Manual release lever (679).....	22
	3.5.4 Emergency stop operating control (254).....	23
	3.5.5 Master switch.....	23
	3.6 Door leaf guide and side frames.....	24
	3.6.1 Door system type 254.....	24
	3.6.2 Door system type 678.....	25
	3.6.3 Door system type 679.....	25
	3.7 Door leaf.....	26
	3.7.1 Door leaf versions.....	27
4	Seal	31
5	Drive and control unit	33
6	Optional assembly groups	36
	6.1 Limit switch (254 only).....	36
	6.2 LED display/traffic lights (254 only).....	38
	6.3 Selector switch.....	39
	6.4 Key switch.....	39
	6.5 Contactless switch.....	39
	6.6 Infrared presence detector (254 only).....	40
7	Door safety	41
	7.1 Safety edge and light barrier.....	41
	7.2 Door light grid.....	42
8	Packaging units	43

1 Short description

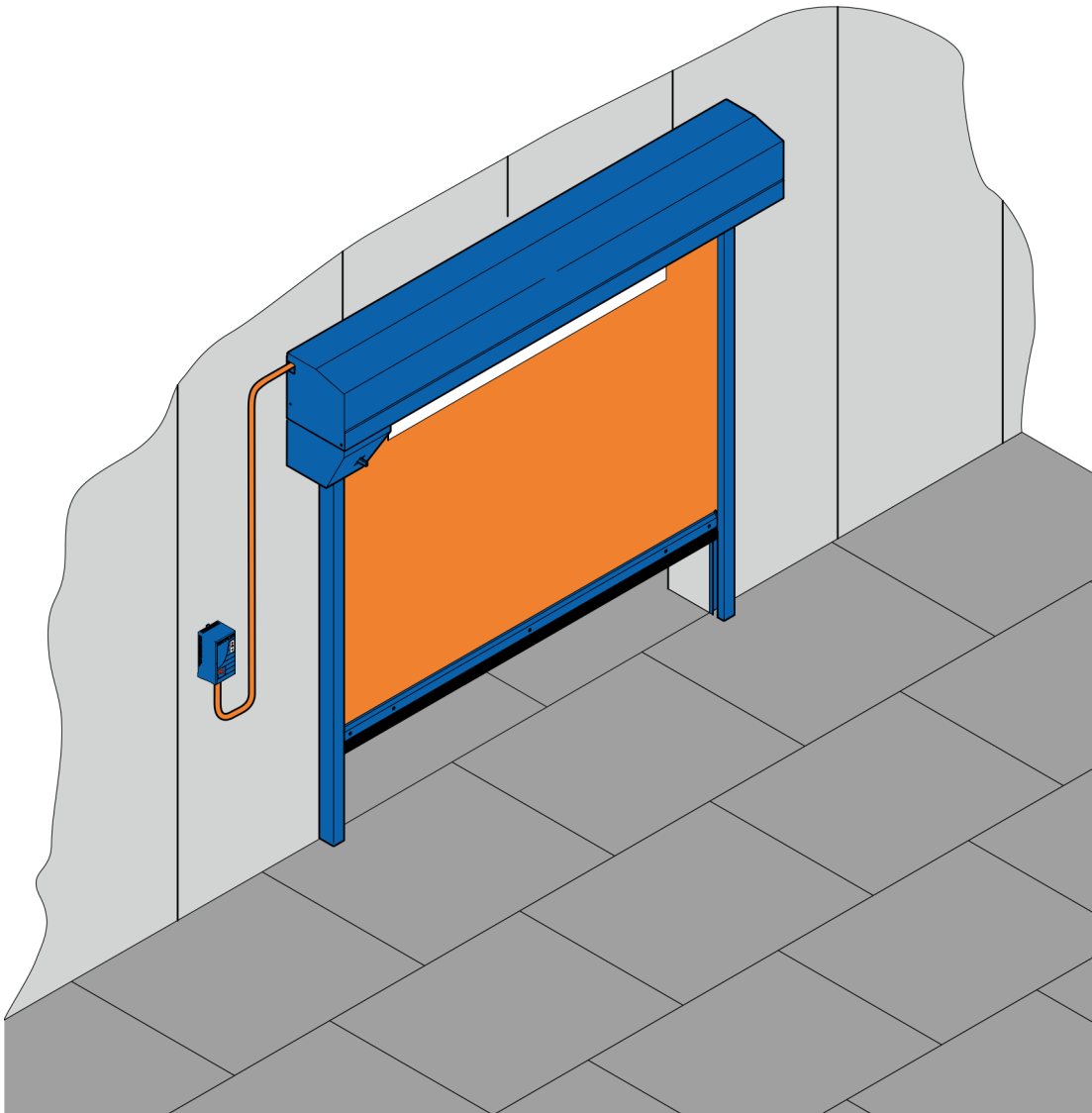

Fig. 1: High-speed roll-up door for clean rooms

The high-speed roll-up doors have been specifically engineered for application in rooms in which production takes place under clean room conditions. Different design variants have been developed to meet different requirements.

The door systems are certified and suitable for use in clean rooms. Unwanted air exchange is prevented by fast opening and closing and by minimisation of air gaps.

EFA-SRT® CR Premium

The door system type 254 is adapted to the high demands of the clean room. It complies with ISO Class 5 as per ISO 14644-1 and VDI 2083 sheet 9.1. The control unit is integrated into the side frame, which means that no further space is required in the area in front of the door system for installing an additional control cabinet. Furthermore, this space-saving version also features a drive, optional pulse generators and signalling devices that are integrated into the side frame. The side frames also have a smooth surface. An emergency opening can be performed quickly and easily thanks to the spring force of the weight counterbalance.

GMP compliance certification

In addition, the EFA-SRT® CR Premium has been specially tested and certified in accordance with the GMP (Good Manufacturing Practice) guidelines.

The GMP compliance certificate is issued on the basis of an evaluation of the following checkpoints:

- Product design
- Design quality
- Operating functionality
- Cleanability
- Technical documentation

This type of door system is therefore ideally suited to use at GMP manufacturing sites. GMP compliance certification confirms the acceptability and clean room suitability of the EFA-SRT® CR Premium for pharmaceutical applications.

GMP compliance certification complements but does not replace the operator's obligation to meet qualification and validation requirements, including an official inspection to obtain manufacturing authorization.

The GMP compliance certification is intended to reassure the operator that the purchased door system will meet GMP acceptability standards.

EFA-SRT® CR Efficient

The Efficient version of the clean room door system is characterised by a very narrow side frame design. For this purpose, the control unit can be set up in a modular solution in the vicinity of the door system. This high-speed door is thus ideally suited to conveyor systems between factory sections and storage rooms, or for use in material feeding. The requirements for ISO Class 6 as per ISO 14644-1 and VDI 2083 sheet 9.1 are also met with this high-grade version of a clean room application.

EFA-SRT® CR C

We have catered for the individual requirements of the clean room area with the EFA-SRT® CR C door system. Alongside its perfect suitability for the clean room in the cosmetics sector, the door system is also characterised by a high opening and closing speed and a wide range of installation options because it can be installed at a width and height of up to 3500 mm each.

If configured accordingly, the control unit is fitted behind the cover on the winding shaft. All displays and operating controls are then situated on the side frame. The standard version of the door construction is a stainless steel (V2A) design.

Depending on the equipment options, this version of the clean room door complies with ISO Classes 6 or 7 as set out in ISO 14644-1 and VDI 2083 sheet 9.1.

Technical properties

Use

2 Technical properties

2.1 Use

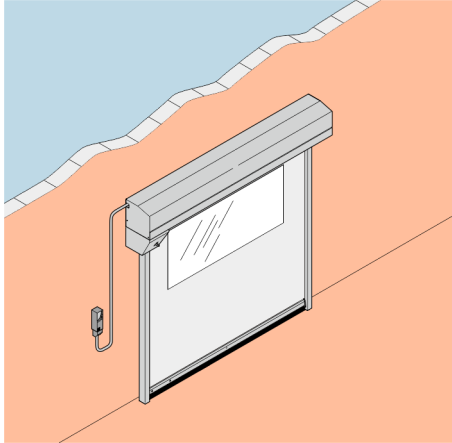

Fig. 2: Use of positive pressure

	Low pressure
	High pressure

Use

- Interior door

Area of application:

- Sealing door for rooms with air pressure differences

Temperature range for use:

- +5 °C to +30 °C

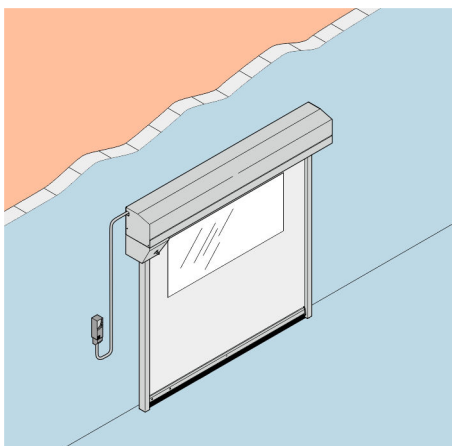

Fig. 3: Use of negative pressure

Pressure differences

Door system type	with max. door system size	with dimensions of max. 1400 mm x 2000 mm
254	max. 30 Pa	max. 50 Pa
678	max. 30 Pa	max. 30 Pa
679	max. 30 Pa	max. 30 Pa



The pressure difference can be increased once to 50 Pa to carry out a blower door test.

2.2 Dimensions

Dimensions of door system 254

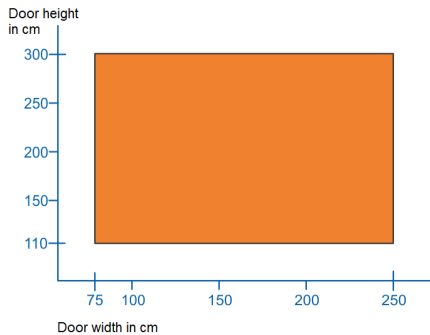

Fig. 4: Diagram of possible door system heights and widths (254)

Door system heights and widths (inner clear height)

Door system type	Widths	Heights
254	750 – 2500 mm	1100 – 3000 mm

Dimensions of door system 678

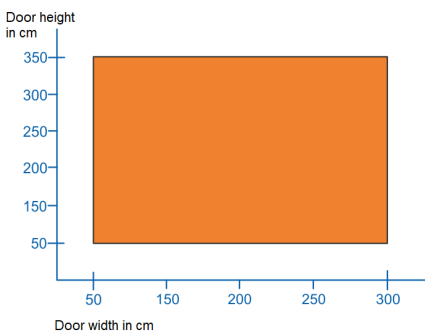

Fig. 5: Diagram of possible door system heights and widths (678)

Door system heights and widths (inner clear height)

Door system type	Widths	Heights
678	500 – 3000 mm	500 – 3500 mm

Dimensions of door system 679

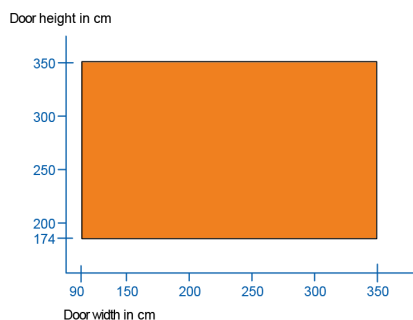

Fig. 6: Diagram of possible door system heights and widths (679)

Door system heights and widths (inner clear height)

Door system type	Widths	Heights
679	900 – 3500 mm	1740 – 3500 mm

Technical properties

Fire performance

2.3 Speeds

Door system type	Average speed	
	Opening speed	Closing speed
254	1.0 m/s	0.5 m/s
678	0.8 m/s	0.5 m/s
679	2.0 m/s	0.75 m/s

The speed depends on the door system height

2.4 Performance properties

Door system type	Air loss with positive pressure	Air loss with negative pressure	Certified for application in clean room classes in accordance with ISO 14644-1 and VDI 2083 sheet 9.1	Airborne sound insulation as per EN ISO 717-1 ²
254	< 12 m ³ /m ² h (Class 2)	< 20 m ³ /m ² h (Class 1)	ISO Class 5	Rw = 11 dB ¹
678	< 12 m ³ /m ² h (Class 2)	< 50 m ³ /m ² h (Class 0)	ISO Class 6	Rw = 11 dB ¹
679	< 20 m ³ /m ² h (Class 1)	< 50 m ³ /m ² h (Class 0)	ISO Class 6 ³ ISO Class 7 ³	Rw = 11 dB ¹

¹ with 2 mm Transilon curtain

² not tested

³ depending on configuration

2.5 Fire performance

Fire performance as per DIN 4102

Indication	Value
Material class	B2 normally inflammable

2.6 Safety standards

Applicable regulations, safety standards and directives

The following regulations, standards and directives were taken into account in planning, engineering and production:

Regulations

EUV 305/2011	REGULATION (EU) NO. 305/2011 OF THE EUROPEAN PARLIAMENT AND THE COUNCIL OF 9 March 2011 laying down harmonised conditions for the marketing of construction products and repealing Council Directive 89/106/EEC
--------------	---

Directives

2006/42/EC	DIRECTIVE 2006/42/EC OF THE EUROPEAN PARLIAMENT AND COUNCIL of 17 May 2006 on machinery, and amending Directive 95/16/EC
2014/30/EU	DIRECTIVE 2014/30/EU OF THE EUROPEAN PARLIAMENT AND COUNCIL of 26 February 2014 on harmonisation of the laws of the member states relating to electromagnetic compatibility
2014/53/EU	DIRECTIVE 2014/53/EU OF THE EUROPEAN PARLIAMENT AND OF THE COUNCIL of 16 April 2014 on the harmonisation of the laws of the Member States relating to the making available on the market of radio equipment and repealing Directive 1999/5/EC

Standards

DIN EN 13241	Doors – Product standard, performance characteristics
DIN EN ISO 13849-1	Safety of machinery – Safety-related parts of control systems – Part 1 General principles for design
DIN EN ISO 13849-2	Safety of machinery – Safety-related parts of control systems – Part 2 Validation
DIN EN ISO 12100	Safety of machinery – General principles for design – Risk assessment and risk reduction

2.7 Use

Door system type	Recommended frequency of use per year (up to)	Expected useful life ¹
254	200,000	20 years
678	100,000	
679	200,000	

¹ Includes 10 years German Product Liability Act

3 Construction of the high-speed roll-up door for clean rooms

Door system type 254

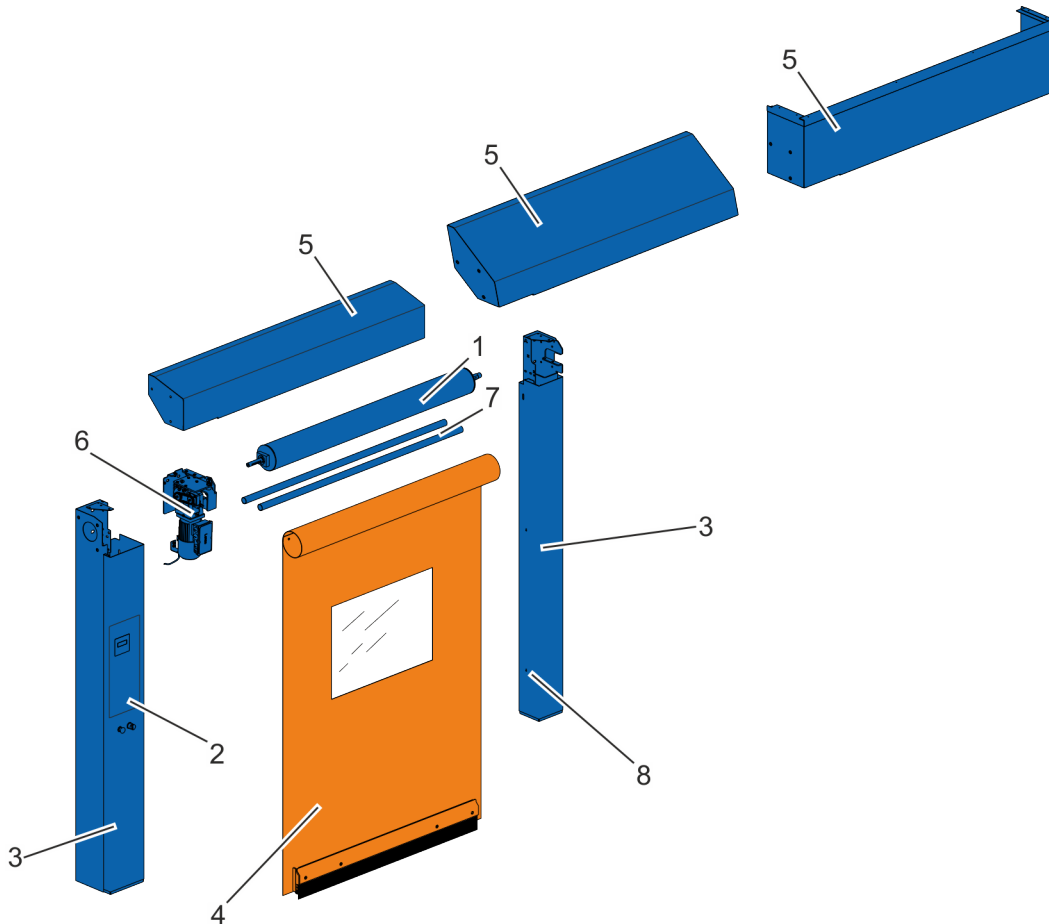

Fig. 7: Assemblies (254)

1	Winding shaft unit	↪ Page 18
2	Control unit with operating panel	↪ "Overview of control units", on page 34
3	Side frames with vertical door leaf guide, drum support and light barriers	↪ Further information on page 24 ↪ Further information on page 41
4	Door leaf with curtain	↪ Further information on page 26
	End shield and safety edge	↪ Further information on page 41
5	Winding shaft cover	↪ "Overview of the cover", on page 19
6	Drive	↪ Page 33
7	Horizontal lintel seal	↪ Page 31
8	Door light grid	↪ Further information on page 42

Construction of the high-speed roll-up door for clean rooms

Door system type 678

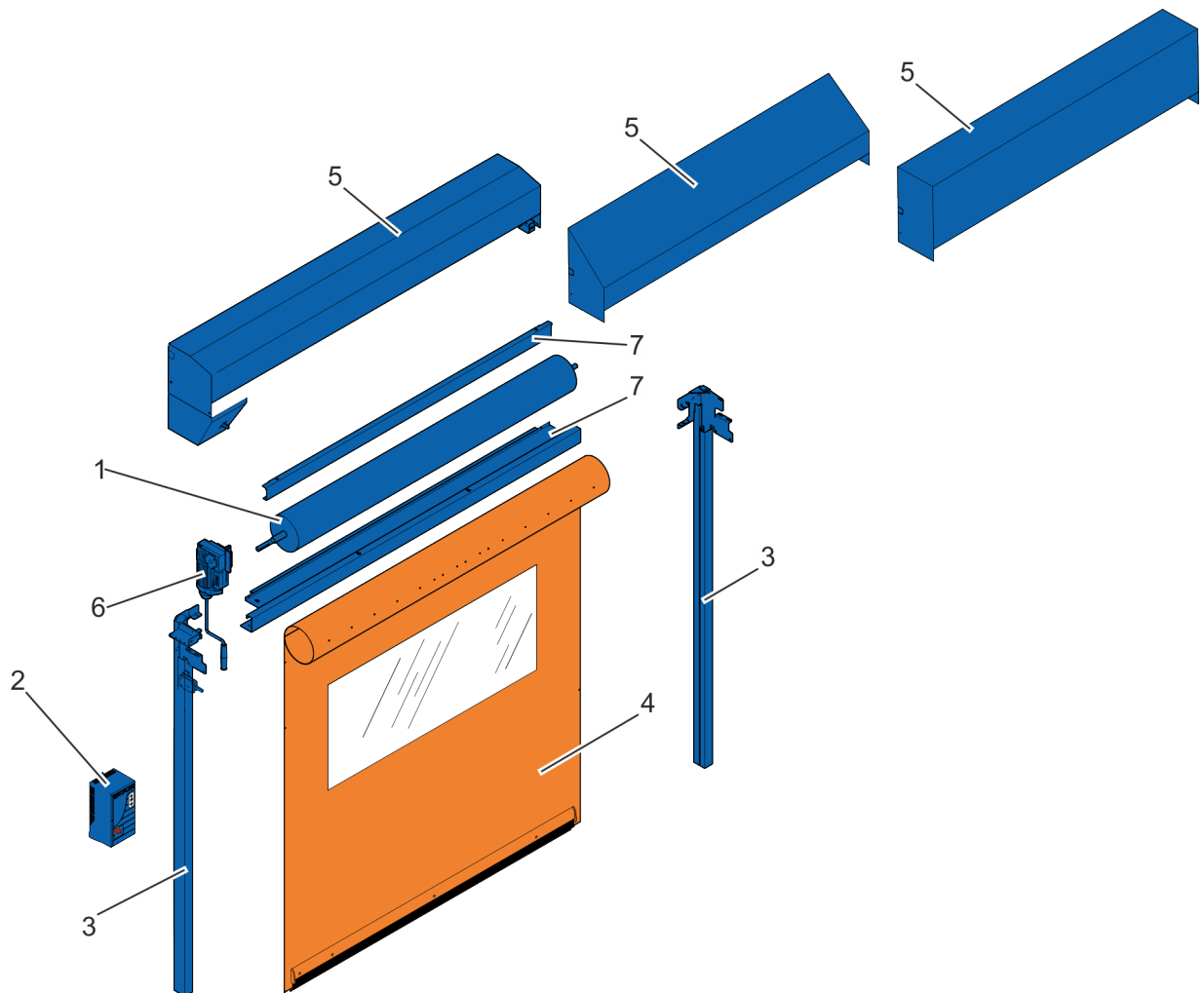

Fig. 8: Assemblies (678)

1	Winding shaft unit	↪ Page 18
2	Control unit with operating panel	↪ "Overview of control units", on page 34
3	Side frames with vertical door leaf guide, drum support and light barriers	↪ Further information on page 41 ↪ Further information on page 25
4	Door leaf with curtain	↪ Further information on page 26
	End shield and safety edge	↪ Further information on page 41
5	Winding shaft cover	↪ "Overview of the cover", on page 19
6	Drive	↪ Page 33
7	Horizontal lintel seal, flap seal	↪ Further information on page 31

Construction of the high-speed roll-up door for clean rooms

Door system type 679

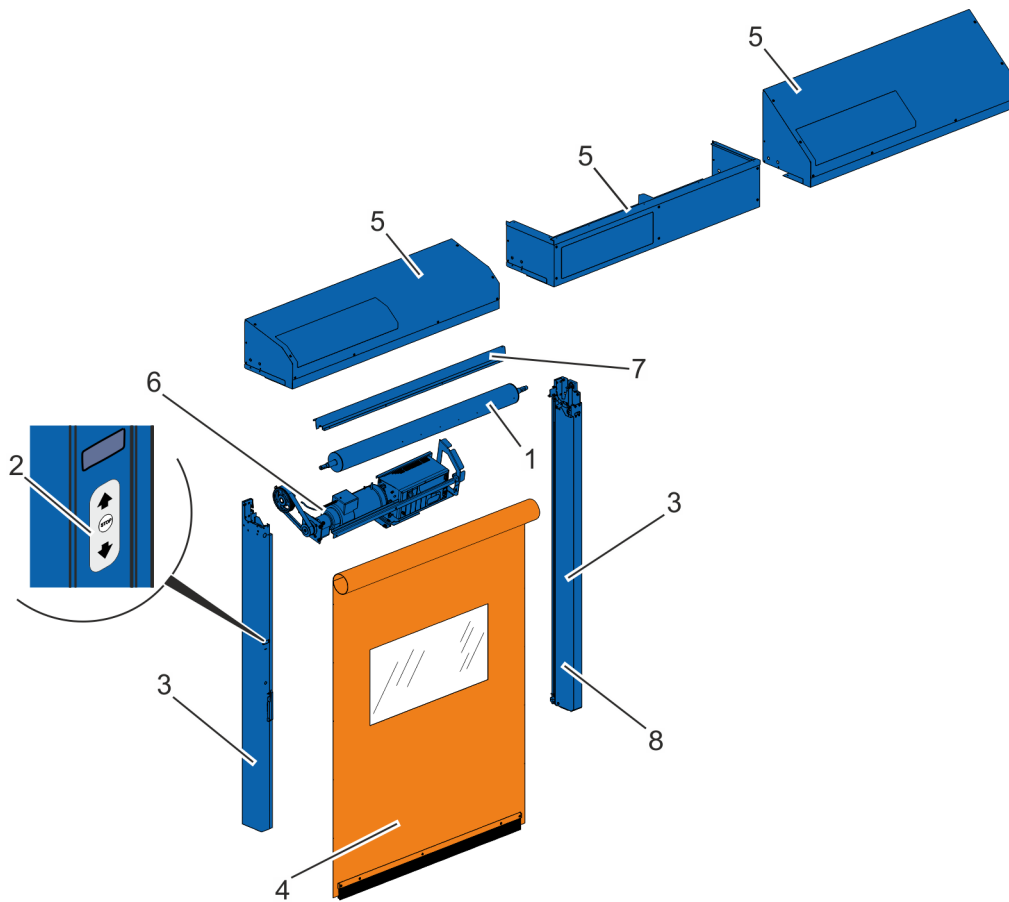

Fig. 9: Assemblies (679), ISO Class 6

1	Winding shaft unit	↪ Page 18
2	Operating panel	↪ Page 34
3	Side frames with vertical door leaf guide, drum support and light barriers	↪ Further information on page 41 ↪ Further information on page 25
4	Door leaf with curtain	↪ Further information on page 26
	End shield and safety edge	↪ Further information on page 41
5	Winding shaft cover	↪ "Overview of the cover", on page 19
6	Drive and control unit	↪ Page 34
7	Horizontal lintel seal	↪ Page 31
8	Door light grid	↪ Further information on page 42

Construction of the high-speed roll-up door for clean rooms

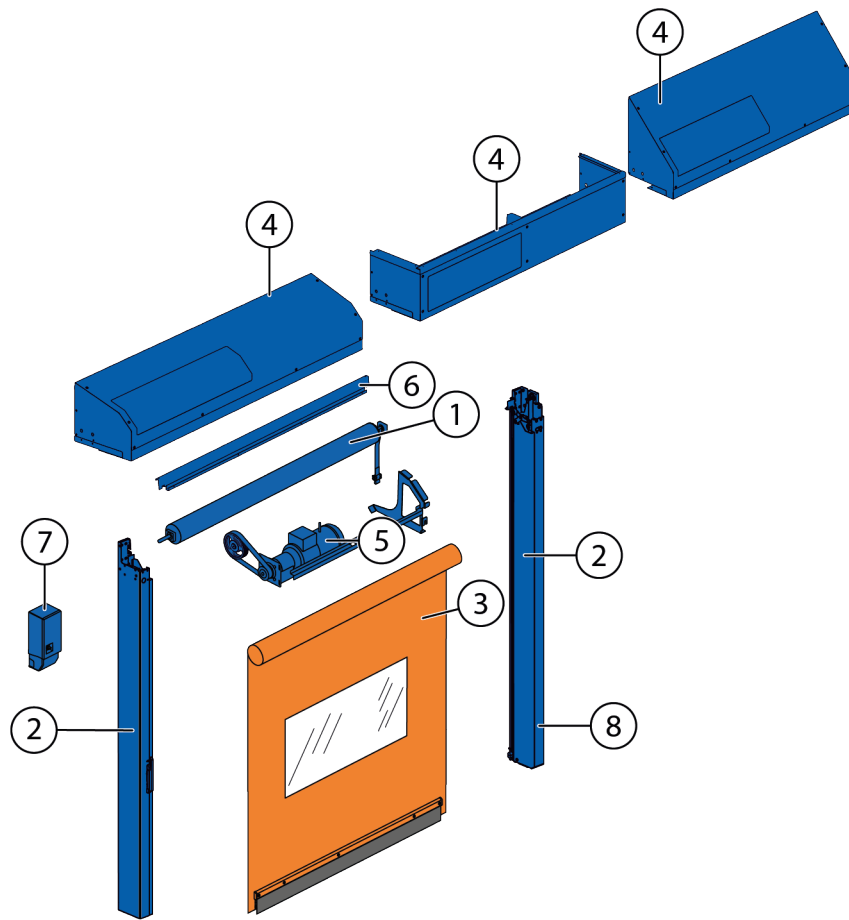

Fig. 10: Assemblies (679), ISO Class 7

1	Winding shaft unit	↪ Page 18
2	Side frames with vertical door leaf guide, drum support and light barriers	↪ Further information on page 25 ↪ Further information on page 41
3	Door leaf with curtain	↪ Further information on page 26
	End shield and safety edge	↪ Further information on page 41
4	Winding shaft cover	↪ "Overview of the cover", on page 19
5	Drive	↪ 'Drive 679' on page 34
6	Horizontal lintel seal	↪ Further information on page 31
7	Control unit	↪ 'Control unit' on page 34
8	Door light grid	↪ Further information on page 42

Construction of the high-speed roll-up door for clean rooms

Corrosion protection

3.1 Corrosion protection

Side frames

Frame surface	Selection in SAP	
	Z4/Powder coating	Z6/Stainless steel V2A
Design	<p>Steel, galvanised (275 g/m², with single-sided powder coating on the visible surface as per RAL (decorative surface coating)</p> <p>Coat thickness approx. 50 µm ± 10 µm</p> <p>Sheen level in compliance with DIN EN ISO 2813 (incidence angle 60°), 75 % ± 10 %</p> <p>Connecting components galvanised, not coated.</p>	<p>V2A 1.4301 stainless steel, corrosion resistant; polished grain 220, V2A connecting components</p> <p>V2A stainless steel, corrosion resistant; polished grain 220, V2A connecting components.</p>
Special features	<p>Sheet thicknesses</p> <ul style="list-style-type: none"> ■ ≤ 4 mm: sendzimir galvanised ■ > 4 mm: electrogalvanised 	<p>The tension springs (bright steel, oiled), the drive toothed belts (galvanised tension members) and various small parts cannot be made of V2A.</p>
Corrosion protection class as per DIN EN ISO 12944-6:2018	C3m	C5-I
Use	"Normal" industrial door	Industrial door in areas with high humidity and aggressive atmosphere

Duration of protection

l - low	short	up to 7 years
m - medium	medium	7 to 15 years
h - high	long	15 to 25 years
vh - very high	very long	> 25 years



*The corrosion protection design relates to the basic door construction, **not** to the drive.*

Construction of the high-speed roll-up door for clean rooms

Corrosion protection

Design of winding shaft

Door system type	Design
254	<ul style="list-style-type: none"> ■ V2A, corrosion resistant polished (grain 220) ■ optional steel primed
678	galvanised
679	steel, primed

Design of individual assembly parts

Assembly	Door system type	Z4/Powder coating finish as per RAL*, galvanised	Z6/Stainless steel V2A, corrosion resistant polished (grain 220)*
End shield	254	○	●
	678	●	○
	679	○	●
Cover	254	○	●
	678	●	○
	679	○	●
Design of door system	254	○	●
	678	●	○
	679	○	●

● Standard

○ Optional

* Except for:

- Drive with gear unit
- Weight in end shield
- Plastic parts
- Electrical parts
- Bearing with bearing housing
- Belt for spring

Construction of the high-speed roll-up door for clean rooms

Winding shaft unit

3.2 Winding shaft unit

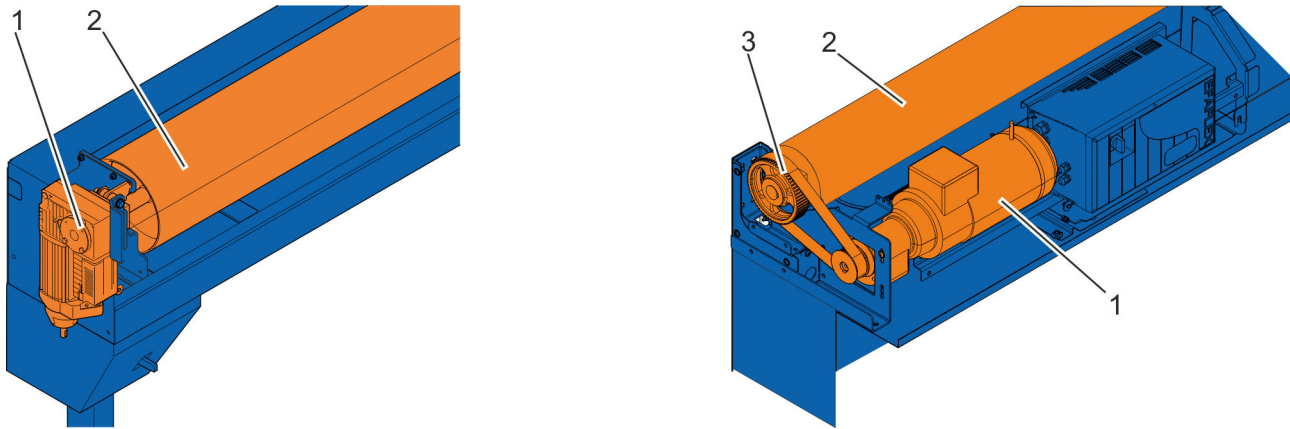

Fig. 11: Winding shaft unit 254/678 (left) and 679 (right)

The winding shaft unit comprises:

- Winding shaft (Fig. 11/2)
 - 254 (steel, primed), 679: tube \varnothing 159 x 4 mm
 - 254 (V2A): tube \varnothing 159 x 2 mm
 - 678: tube \varnothing 250 x 2 mm
- High-grade industrial bearings
- Drive (Fig. 11/1)
- Toothed pulley and toothed belt (Fig. 11/3)

3.3 Cover



Fig. 12: Winding shaft cover 254 (left), 678 (centre), 679 (right)

The winding shaft can be fitted with different covers depending on space requirements, functionality and the desired visual appearance. Three different options are available for the winding shaft cover:

- Motor cover (standard)
- 254, 678, 679: Winding shaft cover with 15° incline (standard)
- 254, 678: Winding shaft cover with 45° incline
- 679: Winding shaft cover with 40° incline
- Winding shaft cover vertical up to ceiling, available for ceiling heights

Type 254: From door system height + 460 mm to door system height + 1100 mm

Type 678: From door system height + 370 mm to door system height + 1100 mm

Type 679: From door system height + 380 mm to door system height + 1100 mm

3.4 Counterbalance

Counterbalance (254, 679)

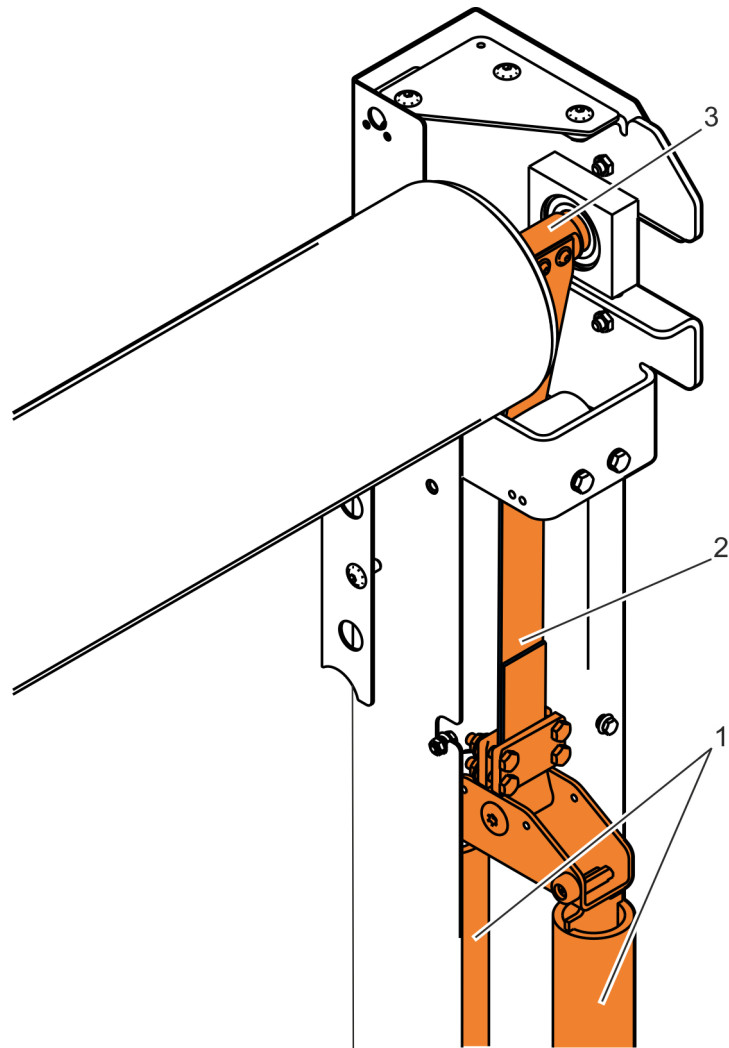

Fig. 13: Counterbalance

The door leaf is counterbalanced by a counter-pull mechanism: Tension springs (Fig. 13/1) are installed in the side frames. Heavy-duty belts (Fig. 13/2) connect them to the drive shaft (Fig. 13/3). The tension springs are tensioned when the door system is closed and relaxed when the door system is open.

This means that the door system can also be opened manually (without electrical power) in case of emergencies. In normal mode the motor is assisted by the force of the tension springs.

The spring tension is calculated on an order-specific basis.

Construction of the high-speed roll-up door for clean rooms

Emergency operation versions > Pull-button / illuminated push-button (254)

3.5 Emergency operation versions

Door system type	Manual release lever	Pull-button	Illuminated push-button	Manual emergency operation
254	–	●	○	–
678	–	–	–	●
679	●	–	–	–

- Standard
- Optional
- Not available

3.5.1 Pull-button / illuminated push-button (254)

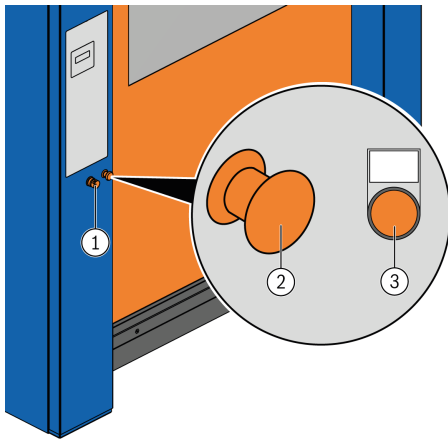

Fig. 14: Pull-button / illuminated push-button and emergency stop button

Emergency stop operating control (Fig. 14/1)	Standard
Pull-button (Fig. 14/2)	Standard
Illuminated push-button (Fig. 14/3)	Option (only available in conjunction with an independent emergency power supply (EFA-UPS))

In case of an emergency (power failure, etc.), the door system can be opened with little force using the pull-button (Fig. 14/2) or the illuminated push-button (Fig. 14/3). The pull-button and the illuminated push-button are not intended for routine opening of the door system.

An optional second pull-button or external illuminated push-button is available to make it possible to open the door system from both sides in case of an emergency.

When using an independent emergency power supply (EFA-UPS), a power failure is signalled when the illuminated push-button flashes white.

If the illuminated push-button lights up constantly, the rechargeable battery needs to be replaced.

Construction of the high-speed roll-up door for clean rooms

Emergency operation versions > Manual release lever (679)

3.5.2 Manual emergency operation (678)

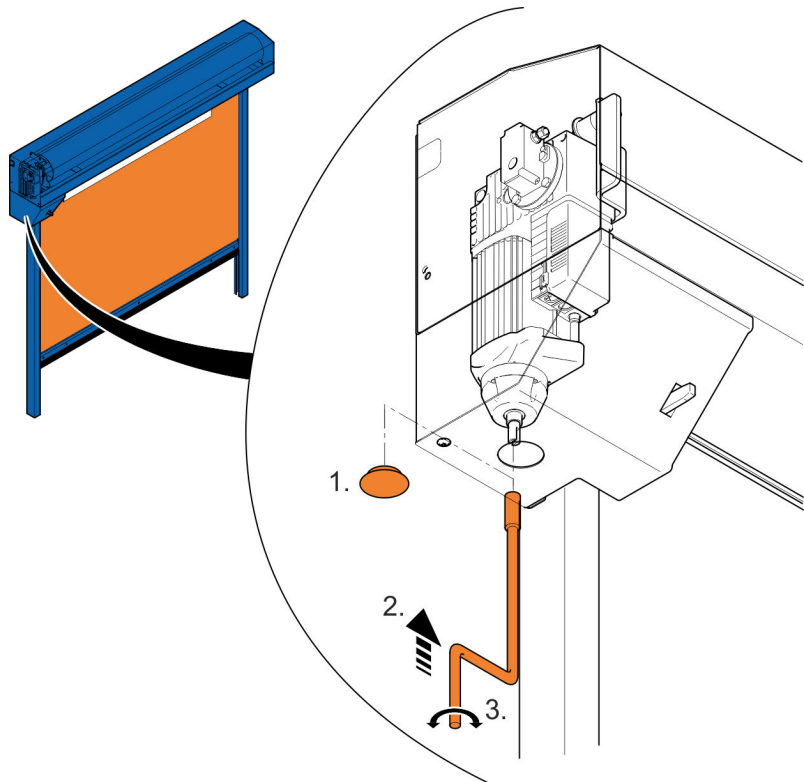

Fig. 15: Manual emergency operation

In case of power failure, the door system can be opened mechanically with the winch included in the scope of delivery.

3.5.3 Manual release lever (679)

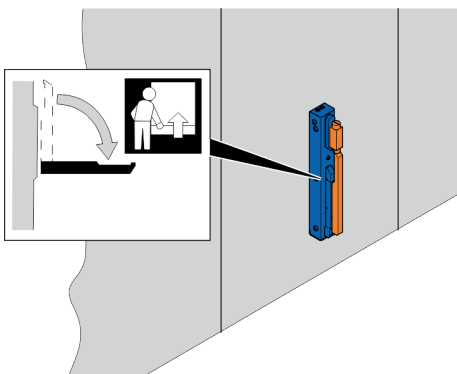

Fig. 16: Manual release lever on separate console

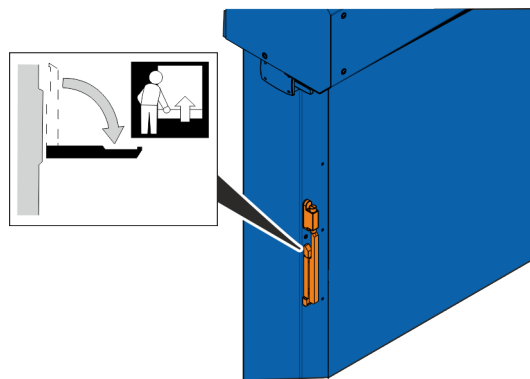

Fig. 17: Manual release lever on side frame

The manual release lever is situated on the side frame or optionally on a separate console. When the lever is pulled, the drive brake is enabled and the door system is partially opened automatically by the tension springs of the weight counterbalance system. The door can be opened completely by pushing the door leaf upwards manually.

The manual release lever is also available in a lockable design (optional).

3.5.4 Emergency stop operating control (254)

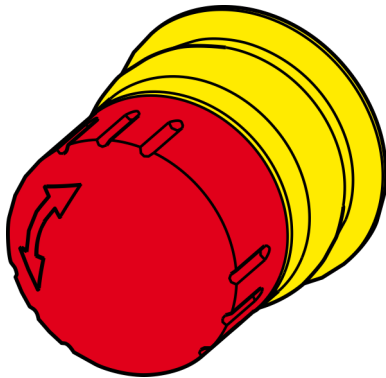

Fig. 18: Emergency stop operating control

Pressing the emergency stop operating control brings the door system to a controlled stop. The energy supply is maintained to affect the stoppage. After an emergency stop operating control has been pressed, it has to be released again by turning it to make it possible to continue operating.

3.5.5 Master switch

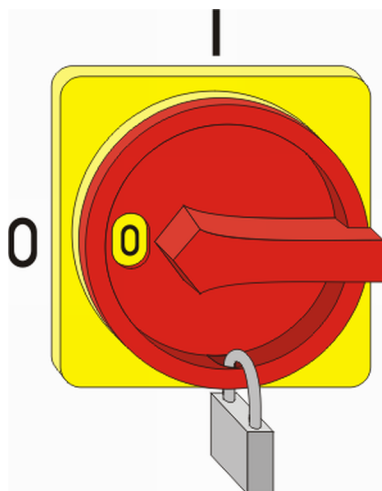

Fig. 19: Master switch

The master switch is used to isolate the entire door system from the voltage. Movements are stopped as quickly as possible and blocked until the master switch is reactivated. The master switch can be secured with a padlock to prevent it from being switched on without authorisation.

Construction of the high-speed roll-up door for clean rooms

Door leaf guide and side frames > Door system type 254

3.6 Door leaf guide and side frames

3.6.1 Door system type 254

The side frames each consist of one rectangular tube (Fig. 20/1) and one sheet metal cover profile (Fig. 20/2), which also form the guide, as well as one main sheet metal profile (Fig. 20/3).

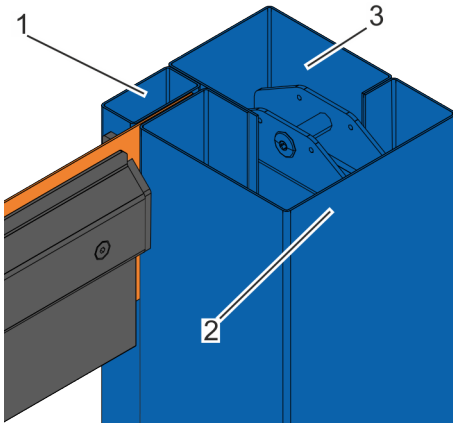

Fig. 20: Door leaf guide and side frame (254)

Side frame extension (optional) (254)

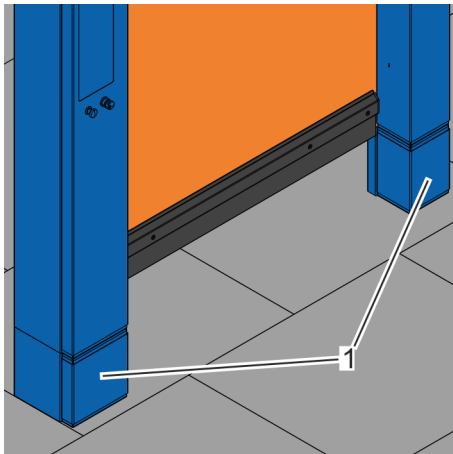
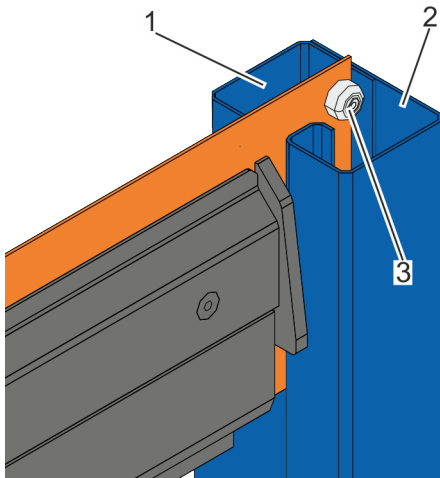

Fig. 21: Side frame extension (254)

With an optional side frame extension (Fig. 21/1), both side frames are extended but the door leaf maintains the same length. That means that the door leaf is not on the floor in the closed position but rather at the height of the original side frame length.

3.6.2 Door system type 678



Each side frame is made up of one main bevelled sheet metal profile (Fig. 22/1) and one bevelled sheet metal cover profile (Fig. 22/2). Together they form the door leaf guide. The wind nodes (Fig. 22/3) hold the door curtain in the guide.

Fig. 22: Door leaf guide and side frame (678)

3.6.3 Door system type 679

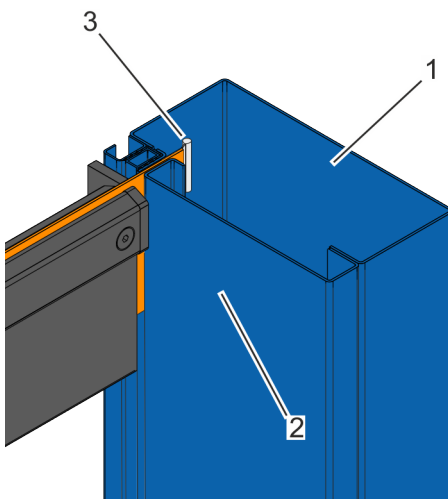

Each side frame is made up of one main bevelled sheet metal profile (Fig. 23/1) and one bevelled sheet metal cover profile (Fig. 23/2). Together they form the door leaf guide. The piped profiles (Fig. 23/3) hold the door curtain in the guide.

Fig. 23: Door leaf guide and side frame (679)

Construction of the high-speed roll-up door for clean rooms

Door leaf

Side frame extension (optional) (679)

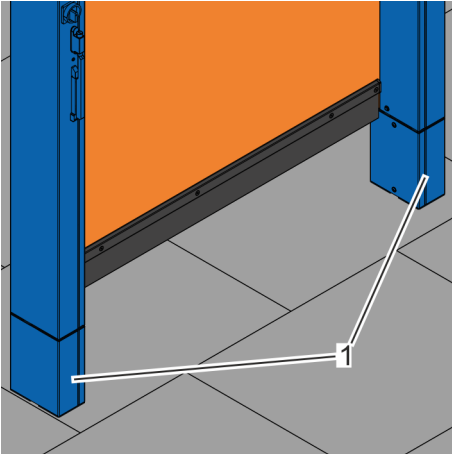

Fig. 24: Side frame extension (679)

With an optional side frame extension (Fig. 24/1), both side frames are extended but the door leaf maintains the same length. That means that the door leaf is not on the floor in the closed position but rather at the height of the original side frame length.

3.7 Door leaf

The flexible door leaf is permanently connected to the winding shaft. The drive moves the winding shaft, causing the door leaf to be wound up when opening and unwound when closing. During winding, the door leaf is guided within the frame sides.

An end shield forms the end of the door leaf. The door leaf is tensioned by the weight of the end shield.

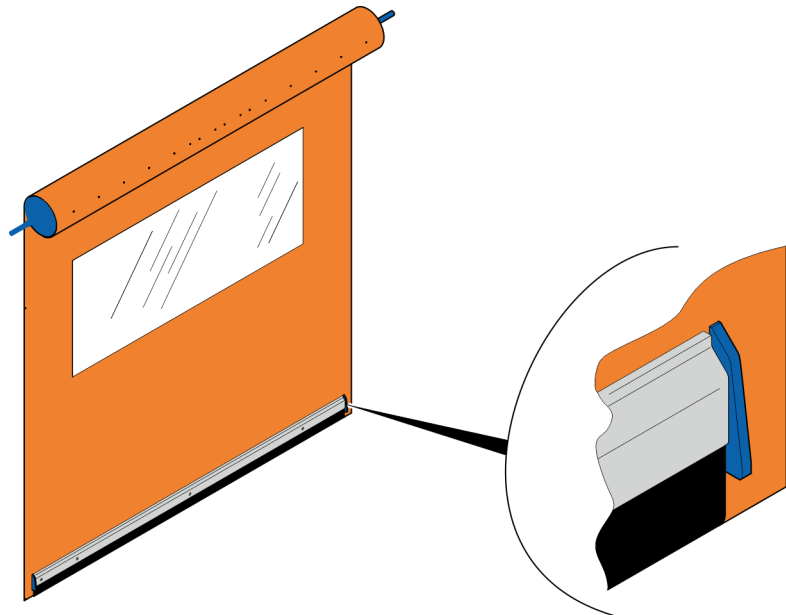

Fig. 25: Door leaf

3.7.1 Door leaf versions

Curtain made of PVC-coated polyester fabric, laterally stable (TO1/TS1/TO5/TS5)

The curtain is made of 2 mm thick Transilon material. The curtain can be fitted as an option with a 2 mm thick soft PVC viewing window that is welded together to the Transilon material.

The curtain forms a flat surface with the viewing window.

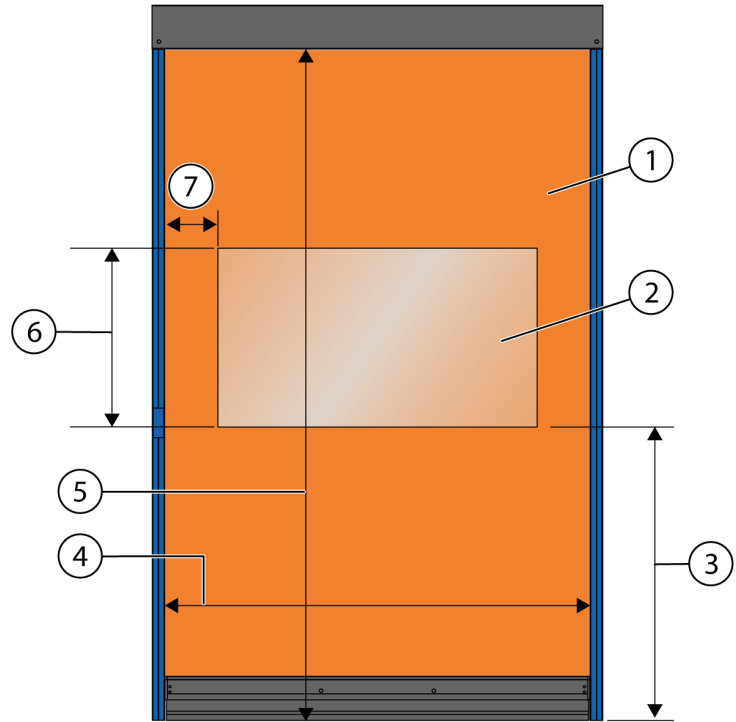

Fig. 26: Curtain made of PVC-coated polyester fabric, laterally stable (TO1/TS1/TO5/TS5)

- 1 2 mm thick curtain
- 2 2 mm thick viewing window made of soft PVC
- 3 Distance from the closing level to the viewing window (MBFEN/MBF), depending on the size of the door system
- 4 Door system width
- 5 Door system height
- 6 Viewing window height (FENH/FHR), 150 mm to 1,400 mm, depending on the size of the door system
- 7 2 mm thick lateral stripes, see the table for dimensions ↪ 'Lateral stripes' on page 27

Lateral stripes

Door system type	Fig. 26/7	
	B < 1300 mm	B ≥ 1300 mm
254	134 mm	334 mm
678	150 mm	350 mm
679	162 mm	362 mm

Construction of the high-speed roll-up door for clean rooms

Door leaf > Door leaf versions

Equipment		Door system type		
		254	678	679
2 mm thick curtain made of PVC-coated polyester fabric, laterally stable, textured on both sides, with and without viewing window (TOX/TSX) (Viewing windows not at temperatures of < 5 °C)	Blue Similar to RAL 5002 ^{1,2}	•	•	•
	Yellow Similar to RAL 1021 ²	•	•	•
	Orange Similar to RAL 2008 ²	•	•	•
	Red Similar to RAL 3002 ²	•	•	•
	Papyrus white Similar to RAL 9018 ^{1,2}	•	•	•
	Light grey Similar to RAL 7035 ^{1,2}	•	•	•
	Signal grey Similar to RAL 7004 ^{1,2}	•	•	•
	Moss green Similar to RAL 6005 ^{1,2}	•	•	•
	Pure white Similar to RAL 9010 ^{1,2}	•	•	•
	Anthracite Similar to RAL 7016 ^{1,3}	•	•	•

• Standard

○ Optional

– Not available

¹ Anti-static finish

² Complies with the regulations of FDA 21CFR §175.300 (Table 2, D) for contact with aqueous foods (contact period of 30 minutes at 40 °C). Oily and fatty foods are excluded (applies only partially to door curtain with viewing window).

³ Flame retardant in compliance with DIN EN ISO 340

All curtains meet the requirements for Zone III LABS conformity (substances preventing paint adhesion) in accordance with VDMA 24364.

Construction of the high-speed roll-up door for clean rooms

Door leaf > Door leaf versions

Curtain made of polyester fabric with urethane water proofing, laterally stable (TO4)

The curtain is made of 1.4 mm thick Transilon material. A viewing window cannot be supplied with the curtain.

This curtain is specifically designed for use in areas where food-stuffs are handled. Complies with the following regulations or directives for transportation of unpacked foodstuffs:

- (EU) 10/2011 and Regulation (EC) 1935/2004
- FDA 21CFR
- MHLW 370
- Halal

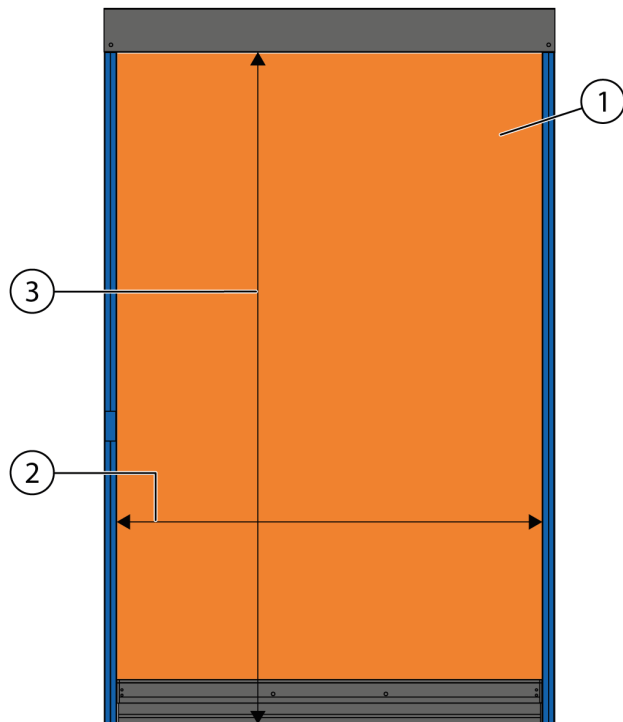

Fig. 27: Curtain made of polyester fabric with urethane water proofing, laterally stable (TO4)

- 1 1.4 mm thick curtain made of sheet with PES fabric
- 2 Door system width
- 3 Door system height

Equipment		Door system type		
		254	678	679
1.4 mm thick curtain, made of polyester fabric with urethane water proofing, laterally stable, textured on both sides, without viewing window (TO4)	Beige ¹	○	○	—

- Standard

Construction of the high-speed roll-up door for clean rooms

Door leaf > Door leaf versions

- Optional

- Not available

¹ Anti-static finish (applies only partially to door curtain with viewing window)

4 Seal

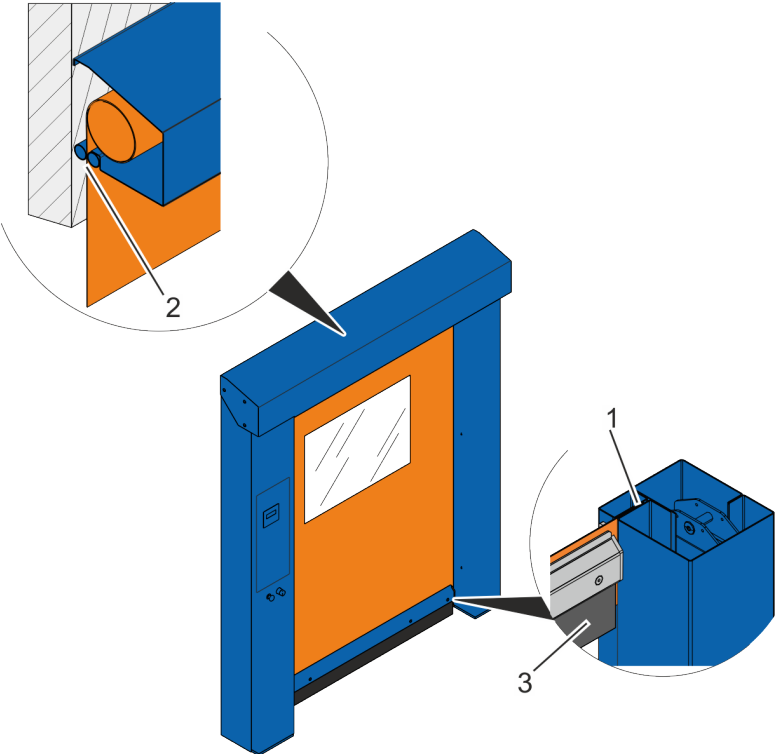

Fig. 28: Seal 254

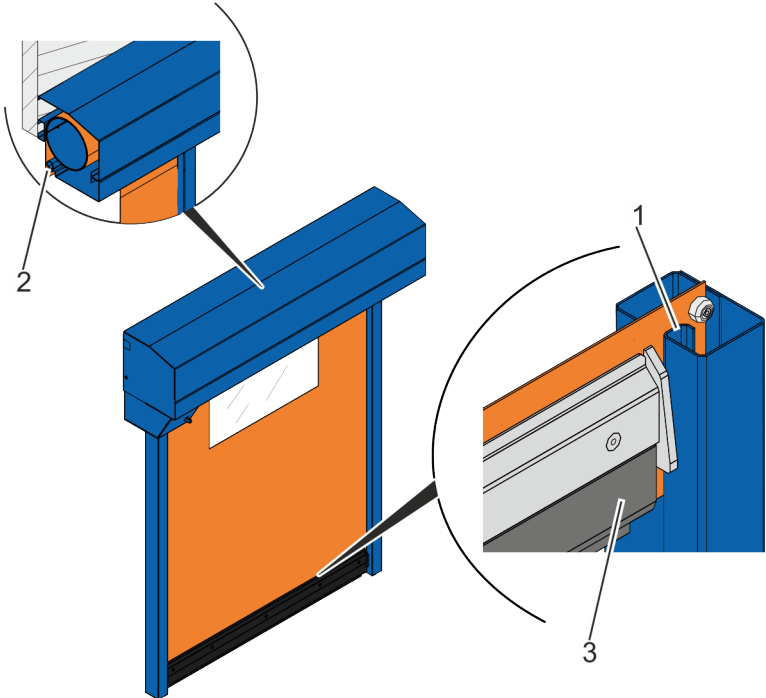

Fig. 29: Seal 678

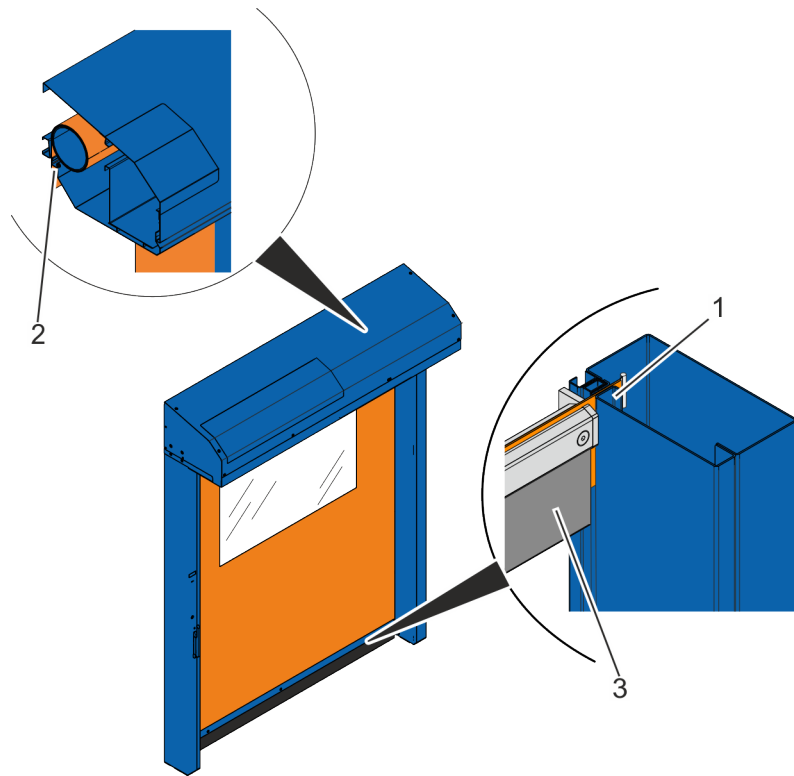

Fig. 30: Seal 679

Item number	Designation
1	Door leaf guide
2	Horizontal profiles
3	Rubber profile

The sealing effect is produced by the principle of surface pressure. The positive or negative pressure presses the curtain against the door leaf guides and the horizontal profiles. The curtain runs through the end shield, which has a two-part design, and in the guides at the side. At floor level, the door system is sealed off by the rubber profile.

For design reasons, the rubber profile is narrower than the door width. The rubber profile is the same length as the end shield (door width-sliding pieces-guide gap). In this area, the curtain is guided almost to the floor to close the technical gap.

The door connections are sealed by pre-compressed packing cord. When the door system is opened, the air pressure in the rooms immediately equalises and the curtain hangs freely in the guides again so that the door system can be opened without the curtain scraping in the guides.

5 Drive and control unit

Drive 254

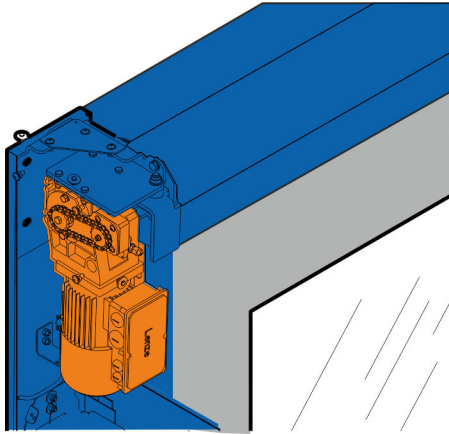

Drive type	Direct mount drive (Spur gear, asynchronous AC motor)
Power classes	0.55 kW
Power supply	230 V
Protection type	IP54
Position detection	Absolute encoder. Thus no reference run is required.

Fig. 31: Drive 254

Drive 678

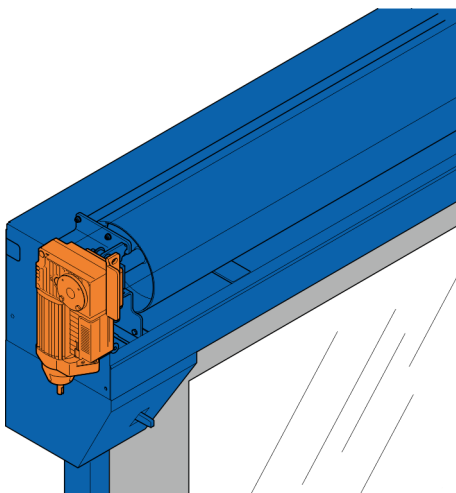

Drive type	Direct mount drive (Worm gear, asynchronous AC motor)
Power classes	1.1 kW
Power supply	230 V
Protection type	IP54
Position detection	Absolute encoder. Thus no reference run is required.

Fig. 32: Drive 678

Drive and control unit

Drive 679

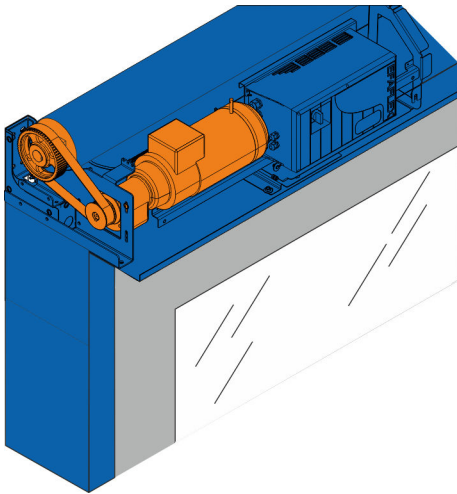

Drive type	Power transmission via toothed belt (Spur gear, asynchronous AC motor)
Power classes	1.5 kW
Power supply	230 V
Protection type	IP54
Position detection	Absolute encoder. Thus no reference run is required.

Fig. 33: Drive 679

Control unit

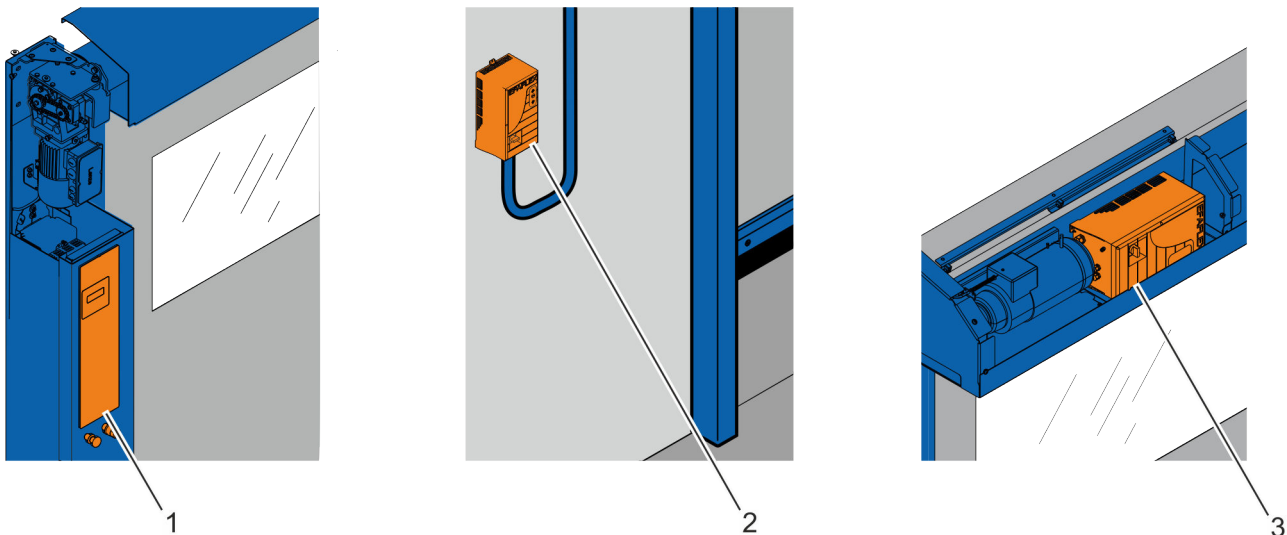

Fig. 34: Position of control units

Door system type	Integrated into frame (Fig. 34/1)	Next to side frame (Fig. 34/2)	Behind cover (Fig. 34/3)
254	•	–	–
678	–	•	–
679	–	• (only for ISO 7)	• (only for ISO 6)

- Standard
- Optional
- Not available

EFA-TRONIC®

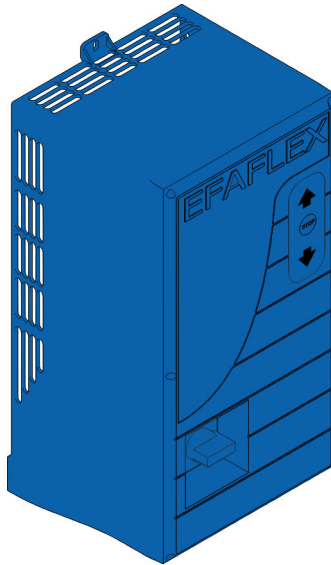

Fig. 35: EFA-TRONIC®

Control unit	EFA-TRONIC® with frequency converter
Size (W × H × D)	210 × 400 (565)* × 200 mm (* incl. cable cover)
Housing	Polycarbonate housing
Protection type	IP65
Viewing window for display	Display of status messages and fault messages
Operating controls	Operating panel for operation and configuration of the door system Master switch
Supply voltage	L/N/PE 230 V ± 10 % or 3~L/N/PE 400 V ± 10 %
Frequency	50 – 60 Hz
Supply cable	Fuse protection 16 A to be provided by the user (K characteristic)
With residual current device (RCD) as necessary	300 mA in compliance with DIN VDE 0100-530 (sensitive to universal current)

EFA-HDI® operating unit

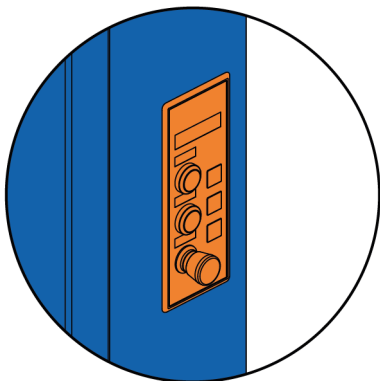

Fig. 36: EFA-HDI® operating unit

It is possible to install an additional operating unit to supplement the EFA-TRONIC®. It is equipped with a display screen and offers full access to all parameters and all basic functions.

Special constructions

Special constructions/special orders are design types which are not covered, either mechanically or electrically, by standard versions in the sales price lists or by a design from the technology variants table. They have to be requested specifically. Surcharges and extended delivery times are calculated for special designs in accordance with the actual expenditure.

Optional assembly groups

Limit switch (254 only)

6 Optional assembly groups

6.1 Limit switch (254 only)

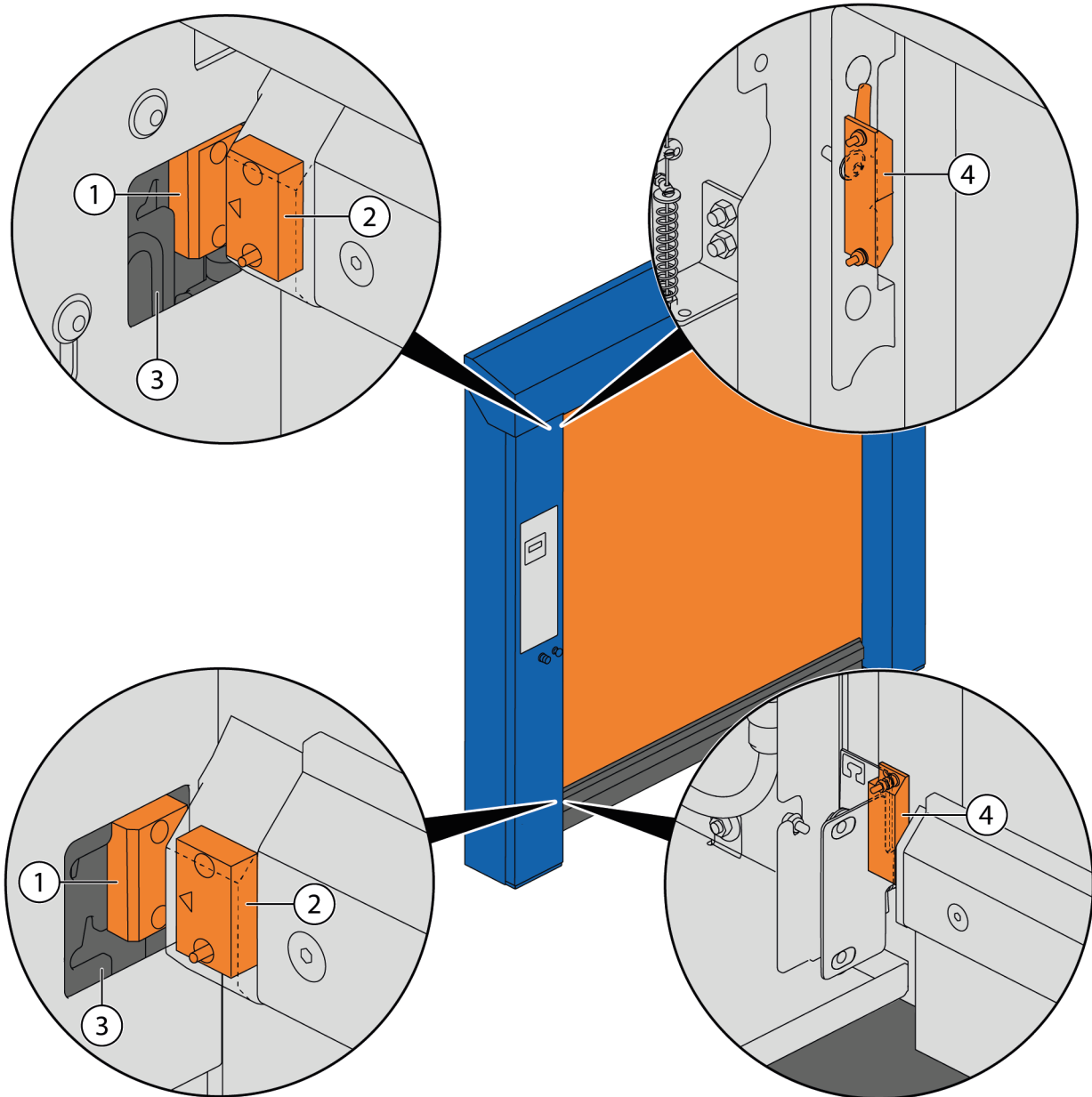

Fig. 37: Limit switch overview

Safety limit switch

- The locking mechanism (Fig. 37) for monitoring the safe end position allows connection to the system/machine control unit and is a cat. 4 / PL "e" design in accordance with DIN EN ISO 13849-1.

There is a recess in the side frame to guarantee the functionality of the safety limit switch (Fig. 37/1). A flush-mounted polycarbonate plate (Fig. 37/3) is installed here. The actuator is located in the sliding block (Fig. 37/2).

Magnetic limit switch

- The magnetic limit switch (Fig. 37/4) is used to monitor the end positions and allows connection to the system/machine control unit.

The following end positions can be monitored:

- Door closed
- Door open

Optional assembly groups

LED display/traffic lights (254 only)

6.2 LED display/traffic lights (254 only)

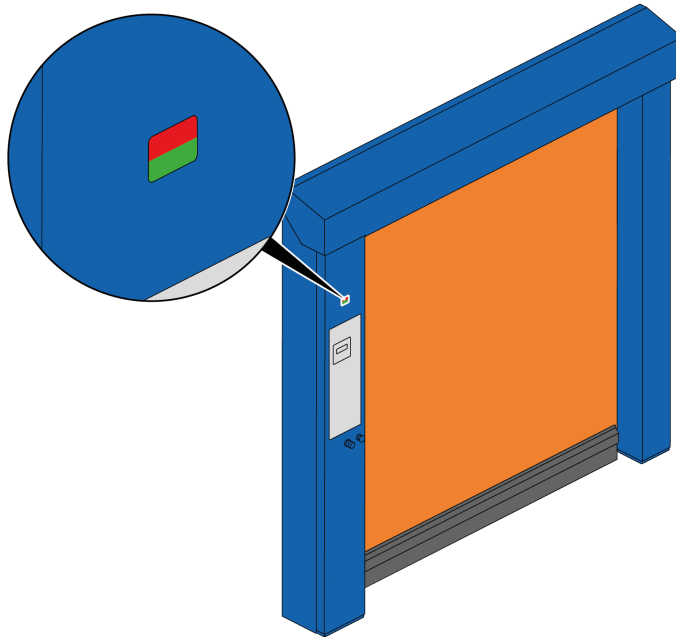

Fig. 38: Traffic lights

The LED display/traffic lights are flush-mounted above the control cabinet cover and indicate whether it is safe to pass through the door system.

If the lower half of the display is lit in green, the door system is completely open and can be passed through.

If the upper half of the display is lit in red, the following causes are possible:

- The door system is currently closing
- The door system is closed
- The door system is currently opening
- Traffic from the other direction is expected

If the upper half of the display is flashing in red, the following causes are possible:

- The door system is currently closing
- The door system is closed
- The door system is currently opening
- Traffic from the other direction is expected
- There is a fault with the door system

6.3 Selector switch



Fig. 39: Selector switch

Selector switches can be adapted to individual requirements and used for various functions.

6.4 Key switch

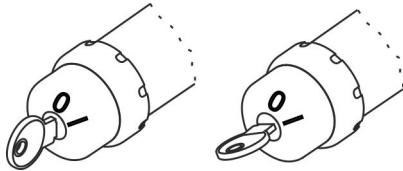

Fig. 40: Key switch

Operating the key switch opens or closes the door system.

6.5 Contactless switch

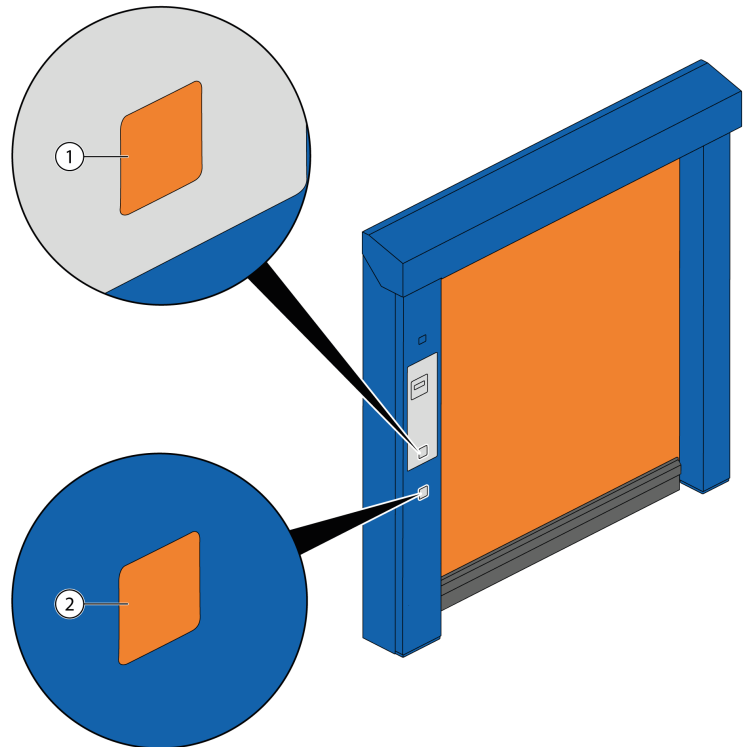

Fig. 41: Integrated contactless switch (254 only)

A simple hand movement in front of the sensor opens the door system.

The following installation versions are possible:

- Flush-mounted in the control cabinet cover or in the side frame behind a polycarbonate plate (Fig. 41/1 and Fig. 41/2) (254 only)
- Externally, wall mounted or flush mounted

Optional assembly groups

Infrared presence detector (254 only)

6.6 Infrared presence detector (254 only)

The infrared presence detector detects people and vehicles and safeguards the approach area and/or acts as a variable signalling device.

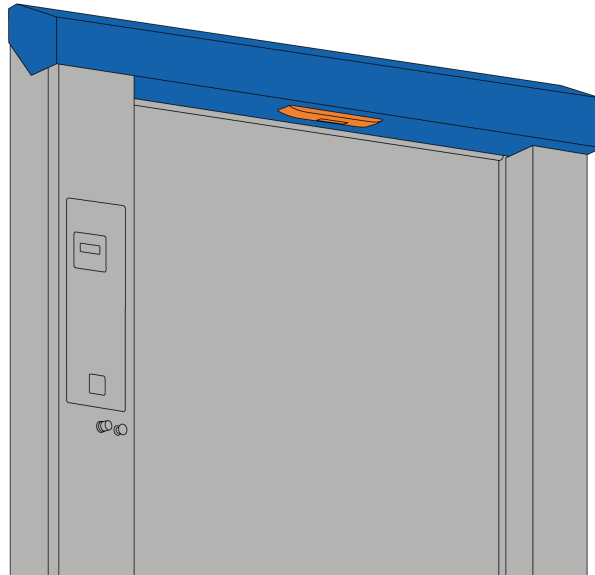

Fig. 42: Infrared presence detector

The following installation versions are possible:

- Integrated into cover
- On opposite side of door

7 Door safety

Safety devices

Door system type	Safety edge	Light barrier	Door light grid
254	●	○	○
678	●	○	–
679	–	–	●

- Standard
- Optional
- Not available

7.1 Safety edge and light barrier

The main closing level is secured by a combination of a safety edge and a light barrier (C device plus D device). This achieves the minimum protection level specified by EN 12453.

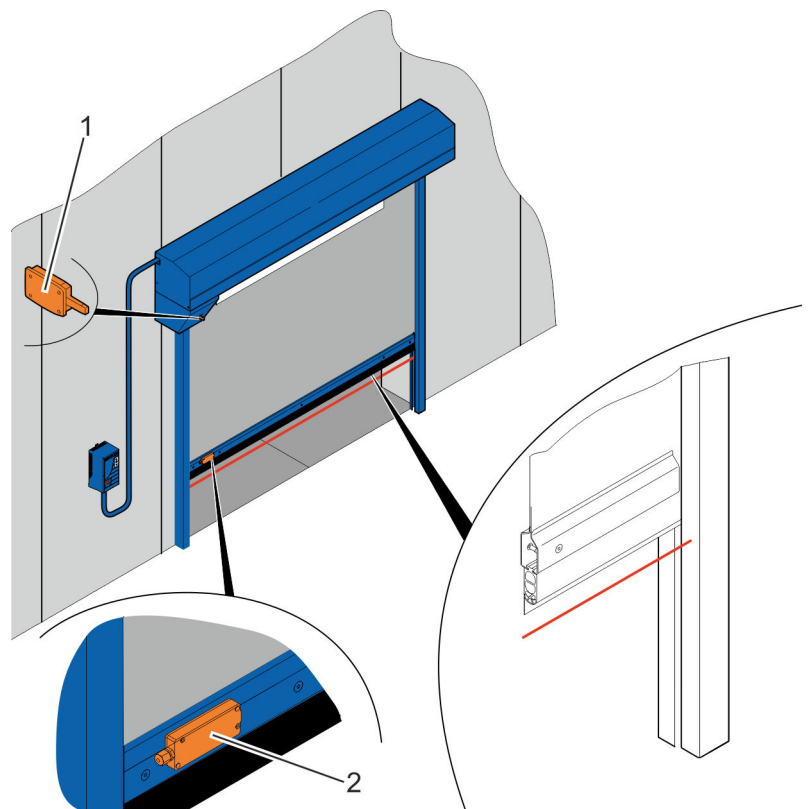

Fig. 43: Safety edge and light barrier

- 1 Radio receiver for safety edge
- 2 Radio transmitter for safety edge

Door safety

Door light grid

Safety edge	Safety edge with radio transmission (the 2 lithium batteries (3.6 V) of the transmitter must be changed annually)
Light barrier	Light barriers (IP67) installed in the side frame, max. 2

The safety edge complies with the requirements set out in the product standard for doors, DIN EN 13241. In addition, the owner and the manufacturer must consult with one another to provide a safeguard for the approach area. This is based on the owner's risk assessment.

7.2 Door light grid

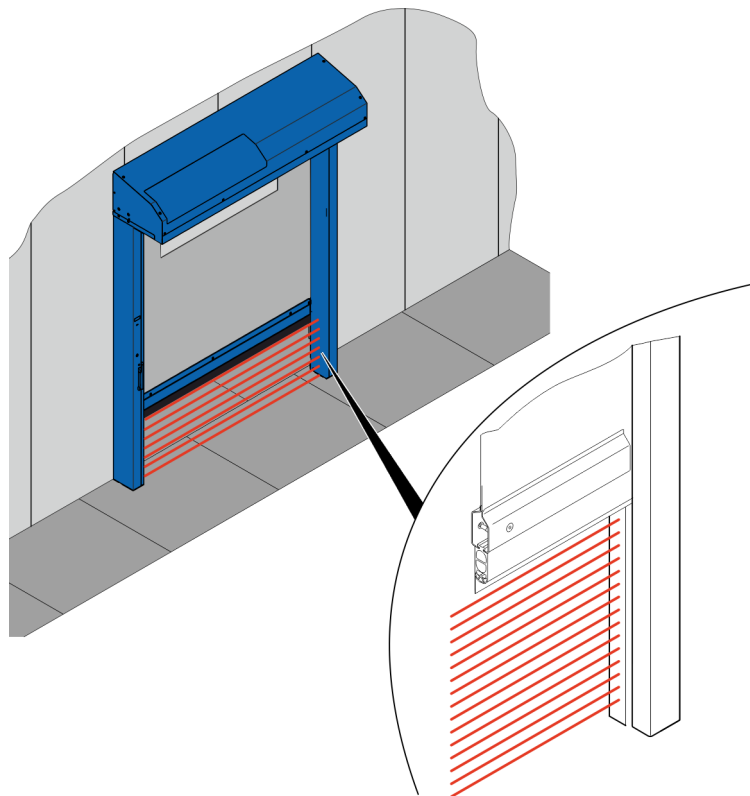

Fig. 44: Door light grid

The door light grid, which is installed in the side of the side frame, monitors the closing level, up to a height of 2.5 metres. The door light grid prevents the door system from closing when a person is detected in the danger area.

On door systems, an optional safety edge can be installed in addition to the door light grid.

Simultaneous installation of a door light grid and light barrier is not possible.

8 Packaging units

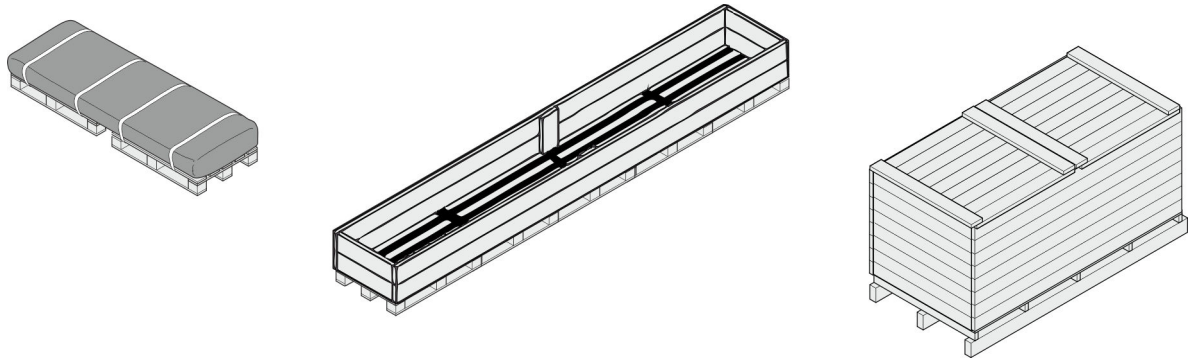

Fig. 45: Scope of delivery for 254/679 (left, standard transport unit) and 678 (middle, transport unit), wooden crate (right, optionally for sea and fit-for-purpose* transport)



**Fit-for-purpose packaging is packaging which ensures that the packaged goods reach the recipient without damage, taking into account the shipping loads, shipping route, shipping duration and transportation load profile.*

Transport unit (example)

Side frames, drive and control unit, winding shaft including door leaf, winding shaft cover (optional) and optional accessories

Number of transport units

The number of standard transport units depends on the selected number of door systems.

The door systems can also be delivered in a wooden crate. The number of wooden crates depends on the configuration of the door system types and the number of door systems.

Wood that complies with the IPPC standard is optionally available. For sea freight, the wooden crates are lined with film as protection against moisture.

Packages fastened to pallets can be transported by forklift under the following conditions:

- The forklift must have the appropriate capacity for the weight of the packages.
- The package must be securely fastened to the pallet.
- The forklift driver must be authorised to drive industrial trucks with a driver's seat or driver's station in accordance with the local regulations.



EFAFLEX Tor- und Sicherheitssysteme

GmbH & Co. KG

Fliederstrasse 14

84079 Bruckberg

GERMANY

Telephone: +49 8765 82-0

Fax: +49 8765 82-200

Email: info@efaflex.com

Internet: www.efaflex.com