



***Technical product description***  
***High-speed spiral door***  
***Low lintel***



*For internal use only*

This technical product description  
applies to the following door system types:

EFA-SST®-L N Premium

EFAFLEX Tor- und Sicherheitssysteme GmbH & Co. KG

Fliederstraße 14

84079 Bruckberg

GERMANY

Telephone: +49 8765 82-0

Fax: +49 8765 82-200

Email: [info@efaflex.com](mailto:info@efaflex.com)

Internet: [www.efaflex.com](http://www.efaflex.com)

Translation of the original

Version 01-EN

01.04.2025

© EFAFLEX Tor- und Sicherheitssysteme GmbH & Co. KG

**Door system designations**

<b>Official designation of the door system</b>	<b>Spiral type</b>	<b>Designation of the door system in this product description</b>	<b>Installation drawing (EZ) number</b>
EFA-SST®-L N Premium	Low lintel	307	005-xx

## Table of contents

<b>1</b>	<b>Short description</b> .....	<b>5</b>
<b>2</b>	<b>Technical properties</b> .....	<b>7</b>
	2.1 Use.....	7
	2.2 Dimensions.....	7
	2.3 Speeds.....	8
	2.4 Performance properties.....	8
	2.5 Fire performance.....	8
	2.6 Safety standards.....	9
	2.7 Use.....	9
<b>3</b>	<b>Construction of the high-speed spiral door</b> .....	<b>10</b>
	3.1 Spiral case.....	12
	3.2 Cover versions of the spiral case and horizontal guide.....	13
	3.2.1 Spiral case covers.....	14
	3.2.2 Securing the horizontal guide.....	15
	3.2.3 Height-dependent protective guard.....	16
	3.3 Transmission of force.....	18
	3.4 Side frames.....	18
	3.4.1 Counterbalance.....	19
	3.4.2 Manual release lever.....	20
	3.4.3 Door locking mechanism.....	21
	3.4.4 Door leaf guide.....	26
	3.4.5 Side frame extension.....	27
	3.4.6 Flexible closing strip extension.....	28
	3.4.7 Rigid closing strip extension.....	30
	3.4.8 End positions.....	31
	3.4.9 Spring or belt break detector.....	34
	3.5 Resistance class.....	34
	3.6 Door leaf, laths and door leaf design.....	36
	3.6.1 Corrosion protection.....	43
	3.7 Seal.....	47
	3.8 Drives.....	48
	3.9 Control units.....	48
<b>4</b>	<b>Door safety</b> .....	<b>52</b>
	4.1 Door light grid.....	52
	4.2 Safety edge and light barrier.....	53
	4.3 EFA-SCAN®.....	54
<b>5</b>	<b>Equipment packages</b> .....	<b>55</b>
<b>6</b>	<b>Surface design drawings</b> .....	<b>57</b>
	6.1 Component coating type.....	58
	6.2 Stainless steel design components (V2A).....	61
<b>7</b>	<b>Packaging units</b> .....	<b>68</b>

## 1 Short description

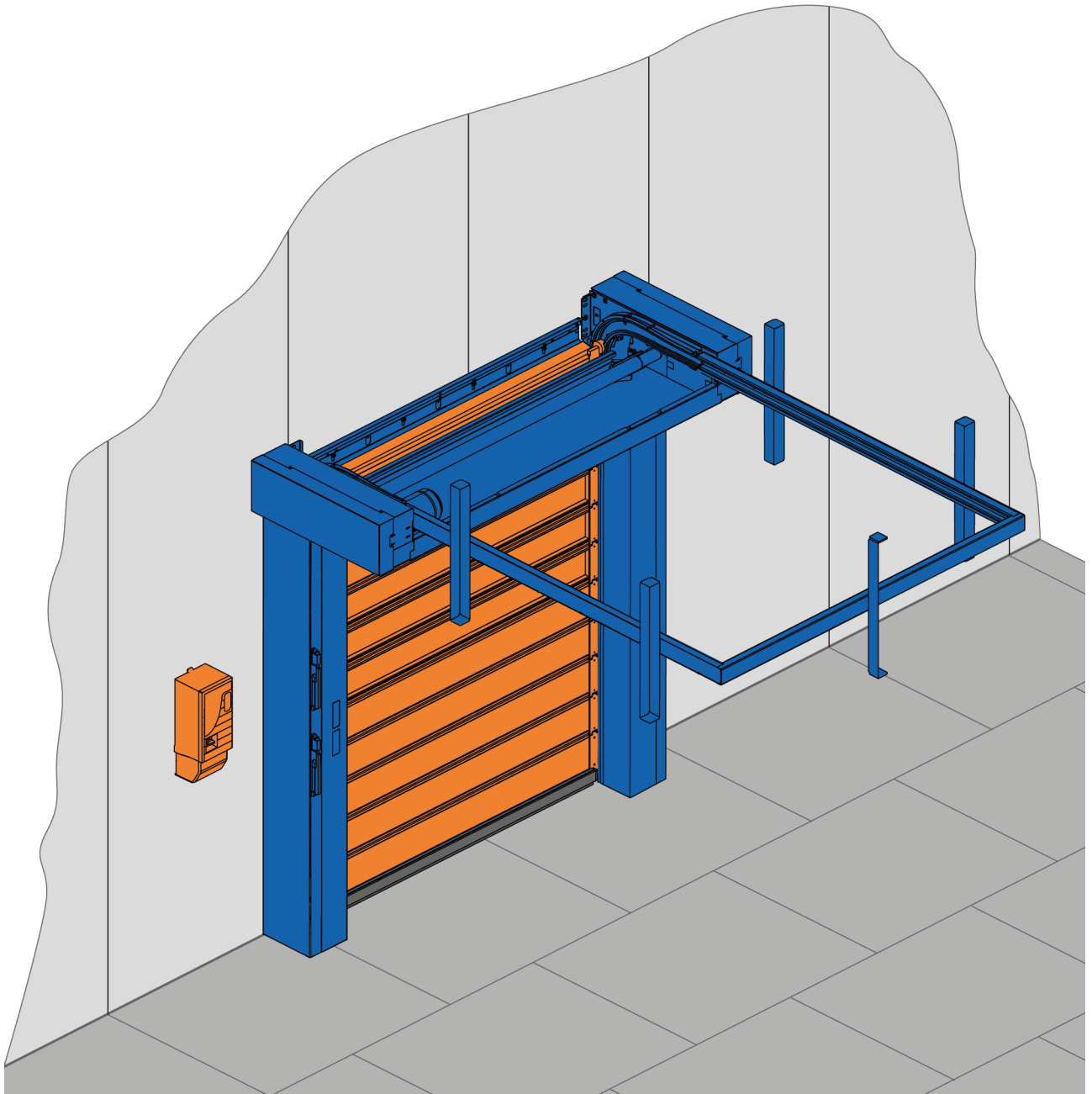

*Fig. 1: High-speed spiral door*

S series high-speed spiral doors are door systems designed for industrial and commercial purposes. The special door leaf guide allows a minimum lintel height requirement and enables high operating speeds.

## Short description

The EFA-SST®-L N Premium features a 40 mm thick door leaf with a spacing of 225 mm. Thanks to the special door leaf guide, the door leaf achieves high speeds with excellent smoothness of operation.

## 2 Technical properties

### 2.1 Use

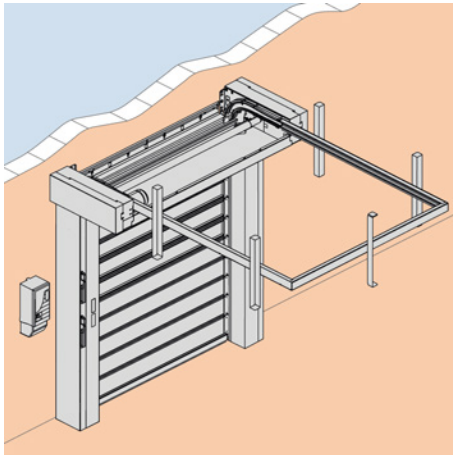

Fig. 2: Use

#### Use

- Industrial door
- Hall door
- Outdoor installation under a canopy provided by the owner possible
- Interior door

	Outdoors (-15 °C to +50 °C)
	Indoors (+5 °C to +50 °C)



The control unit must be installed in an ambient temperature of > +5 °C.

See [↗ Control cabinet heating on page 55.](#)

### 2.2 Dimensions

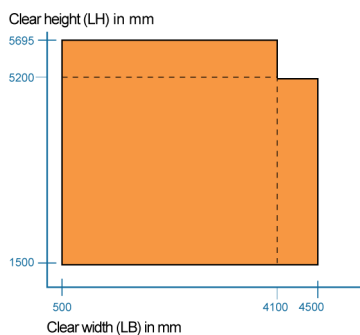

Fig. 3: Diagram of possible door system heights and widths

#### Door system heights and widths

Door system type	Clear width (LB)	Clear height (LH)
307	500 – 4500 mm	1500 – 5695 mm



The door size depends on the door leaf design.

## Technical properties

Fire performance

### 2.3 Speeds

Door system type	Average speed (max. speed)		
	Opening speed	Closing speed with door light grid	Closing speed with safety edge and light barrier
307	2.0 m/s (2.3 m/s)	1.00 m/s	0.60 m/s

The speeds depend on the door system dimensions, particularly the door system height.

If the horizontal guide is secured with the light grid (see Fig. 10), the opening speed is reduced (1.5 m/s).

### 2.4 Performance properties

Performance features in accordance with DIN EN 13241

Door system type	Specification	Door system width/size, other specifications	Value
307	Resistance to wind load in compliance with DIN EN 12424	$500 \text{ mm} \leq \text{LB} \leq 3300 \text{ mm}$	Class 4
		$3301 \text{ mm} \leq \text{LB} \leq 4000 \text{ mm}$	Class 3
		$4001 \text{ mm} \leq \text{LB} \leq 4500 \text{ mm}$	Class 2
	Resistance to water ingress in compliance with DIN EN 12425	-	Class 2
	Air permeability in compliance with DIN EN 12426	-	Class 3
	Airborne sound insulation in compliance with DIN EN ISO 717-1	Only for EFA-THERM® lath	Rw = 24 dB
	Thermal insulation in compliance with DIN EN 12428	Only for EFA-THERM® lath for 4500 mm × 5200 mm	U = 1.60 W/m <sup>2</sup> K

npd = no performance determined

### 2.5 Fire performance

Fire performance as per DIN 4102

Indication	Value
Material class	B2 normally inflammable

## 2.6 Safety standards

### Applicable regulations, safety standards and directives

The following regulations, standards and directives were taken into account in planning, engineering and production:

#### Regulations

EUV 305/2011	REGULATION (EU) NO. 305/2011 OF THE EUROPEAN PARLIAMENT AND THE COUNCIL OF 9 March 2011 laying down harmonised conditions for the marketing of construction products and repealing Council Directive 89/106/EEC
--------------	---

#### Directives

2006/42/EC	DIRECTIVE 2006/42/EC OF THE EUROPEAN PARLIAMENT AND COUNCIL of 17 May 2006 on machinery, and amending Directive 95/16/EC
2014/30/EU	DIRECTIVE 2014/30/EU OF THE EUROPEAN PARLIAMENT AND COUNCIL of 26 February 2014 on harmonisation of the laws of the member states relating to electromagnetic compatibility
2014/53/EU	DIRECTIVE 2014/53/EU OF THE EUROPEAN PARLIAMENT AND OF THE COUNCIL of 16 April 2014 on the harmonisation of the laws of the Member States relating to the making available on the market of radio equipment and repealing Directive 1999/5/EC

#### Standards

DIN EN 13241	Doors – Product standard, performance characteristics
DIN EN ISO 13849-1	Safety of machinery – Safety-related parts of control systems – Part 1 General principles for design
DIN EN ISO 13849-2	Safety of machinery – Safety-related parts of control systems – Part 2 Validation
DIN EN ISO 12100	Safety of machinery – General principles for design – Risk assessment and risk reduction

## 2.7 Use

Door system type	Recommended frequency of use per year (up to)	Expected useful life <sup>1</sup>
307	400,000	20 years

<sup>1</sup> Includes 10 years German Product Liability Act

### 3 Construction of the high-speed spiral door

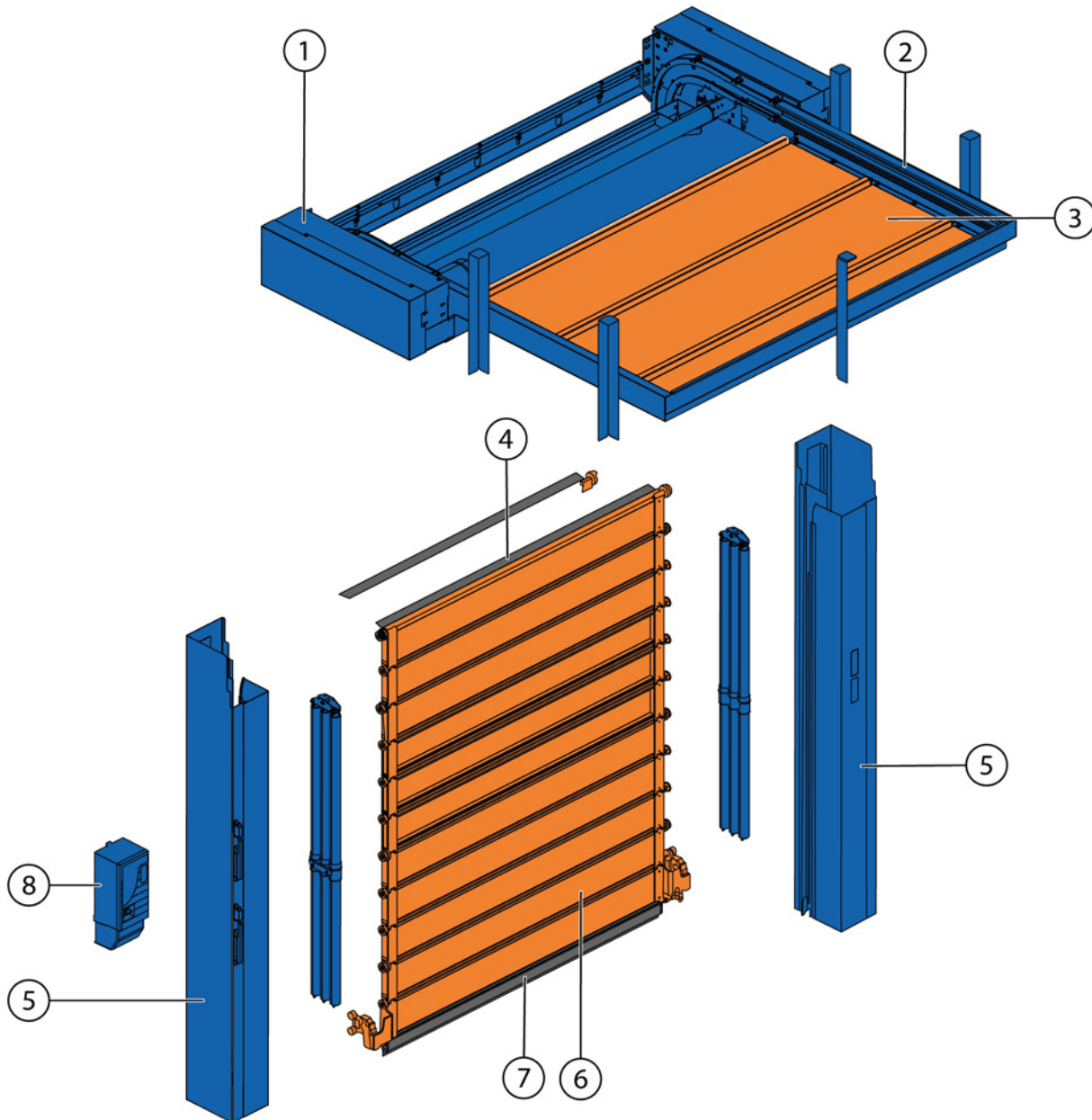

Fig. 4: Assemblies

1, 2	Low lintel spiral case (item 1) with main support, horizontal door leaf guide, drive, drive shafts, synchronous shaft, bearing, reinforcement profiles	<ul style="list-style-type: none"> <li>↳ "Spiral case versions" on page 12</li> <li>↳ Chapter 3.8 'Drives' on page 48</li> </ul>
3	Cover versions of the spiral case and horizontal guide	↳ Chapter 3.2 'Cover versions of the spiral case and horizontal guide' on page 13

## Construction of the high-speed spiral door

4	Horizontal seal	☞ <i>Chapter 3.7 'Seal' on page 47</i>
5	Side frames with vertical door leaf guide, weight counterbalance and door light grid	☞ <i>Chapter 3.4.4 'Door leaf guide' on page 26</i> ☞ <i>Chapter 3.3 'Transmission of force' on page 18</i> ☞ <i>Chapter 3.4.1 'Counterbalance' on page 19</i> ☞ <i>"Door light grid" on page 52</i>
6	Door leaf	☞ <i>'Door leaf with 40 mm thick EFA-THERM® laths' on page 36</i>
	Laths	☞ <i>"Overview of the laths for door system" starting on page 37</i>
7	Safety edge	☞ <i>Chapter 4.2 'Safety edge and light barrier' on page 53</i>
8	Control unit	☞ <i>Chapter 3.9 'Control units' on page 48</i>



*The high-speed spiral door has a symmetrical design. As a result, we always refer to an "operator side". The operator side has the controls such as the hand lever, EFA-HDI® etc.*

# Construction of the high-speed spiral door

Spiral case

## 3.1 Spiral case

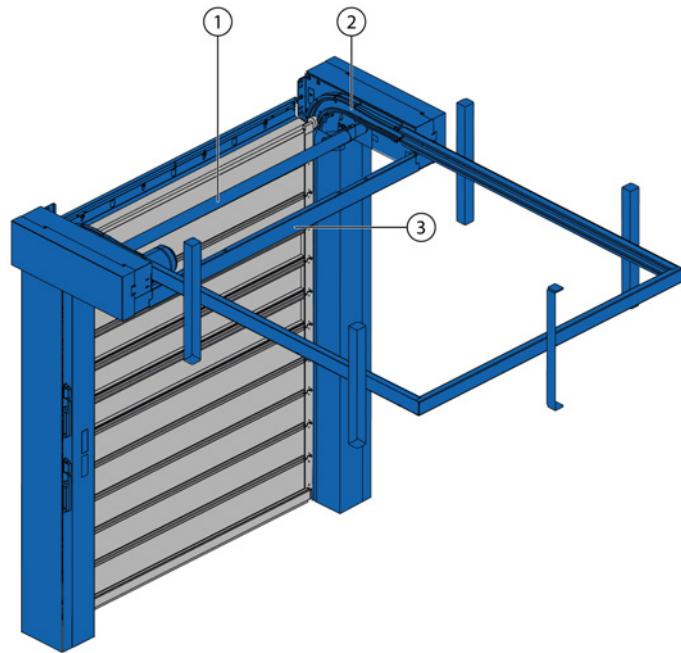

*Fig. 5: Spiral case*

The spiral case comprises:

- Synchronous shaft with bearing (item 1)
- Bevelled main supports with horizontal door leaf guide on both sides (item 2)
- Sheet metal reinforcement profiles (item 3)

Due to the optimised fixture of the main bearing, the entire unit (drive shaft with bearing) can be repaired or replaced quickly and easily. The mounting aid, on which the synchronous shaft with bearing can be set down for assembly purposes, makes this even easier.



*Protecting against falling is still required during installation.*

## Construction of the high-speed spiral door

Cover versions of the spiral case and horizontal guide

### 3.2 Cover versions of the spiral case and horizontal guide

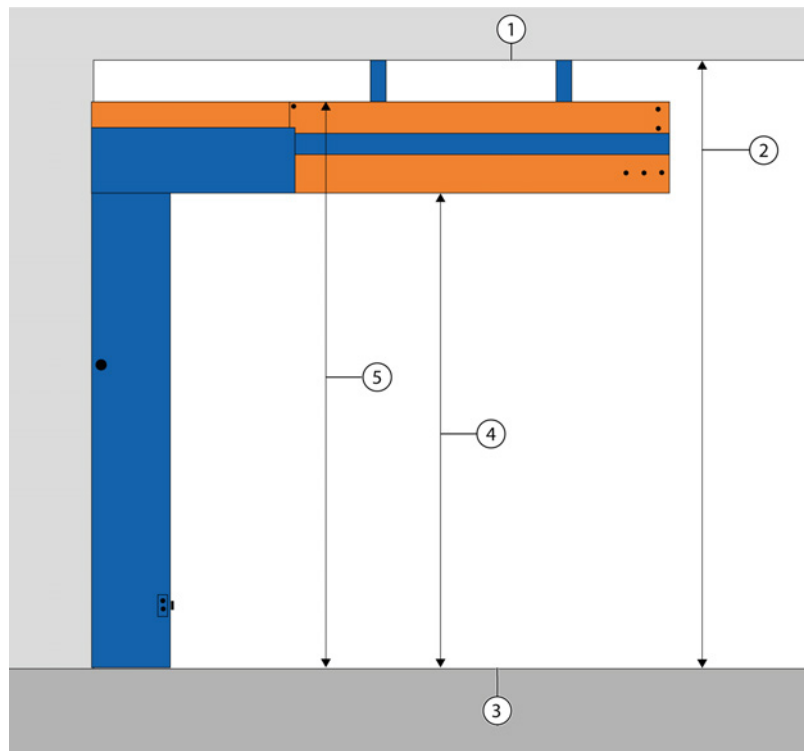

Fig. 6: Dimensioning, door system and ceiling

- 1 Ceiling
- 2 Ceiling height (DECKH)
- 3 Floor
- 4 Clear height (LH)
- 5 Installation height

To ensure the necessary access protection, different cover designs are required depending on the clear height (LH).

For a clear height (LH)  $\leq 2234$  mm, the ceiling height (DECKH) must be specified in SAP. For higher door systems, the DECKH does not have to be specified in SAP.

The installation height is displayed in the SAP configuration under "Internal" for a clear height (LH)  $< 2325$  mm.

The minimum and maximum ceiling height is calculated as follows:

- Min DECKH = LH + 335 mm
- Max DECKH = LH + 820 mm

## Construction of the high-speed spiral door

Cover versions of the spiral case and horizontal guide > Spiral case covers

### 3.2.1 Spiral case covers

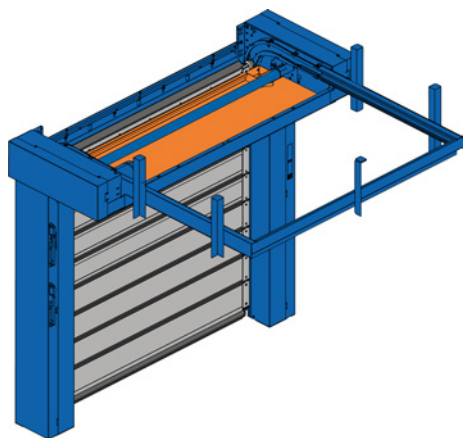

*The spiral case cover acts as a protective guard and is mandatory for a clear height (LH) < 2450 mm.*

*Fig. 7: Spiral case covers*

## Construction of the high-speed spiral door

Cover versions of the spiral case and horizontal guide > Securing the horizontal guide

### 3.2.2 Securing the horizontal guide

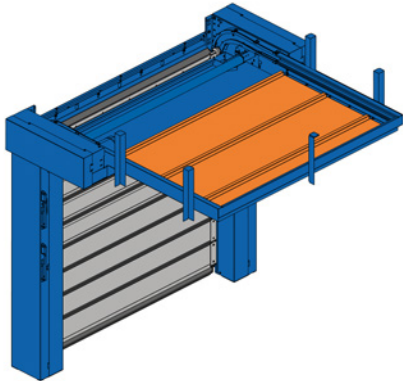

Fig. 8: Sheet metal protective guard (standard)

The sheet metal protective guard is supplied up to a LH  $\leq$  2449 mm as standard. From a LH  $\geq$  2450 mm, there is no need for a protective guard. The covers can be selected as an option. The own weight of the cover limits the area of application up to a LH  $\leq$  2700 mm. In addition, the laths version is used (see Fig. 9).

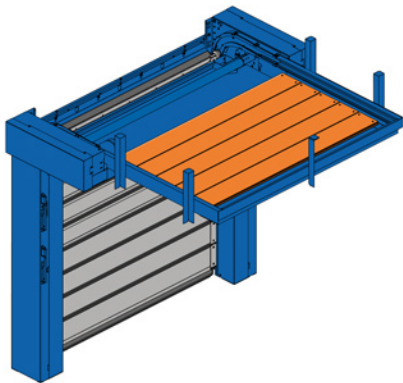

Fig. 9: Laths protective guard (optional)

The laths cover can be selected from a clear height LH  $\geq$  2325 mm and can be used up to the maximum height. The cover comprises EFA-THERM<sup>®</sup> laths (40 x 221 mm) and sheet metal mounts. This version is also installed if the sheet metal cover does not work due to its own weight (LH  $\geq$  2701 mm).

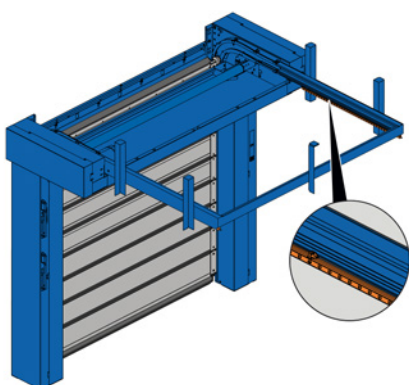

Fig. 10: Protective guard with door light grid (optional)

The use of a horizontally mounted light grid can be selected from a clear height (LH)  $\geq$  2325 mm. The design of the light grid limits the area of application to a LH  $\leq$  3597 mm.



The use of a door light grid reduces the speed (see Chapter 2.3 'Speeds' on page 8).

## Construction of the high-speed spiral door

Cover versions of the spiral case and horizontal guide > Height-dependent protective guard

### 3.2.3 Height-dependent protective guard

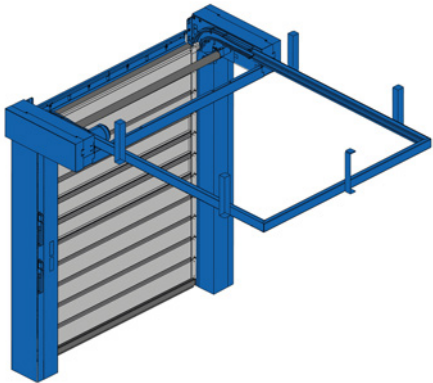

Fig. 11: No cover for  $LH \geq 2450$  mm

The spiral case covers are available in different versions, depending on the clear height. For a clear height ( $LH$ )  $\geq 2450$  mm, this door system type (307) does not require a cover to act as a protective guard.

The spiral case cover can still be selected as an option.

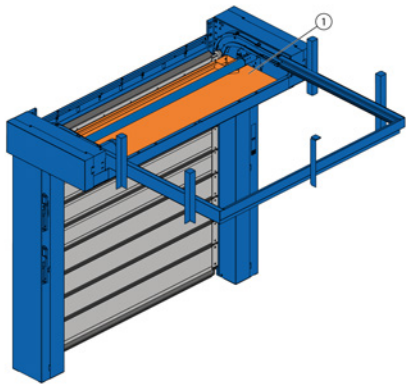

Fig. 12: Standard cover for  $2325 \text{ mm} \leq LH \leq 2449$  mm

1 Spiral case covers

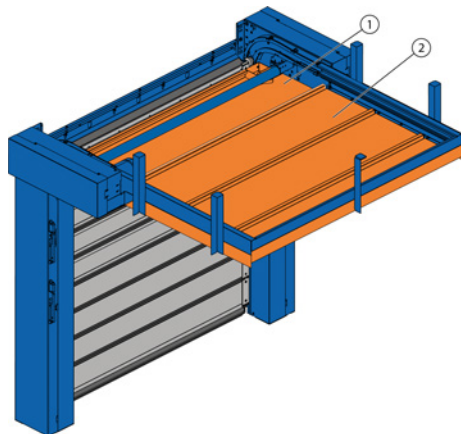
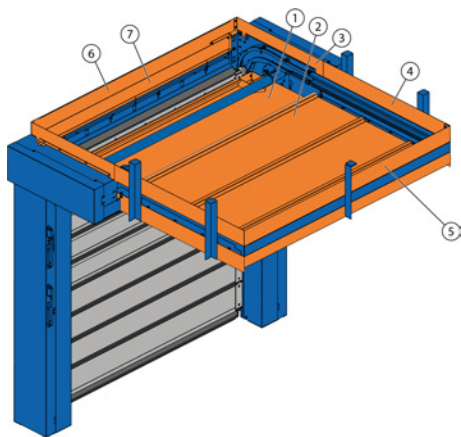

Fig. 13: Standard cover for  $2235 \text{ mm} \leq LH \leq 2324$  mm

1 Spiral case covers  
2 Horizontal guide cover

## Construction of the high-speed spiral door

Cover versions of the spiral case and horizontal guide > Height-dependent protective guard



- 1 Spiral case covers
- 2 Horizontal guide cover
- 3 Side console cover
- 4 Side top cover  $2205 \text{ mm} \leq LH \leq 2234 \text{ mm}$
- 5 Front top cover
- 6 Top lintel cover  $2205 \text{ mm} \leq LH \leq 2234 \text{ mm}$
- 7 Bottom lintel cover

*Fig. 14: Standard cover for  
 $1500 \text{ mm} \leq LH \leq 2234 \text{ mm}$*

## Construction of the high-speed spiral door

Side frames

### 3.3 Transmission of force

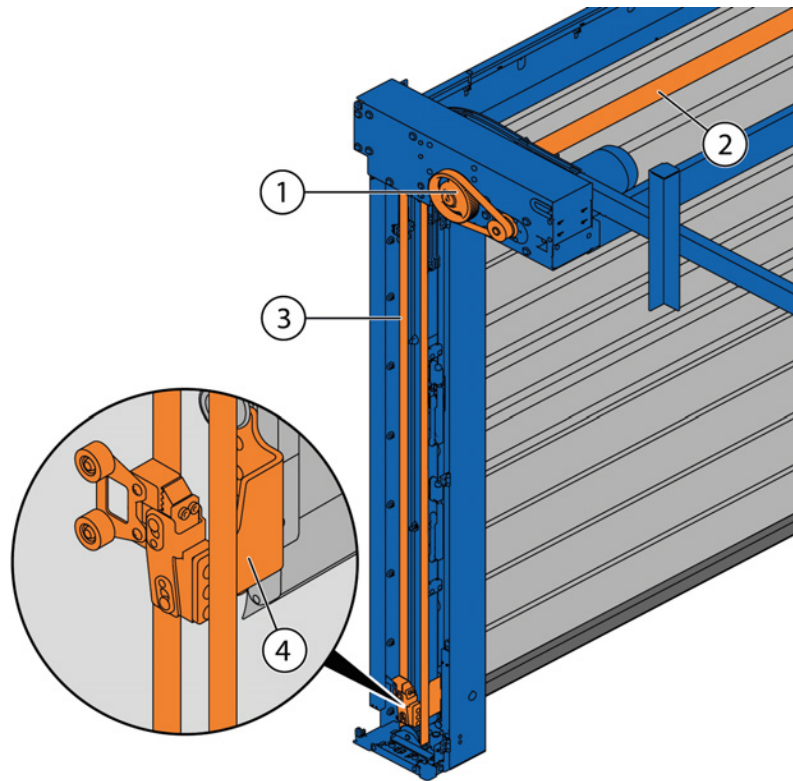

Fig. 15: Transmission of force

Force is transmitted from the drive to the door leaf by the drive chain (Fig. 15/1), synchronous shaft (Fig. 15/2), the continuous chains (Fig. 15/3) and the door leaf mounts (Fig. 15/4). Unlike a chain, the toothed belt runs very quietly.

The door leaf mounts are situated on the right and left-hand sides of the door leaf and are screwed to the hinge chains and the lowest lath of the door leaf (bottom lath). The hinge chains on both sides of the door system connect the bottom lath to the other laths. When the door leaf moves, the force is only applied to the bottom lath. All the other laths are fastened to the hinge chain and are moved at the same time without the effect of force.

### 3.4 Side frames

The side frames consist of the following components:

- Side frame: Bevelled sheet metal (steel or stainless steel)
- Side frame cover: Bevelled sheet metal (steel or stainless steel)
- Floor plate: Bevelled sheet metal (steel or stainless steel)
- Vertical guide: Bevelled sheet metal (steel or stainless steel) with screwed-on aluminium guide profiles

The shape of the side frame has been optimised to allow two different side frame cover designs.

### Designs

- Fixed
  - Special features: Classic, cost-optimised design
- Hinged with internal hinges
  - Special features: Excellent accessibility for maintenance and improved look due to internal hinges

### 3.4.1 Counterbalance

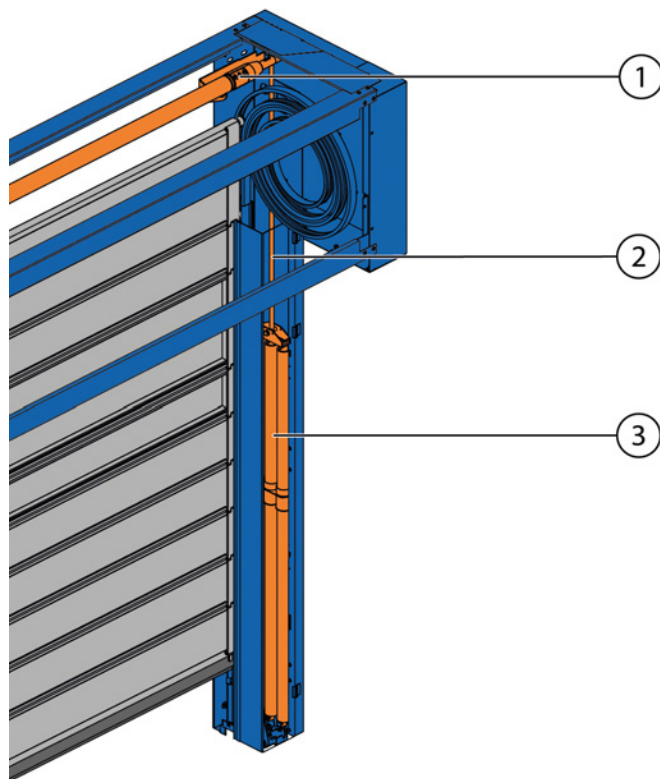

*Fig. 16: Counterbalance*

The door leaf is counterbalanced by a counter-pull mechanism: Tension springs (Fig. 16/3) are installed in the side frames (Fig. 16/2). The tension springs are connected to the synchronous shaft (Fig. 16/1) by heavy-duty belts. The tension springs are tensioned when the door system is closed and relaxed when the door system is open.

This enables the door system to be opened manually in case of a power failure. In normal mode the motor is assisted by the force of the tension springs.

The spring tension is calculated on an order-specific basis.

# Construction of the high-speed spiral door

Side frames > Manual release lever

## 3.4.2 Manual release lever



Fig. 17: Manual release lever on the side frame (left) and on a separate console (right)

The manual release lever is situated on the side frame or optionally on a separate console. When the lever is pulled, the drive brake is enabled and the door system is partially opened automatically by the tension springs of the weight counterbalance system. The door can be opened completely by pushing the door leaf upwards manually.

The manual release lever is also available in a lockable design (optional).

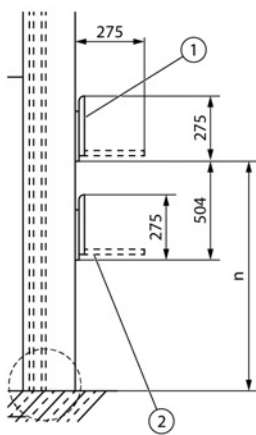

- 1 Manual release lever
- 2 Optional locking mechanism

n	Dimensions
1455 mm	2000 mm ≤ LH ≤ 5695 mm
LH - 545 mm	1500 mm ≤ LH ≤ 1999 mm

LH = Clear height

Fig. 18: Position of manual release lever

## 3.4.3 Door locking mechanism

### Manual door locking mechanism (optional)

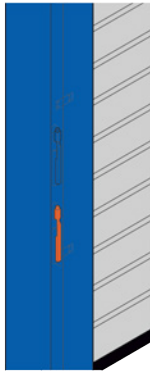

Fig. 19: Locking lever on side frame

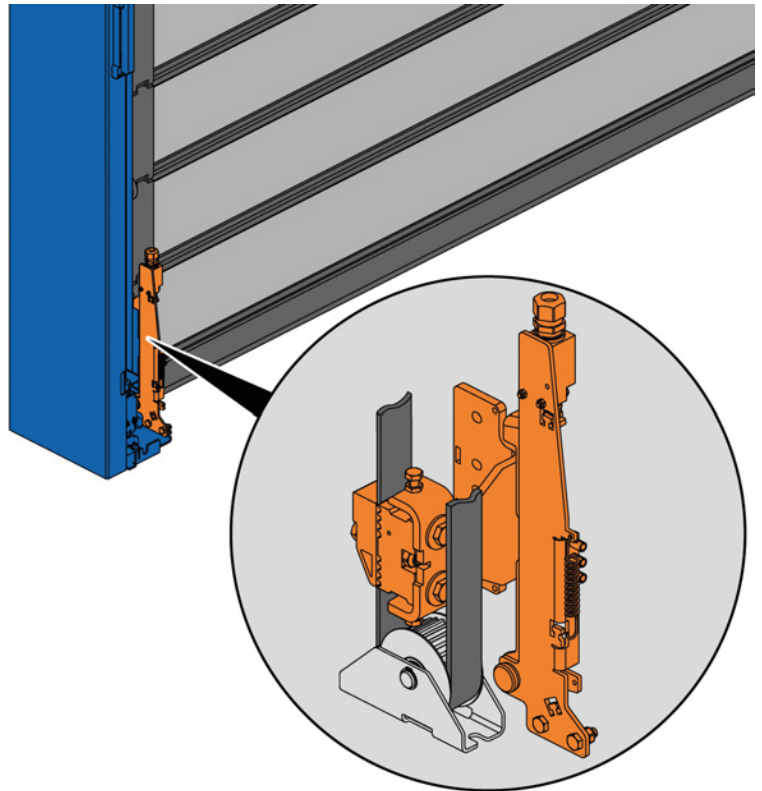

Fig. 20: Door locking mechanism in side frame

The mechanical locking mechanism is installed in the vertical side frame on the operator side. The locking mechanism handle keeps the door leaf closed so that it is safe from break-ins. The door locking mechanism is operated using a lever which is attached to the side frame or on an optional separate console.

## Construction of the high-speed spiral door

Side frames > Door locking mechanism

The following versions are possible:

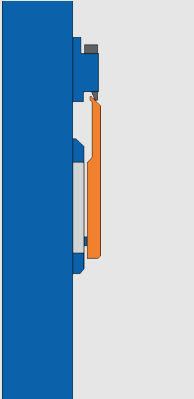
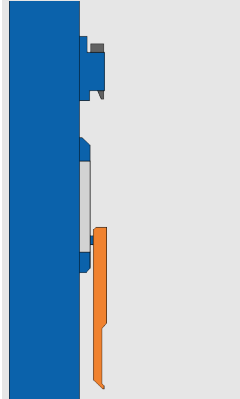
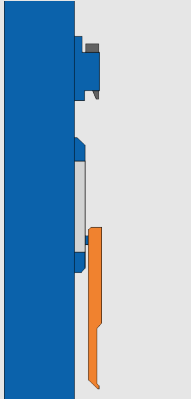
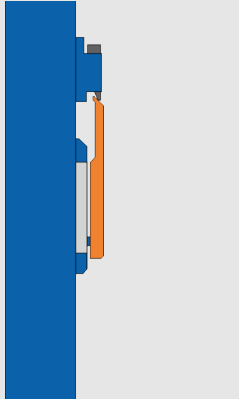
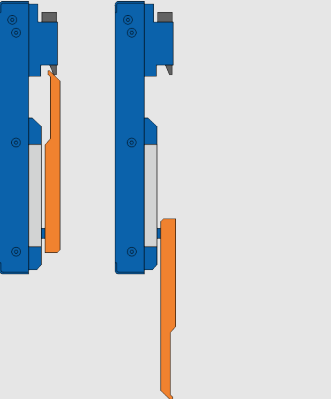
Standard version: Lever fitted to side frame		Optionally: Lever fitted to the side frame with reversed lever position		Optionally: Lever fitted to a separate console
Door leaf not locked	Door leaf locked	Door leaf not locked	Door leaf locked	
				
Lever position: Lever up	Lever position: Lever down	Lever position: Lever down	Lever position: Lever up	The lever position depends on laying of Bowden cable
Optional locking version			Optional locking version	Lever position up, optional locking version

### Automatic door locking mechanism (optional, only with EFA-TRONIC® Professional)

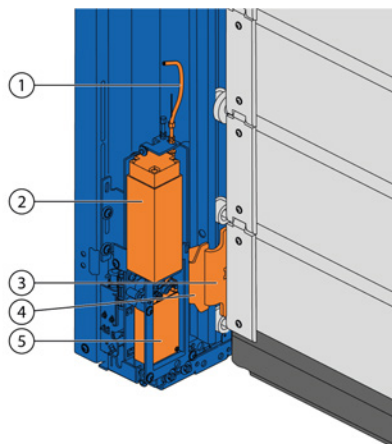

- 1 Bowden cable for emergency operation
- 2 Solenoid
- 3 Door leaf mount
- 4 Locking plate
- 5 Locking unit AV15 (AV18 and AV21 possible on request)

The automatic locking mechanism is installed in the vertical side frame on the operator side. A solenoid (Fig. 21/2) automatically moves the locking bolt into the counterpart (locking plate, Fig. 21/4 and Fig. 22/1) on the door leaf mount.

Activation:

- Automatic locking every time the door leaf reaches the lower end position.
- Locking by on-site signal.

Fig. 21: Automatic door locking mechanism

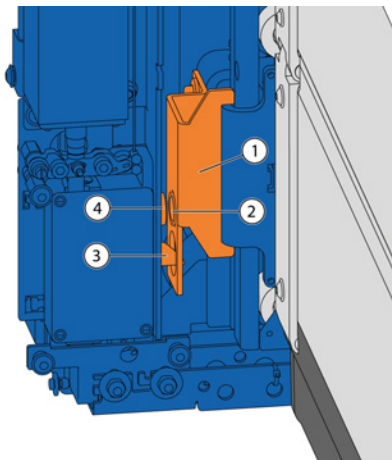

Fig. 22: Automatic door locking mechanism, permanent magnets

- 1 Locking plate
- 2 Permanent magnet on AV15 only
- 3 Locking bolt
- 4 Permanent magnet on AV15 only

### Version AV15, with accidental locking protection

The accidental locking protection system uses two permanent magnets, which are opposite one another with the same poles when the door is closed and repel one another (Fig. 22/2 and 4). The magnet installed in the accidental locking protection system (Fig. 22/4) is permanently connected to a locking piece, which can be moved in an axial direction. This forcibly mechanically releases the locking bolt (Fig. 22/3), the locking mechanism contact is closed and the door leaf is locked. When the door is not closed, the magnets are not opposite one another. The locking bolt is thus forcibly and securely locked. The locking mechanism contact is open. In case of a fault (power failure), the locking mechanism contact always remains in open position and cannot be accidentally locked when the door system is open.

### Version AV18 and AV21, without accidental locking protection system

The two permanent magnets are not fitted, which means that the locking bolt can be released in any door leaf position.

The AV18 and AV21 versions must be requested with a technical approval.

### Door leaf locking with bolt

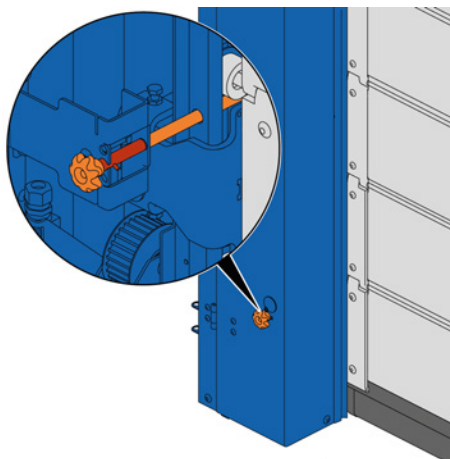

Fig. 23: Door leaf locking with bolt

Door leaf locking with bolt is used:

- Only for trained specialist personnel as additional security for maintenance/repairs
- Only as additional security when cleaning the door system

## Construction of the high-speed spiral door

Side frames > Door locking mechanism

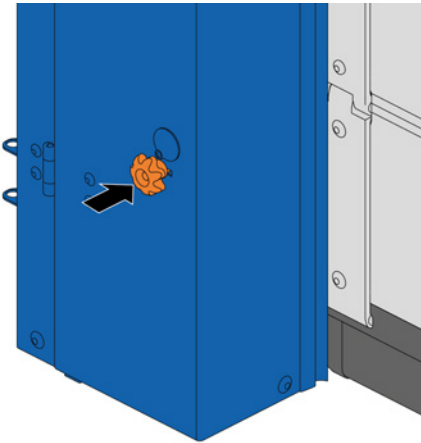

In the “Door closed” position, the bolt goes through the guide and thus blocks the rollers. When locked, the bolt is completely engaged in the side frame and the red part of the bolt is not visible.

*Fig. 24: Door leaf locking with bolt, locked*

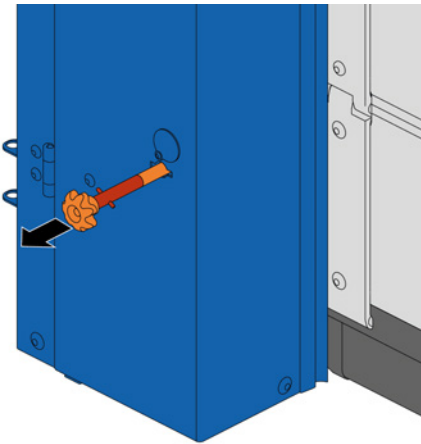

If the red part of the bolt is visible, the door leaf is not locked.

*Fig. 25: Door leaf locking with bolt, unlocked*

## Construction of the high-speed spiral door

Side frames > Door locking mechanism

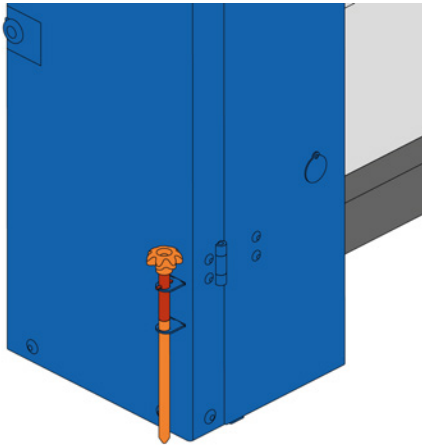

When the door system is being operated, the bolt is inserted into the side frame.

The opening for the bolt in the side frame cover is then closed using the rotating sheet metal cover.

*Fig. 26: Door leaf locking with bolt, on side frame*

## Construction of the high-speed spiral door

Side frames > Door leaf guide

### 3.4.4 Door leaf guide

Door leaf guide, side frame and side frame cover

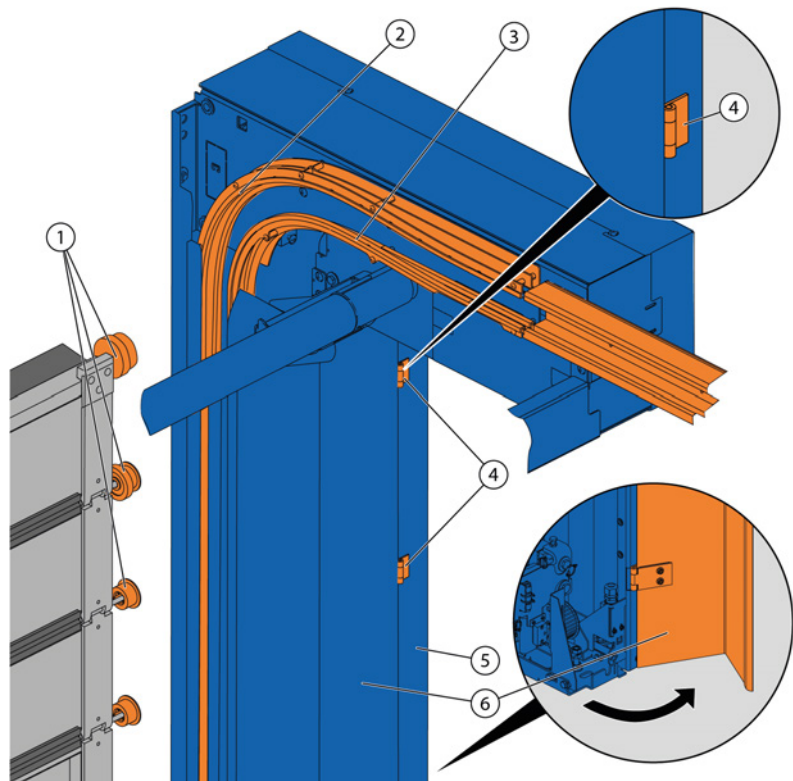

Fig. 27: Door leaf guide

The door leaf comprises laths which are connected by a hinge chain. Rollers (Fig. 27/1) are attached to the hinge chain, which are directed through the door leaf guide (Fig. 27/3) when the door system is opened and closed. Very little noise is generated by the rolling of the rollers in the door leaf guide. The roller friction also ensures minimum wear on the rollers as no soiling is generated from abrasion. There is no wear on the door leaf itself. This gives the door system a long service life.

The vertical door leaf guides (Fig. 27/2) are made of sheet metal and aluminium profiles and are situated within the side frames (Fig. 27/5). Each side frame is made up of one main bevelled sheet metal profile and one bevelled sheet metal cover profile (Fig. 27/6). The side frame covers pivot-mounted using hinges (Fig. 27/4). Optionally, the sheet metal cover profiles can be attached with screws.

For more information about this door-specific design option, see [Chapter 3.1 'Spiral case' on page 12.](#)

## 3.4.5 Side frame extension

The side frame extensions have the same construction as the side frames. In SAP, it is possible to freely configure whether one or two side frame extensions are required (depending on the installation situation). The type of side frame extension depends on the application or the design of the closing strip extension.



*If "Stainless steel floor plate" is selected, only the lower floor plate of the side frame extension, which is also on the floor, is made of stainless steel. The floor plate of the side frame is made of galvanised sheet metal.*

Use	Shim plates	Side frame extension closed, Fig. 28	Side frame extension open, Fig. 29	Side frame extension with guide, Fig. 29
Compensation for floor level	≥ 2 mm to < 70 mm	≥ 70 mm	-	-
Flexible closing strip extension	≥ 2 mm to < 70 mm	≥ 70 mm	-	-
Rigid closing strip extension	≥ 2 mm to < 70 mm	-	≥ 70 mm	≥ 110 mm

- Not possible

- The left and right side frame extensions can be selected independently in SAP in the range from 2 mm to 2500 mm.
- With the flexible closing strip extension the length of the side frame extension can be selected independently of the length of the closing strip extension.
- With the rigid closing strip extension the length of the side frame extension must be the same as or greater than the height of the closing strip extension.



*The clear height (LH) is always reduced by at least 390 mm due to the door closing strip extensions. The reason for this is that the "Door open" position must be mechanically blocked so that the door closing strip does not retract into the 90° spiral guide (see Chapter 3.4.4 'Door leaf guide' on page 26) and thus perform a rotational movement. Flexible or rigid extensions must also be taken into account.*

## Construction of the high-speed spiral door

Side frames > Flexible closing strip extension

### Side frame extension closed

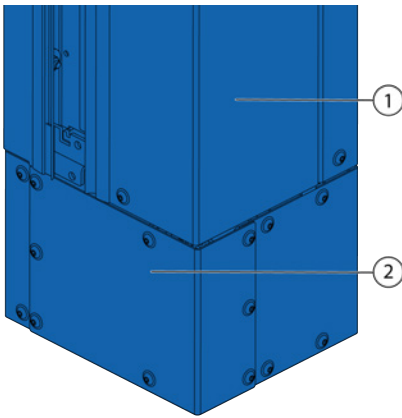

- 1 Side frame
- 2 Side frame extension without guide / closed

*Fig. 28: Side frame extension closed*

### Side frame extension open

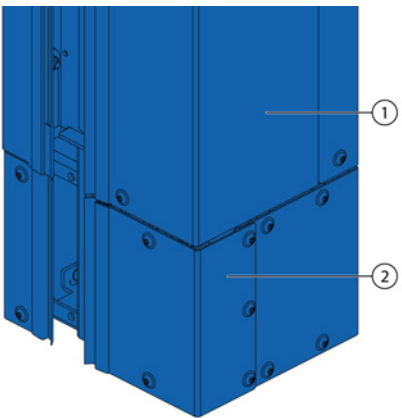

- 1 Side frame
- 2 Side frame extension with guide / open

*Fig. 29: Side frame extension open*

### 3.4.6 Flexible closing strip extension

If the floor is uneven, slanted or lower than the installation level of the side frames, the lower closing strip can be extended. This is done using a flexible PES fabric, which is pre-fitted on the lower closing strip based on the SAP configuration specifications.

## Construction of the high-speed spiral door

Side frames > Flexible closing strip extension

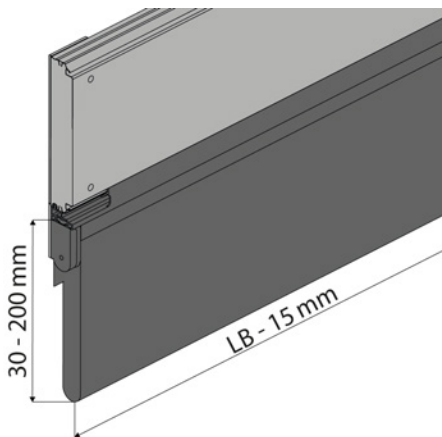

This design is possible with or without a side frame extension (without guide / closed). The flexible side frame extension is always narrower than the clear width (LB) – 15 mm.

*Fig. 30: Flexible closing strip extension – straight*

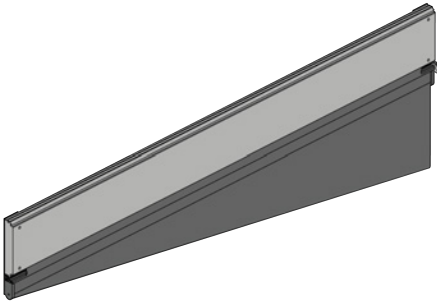

*Fig. 31: Flexible closing strip extension – slanted*

### Possible flexible extension design for Door system type 307

Length	30 mm – 200 mm
Material	PES fabric (0.8 mm thick material, polyester fabric coated with PVC), smooth on both sides, black
Shape	Straight extension Slanted extension to left or right
Safety	Secured by door light grid and safety edge
Restrictions	All performance features apart from "Resistance to wind load" are specified as "npd"

## Construction of the high-speed spiral door

Side frames > Rigid closing strip extension

### 3.4.7 Rigid closing strip extension

If the floor is slanted or lower than the installation level of the side frames, the lower closing strip can be extended.

This design is only possible with a side frame extension.

A design without side frame extension must be requested with a technical approval.

The basis for the closing strip extension is a double-walled EFA-CLEAR® lath with aluminium sheet filling.

At a length of  $\geq 110$  mm additional rollers are attached to the sides to minimise the load on the mechanical assembly. As a result there are no restrictions in the "Resistance to wind load".

#### Possible rigid extension design for Door system type 307

Length	30 mm – 400 mm	
	$\geq 2$ mm to < 70 mm	Shim plates are supplied.
	$\geq 70$ mm	A side frame extension with guide / open is required. This is because the extension is always wider than the clear width. This means that in "Door closed" position there is no gap between the lower closing strip and the side frame extension.
Material	EFA-CLEAR® double-walled lath with aluminium sheet filling. The aluminium sheets used in the thermally separated profiles (adhesive connection) are straight or slanted depending on the SAP configuration. This produces the required shape.	
Finish	E6/EV1, optional wet coating as per RAL according to SAP	
Shape	Straight extension	
	Slanted extension to left or right	
Safety	Secured by door light grid and safety edge	
Restrictions	All performance features apart from "Resistance to wind load" are specified as "npd"	

## Straight design

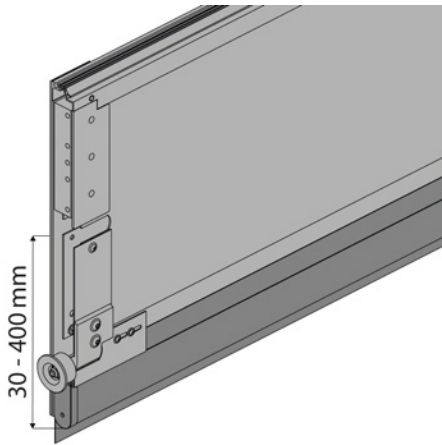

A straight extension can compensate for a difference of 30 mm – 400 mm.

Fig. 32: Straight design

## Slanted extension

A slanted extension can compensate for a difference of 30 mm – 400 mm. The left and right side can be configured independently in SAP.

## 3.4.8 End positions

The following limit switches can be integrated into the door system:

- Inductive sensor – Pepperl & Fuchs NJ15, see ↗ page 31
- Transponder-coded safety limit switch – Euchner CES, see ↗ page 32
- Roller lever limit switch – Schmersal ZV7H, ↗ page 33

Note that simultaneous selection of limit switches and EFA-SCAN® is not possible due to space restrictions.

### Inductive sensor – Pepperl & Fuchs NJ15

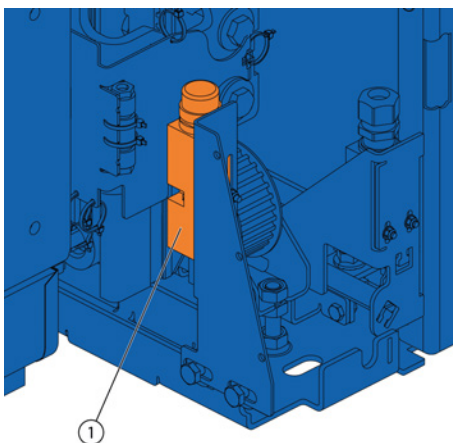

Fig. 33: “Door closed” inductive sensor

Application	“Door closed” and/or “Door open” message
Default	Customer/owner
Evaluation	Customer/owner
Safety category	none
Special feature	none

## Construction of the high-speed spiral door

Side frames > End positions

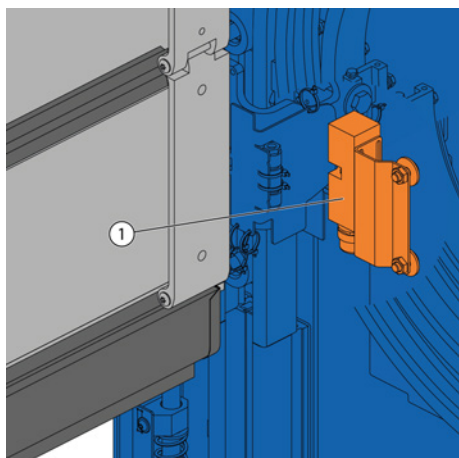

Fig. 34: "Door open" inductive sensor

### Transponder-coded safety limit switch – Euchner CES

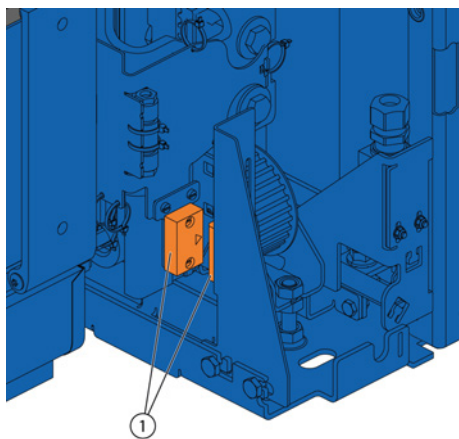

Fig. 35: "Door closed" transponder-coded safety limit switch

Application	"Door closed" and/or "Door open" safe message
Default	Customer/owner
Evaluation	Customer/owner
Safety category	Cat. 4/PL "e" (category, performance level) according to DIN EN ISO 13849-1
Special feature	<p>Applicable for EFA-TRONIC® Professional</p> <ul style="list-style-type: none"> <li>■ Analysis device is integrated in the control unit</li> </ul> <p>Applicable for EFA-TRONIC®</p> <ul style="list-style-type: none"> <li>■ Analysis device is supplied separately</li> </ul>

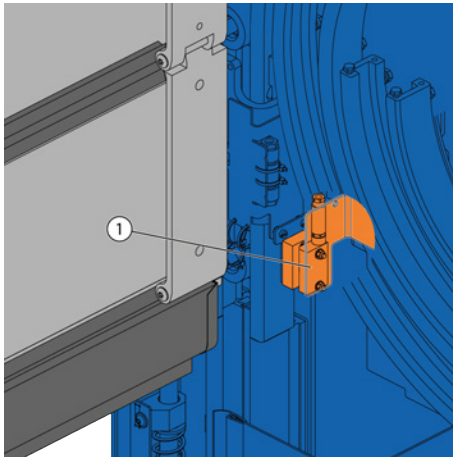

Fig. 36: "Door open" transponder-coded safety limit switch

### Roller lever limit switch – Schmersal ZV7H

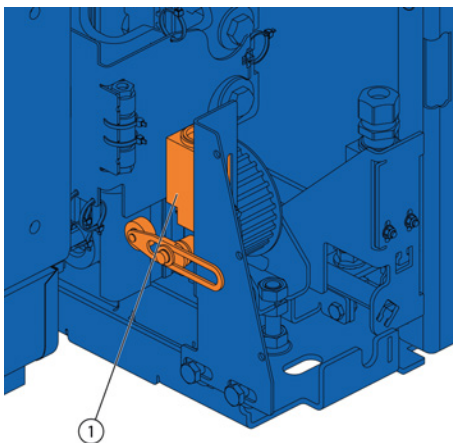

Fig. 37: "Door closed" roller lever limit switch

Application	"Door closed" and/or "Door open" message
Default	Customer/owner
Evaluation	Customer/owner
Safety category	none
Special feature	The status message can be detected without voltage.

## Construction of the high-speed spiral door

Resistance class

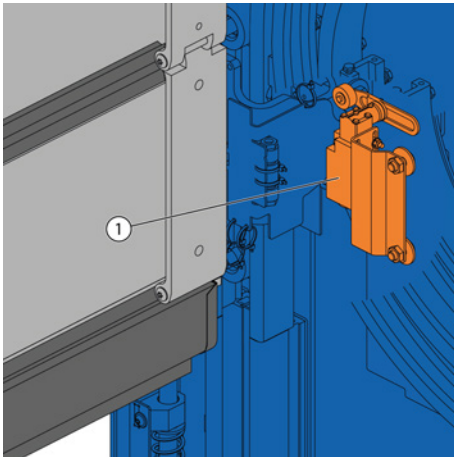

Fig. 38: "Door open" roller lever limit switch

### 3.4.9 Spring or belt break detector

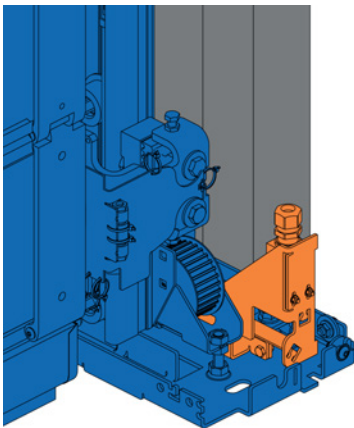

Fig. 39: Spring or belt break detector

The spring or belt break detector (Fig. 39) is integrated into the left and right side frame and increases the safety of the door system. It detects a break in the spring or belt and reports this to the control unit.

## 3.5 Resistance class

**Resistance class 2 (RC2) as defined in DIN V ENV 1627:1999-04 and (RC2) as defined in DIN/TS 18194:2020**

Resistance class 2 is achieved after each complete closure to the "Door closed" position and subsequent locking of the door leaf (see [Chapter 3.4.3 'Door locking mechanism'](#) on page 21).

Resistance class 2 means that an opportunist with simple tools such as screwdrivers, pliers and wedges cannot break (open or penetrate) the door system within three minutes.

**The following equipment is applicable for the 307:**

- EFA-THERM<sup>®</sup> lath with 0.4 mm steel plate ( [see 'Structure of the EFA-THERM<sup>®</sup> lath'](#) on page 37)
- Emergency operation device on side frame, lockable
- Locking mechanism on side frame or automatic locking mechanism
- No single-walled EFA-CLEAR<sup>®</sup> transparent laths
- No EFA-VENT<sup>®</sup> ventilation laths

- One double-walled EFA-CLEAR® transparent lath with SAN filling
- Combination of:
  - One EFA-THERM® lath
  - One double-walled EFA-CLEAR® transparent lath with SAN fillingTwo double-walled EFA-CLEAR® transparent laths with SAN filling must not be positioned directly above one another. There must be at least one EFA-THERM® lath in between.
- Combination of:
  - Maximum four double-walled EFA-CLEAR® transparent laths with hard polycarbonate filling
  - One EFA-THERM® lath
  - Maximum four double-walled EFA-CLEAR® transparent laths with hard polycarbonate fillingNo more than four double-walled EFA-CLEAR® transparent laths with hard polycarbonate filling are to be positioned directly above one another. There must be at least one EFA-THERM® lath in between.

In general:

- The use of a side frame extension must be examined on a case-by-case basis.
- The use of screw-through assembly must be examined on a case-by-case basis.

The door system type is listed in what is known as the “KPK list” (KPK: Kommission Polizeiliche Kriminalprävention; Commission for Crime Prevention), which can be accessed online via the Bavarian State Criminal Police Office. This KPK list records tested and certified burglar-resistant products and is updated twice a year as scheduled.



Fig. 40: Seal manufacturer directories

## Construction of the high-speed spiral door

Door leaf, laths and door leaf design

### 3.6 Door leaf, laths and door leaf design

Door leaf with 40 mm thick  
EFA-THERM® laths

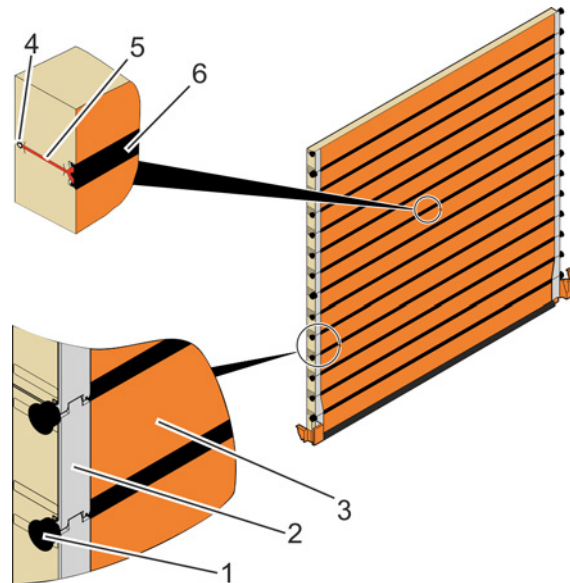

Fig. 41: Door leaf with 40 mm thick EFA-THERM® laths and a spacing of 225 mm

Door system type	Thickness of the door leaf
307	40 mm

The door leaf is assembled from laths (Fig. 41/3) which are kept at the correct spacing by hinge chains (Fig. 41/2) attached at the sides. This spacing prevents contact between the laths. They are thus free from wear. The forces for opening and closing the door system are transmitted via hinges.

Ball-bearing mounted rollers (Fig. 41/1) keep the door leaf firmly in the guides in the horizontal direction. The laths are connected to one another by rubber hinges (Fig. 41/6) and O-profile seals (Fig. 41/4). An air cushion (Fig. 41/5) is created between. It provides similarly effective insulation as that of the laths.

This homogeneous door leaf construction ensures the very good running performance, the high running speed and the excellent U-value.

## Construction of the high-speed spiral door

Door leaf, laths and door leaf design

### Structure of the EFA-THERM® lath

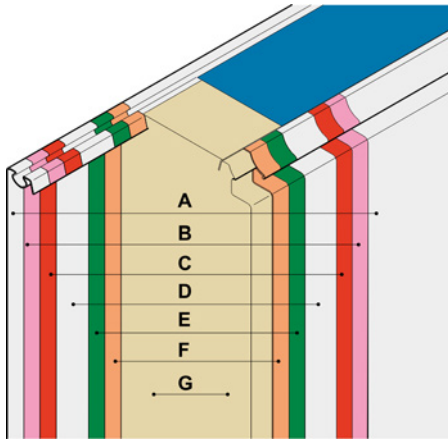

The EFA-THERM® laths are structured with the following layers:

- A Top coat
- B Primer
- C Zinc layer 150 g/m<sup>2</sup>
- D Sheet metal (made of steel coil)
- E Zinc layer 150 g/m<sup>2</sup>
- F Adhesive
- G PU hard foam, 42 kg/m<sup>3</sup>, CFC and HCFC free

Fig. 42: Structure of the EFA-THERM® lath

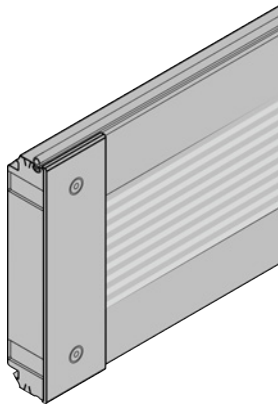

Fig. 43: EFA-THERM® lath with lining

Dimensions	40 × 222 mm
Material	Steel plate 0.4 mm
Finish	2 coats of paint
Colour	White aluminium, similar to RAL 9006 or grey aluminium, similar to RAL 9007
Optional	Wet lath coating Colours in compliance with SAP

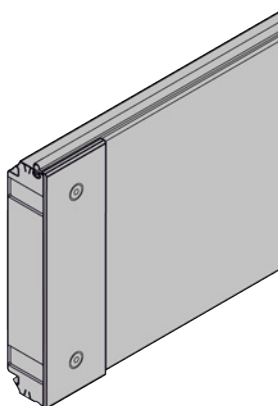

Fig. 44: EFA-THERM® lath without lining, smooth finish

Dimensions	40 × 222 mm
Material	Steel plate 0.4 mm
Finish	2 coats of paint
Colour	White aluminium, similar to RAL 9006 or grey aluminium, similar to RAL 9007
Optional	Wet lath coating Colours in compliance with SAP

## Construction of the high-speed spiral door

Door leaf, laths and door leaf design

### Closing strip

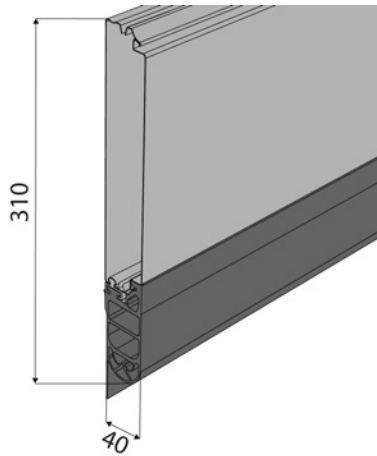

Construction	EFA-THERM® lath with adapter profile and rubber closing strip (floor seal)
Dimensions	40 × 310 mm
Adapter profile material/finish	Plastic/black, not coated

Fig. 45: Closing strip

### Door system type 307

Sheet thickness	Material	Surface/colour		With or without lining
		Coil colour	RAL wet coating	
0.4 mm	Steel	9006	-	Available
0.4 mm	Steel	9007	-	Available
0.4 mm	Steel	-	As per SAP	Available

## Construction of the high-speed spiral door

Door leaf, laths and door leaf design

### EFA-CLEAR® transparent lath, double-walled (optional)

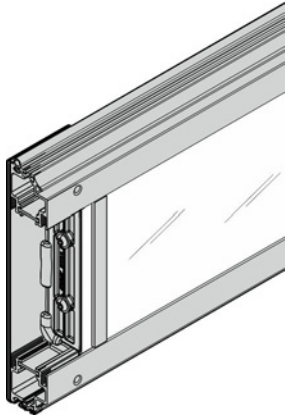

Fig. 46: EFA-CLEAR® transparent lath, double-walled

The EFA-CLEAR® double-walled, thermally insulated transparent laths are each comprised of two plastic panes which are pressed into aluminium profiles with spacing between the panes.

Dimensions	40 × 222 mm Viewing area height: Approx. 135 mm
Finish	E6/EV1 (natural anodised)
Glazing	SAN pane (transparent) Hard polycarbonate panes (scratch resistant, transparent) One SAN pane with frosted glass finish (opal) with 75% translucency, on outside of door leaf One transparent SAN pane on inside of door leaf
Optional	Wet coating for aluminium profiles Colours in compliance with SAP

The number of EFA-CLEAR® transparent laths is limited.

### EFA-CLEAR® transparent lath, single-walled (optional)

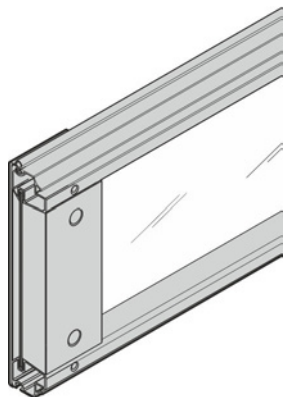

Fig. 47: EFA-CLEAR® transparent lath (single-walled)

The EFA-CLEAR® transparent laths comprise transparent plastic panes pressed into aluminium profiles.

Dimensions	40 × 222 mm Viewing area height: Approx. 155 mm
Finish	E6/EV1 (natural anodised)
Glazing	SAN panes (transparent) Hard polycarbonate panes (scratch resistant, transparent) SAN panes with frosted glass finish (opal) and 75% translucency
Optional	Wet coating for aluminium profiles Colours in compliance with SAP

The number of EFA-CLEAR® transparent laths is not limited.

## Construction of the high-speed spiral door

Door leaf, laths and door leaf design

### EFA-VENT® ventilation lath (optional)

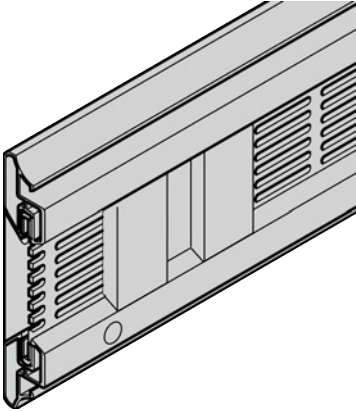

Fig. 48: EFA-VENT® ventilation lath

The EFA-VENT® ventilation laths comprise aluminium sheets with elongated holes (50 × 6 mm), which are pressed into aluminium profiles.

Dimensions	40 × 222 mm
Finish	Anodised E6/EV1
Vent cross-section (LA) in m <sup>2</sup>	LA = ((LB-0.105) × 0.066) × number of laths LB = Clear width in metres
Optional	Wet coating of aluminium profiles and ventilation laths Colours in compliance with SAP

The number of EFA-VENT® ventilation laths is not limited.

### LA1

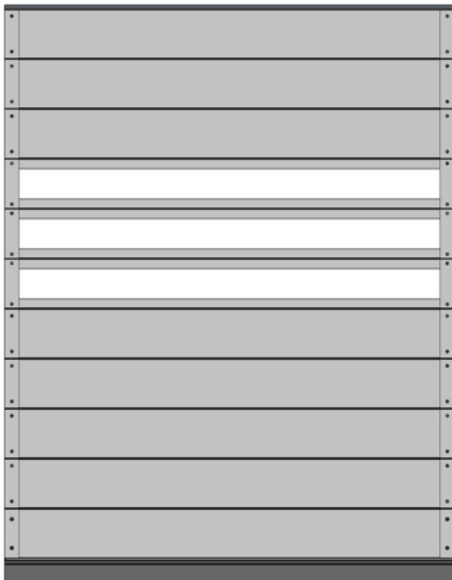
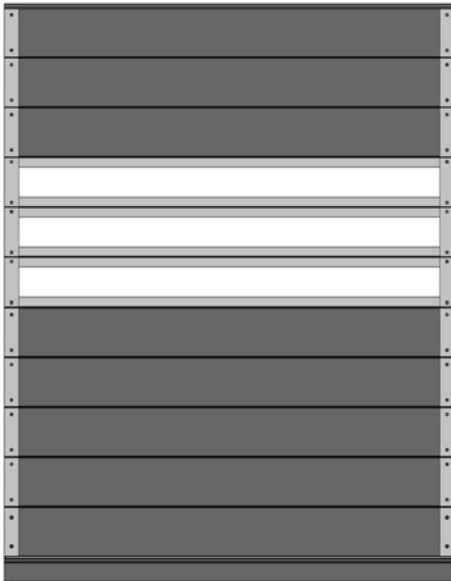

Fig. 49: Door leaf design LA1

View from the outside

- EFA-THERM® lath, steel sheet, surface similar to RAL 9006
- EFA-THERM® lath protective sheet (aluminium), surface E6/EV1 (natural anodised) and screws galvanised/stainless steel
- EFA-CLEAR® lath, single or double glazing or ventilation lath (aluminium), surface E6/EV1 (natural anodised) and screws galvanised/stainless steel

## LA2



### Exterior view

- EFA-THERM® lath steel sheet, surface similar to RAL 9007
- EFA-THERM® lath protection sheet metal (aluminium), surface E6/EV1 (naturally anodised) and galvanised screws/stainless steel
- EFA-CLEAR® lath single or double glazing or ventilation lath (aluminium), surface E6/EV1 (naturally anodised) and galvanised screws/stainless steel

Fig. 50: Door leaf version LA2

## LA3

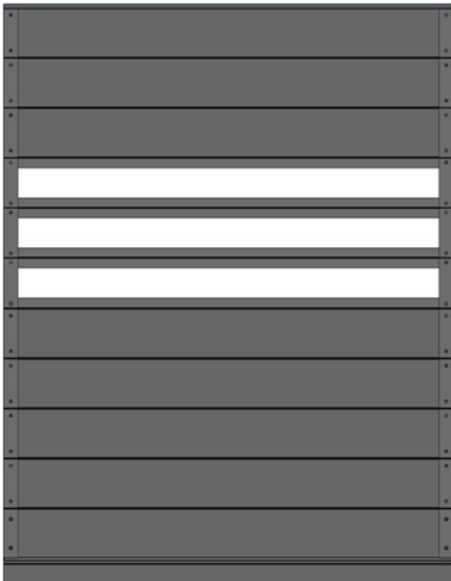

### Exterior view

- EFA-THERM® lath steel sheet, surface similar to RAL 9007
- EFA-THERM® lath protection sheet metal (aluminium), and screws with wet paint similar to RAL 9007
- EFA-CLEAR® lath single or double glazing or ventilation lath (aluminium) with wet paint similar to RAL 9007

Fig. 51: Door leaf version LA3

## Construction of the high-speed spiral door

Door leaf, laths and door leaf design

### LA4



#### Exterior view

- EFA-THERM® lath steel sheet, surface similar to RAL 9007
- EFA-THERM® lath protection sheet metal (aluminium), and screws with wet paint similar to RAL 9007
- EFA-CLEAR® lath single or double glazing or ventilation lath (aluminium), surface E6/EV1 (naturally anodised) and galvanised screws/stainless steel

Fig. 52: Door leaf version LA4

### LA1 (interior)

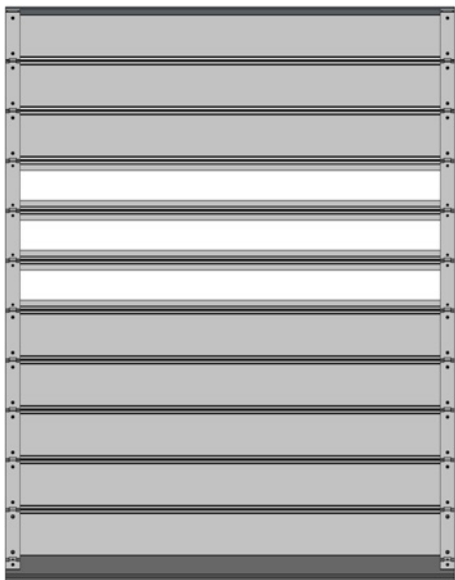

#### Interior view

- EFA-THERM® lath steel/aluminium sheet, surface similar to RAL 9006
- Hinge chain (aluminium), surface E6/EV1 (naturally anodised) and galvanised screws/stainless steel
- EFA-CLEAR® lath single or double glazing or ventilation lath (aluminium), surface E6/EV1 (naturally anodised) and galvanised screws/stainless steel

Fig. 53: Door leaf version LA1 interior

### LA2 and LA4 (interior)

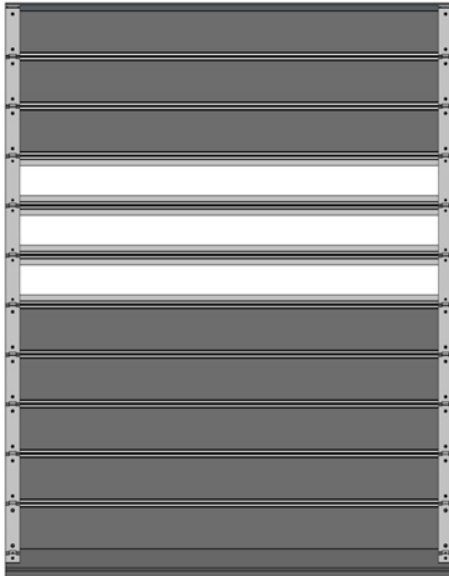

#### Interior view

- EFA-THERM® lath steel/aluminium sheet, surface similar to RAL 9007
- Hinge chain (aluminium), surface E6/EV1 (naturally anodised) and galvanised screws/stainless steel
- EFA-CLEAR® lath single or double glazing or ventilation lath (aluminium), surface E6/EV1 (naturally anodised) and galvanised screws/stainless steel

Fig. 54: Door leaf version LA2 and LA4 interior

### LA3 (interior)

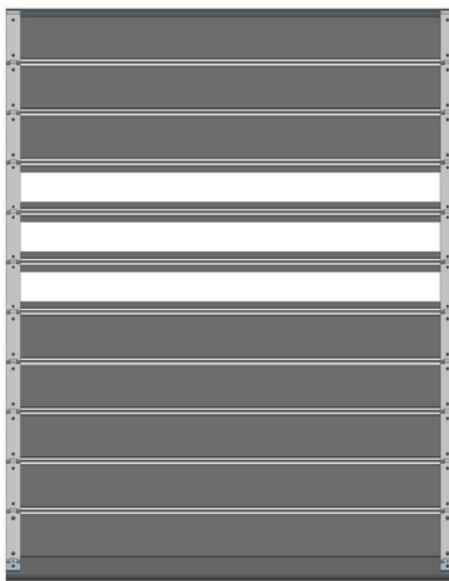

#### Interior view

- EFA-THERM® lath steel/aluminium sheet, surface similar to RAL 9007
- Hinge chain (aluminium), surface E6/EV1 (naturally anodised) and galvanised screws/stainless steel
- EFA-CLEAR® lath single or double glazing or ventilation lath (aluminium) with wet paint similar to RAL 9007

Fig. 55: Door leaf version LA3 interior

### 3.6.1 Corrosion protection

Regardless of equipment, the entire door system meets the requirements of corrosion protection class C3m as defined in DIN EN ISO 12944-6:2018. However, looking at the side frames and spiral cases and the door leaf individually results in different corrosion protection specifications.

## Construction of the high-speed spiral door

Door leaf, laths and door leaf design > Corrosion protection

### Entire door system

Corrosion protection in accordance with DIN EN ISO 12944-6:2018 C3m

### Side frames and spiral case

Frame surface	Z1, steel galvanised	Z4 Powder coating	Z6, stainless steel V2A
Design	Steel, galvanised (275 g/m <sup>2</sup> , approx. 20 µm zinc coat thickness)	Steel, galvanised (275 g/m <sup>2</sup> , approx. 20 µm zinc coat thickness) with one-sided polyester based powder coating on surface visible from outside as per RAL according to SAP (decorative surface coating).  Coat thickness approx. 50 µm +/- 10 µm  Sheen level in compliance with DIN EN ISO 2813 (incidence angle 60°), 75 % ± 10 %  Connecting components galvanised, not coated.	V2A stainless steel, corrosion resistant; polished grain 220, V2A connecting components.
Special features	Sheet thicknesses <ul style="list-style-type: none"> <li>■ ≤ 4 mm: sendzimir galvanised</li> <li>■ &gt; 4 mm: electrogalvanised</li> </ul>	Sheet thicknesses <ul style="list-style-type: none"> <li>■ ≤ 4 mm: sendzimir galvanised</li> <li>■ &gt; 4 mm: electrogalvanised</li> </ul>	The tension springs (bright steel, oiled), the door leaf toothed belts (galvanised tension members) and various small parts cannot be made of V2A.
Corrosion protection class in accordance with DIN EN ISO 12944-6:2018, special features: Tension springs and door leaf toothed belts	C3m	C3m	C3m
Corrosion protection class in accordance with DIN EN ISO 12944-6:2018, for general steel parts / internal parts	C3m	C3m	C3m

## Construction of the high-speed spiral door

Door leaf, laths and door leaf design > Corrosion protection

Frame surface	Z1, steel galvanised	Z4 Powder coating	Z6, stainless steel V2A
Corrosion protection class in accordance with DIN EN ISO 12944-6:2018, for externally visible steel parts	C3m	C3m	C5-I
Use	"Normal" industrial door	"Normal" industrial door	Industrial door in areas with high humidity and aggressive atmosphere. No "washing systems".

### Door leaf

Lath finish	LA1, LA2, and LA4	LAS
Design	EFA-THERM® laths	EFA-THERM® laths with additional polyurethane based wet coating of the visible surface as per RAL according to SAP (decorative surface coating).  Coat thickness approx. 50 µm +/- 10 µm  Sheen level in compliance with DIN EN ISO 2813 (incidence angle 60°), 30 % ± 10 %  Connecting components galvanised, not coated.
Special features	-	Corrosion protection class as per DIN EN ISO 12944-6:2018 is only valid for steel components, therefore is not applicable for EFA-CLEAR® or EFA-VENT® aluminium laths.
Door leaf corrosion protection class as per DIN EN ISO 12944-6:2018	C3m	C4m
Use	"Normal" industrial door	Industrial door in areas with high humidity and aggressive atmosphere. No "washing systems".

## Construction of the high-speed spiral door

Door leaf, laths and door leaf design > Corrosion protection

### DIN EN ISO 12944

Corrosivity category	Area of application		Note (EFAFLEX)
	Exterior	Interior	
C1, insignificant		Heated buildings with a neutral atmosphere, e.g. offices, shops, schools, hotels.	Interior doors
C2, low	Atmospheres with a low degree of pollution. Mostly rural areas.	Unheated buildings where condensation can form, e.g. warehouses, sports halls.	Unheated hall
C3, moderate	Urban and industrial atmospheres, moderate pollution from sulphur dioxide. Coastal areas with low salinity.	Production areas with high humidity and some air pollution, e.g. food production plants, laundries, breweries, dairies.	This is only about the climate, not about any cleaning agents used!
C4, heavy	Industrial areas and coastal regions with moderate salinity.	Chemical plants, swimming pools, boathouses over seawater.	Technical release required! Restrictions on warranty and guarantee required! Increased maintenance effort!
C5-I, very heavy	Industrial areas with high humidity and an aggressive atmosphere, as well as coastal areas with heavy salinity.	Buildings or areas with almost constant condensation and heavy pollution.	

### Duration of protection

l – low	short	up to 7 years
m – medium	medium	7 to 15 years
h – high	long	15 to 25 years
vh - very high	very long	> 25 years

## 3.7 Seal

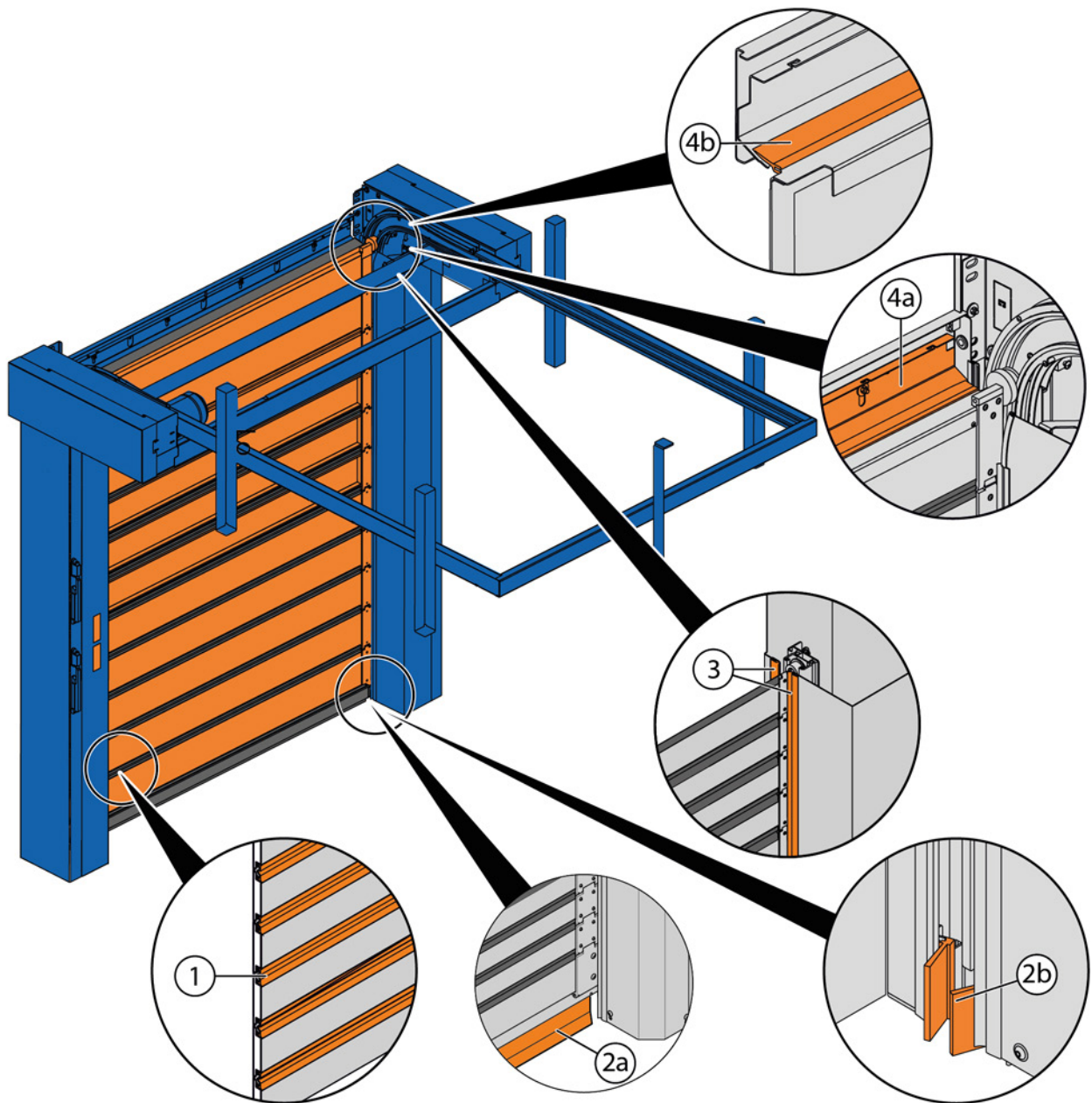

Fig. 56: Seal

The low-wear plastic door leaf seals (Fig. 56/3), which are attached in front of and behind the door leaf, provide the vertical seal. Rubber profiles are used for horizontal sealing to the floor. For design reasons, the length of the rubber profile is B-15 mm (Fig. 56/2a).

Additional seals are therefore attached to the sides (Fig. 56/2b).

The laths are sealed off by rubber hinges, one below the other (Fig. 56/1).

# Construction of the high-speed spiral door

## Control units

An adjustable sealing profile mounted on the lintel and a rubber lip fastened to the top lath seal off the top of the door system. If the door system is closed, the rubber lip seals off the sealing profile (Fig. 56/4b and Fig. 56/4a).

### 3.8 Drives

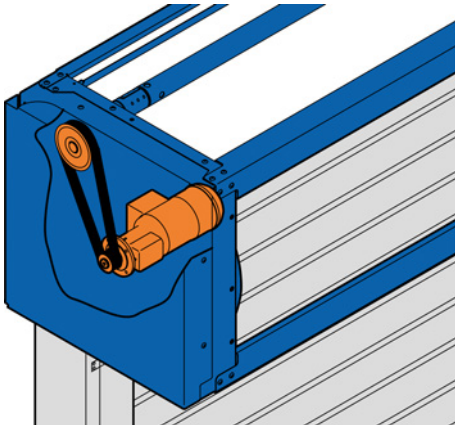

Fig. 57: Drive

All door systems	
Drive type	Integrated into the spiral to save space; transmission of force via toothed belt (Spur gear, asynchronous AC motor)
Power classes	1.5 kW
Protection type	IP54
Position detection	Absolute encoder Thus no reference run is required.

### 3.9 Control units

Door system type	EFA-TRONIC®	EFA-TRONIC® Professional	Installation position
307	●	○	● on the wall or on the side frame on the operator side

- Standard
- Optional

### EFA-TRONIC®

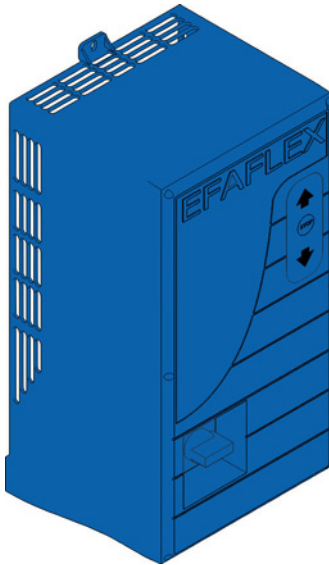

Fig. 58: EFA-TRONIC®

Control unit	EFA-TRONIC® with frequency converter
Size (W × H × D)	210 × 400 (565)* × 200 mm (* incl. cable cover)
Housing	Polycarbonate housing
Protection type	IP65
Viewing window for display	Display of status messages and fault messages
Operating controls	Operating panel for operation and configuration of the door system Master switch
Supply voltage	L/N/PE 230 V ± 10 % or 3~L/N/PE 400 V ± 10 %
Frequency	50 – 60 Hz
Supply cable	Fuse protection 16 A to be provided by the user (K characteristic)
With residual current device (RCD) as necessary	300 mA in compliance with DIN VDE 0100-530 (sensitive to universal current)

## Construction of the high-speed spiral door

Control units

### EFA-TRONIC® Professional

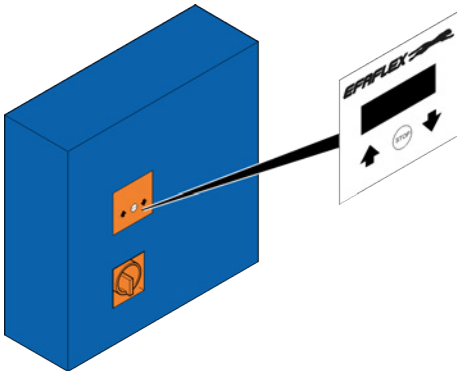

Fig. 59: EFA-TRONIC® Professional

Control unit	EFA-TRONIC® Professional with frequency converter
Size (W × H × D)	380 × 380 × 210 mm 380 × 600 × 210 mm (optional) 600 × 600 × 210 mm (optional)
Housing	Steel, colour RAL 7035 Optional: ■ Painted RAL colours in compliance with SAP ■ V2A
Protection type	IP65
Viewing window for display	Display of status messages and fault messages
Operating controls	Operating panel for operation and configuration of the door system Master switch
Supply voltage	L/N/PE 230 V ± 10 % or 3~L/N/PE 400 V ± 10 %
Frequency	50 – 60 Hz
Supply cable	Fuse protection of 16 A to be provided by the owner (K characteristic)
With residual current device (RCD) as necessary	300 mA in compliance with DIN VDE 0100-530 (sensitive to universal current)

### EFA-HDI® operating unit

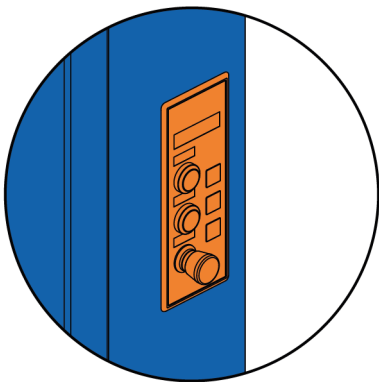

Fig. 60: EFA-HDI® operating unit

It is possible to install an additional operating unit to supplement the EFA-TRONIC®. It is equipped with a display screen and offers full access to all parameters and all basic functions.

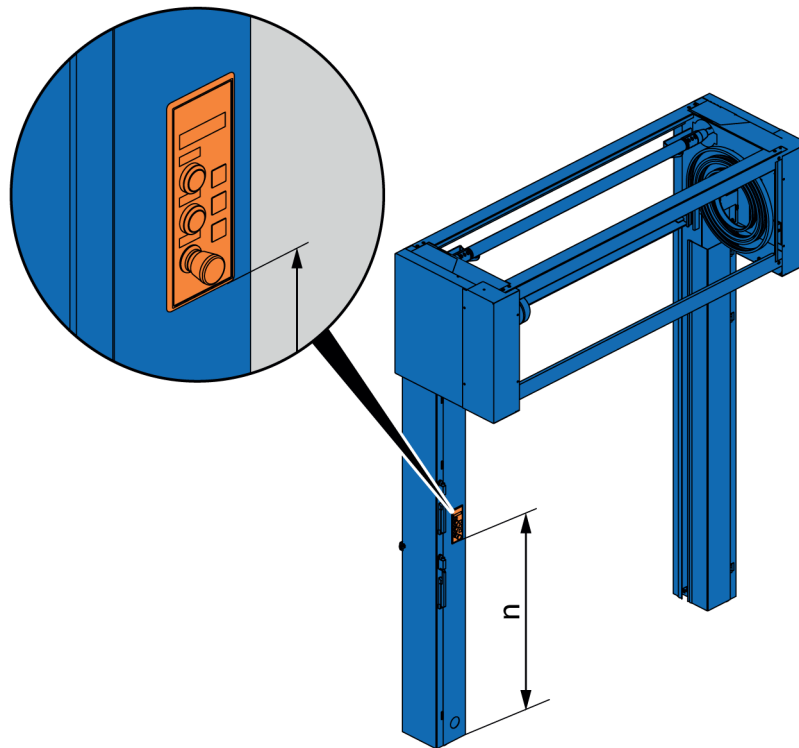

Fig. 61: EFA-HDI®

Only one EFA-HDI® can be used per door system.

n	Dimensions
1310 mm	LH ≥ 2000 mm
LH - 690 mm	LH < 2000 mm

LH = Clear height

## Door safety

Door light grid

### 4 Door safety

#### Available door safety

Door system type	Door light grid	Door light grid and safety edge	Safety edge and light barrier
307	•	○	○

- Standard
- Optional



*Extension of the closing strip is an exception ( ↗ Chapter 3.4.6 'Flexible closing strip extension' on page 28):*

- *The safety edge and the door light grid are always pre-assigned.*



*Simultaneous installation of a door light grid and light barrier(s) is not possible.*

The main closing edge is secured by a combination of a safety edge and light barrier(s) (C device plus D device). This achieves the minimum protection level in line with DIN EN 12453.



*In addition, the owner and the manufacturer have to consult with one another on providing protection for the approach area. This is based on the owner's risk assessment.*

#### 4.1 Door light grid

Door light grids, which are used for personal protection, can be installed horizontally and vertically.

The vertical door light grids are described in the next chapter, see ↗ page 53.

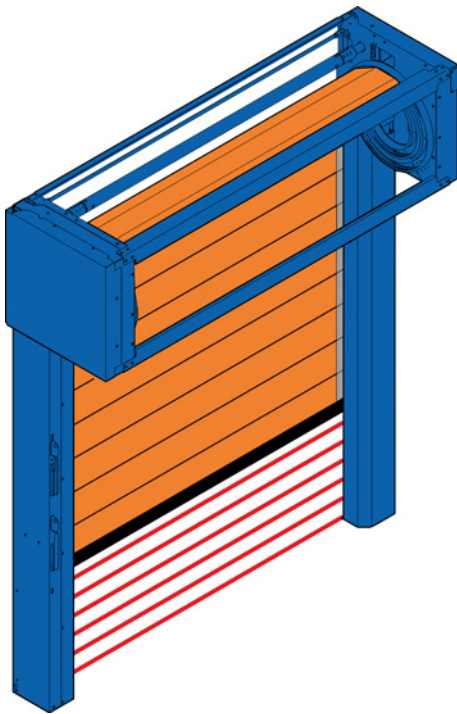

Fig. 62: Door light grid

The door light grid, which is installed in the side of the side frame, monitors the closing level, up to a height of 2.5 metres. The door light grid prevents the door system from closing when a person is detected in the danger area.

On door systems, an optional safety edge can be installed in addition to the door light grid. Simultaneous installation of a door light grid and light barrier is not possible.

### 4.2 Safety edge and light barrier

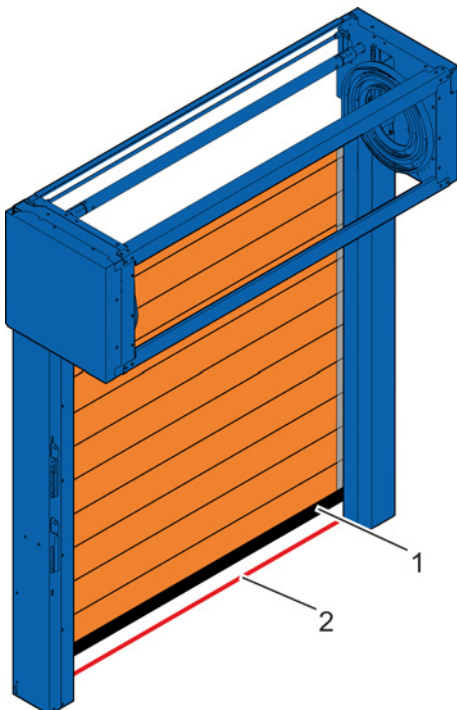

Fig. 63: Safety edge and light barrier

1	Safeguard for closing edge	Safety edge
2	Light barrier (optional)	Unidirectional light barriers (IP67) max. 2

If the safety edge comes into contact with a person during the closing procedure, the door leaf stops, the door system opens completely and closes automatically again once the "keep-open" time has elapsed.

The light barriers, which are installed in the side frames at the sides, are offset from the door closing level. The height of the light barriers is variable.

### 4.3 EFA-SCAN®

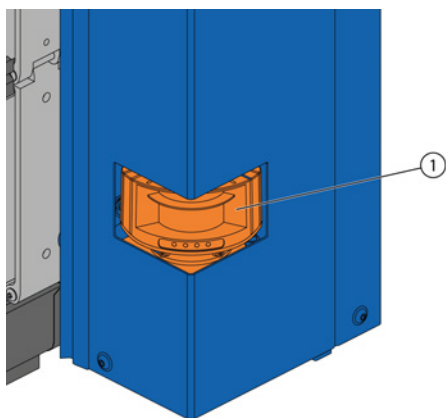

In addition to the main closing edge safeguard, the EFA-SCAN® (Fig. 64/1) can be integrated into the side frame opposite the operator side. Simultaneous selection of limit switches and EFA-SCAN® in SAP is not possible due to space restrictions.

Fig. 64: EFA-SCAN®

## 5 Equipment packages

### Cold 1

This package provides the door system with the necessary equipment for use in the following temperature ranges:

Use	Temperature range
Area in front of door system	From -1 °C to -25 °C
Area behind door system	From -1 °C to -25 °C

Door system types	Laths
307	EFA-THERM® laths EFA-CLEAR® transparent laths double-walled only with hard poly-carbonate panes (scratch resistant)

#### Equipment

- Motor heating
- Basic control cabinet heating (sufficient down to -25 °C)
- Drive/gearbox with low temperature resistant oils and greases (suitable down to -25 °C)
- Door light grid (areas with high humidity are excluded in this temperature range, "Fogging" therefore only occurs to a limited extent and does not impair the door light grid.)
- EFA-TRONIC® Professional control unit
- Control cabinet size 600 x 600 mm
- Door leaf toothed belt with special low temperature resistant plastic compound
- Optional: External light barrier

### Processes

This package provides the door system with the appropriate equipment to be operated by a master control unit, with and without special requirements under the Machinery Directive.

#### Equipment

- Limit switches with functional safety requirements under Machinery Directive for evaluation in master control unit.
- Control unit in steel housing with master switch as emergency stop switch (red/yellow), alternatively in black design
- Operating controls exclusively inside the control unit housing

- Housing lockable
- Predefined I/O control interface on terminal strip
  - "Door open" (potential-free)
  - "Door closed" (potential-free)
  - "Door ready" (potential-free)
  - Open and close operation using pulse control
  - Emergency stop input

### Security 1

This package provides the door system with the appropriate equipment to meet the requirement for "Alarm system for loss prevention (VdS)", including control input for blocking the pulser. See [VdS Schadenverhütung GmbH](#).

#### Equipment

- Mechanical locking mechanism
- Depending on customer requirements, the following "roll-up door contacts" can be selected in SAP:
  - LSN/VdS B
  - CT/VdS B
  - LSN/VdS C
  - CT/VdS C

CT: Conventional technology

LSN: Local Security Network

### Security 2

This package provides the door system with the appropriate equipment to meet the requirement for "Alarm system for loss prevention (VdS)", including control input for blocking the pulser. See [VdS Schadenverhütung GmbH](#).

#### Equipment

- Automatic locking mechanism
- Resistance class WK2/RC2
- Depending on customer requirements, the following "roll-up door contacts" can be selected in SAP:
  - LSN/VdS B
  - CT/VdS B
  - LSN/VdS C
  - CT/VdS C

CT: Conventional technology

LSN: Local Security Network

### Special constructions

Special constructions/special orders are design types which are not covered, either mechanically or electrically, by standard versions in the sales price lists or by a design from the technology variants table. They have to be requested specifically. Surcharges and extended delivery times are calculated for special designs in accordance with the actual expenditure.

### 6 Surface design drawings

The design drawings indicate which surfaces are coated and which components have a V2A design.

Powder coating (Z4) or wet varnish (LAS)

- Only externally visible surfaces are coated.
- Connecting components (e.g. screw heads) are not coated.  
See ↪ *Chapter 3.6.1 'Corrosion protection' on page 43.*

Stainless steel design V2A (Z6)

- Some internal small parts do not have a V2A design.  
See ↪ *Chapter 3.6.1 'Corrosion protection' on page 43.*



*The following drawings are example representations of the component positions and may differ from the actual product. Not all components are illustrated.*

## Surface design drawings

Component coating type

### 6.1 Component coating type

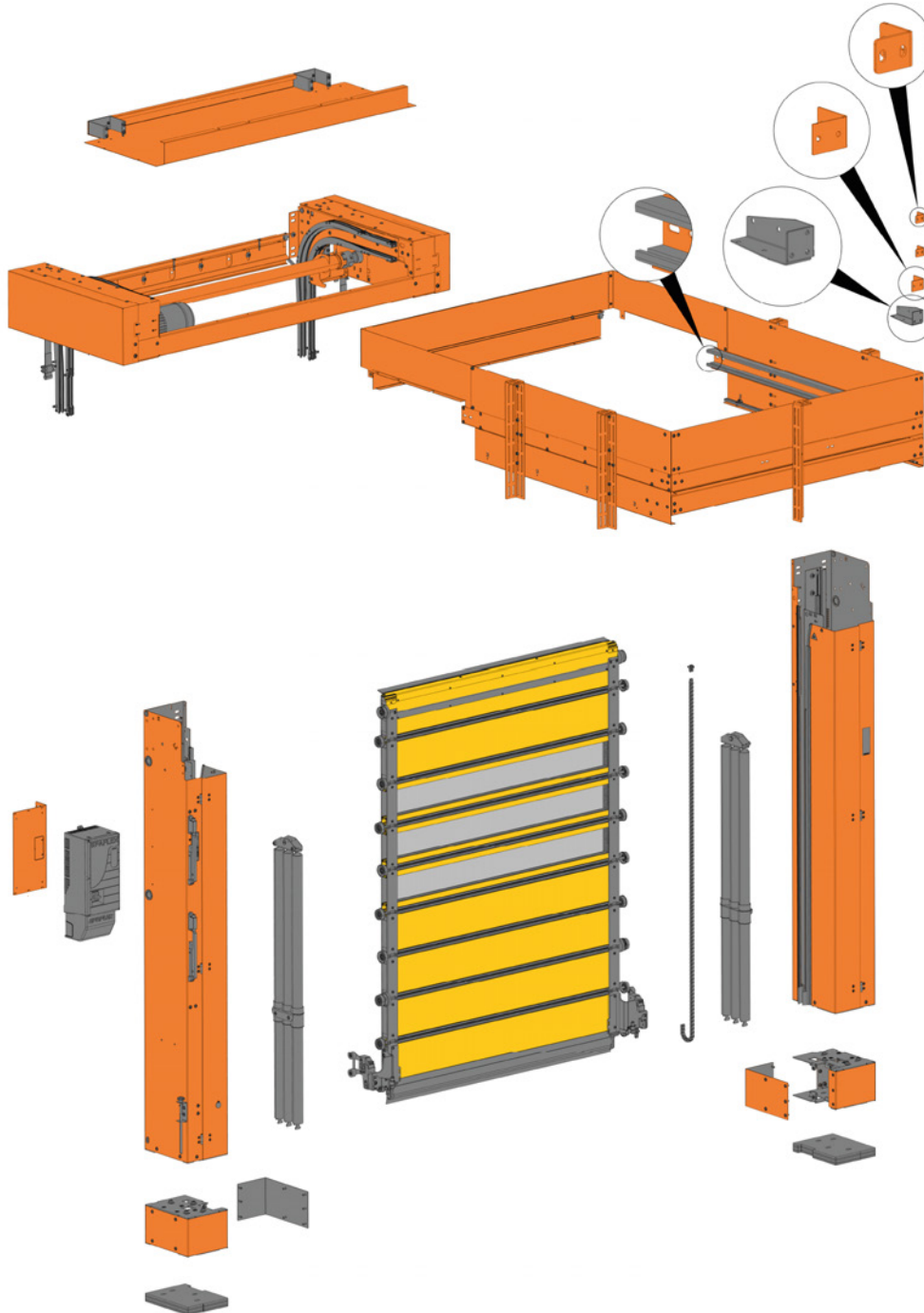
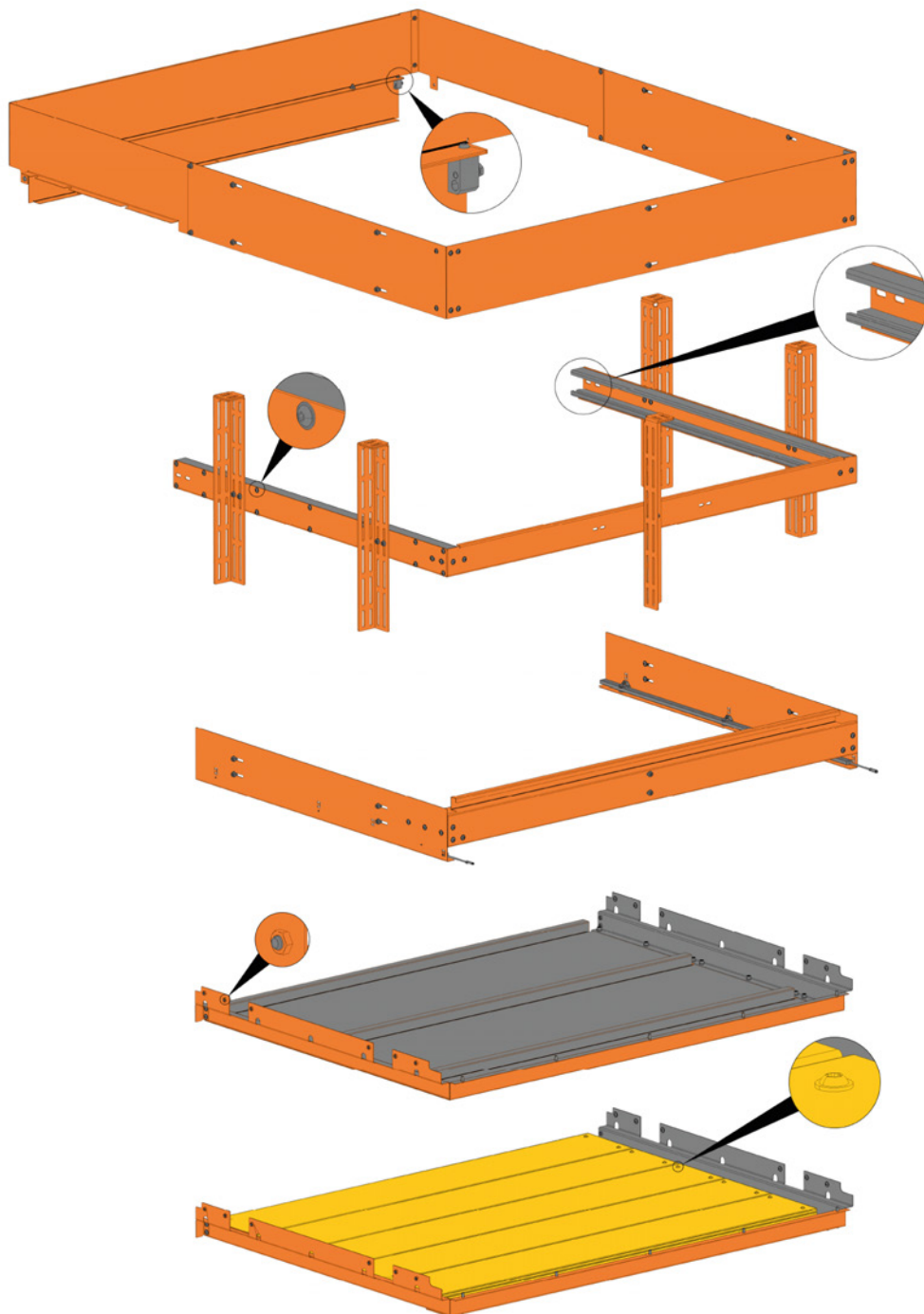

Fig. 65: Coating for door system type 307

Orange Powder coating  
Yellow Wet coating  
Grey No coating possible

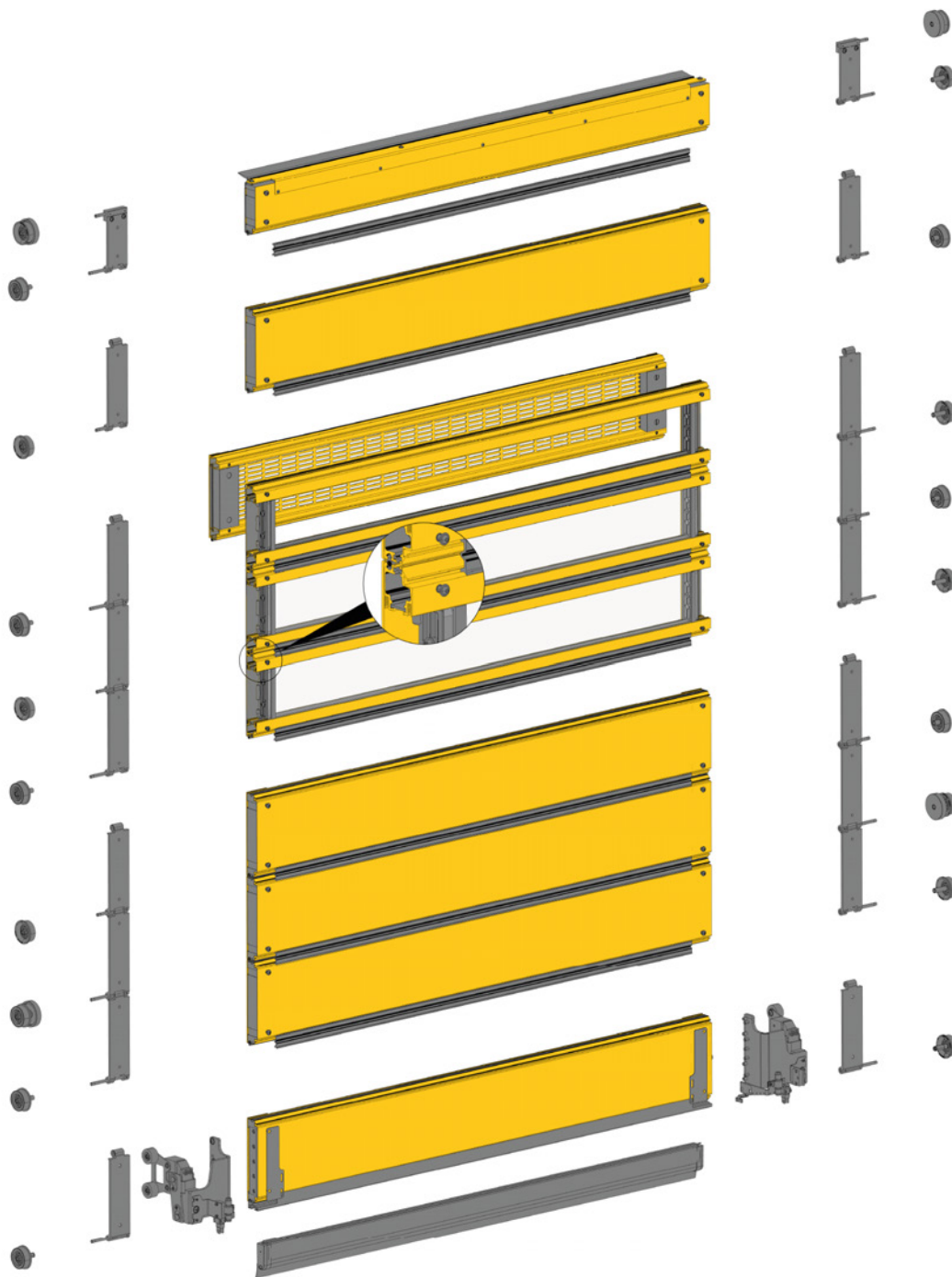

*Fig. 66: Coating for spiral case and horizontal guide*

Orange Powder coating  
 Yellow Wet coating  
 Grey No coating possible

## Surface design drawings

Component coating type



*Fig. 67: Coating for door leaf*

Yellow Wet coating

Grey No coating possible

## 6.2 Stainless steel design components (V2A)

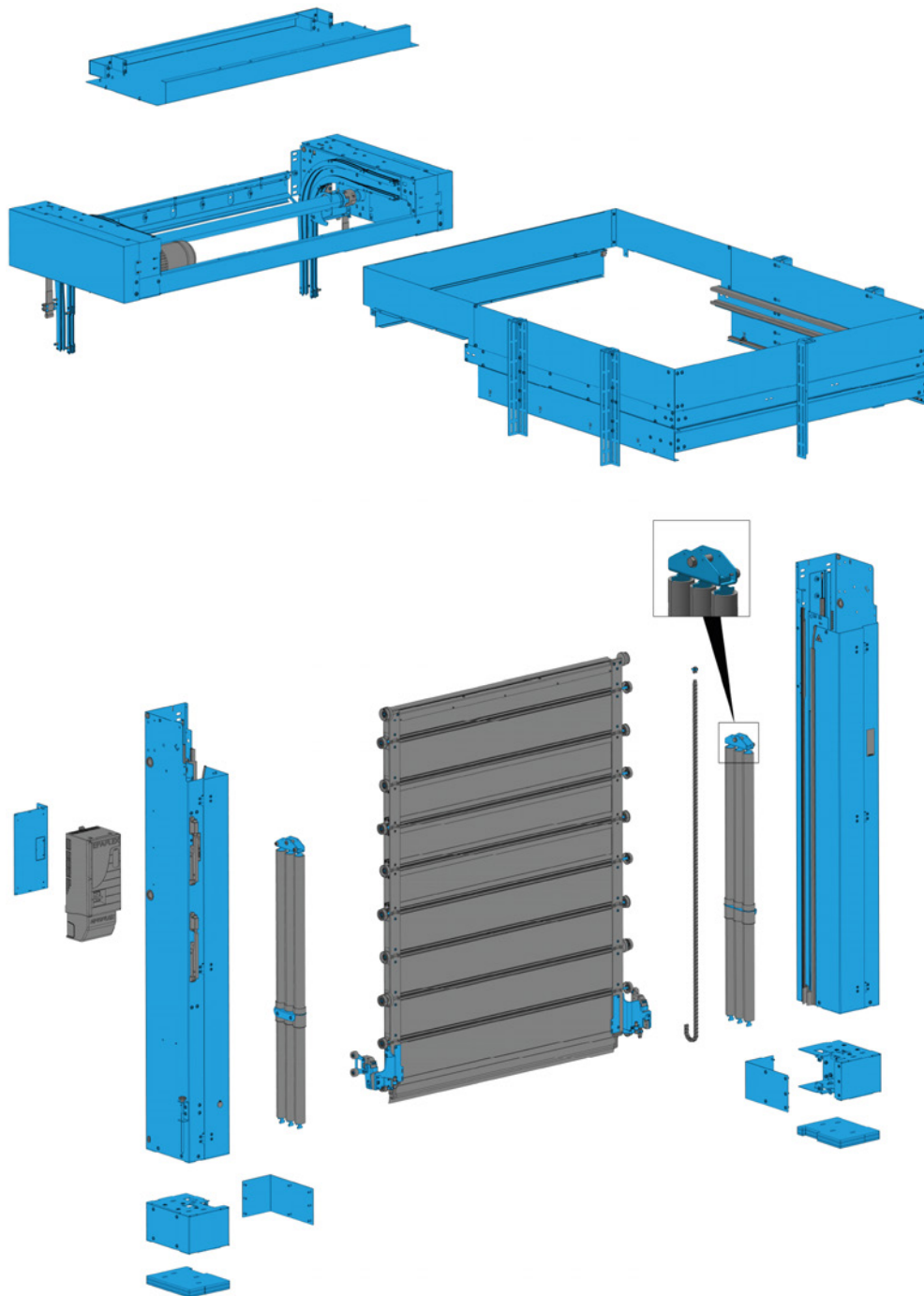
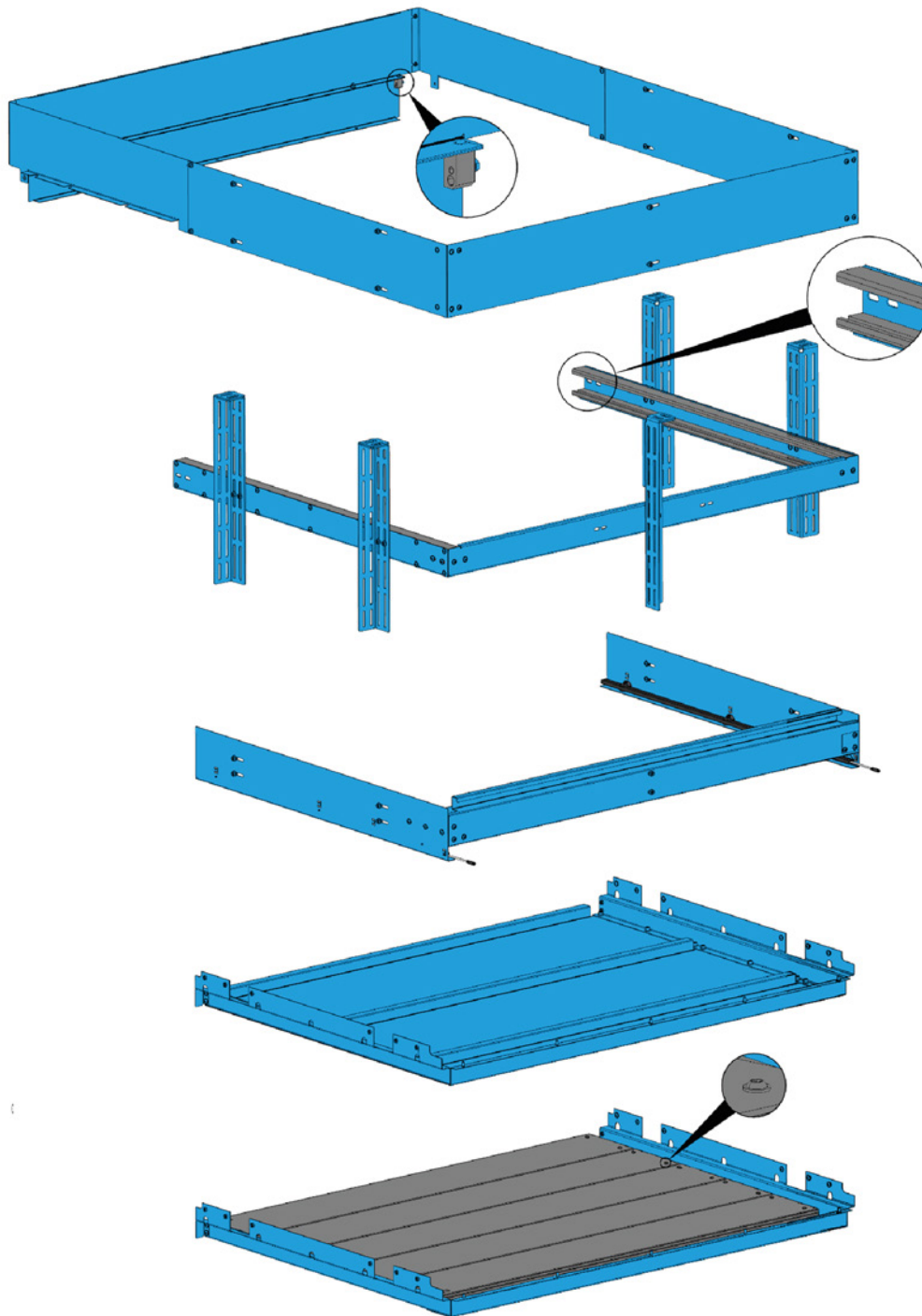

Fig. 68: Complete door system  
Light blue V2A

## Surface design drawings

Stainless steel design components (V2A)



*Fig. 69: Spiral case and horizontal guide*

Light blue V2A

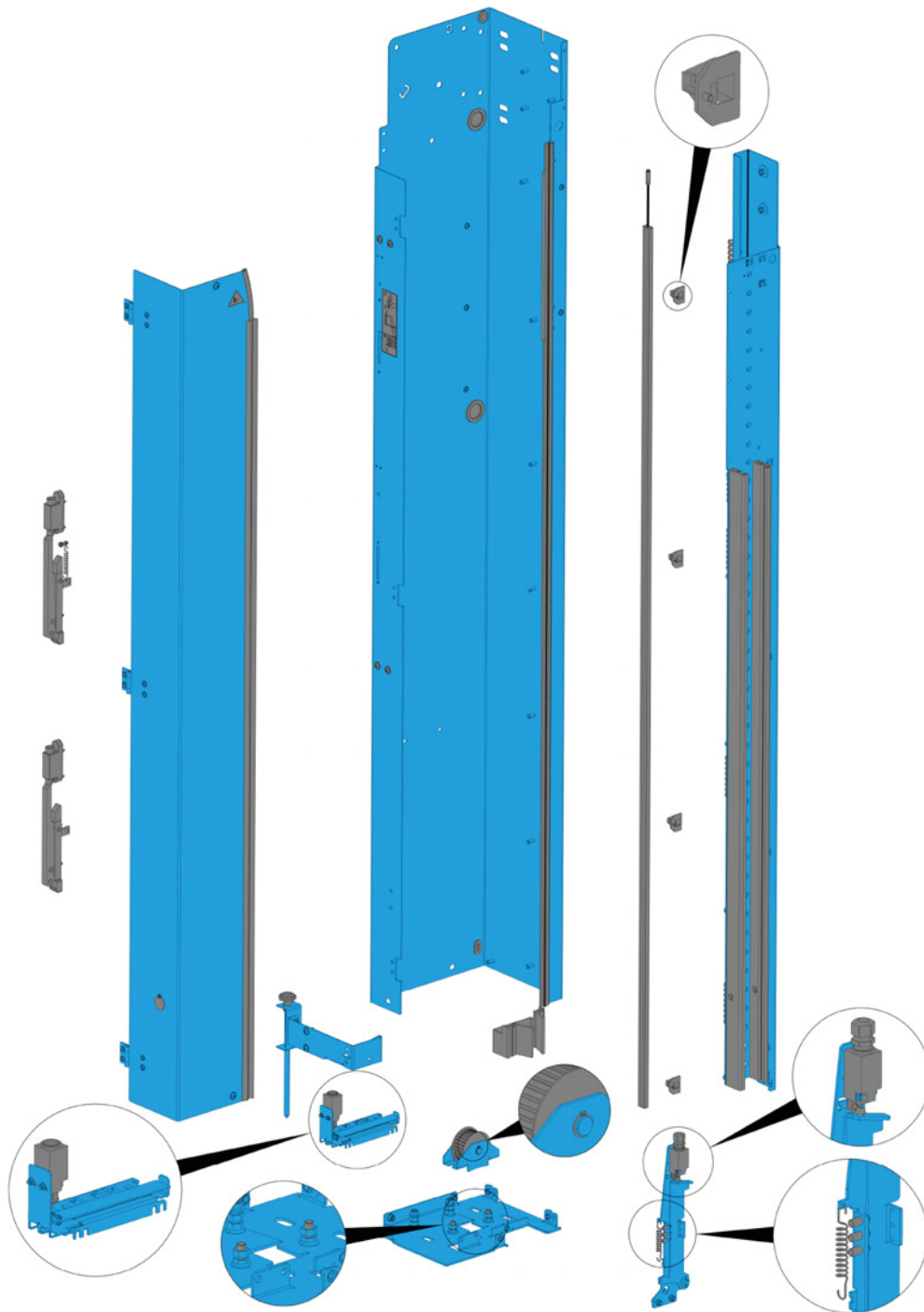
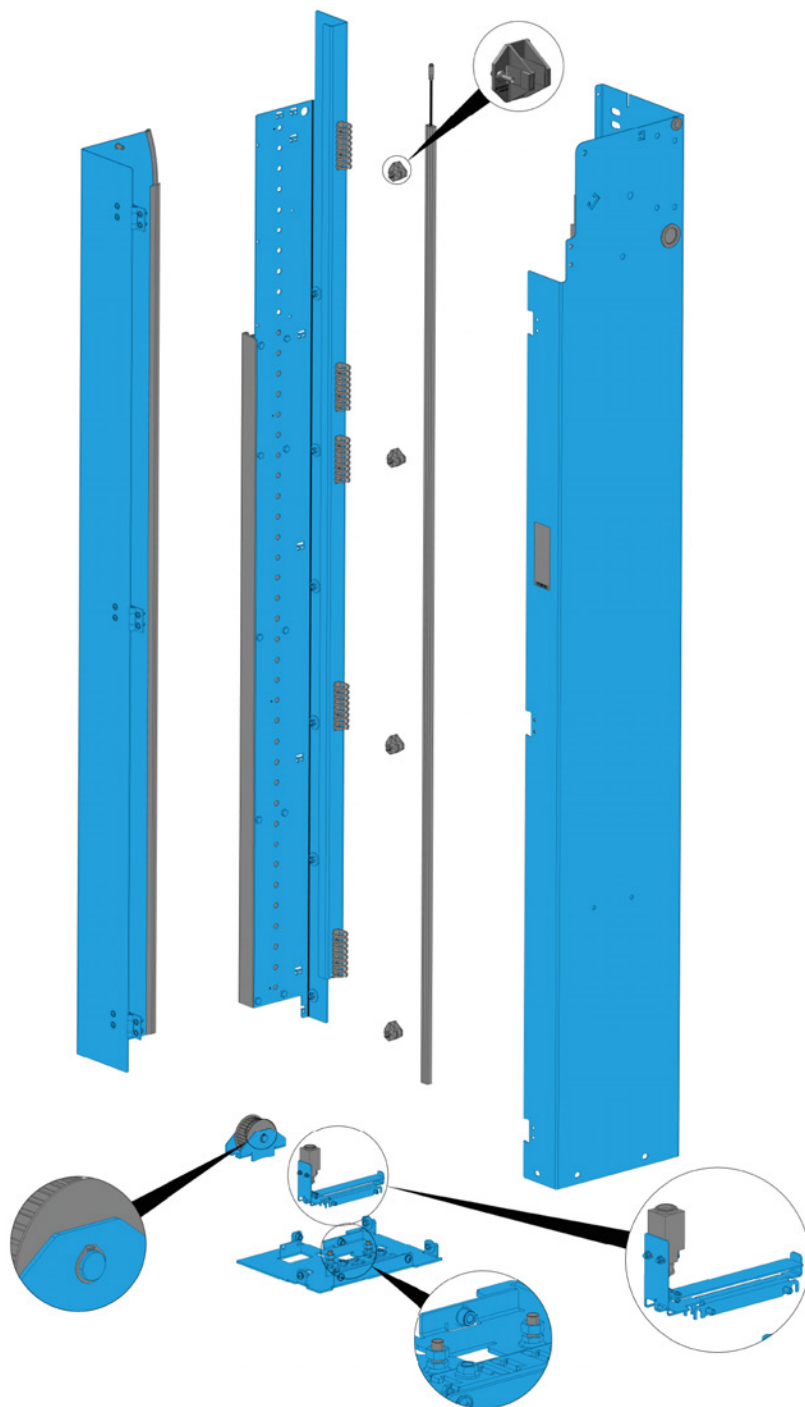

Fig. 70: Left side frame

Light blue V2A

## Surface design drawings

Stainless steel design components (V2A)



*Fig. 71: Right side frame*

Light blue V2A

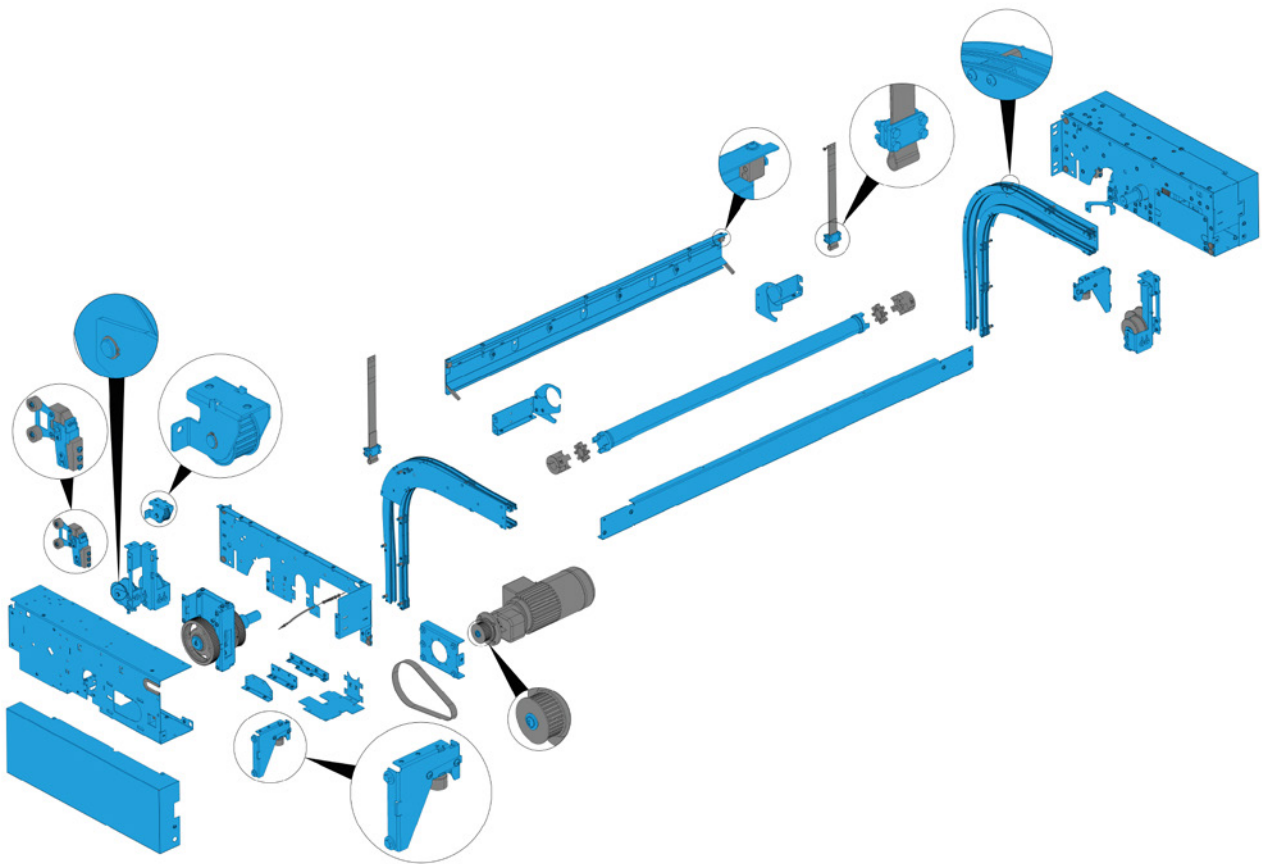

*Fig. 72: Spiral case, parts*  
Light blue V2A

## Surface design drawings

Stainless steel design components (V2A)

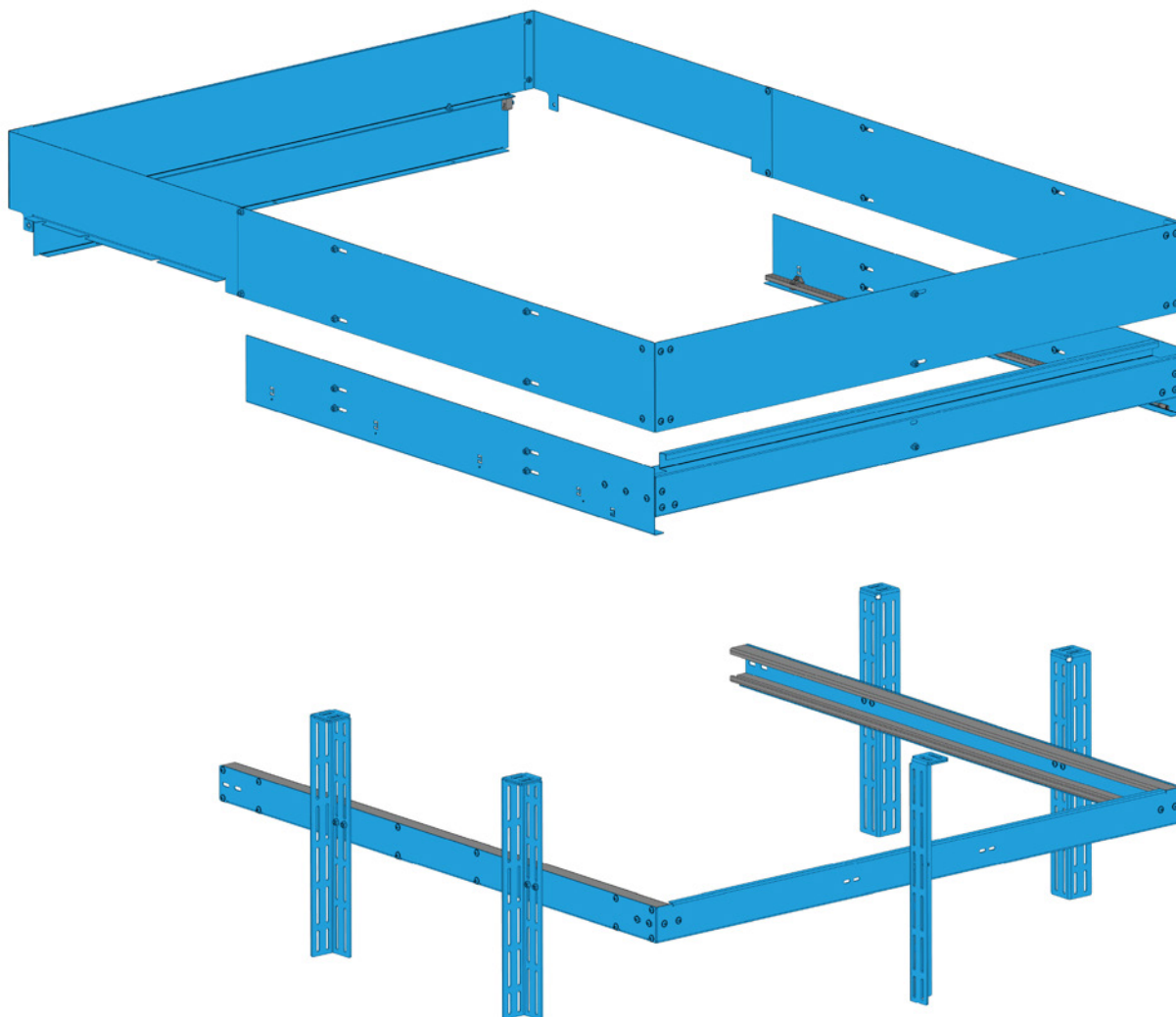

*Fig. 73: Spiral case*

Light blue V2A

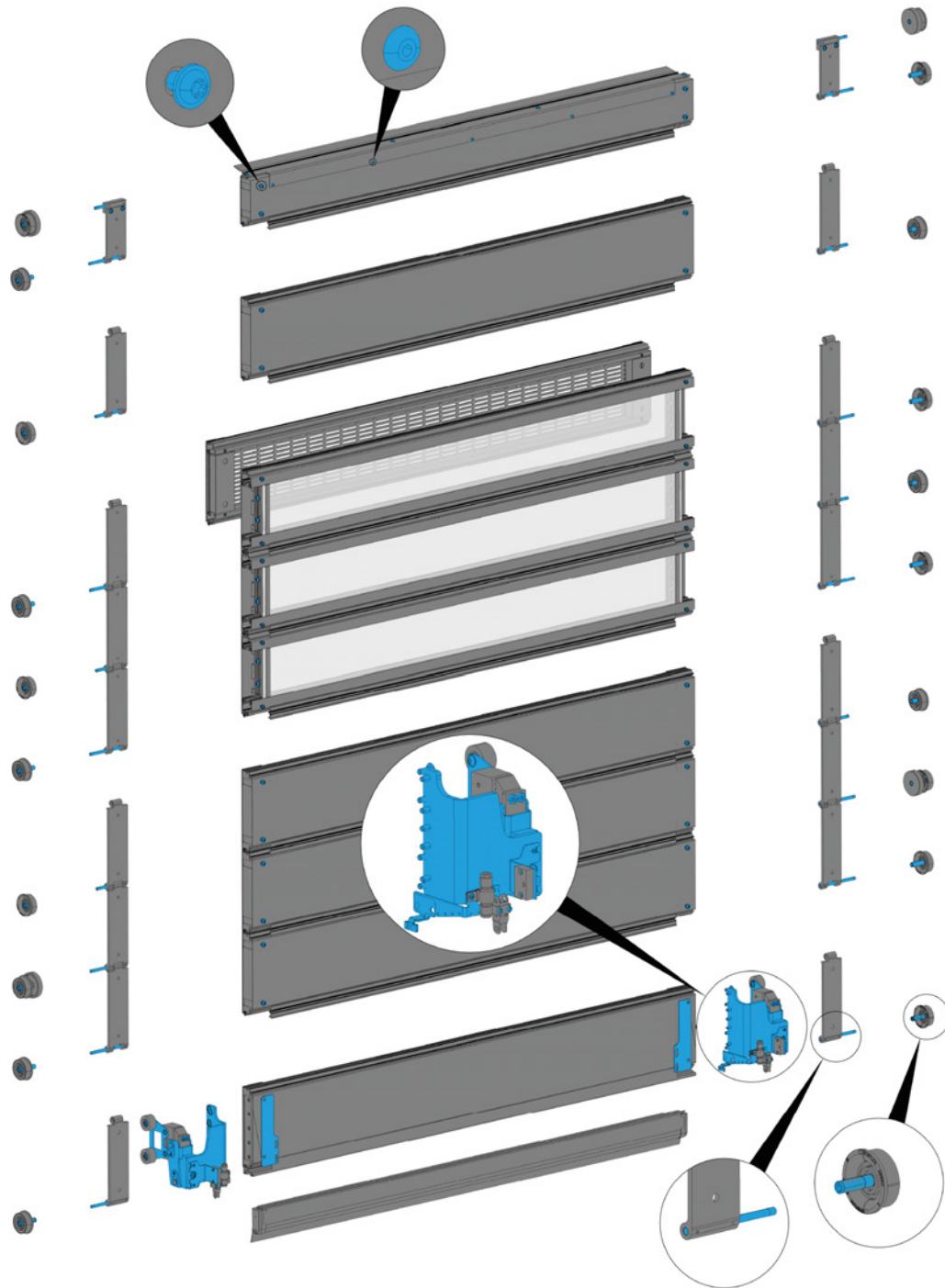

*Fig. 74: Door leaf*  
Light blue V2A

## 7 Packaging units

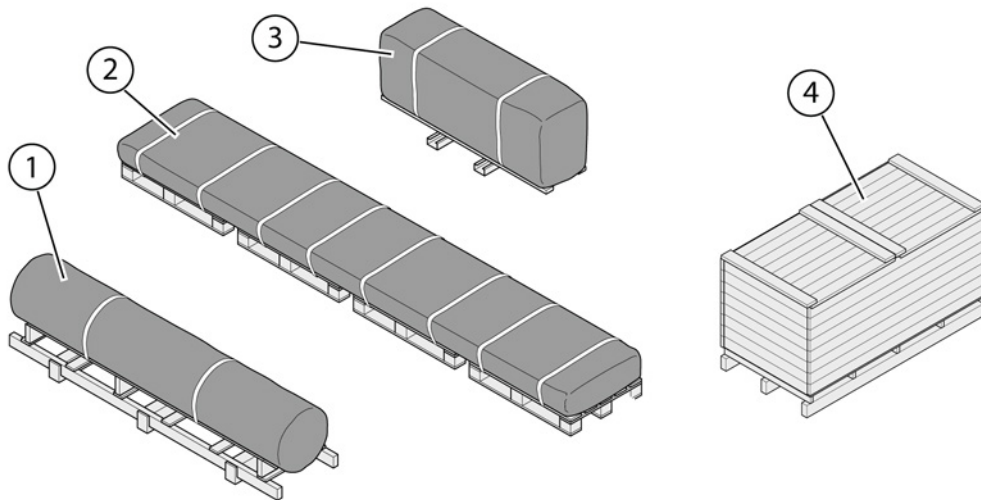

Fig. 75: Scope of delivery (1 – 3, standard transport unit), wooden crate 4 (optional), for sea and fit-for-purpose\* transport and/or for horizontal guide cover with laths (see Fig. 9).



*\*Fit-for-purpose packaging is packaging that ensures that the packaged goods reach the recipient without damage, taking into account the shipping loads, shipping route, shipping duration and transportation load profile.*

### Transport unit (example)

Transport unit 1: Door leaf package ("low lintel" version only)

Transport unit 2: Side frame sections with covers, control unit, accessories

Transport unit 3: Console package

Transport unit 4: Wooden crate (optional)

### Number of transport units

The number of standard transport units depends on the selected number of door systems.

The door systems can also be delivered in a wooden crate. The number of wooden crates depends on the configuration of the door system types and the number of door systems.

Wood that complies with the IPPC standard is optionally available. For sea freight, the wooden crates are lined with film as protection against moisture.

Packages attached to pallets can be transported by forklift under the following conditions:

- The forklift must have the appropriate capacity for the weight of the packages.
- The package must be securely fastened to the pallet.
- The forklift driver must be authorised to drive industrial trucks with a driver's seat or driver's station in accordance with the local regulations.







EFAFLEX Tor- und Sicherheitssysteme

GmbH & Co. KG

Fliederstraße 14

84079 Bruckberg

GERMANY

Telephone: +49 8765 82-0

Fax: +49 8765 82-200

Email: [info@efaflex.com](mailto:info@efaflex.com)

Internet: [www.efaflex.com](http://www.efaflex.com)