



***Technical product description***  
***High-speed spiral door***  
***Efficient***



*For internal use only*

This technical product description  
applies to the following door system type:  
EFA-SST®-L Efficient

EFAFLEX Tor- und Sicherheitssysteme GmbH & Co. KG  
Fliederstraße 14  
84079 Bruckberg  
Germany  
Telephone: +49 8765 82-0  
Fax: +49 8765 82-200  
Email: [info@efaflex.com](mailto:info@efaflex.com)  
Internet: [www.efaflex.com](http://www.efaflex.com)

Translation of the original  
Version 03-EN

21.10.2021

© EFAFLEX Tor- und Sicherheitssysteme GmbH & Co. KG

---

Door system designations

| Official designation of the door system | Spiral type  | Designation of the door system in this product description |
|---|--------------|--|
| EFA-SST®-L Efficient                    | Round spiral | 314  |

## **Table of contents**

|          |   |           |
|----------|---|-----------|
| <b>1</b> | <b>Short description.....</b>                   | <b>5</b>  |
| <b>2</b> | <b>Technical properties.....</b>                | <b>7</b>  |
| <b>3</b> | <b>High-speed spiral door construction.....</b> | <b>10</b> |
| <b>4</b> | <b>Door safety.....</b>                         | <b>29</b> |
| <b>5</b> | <b>Equipment.....</b>                           | <b>30</b> |
| <b>6</b> | <b>Packaging units.....</b>                     | <b>31</b> |

## 1 Short description

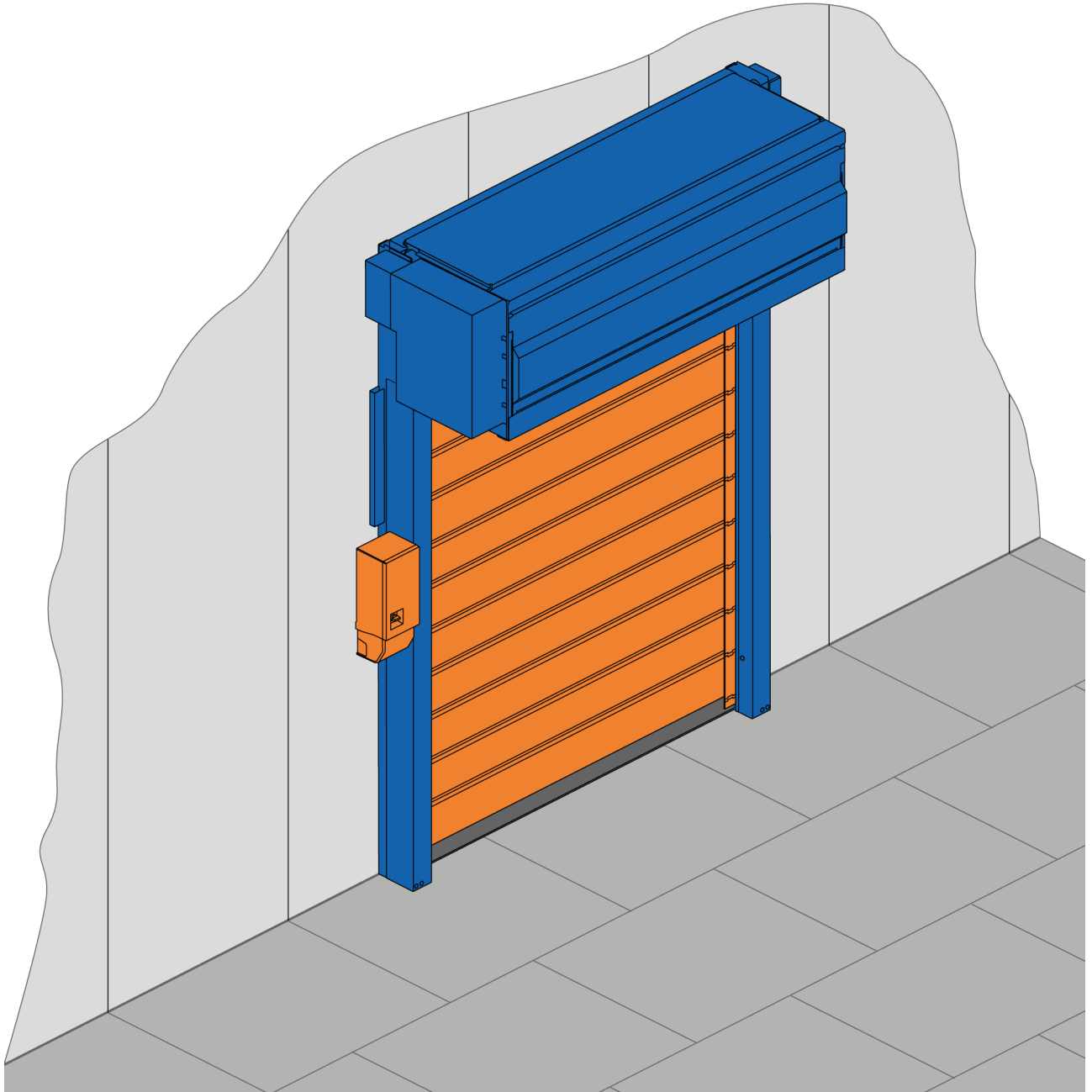

*Fig. 1: High-speed spiral door*

The EFA-SST®-L Efficient high-speed spiral door is designed for medium frequency of use and door leaf speed requirements. The standard version and available options were reduced to minimum requirements.

## Short description

The door leaf and the technology used, such as a chain for force transmission and a drive with worm gear, make the likes of compact side frame dimensions possible. Type 314 is virtually maintenance-free due to the elimination of the counterbalance system. Due to the selected drive system and certain features ( ↶ 'Drive' on page 25) the door achieves the following resistance classes:

Resistance class 2

- (WK2) as defined in DIN V ENV 1627:1999-04
- (RC2) as defined in DIN/TS 18194:2020

The door leaf is wound onto a round spiral.

The highly insulated door leaf is made of 40 mm-thick EFA-THERM® steel plate laths. EFA-CLEAR® transparent laths with transparent SAN or PC hard panes or EFA-VENT® ventilation laths can be selected as options.

The double-walled and single-walled EFA-CLEAR® transparent laths are available with a frosted glass finish (opal) with 75% translucency as an option.

## 2 Technical properties

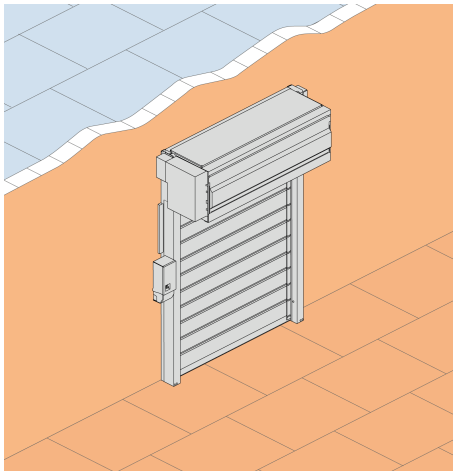

Fig. 2: Use

### Use

- Industrial door
- Hall door
- Outdoor installation under a canopy provided by the owner (installation of the control unit: > +5 °C)

|  |                            |
|--|----------------------------|
|  | Outdoor (-15 °C to +50 °C) |
|  | Indoor (+5 °C to +50 °C)   |

**i** The control cabinet must be installed in an ambient temperature of > +5 °C.

### Dimensions

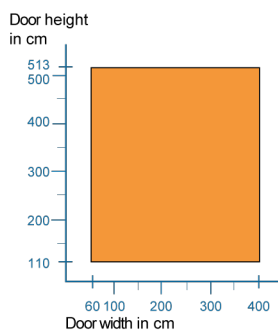

Fig. 3: Diagram of possible door system heights and door system widths

### Door system heights and widths (inner clear height)

| Door system type | Widths        | Heights        |
|------------------|---------------|----------------|
| 314              | 600 – 4000 mm | 1100 – 5130 mm |

### Speeds

| Door system type | Average speed |  |
|------------------|---------------|--|
|                  | Opening speed | Closing speed with safety edge and light barrier |
| 314              | 0.5 m/s       | 0.5 m/s  |

## Technical properties

### Performance properties in accordance with DIN EN 13241

| Specification   | Door system width/size/other specifications               | Value                       |
|---|---|-----------------------------|
| Resistance to wind load in compliance with DIN EN 12424         | $600 \text{ mm} \leq B \leq 3000 \text{ mm}$              | Class 4                     |
|   | $3000 \text{ mm} < B \leq 3500 \text{ mm}$                | Class 3                     |
|   | $3500 \text{ mm} < B \leq 4000 \text{ mm}$                | Class 2                     |
| Resistance to water penetration in compliance with DIN EN 12425 | -   | Class 2                     |
| Air permeability in compliance with DIN EN 12426                | -   | Class 0                     |
| Airborne sound insulation in compliance with EN ISO 717-1       | Only for EFA-THERM® lath                                  | Rw = 20 dB                  |
| Thermal insulation in compliance with DIN EN 12428              | Only for EFA-THERM® lath at $4000 \times 5130 \text{ mm}$ | U = 1.70 W/m <sup>2</sup> K |

### Fire performance as per DIN 4102

| Indication     | Value                   |
|----------------|-------------------------|
| Material class | B2 normally inflammable |

### Performance

| Door system type | Load cycles per year | Life cycle |
|------------------|----------------------|------------|
| 314              | 150,000              | 10 years   |

### Applicable regulation, safety standards and directives

The following regulation, standards and directives were taken into account in planning, engineering and production:

#### Regulation

|              |   |
|--------------|---|
| EUV 305/2011 | Regulation (EU) No 305/2011 of the European Parliament and of the Council of 9 March 2011 laying down harmonised conditions for the marketing of construction products and repealing Council Directive 89/106/EEC |
|--------------|---|

#### Directives

|            |   |
|------------|---|
| 2006/42/EC | DIRECTIVE 2006/42/EC OF THE EUROPEAN PARLIAMENT AND COUNCIL of 17 May 2006 on machinery, and amending Directive 95/16/EC  |
| 2014/30/EU | DIRECTIVE 2014/30/EU OF THE EUROPEAN PARLIAMENT AND COUNCIL of 26 February 2014 on harmonisation of the laws of the member states relating to electromagnetic compatibility   |
| 2014/35/EU | DIRECTIVE 2014/35/EU of the European Parliament and Council of 26 February 2014 on harmonisation of the laws of the member states relating to the making available on the market of electrical equipment designed for use within certain voltage limits |

#### Standards

|                    |  |
|--------------------|--|
| DIN EN 13241       | Doors – Product standard, performance characteristics  |
| DIN EN ISO 13849-1 | Safety of machinery – Safety-related parts of control systems – Part 1 General principles for design |
| DIN EN ISO 13849-2 | Safety of machinery – Safety-related parts of control systems – Part 2 Validation                    |
| DIN EN ISO 12100   | Safety of machinery – General principles for design – Risk assessment and risk reduction             |

## 3 High-speed spiral door construction

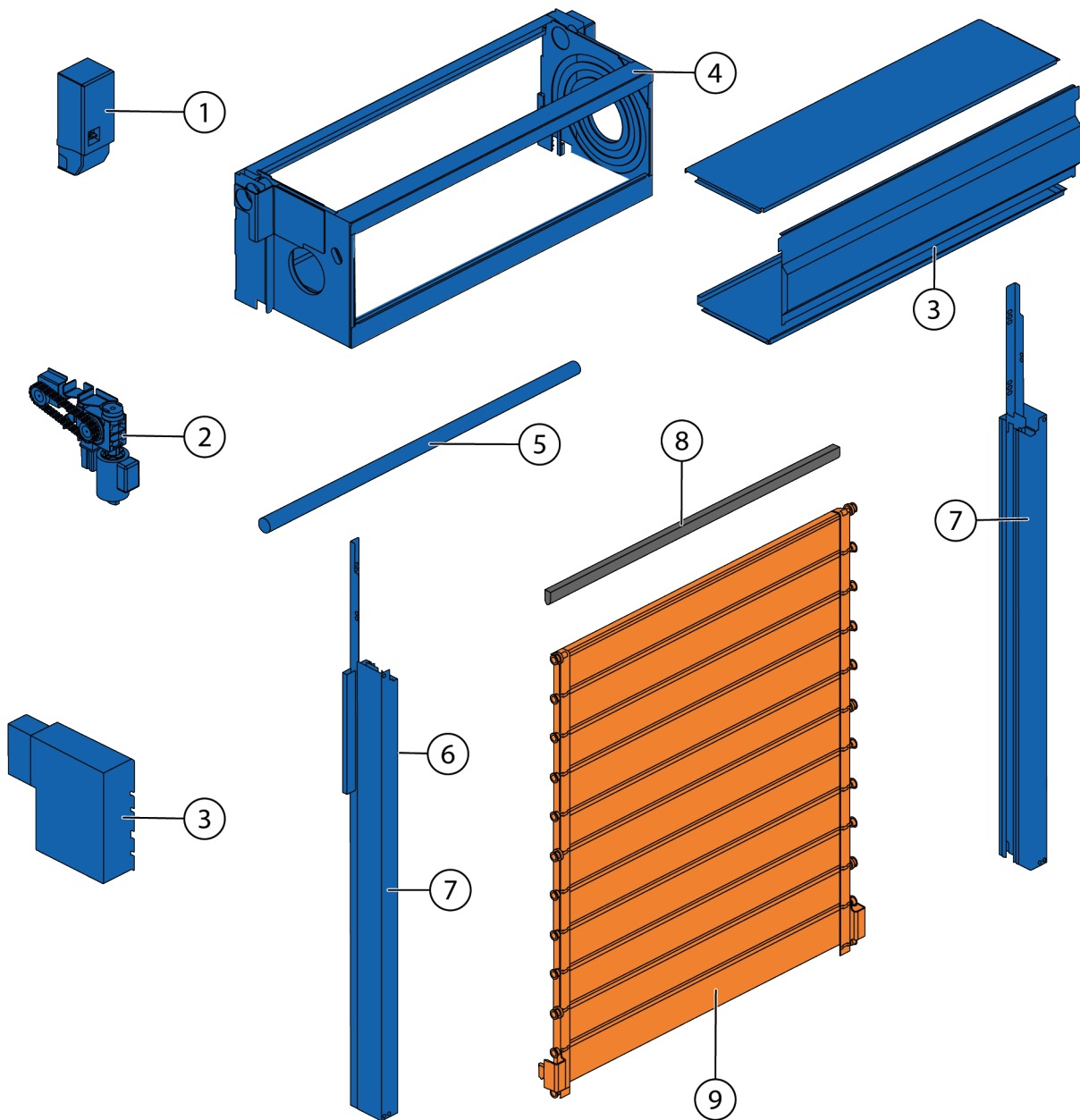
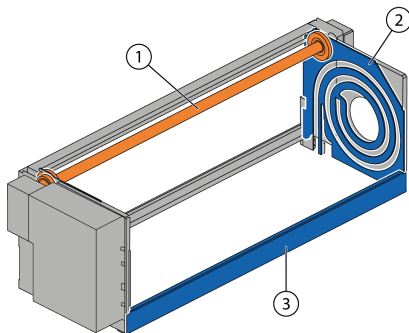

Fig. 4: Assemblies

|   |   |   |
|---|---|---|
| 1 | Control unit                                | ↳ 'EFA-TRONIC® control' on page 26 and<br>↳ 'EFA-TRONIC® Professional' on page 27 |
| 2 | Drive                                       | ↳ 'Drive' on page 25  |
| 3 | Spiral console case (optional)              | ↳ 'Spiral case cover (optional)' on page 11                                       |
| 4 | Spiral case with main support, spiral guide | ↳ 'Spiral case' on page 11  |

|         |  |   |
|---------|--|---|
| 5       | Synchronous shaft  | ↳ 'Spiral case' on page 11  |
| 6 and 7 | Side frames with vertical door leaf guide, door leaf chain | ↳ 'Vertical side frame with door leaf guide' on page 14<br>↳ 'Transmission of force' on page 12 |
| 8       | Horizontal seal  | ↳ 'Seal' on page 24   |
| 9       | Door leaf  | ↳ 'Door leaf' on page 16  |
|         | Laths  | ↳ "Overview of laths", starting on page 17  |
|         | Safety edge  | ↳ "Safety edge and light barrier" starting on page 29   |

## Spiral case



The spiral case comprises:

- Synchronous shaft with bearing (Fig. 5/1)
- Bevelled, main supports with spiral guide (Fig. 5/2) on both sides
- Sheet metal reinforcement profiles (Fig. 5/3)

Fig. 5: Spiral case

## Spiral case cover (optional)

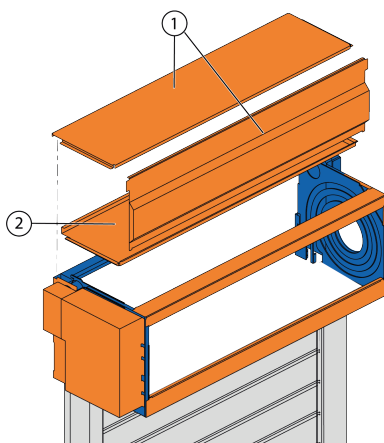

Fig. 6: Spiral case cover

The spiral case can optionally be covered at the bottom, front and top. The covers on the front and bottom (Fig. 6/1 and Fig. 6/2) are only possible in combination. The top cover is only possible if the front and bottom are not covered too.

**The bottom and front cover reduce the clearance height by 20 mm.**



*The cover on the spiral case as finger protection is regulation for door systems with a height of less than 2500 mm.*

### Transmission of force

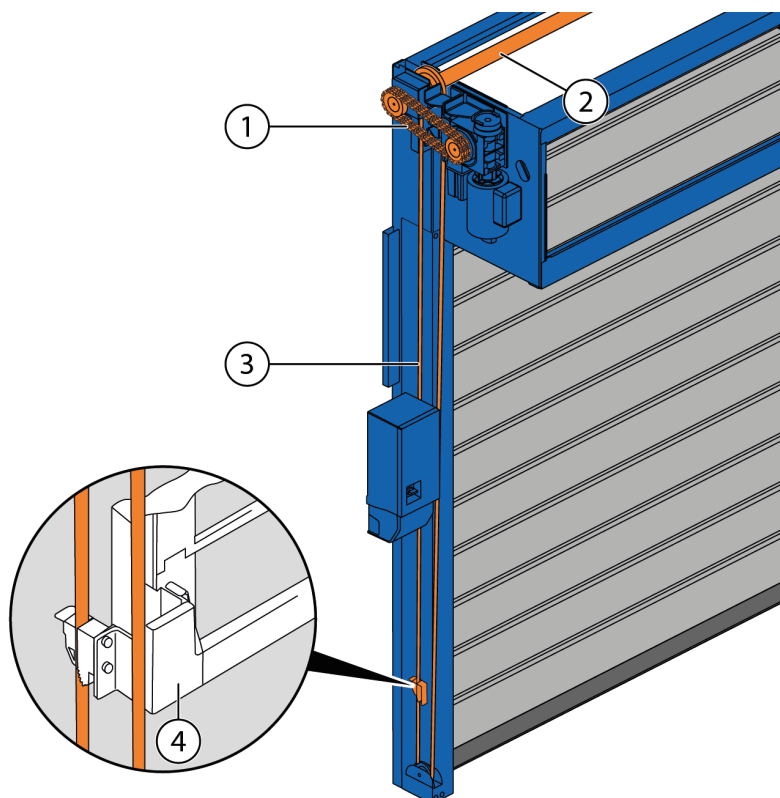
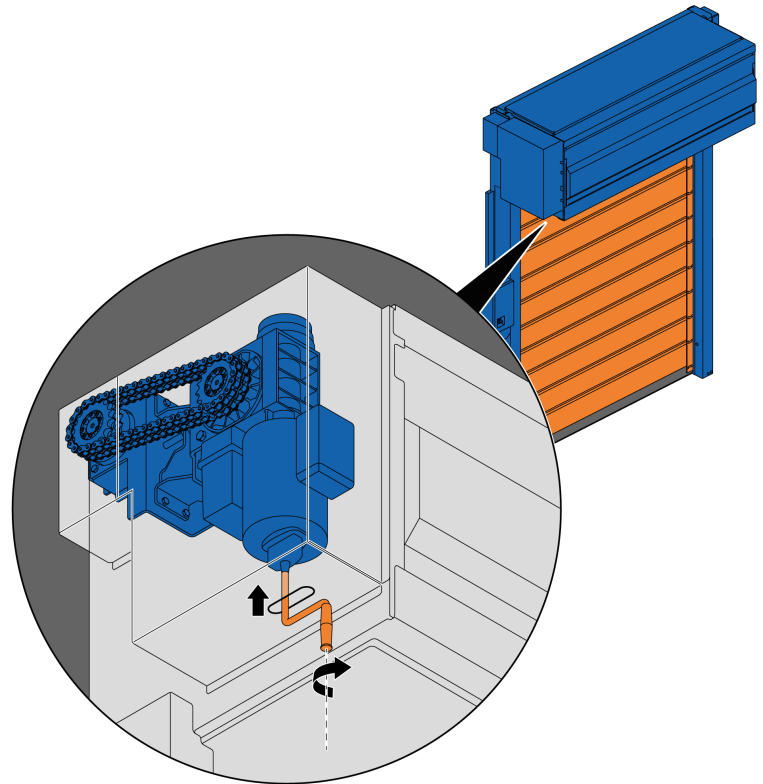

*Fig. 7: Transmission of force*

The transmission of force from the drive to the door leaf is performed by the drive chain (Fig. 7/1), synchronous shaft (Fig. 7/2), the continuous chains (Fig. 7/3) and the door leaf mounts (Fig. 7/4).

The door leaf mounts are situated on the right and left-hand sides of the door leaf and are screwed to the hinge chains and the lowest lath of the door leaf (bottom lath). The hinge chains on both sides of the door system connect the bottom lath to the other laths. When the door leaf moves, the force is only applied to the bottom lath. All the other laths are fastened to the hinge chain and are moved at the same time without the effect of force.

### Manual emergency operation



*Fig. 8: Manual emergency operation*

In case of power failure, the door system can be opened or closed mechanically with the winch included in the scope of delivery. The control unit is in EMERGENCY STOP status during this operation.

## High-speed spiral door construction

### Vertical side frame with door leaf guide

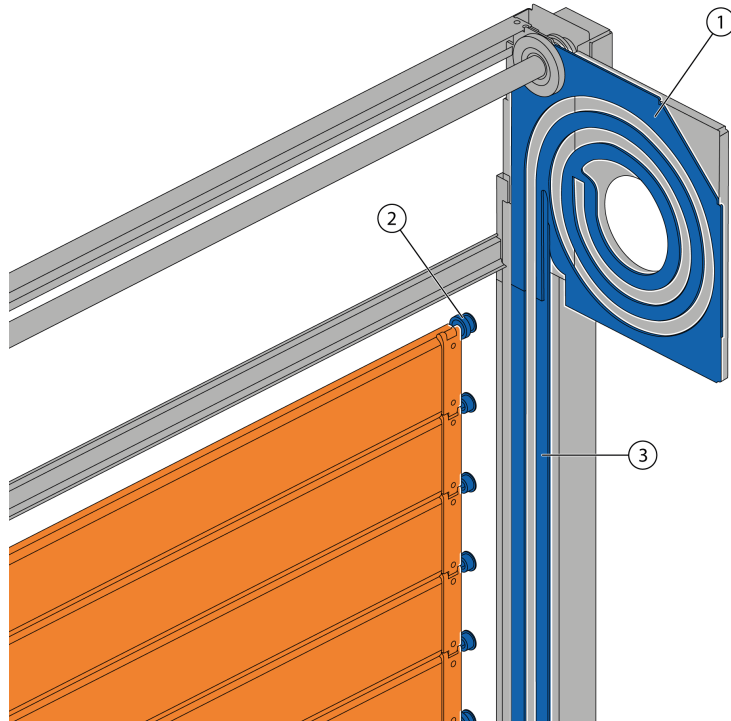

Fig. 9: Door leaf guide

The door leaf comprises laths that are connected by a hinge chain. Rollers (Fig. 9/2) are attached to the hinge chain. When the door system is opened and closed, the rollers are directed through the vertical (Fig. 9/3) and spiral-shaped (Fig. 9/1) door leaf guide. The rollers rolling along in the door leaf guide only generates very low noise. The roller friction also makes for minimum wear on the rollers, as no soiling is generated from abrasion. There is no wear on the door leaf itself. This gives the door system a long service life.

The vertical door leaf guides (Fig. 9/3) are made of bevelled sheet metal covers and are situated within the side frames. Each side frame is made up of one main bevelled sheet metal profile and one bevelled sheet metal cover profile.

**Resistance class 2 (WK2) as defined in DIN V ENV 1627:1999-04 and (RC2) as defined in DIN/TS 18194:2020**

Due to the drive system's design with chains (drive chain and door leaf chains) and a drive with worm gear, the door system 314 achieves resistance class 2 after each complete closing in the "door closed" position.

Resistance class 2 means that an opportunist with simple tools such as screwdrivers, pliers and wedges cannot break (open or penetrate) the door system within three minutes.

This applies to the following equipment:

- No single-walled EFA-CLEAR® transparent laths
- No EFA-VENT® ventilation laths

- One double-walled EFA-CLEAR® transparent lath with SAN filling – One EFA-THERM® lath – One double-walled EFA-CLEAR® transparent lath with SAN filling
  - Two double-walled EFA-CLEAR® transparent laths with SAN filling must not be arranged directly above one another. There must be at least one EFA-THERM® lath in between.
- Max. four double-walled EFA-CLEAR® transparent laths with PC-H filling – One EFA-THERM® lath – max. four double-walled EFA-CLEAR® transparent laths with PC-H filling – etc.
  - No more than four double-walled EFA-CLEAR® transparent laths with PC-H filling must arranged directly above one another. There must be at least one EFA-THERM® lath in between.
- The use of a side frame extension must be examined on a case-by-case basis.
- The use of screw-through assembly must be examined on a case-by-case basis.

The door system type is listed in what is known as the “KPK list” (KPK: Kommission Polizeiliche Kriminalprävention; Commission for Crime Prevention), which can be accessed online via the Bavarian State Criminal Police Office. This KPK list records tested and certified burglar-resistant products and is updated twice a year as scheduled.



Fig. 10: Seal manufacturer directories

### Door leaf

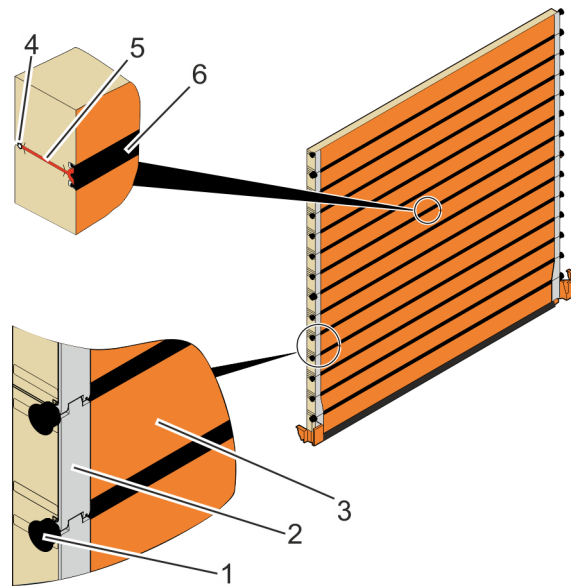

*Fig. 11: Door leaf*

The door leaf is assembled from laths (Fig. 11/3) that are kept at the correct spacing by hinge chains (Fig. 11/2) attached at the sides. This spacing prevents contact between the laths. They are thus free from wear. The forces for opening and closing the door system are transmitted via the hinges.

Ball bearing-mounted rollers (Fig. 11/1) keep the door leaf firmly in the guides in the horizontal direction. The laths are connected to one another by rubber hinges (Fig. 11/6) and O-profile seals (Fig. 11/4). An air cushion (Fig. 11/5) is created between the laths. It provides similarly effective insulation as that of the laths.

This homogeneous door leaf construction ensures the very good running performance, the high running speed and the excellent U-value.

The door leaf is 40 mm thick.

## Structure of the laths

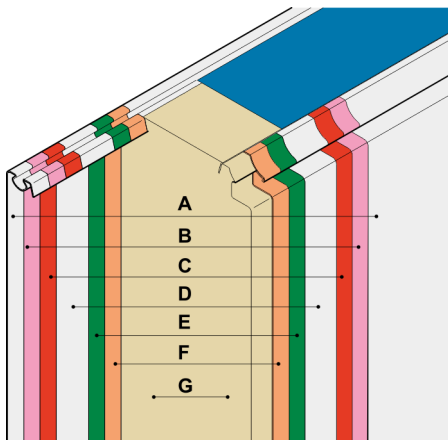

Fig. 12: Structure of the EFA-THERM<sup>®</sup> lath

The EFA-THERM<sup>®</sup> laths are structured with the following layers:

- A Top coat
- B Primer
- C Zinc coat 150 g/m<sup>2</sup>
- D Sheet metal (made of steel coil)
- E Zinc coat 150 g/m<sup>2</sup>
- F Adhesive
- G PU hard foam, 42 kg/m<sup>3</sup>, CFC and HCFC free

## EFA-THERM<sup>®</sup> lath

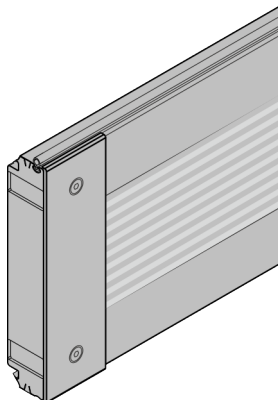

Fig. 13: EFA-THERM<sup>®</sup> lath

The thermally insulated EFA-THERM<sup>®</sup> lath comprises galvanised steel plates with CFC-free PU foam insulation.

|            |  |
|------------|--|
| Dimensions | 40 × 222 mm  |
| Material   | Steel plate 0.4 mm                                 |
| Finish     | 2 coats of paint                                   |
| Colour     | White aluminium, similar to RAL 9006 or RAL 9007   |
| Optional   | Wet lath coating<br>Colours in compliance with SAP |

## High-speed spiral door construction

### EFA-CLEAR® transparent lath, double-walled (optional)

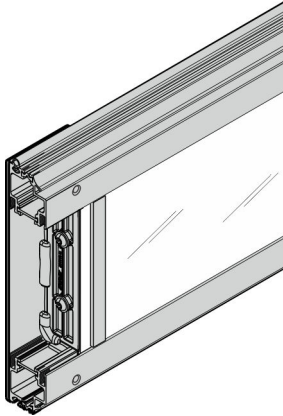

Fig. 14: Transparent lath (double-walled)

The double-walled, thermally insulated transparent laths are each comprised of two plastic panes which are pressed at intervals into aluminium profiles between the panes.

|            |  |
|------------|--|
| Dimensions | 40 × 222 mm  |
|            | Height of the viewing area: approx. 135 mm                           |
| Finish     | Anodised E6/EV1  |
| Glazing    | SAN panes  |
|            | Hard polycarbonate panes (scratch resistant)                         |
|            | SAN panes with a frosted glass finish and 75% translucency           |
| Optional   | Wet coating for aluminium profiles<br>Colours in compliance with SAP |

### EFA-CLEAR® transparent lath, single-walled (optional)

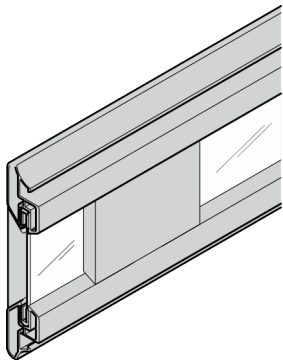
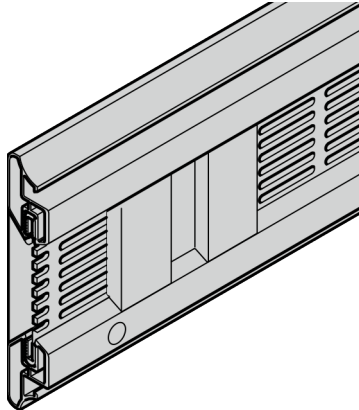

Fig. 15: Transparent lath (single-walled)

The transparent laths comprise transparent plastic panes pressed into the aluminium profiles.

|            |  |
|------------|--|
| Dimensions | 40 × 222 mm  |
|            | Height of the viewing area: approx. 155 mm                           |
| Finish     | Anodised E6/EV1  |
| Glazing    | SAN panes  |
|            | Hard polycarbonate panes (scratch resistant)                         |
|            | SAN panes with a frosted glass finish and 75% translucency           |
| Optional   | Wet coating for aluminium profiles<br>Colours in compliance with SAP |

### EFA-VENT® ventilation lath (optional)



The ventilation laths are made up of aluminium metal sheets with elongated holes (50 × 6 mm) which are pressed into the aluminium profiles.

|                                      |   |
|--------------------------------------|---|
| Dimensions                           | 40 × 222 mm   |
| Finish                               | Anodised E6/EV1   |
| Vent cross-section in m <sup>2</sup> | LA = (B - 0.105) × 0.066 × number of laths<br>B = door system width in metres               |
| Optional                             | Wet coating for aluminium profiles and ventilation sheets<br>Colours in compliance with SAP |

Fig. 16: Ventilation lath

### EFA-THERM® lath variants

| Door system type 314 |          |                |                        |           |
|----------------------|----------|----------------|------------------------|-----------|
|                      |          | Surface/colour |                        |           |
| Sheet thickness      | Material | Coil colour    | RAL paint              |           |
| 0.4 mm               | Steel    | 9006           | -                      | Available |
| 0.4 mm               | Steel    | 9007           | -                      | Available |
| 0.4 mm               | Steel    | -              | In compliance with SAP | Available |

### LA1

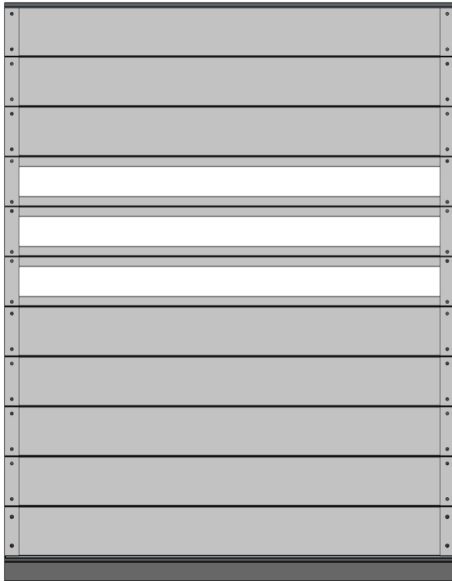

View from the outside

- EFA-THERM® lath, steel/aluminium sheet, surface similar to RAL 9006
- EFA-THERM® lath protective sheet (aluminium), surface E6/EV1 (natural anodised) and screws galvanised/stainless steel
- EFA-CLEAR® lath, single or double glazing or ventilation lath (aluminium), surface E6/EV1 (natural anodised) and screws galvanised/stainless steel

Fig. 17: Door leaf design LA1

### LA2

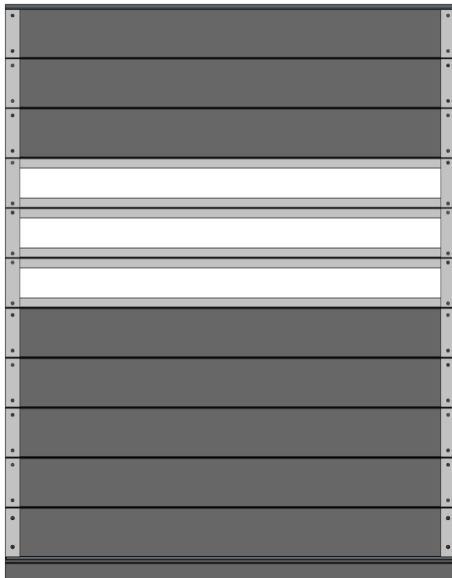

View from the outside

- EFA-THERM® lath, steel sheet, surface similar to RAL 9007
- EFA-THERM® lath protective sheet (aluminium), surface E6/EV1 (natural anodised) and screws galvanised/stainless steel
- EFA-CLEAR® lath, single or double glazing or ventilation lath (aluminium), surface E6/EV1 (natural anodised) and screws galvanised/stainless steel

Fig. 18: Door leaf design LA2

### LA3

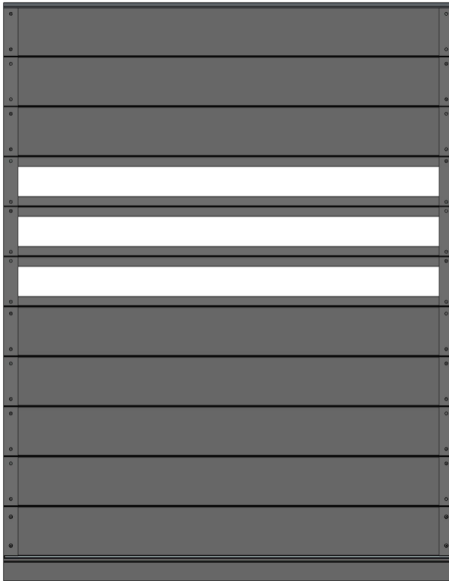

View from the outside

- EFA-THERM® lath, steel sheet, surface similar to RAL 9007
- EFA-THERM® lath protective sheet (aluminium) and screws with wet varnish similar to RAL 9007
- EFA-CLEAR® lath, single or double glazing or ventilation lath (aluminium) with wet varnish similar to RAL 9007

Fig. 19: Door leaf design LA3

### LA4



View from the outside

- EFA-THERM® lath, steel sheet, surface similar to RAL 9007
- EFA-THERM® lath protective sheet (aluminium) and screws with wet varnish similar to RAL 9007
- EFA-CLEAR® lath, single or double glazing or ventilation lath (aluminium), surface E6/EV1 (natural anodised) and screws galvanised/stainless steel

Fig. 20: Door leaf design LA4

### LA1 (interior)

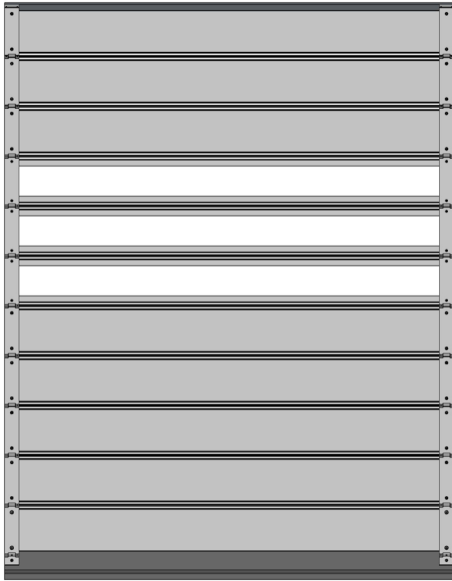

View from the inside

- EFA-THERM® lath, steel/aluminium sheet, surface similar to RAL 9006
- Hinge chain (aluminium), surface E6/EV1 (natural anodised) and screws galvanised/stainless steel
- EFA-CLEAR® lath, single or double glazing or ventilation lath (aluminium), surface E6/EV1 (natural anodised) and screws galvanised/stainless steel

Fig. 21: Door leaf design LA1, interior

### LA2 and LA4 (interior)

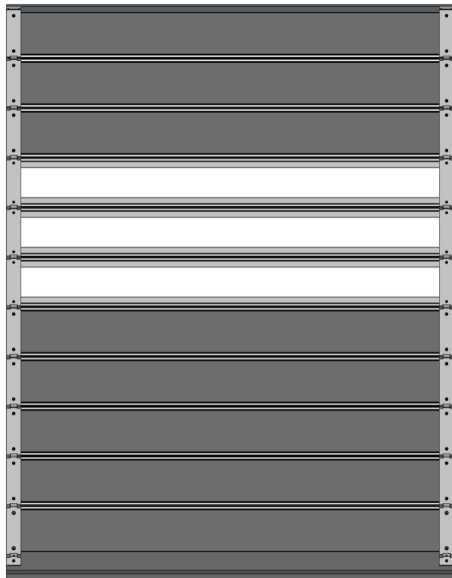

View from the outside

- EFA-THERM® lath, steel/aluminium sheet, surface similar to RAL 9007
- Hinge chain (aluminium), surface E6/EV1 (natural anodised) and screws galvanised/stainless steel
- EFA-CLEAR® lath, single or double glazing or ventilation lath (aluminium), surface E6/EV1 (natural anodised) and screws galvanised/stainless steel

Fig. 22: Door leaf design LA2 and LA4, interior

### LA3 (interior)

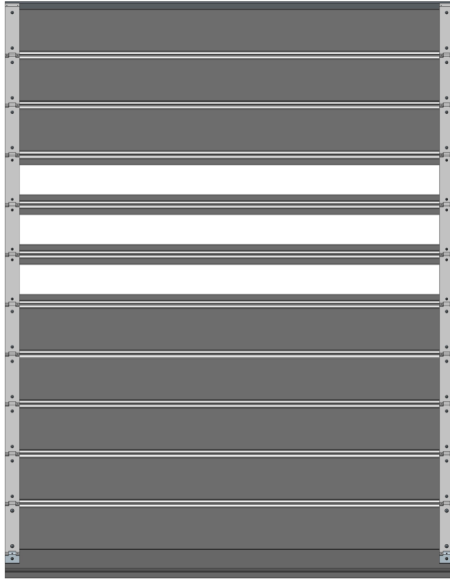

View from the outside

- EFA-THERM® lath, steel/aluminium sheet, surface similar to RAL 9007
- Hinge chain (aluminium), surface E6/EV1 (natural anodised) and screws galvanised/stainless steel
- EFA-CLEAR® lath, single or double glazing or ventilation lath (aluminium) with wet varnish similar to RAL 9007

*Fig. 23: Door leaf design LA3, interior*

### Seal

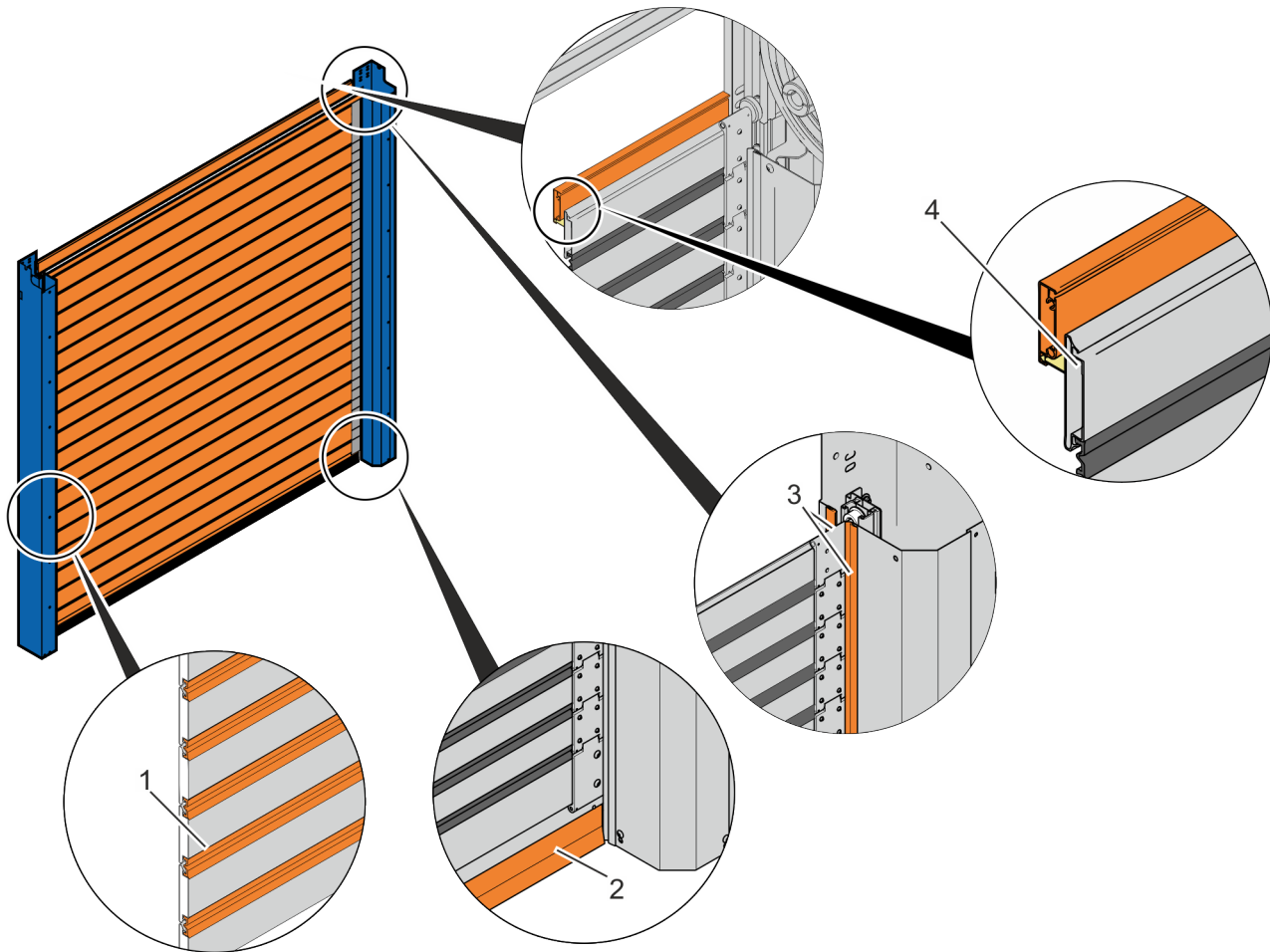

Fig. 24: Seal

The low-wear plastic door leaf seals (Fig. 24/3) provide the vertical sealing effect.

Rubber profiles (Fig. 24) are used for horizontal sealing, which protrude into the side frame on the left and right.

The laths are sealed off by rubber hinges and O-profile seals, one below the other (Fig. 24/1).

A sealing profile, mounted between the consoles or on the lintel, seals off the top of the door system. The top of the door system is also sealed by additional profiles with a rubber lip, which are fastened to the top lath. If the door system is closed, the rubber lip seals off the sealing profile by overlapping (Fig. 24/4).

## Drive

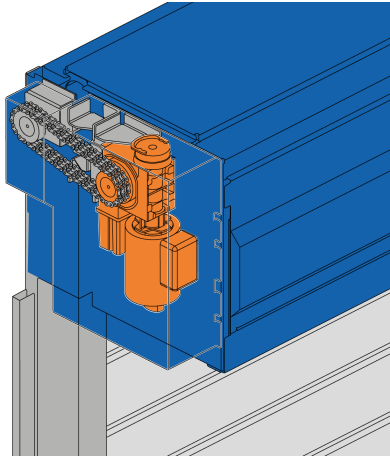

|                    |   |
|--------------------|---|
| Drive type         | Drive with worm gear and gear failure safeguard<br>(Worm gear, asynchronous AC motor) |
| Power classes      | 1.3 kW  |
| Protection type    | IP54  |
| Position detection | Absolute encoder.<br>Thus no reference run is required.                               |

Fig. 25: Drive

## Controls

| Door system type | EFA-TRONIC® | EFA-TRONIC® Professional | Standard installation position      |
|------------------|-------------|--------------------------|-------------------------------------|
| 314              | ●           | ○                        | On the side, next to the side frame |

- Standard
- optional

## High-speed spiral door construction

### EFA-TRONIC® control

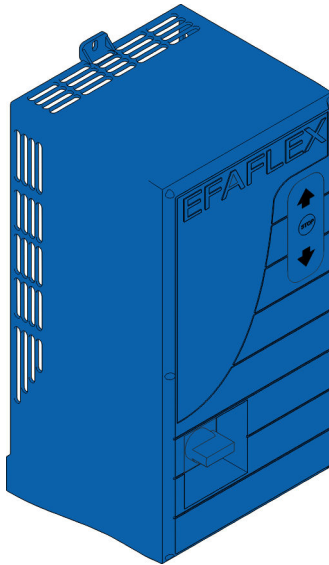

Fig. 26: EFA-TRONIC® control

|   |   |
|---|---|
| Control   | EFA-TRONIC® with frequency converter  |
| Size (W × H × D)  | 210 × 400 (565)* × 200 mm<br>(* incl. cable cover)                                    |
| Housing   | Polycarbonate housing   |
| Protection type   | IP65  |
| Sight glass for display screen                            | Display of status messages and fault messages   |
| Operating controls  | Operating panel for operation and parametrisation of the door system<br>Master switch |
| Supply voltage  | 3~L/N/PE 400 V ± 10 %   |
| Frequency   | 50 – 60 Hz  |
| Supply cable  | Fuse protection of 16 A to be provided by the user (K characteristic)                 |
| With residual-current circuit breaker (RCCD) as necessary | 300 mA as per DIN VDE 0100-530 (sensitive to universal current)                       |

### EFA-TRONIC® Professional

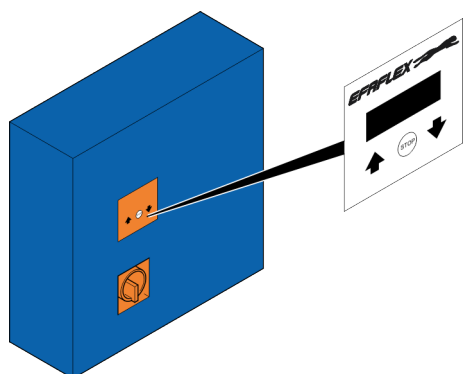
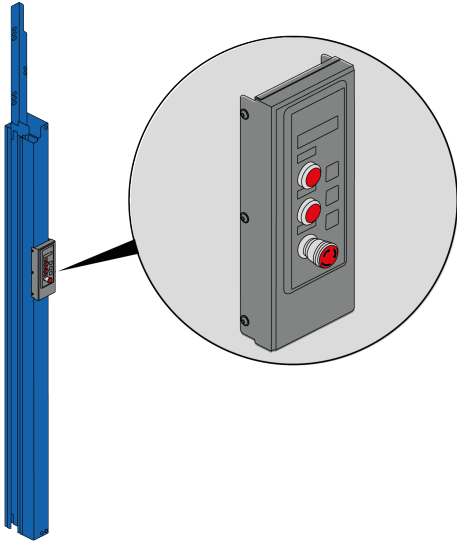

Fig. 27: EFA-TRONIC® Professional

|  |   |
|--|---|
| Control unit                                     | EFA-TRONIC® Professional with frequency converter   |
| Size (W × H × D)                                 | 380 × 380 × 210 mm  |
| Housing  | Steel, colour RAL 7035<br>Optionally:<br>■ Painted RAL, colours in compliance with SAP<br>■ V2A |
| Protection type                                  | IP54  |
| Viewing window for display                       | Display of status messages and fault messages   |
| Operating controls                               | Operating panel for operation and parametrisation of the door system<br>Master switch           |
| Supply voltage                                   | 3~L/N/PE 400 V ± 10 %   |
| Frequency  | 50 – 60 Hz  |
| Supply cable                                     | Fuse protection of 16 A to be provided on-site (K characteristic)                               |
| With residual current device (RCCD) as necessary | 300 mA in compliance with DIN VDE 0100-530 (sensitive to universal current)                     |

### EFA-HDI operating unit



An option to mount an additional operating unit on the side frame (on the drive side, Fig. 28) is available as an enhancement of the EFA-TRONIC®. It is equipped with a display screen and offers full access to all parameters and all basic functions.

*Fig. 28: EFA-HDI operating unit on the side frame*

### EFA-HDI operating unit

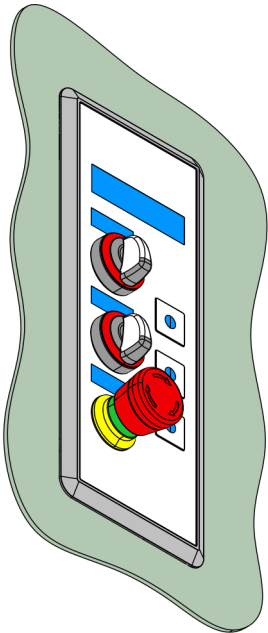

As an enhancement of the EFA-TRONIC® Professional, an option to mount an additional operating unit on the wall is available. It is equipped with a display screen and offers full access to all parameters and all basic functions.

*Fig. 29: EFA-HDI operating unit*

## 4 Door safety

### Available door safety

| Door system type | Safety edge and light barrier | Door light grid |
|------------------|-------------------------------|-----------------|
| 314              | •                             | -               |

- Standard

-not available for delivery

The main closing edge is secured by a combination of a safety edge and a light barrier (C device plus D device). This achieves the minimum protection level specified by EN 12453.

In addition, the owner and the manufacturer have to consult with each other in order to provide a safeguard for the approach area. This will be based on the owner's risk assessment.

### Safety edge and light barrier

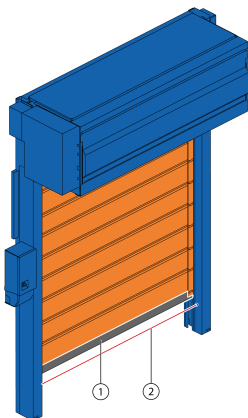

Fig. 30: Safety edge and light barrier

|   |                                |   |
|---|--------------------------------|---|
| 1 | Safeguard for the closing edge | Safety edge                                 |
| 2 | Light barrier (optional)       | Unidirectional light barriers (IP67) max. 2 |

If the safety edge comes into contact with a person during the closing procedure, the door leaf stops, the door system opens completely and closes automatically again once the "keep-open" time has elapsed.

The light barriers, which are installed in the side frames at the sides, are offset from the door closing level. The height of the light barriers is variable.

### 5 Equipment

#### Possible equipment<sup>1</sup>

- Galvanised basic door construction, 275 g/m<sup>2</sup>
- Basic door construction, galvanised (275 g/m<sup>2</sup>) with powder coated surface of externally visible areas in colours in compliance with SAP
  - Polyester based decorative powder coating
  - Coat thickness approx. 50 µm +/- 10 µm
  - Sheen level in compliance with DIN EN ISO 2813 (incidence angle 60°), 75 % ± 10 %
  - Smooth surface (no structure)
- Round spiral door leaf guide
- EFA-THERM<sup>®</sup> lath, 40 × 222 mm,
- Door leaf laths with painted finish as per RAL
  - Polyurethane-based decorative coating
  - Coat thickness approx. 50 µm +/- 10 µm
  - Sheen level in compliance with DIN EN ISO 2813 (incidence angle 60°), 30 % ± 10 %
  - Smooth surface (no structure)
- EFA-TRONIC<sup>®</sup> and EFA-TRONIC<sup>®</sup> Professional control unit
- Transparent lath with styrene-acrylonitrile (SAN) glazing
- Transparent lath with polycarbonate glazing
- Ventilation lath
- Emergency operation using the hand winch
- Command devices: Push-buttons, pull switches, key switches, etc.
- Control devices/safety: radar detector, IR (infrared presence sensor)
- Spiral case covers
- Safety edge with up to 2 light barriers
- EFA-HDI operating unit

<sup>1</sup> Depending on configuration

## 6 Packaging units

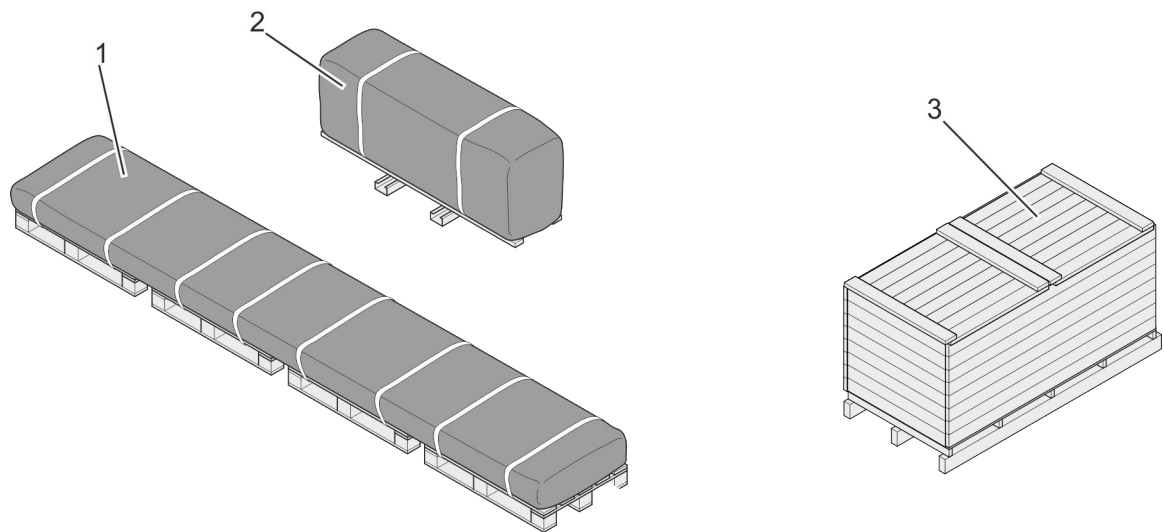

Fig. 31: Scope of delivery



*\*Fit-for-purpose packaging is packaging that ensures that the packaged goods reach the recipient without damage, taking into account the shipping loads, shipping route, shipping duration and transportation load profile.*

### Transport unit (example)

Transport unit 1: Side frame sections with covers, control unit, accessories

Transport unit 2: Spiral case with door leaf, drive

Transport unit 3: Wooden crate (optional)

### Number of transport units

The number of standard transport units depends on the selected number of door systems.

The door systems can also be delivered in a wooden crate. The number of wooden crates depends on the configuration of the door system types and the number of door systems.

Wood that complies with the IPPC standard is optionally available. For sea freight, the wooden crates are lined with film as protection against moisture.

## Packaging units

Packages fastened to pallets can be transported by forklift under the following conditions:

- The forklift must have the appropriate capacity for the weight of the packages.
- The package must be securely fastened to the pallet.
- The forklift driver must be authorised to drive industrial trucks with a driver's seat or driver's station in accordance with the local regulations.









EFAFLEX Tor- und Sicherheitssysteme

GmbH & Co. KG

Fliederstraße 14

84079 Bruckberg

Germany

Telephone: +49 8765 82-0

Fax: +49 8765 82-200

Email: [info@efaflex.com](mailto:info@efaflex.com)

Internet: [www.efaflex.com](http://www.efaflex.com)