



Technical product description
High-speed spiral door
Essential



For internal use only

This technical product description applies exclusively to
following door types:

EFA-SST® Essential, Type 276

EFAFLEX Tor- und Sicherheitssysteme GmbH & Co. KG

Fliederstraße 14

84079 Bruckberg

GERMANY

Telephone: +49 8765 82-0

Fax: +49 8765 82-200

email: info@efaflex.com

Internet: www.efaflex.com

Translation of the original

Version 00-EN

01.08.2014

© EFAFLEX Tor- und Sicherheitssysteme GmbH & Co. KG

Table of contents

1	Short description.....	4
2	Technical properties.....	6
3	High-speed spiral door construction.....	8
4	Door safety.....	21
5	Equipment.....	22
6	Packaging units.....	23

1 Short description

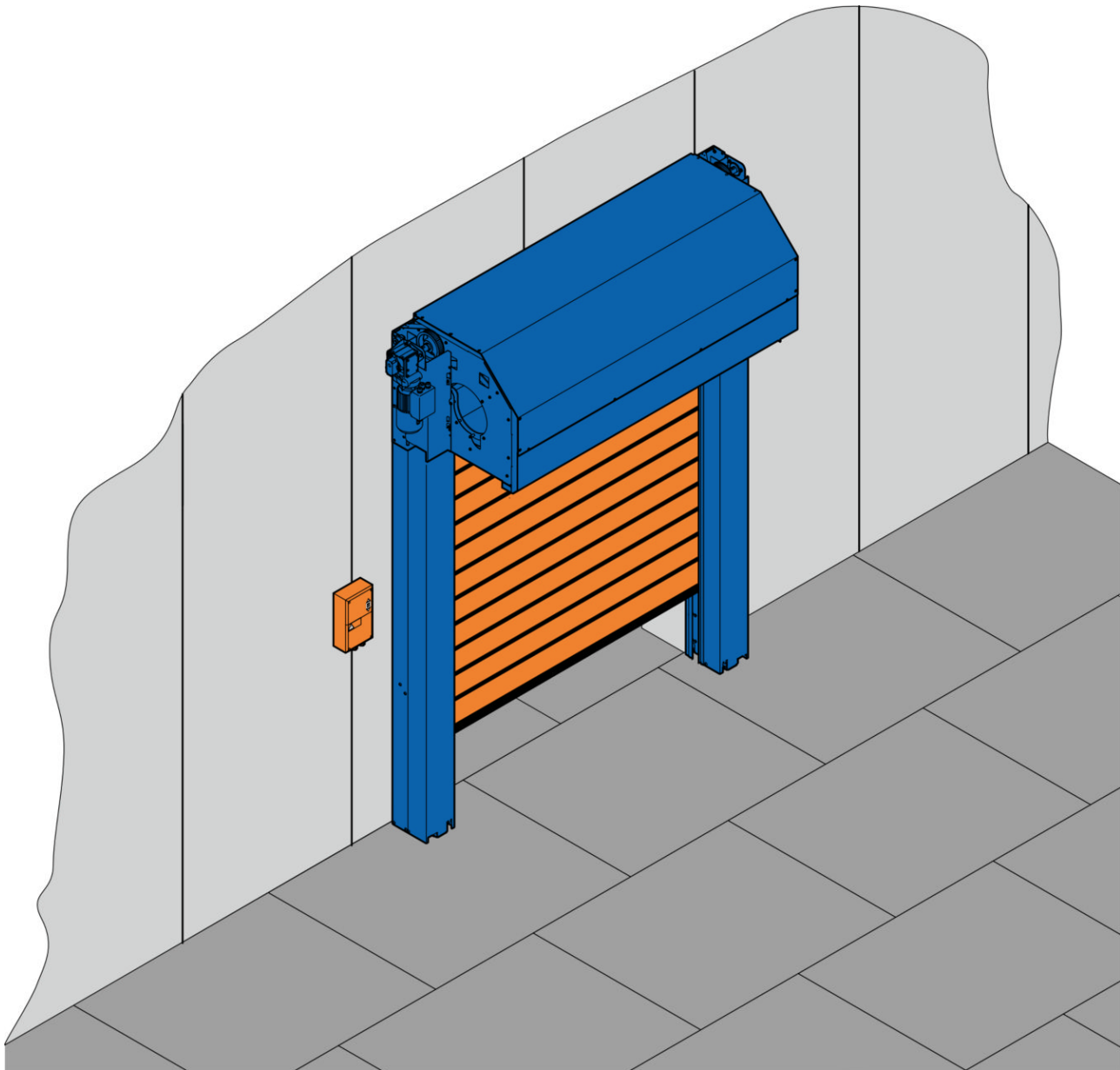

Fig. 1: High-speed spiral door

The EFA-SST® Essential high-speed spiral door is designed for low requirements of frequency of use and door leaf speed. The standard version and available options have been reduced to minimum requirements.

The door leaf and the technology used, such as toothed belts for transmission of force and the counterbalance system, are, to the largest possible extent, in line with the known and proven Efaflex spiral door standards. The door leaf is wound onto a round spiral.

The high-insulation door leaf is made of 40 mm thick EFA-THERM® sheet steel panels. Optional EFA-CLEAR® viewing panels with transparent SAN or PC hard panes can also be selected.

2 Technical properties

Use

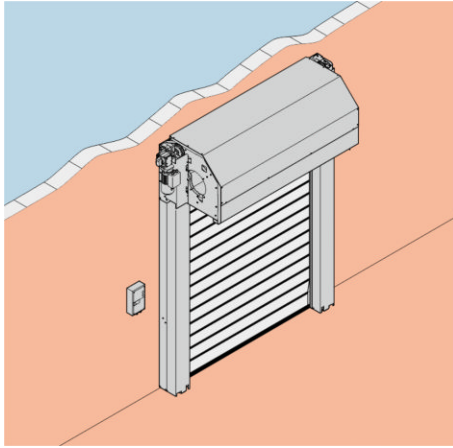

Fig. 2: Use

Use

- Industrial door
- Hall door
- Outdoor installation under a canopy provided by the owner (installation of the control unit: > +5 °C)

	Outdoor (-15 °C to +50 °C)
	Indoor (+5 °C to +50 °C)

Dimensions

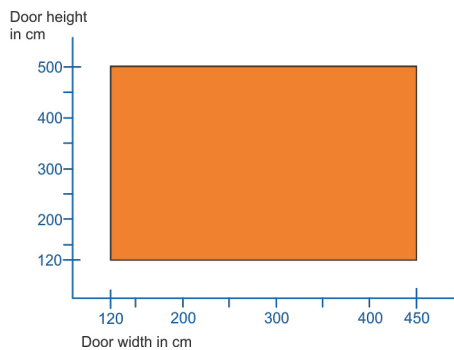

Fig. 3: Diagram of possible door heights and door widths

Data	Value	Unit
Door width	1200–4500	mm
Door height	1200–5000	mm

Speeds

Data	Value	Unit
Opening speed	approx. 0.5	m/s
Closing speed	approx. 0.5	m/s

Performance properties as per DIN EN 13241-1

Data	Door width/door size/ other indications	Value
Resistance to wind load as per DIN EN 12424	1200 mm ≤ B ≤ 3000 mm	Class 4
	3000 mm ≤ B ≤ 3500 mm	Class 3
	3500 mm ≤ B ≤ 4500 mm	Class 2
Resistance to water penetration as per DIN EN 12425	-	Class 2

Technical properties

Data	Door width/door size/ other indications	Value
Air permeability as per DIN EN 12426	-	Class 0
Airborne sound insulation as per EN ISO 717-1	With EFA-THERM® panel only	Rw = 24 dB
Thermal insulation as per DIN EN 12428	With EFA-THERM® panel only at 4500 mm x 5000 mm	U = 1.8 W/m²K

Fire performance as per DIN 4102

Data	Value
Material class	B2 normally inflammable

Applied safety standards

The following standard was applied for planning, engineering and production: DIN EN 13241-1 Doors – Product standard

Basic construction performance

Data	Value
Loadings per year	100 000
Service life	10 years

3 High-speed spiral door construction

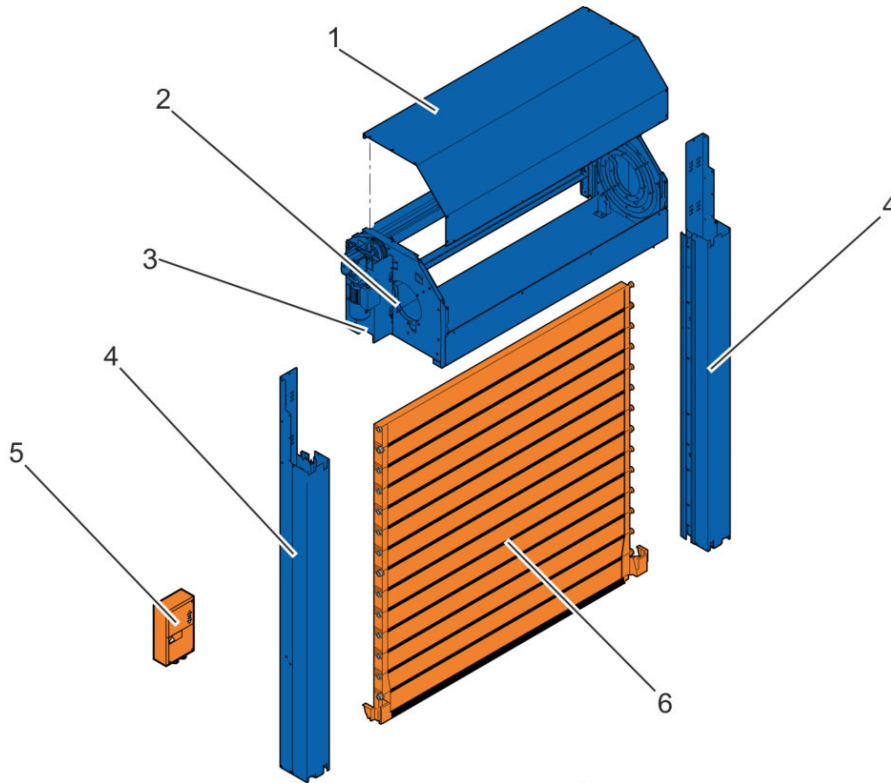
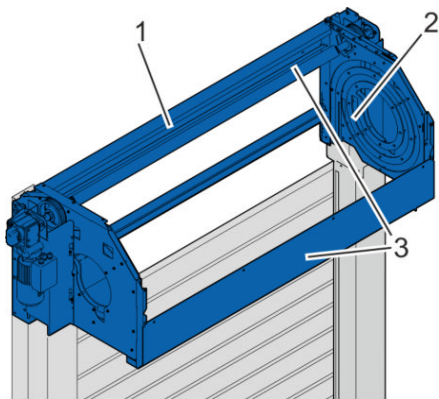

Fig. 4: Assemblies

1	Spiral console cover (optional)	↳ 'Spiral console cover (optional)' on page 9
2	Spiral console with main support, spiral guide, motor, drive shaft, bearing, reinforcement profiles	↳ 'Spiral console' on page 9 ↳ 'Drive' on page 19
3	Side frames casing, top (optional)	↳ 'Spiral console cover (optional)' on page 9
4	Side frames with vertical door leaf guide, door leaf belt and counter-balance	↳ 'Vertical side frame with door leaf guide' on page 14 ↳ 'Transmission of force' on page 10
5	Control unit	↳ 'EFA-FUZ2-G control unit' on page 19
6	Door leaf	↳ 'Door leaf' on page 15
	Panels	↳ 'Ventilation panel (optional)' on page 17
	Safety edge	↳ 'EFA-CLEAR® viewing panel, single-wall/double-wall (optional)' on page 16

Spiral console



The spiral console comprises:

- Synchronous shaft with bearing (item 1)
- bevelled, main supports with spiral guide (item /2) on both sides
- Sheet metal reinforcement profiles (item 3)

Fig. 5: Round spiral console

Spiral console cover (optional)

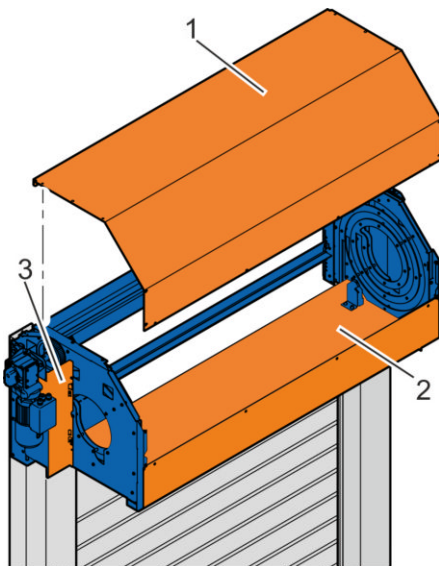

The cover of the spiral console is made up of sheet metal covers (Fig. 6).

The covers on the front and bottom (Fig. 6/1, 2) are only possible in combination. The top side frames casing (Fig. 6/3) is available for selection as an additional option.

The cover on the spiral console and the side frames as a protective guard is regulation for doors with a height of less than 2500 mm.

The cover reduces the clearance height by 40 mm.

Fig. 6: Spiral console cover with sheet metal profiles

High-speed spiral door construction

Transmission of force

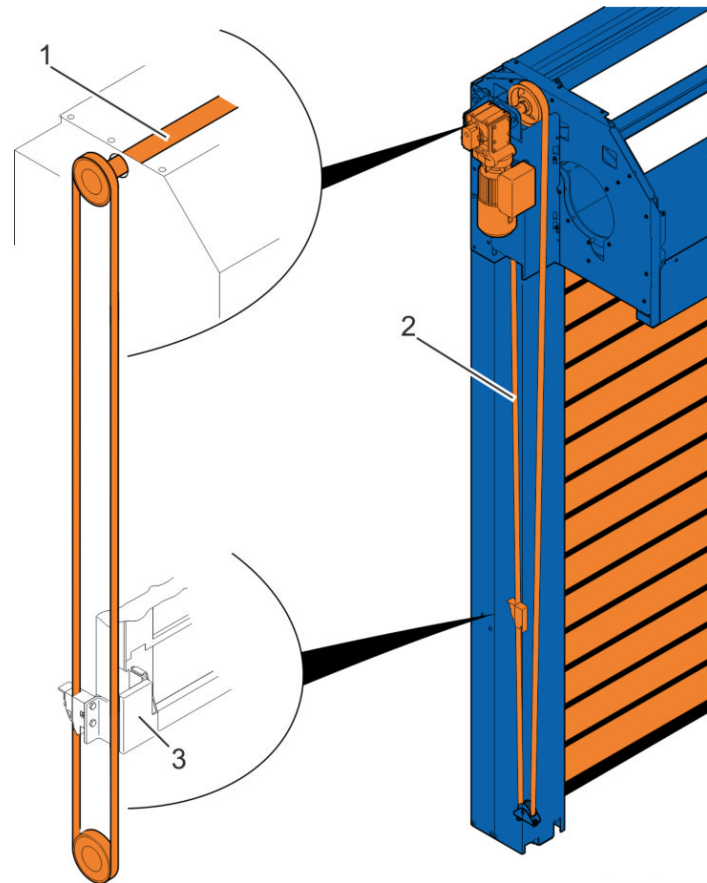

Fig. 7: Transmission of force

The transmission of force from the drive to the door leaf is performed by the synchronous shaft (item 1), the continuous toothed belt (item 2) and the door leaf mounts (item 3). Unlike a chain, the toothed belt runs very quietly.

The door leaf mounts are situated on the right and left-hand sides of the door leaf and are screwed to the hinge chains and the lowest panel of the door leaf (panel at bottom edge of door). The hinge chains on both sides of the door connect the panel at the bottom edge of the door to the other panels. When the door moves, the force is only applied to the panel at the bottom edge of the door. All the other panels are fastened to the hinge chain and are moved at the same time without the effect of force.

Counterbalance

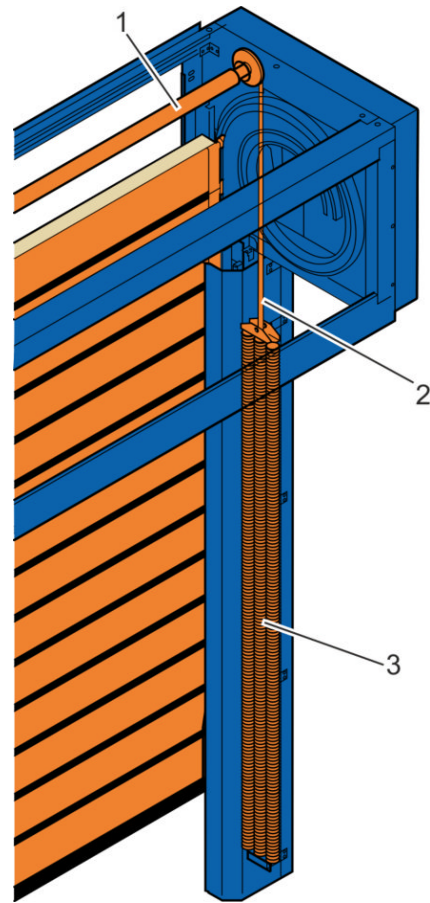

Fig. 8: Counterbalance

The door leaf counterbalance is implemented by a back pull mechanism: There are tension springs (Fig. 8/3) installed in the side frames. The tension springs are connected to the synchronous shaft (Fig. 8/1) by heavy load belts (Fig. 8/2). The tension springs are tensioned when the door is closed and relaxed when the door is open.

This way the door can also be opened by hand (without electrical power) in case of emergencies. In normal mode the motor is assisted by the force of the tension springs.

The spring tension is calculated for each individual door.

High-speed spiral door construction

Manual emergency operation

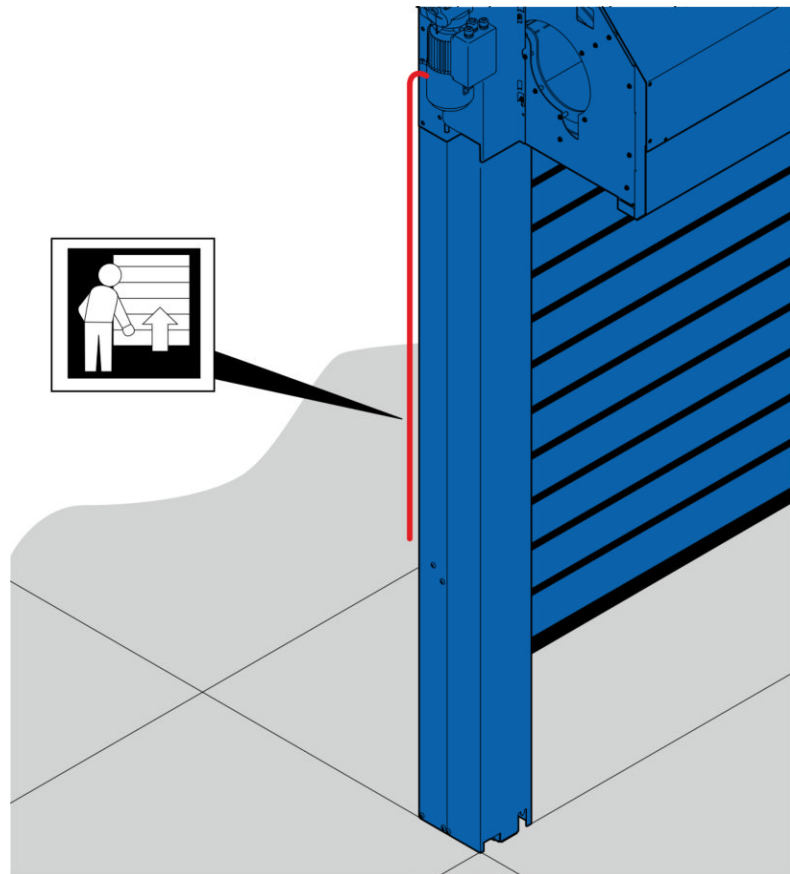

Fig. 9: Side frame rip cord

In emergency situations the drive brake can simply be triggered mechanically by pulling the hand rope, thus causing the door to open automatically due to the force of its counterbalance spring. The control unit is in emergency stop status during this operation.

Door locking mechanism (optional)

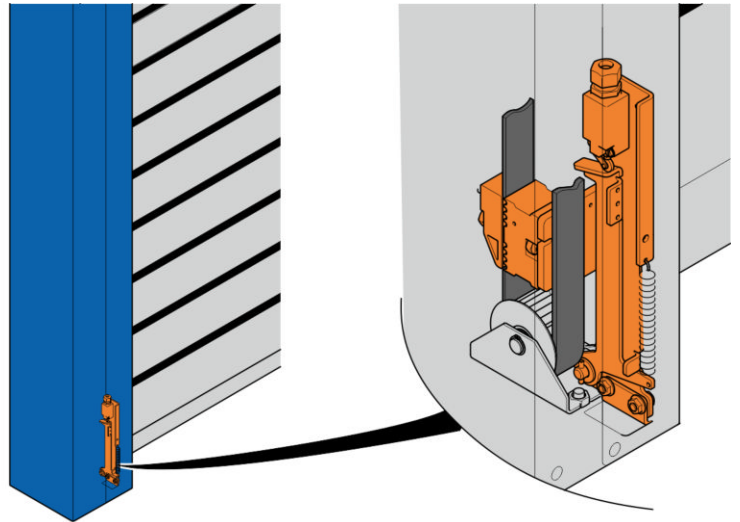

Fig. 10: Door locking mechanism

The mechanical locking mechanism is installed in the vertical side frame on the motor side. The locking mechanism handle keeps the door leaf closed so that it is safe from break-ins. The door locking mechanism is operated using a lever which is fitted to a separate console.

- The lever position depends on laying of Bowden cable
- Lever position up, optional locking version

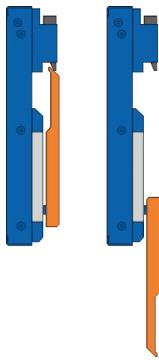

Fig. 11: Lever for door locking mechanism on separate console

High-speed spiral door construction

Vertical side frame with door leaf guide

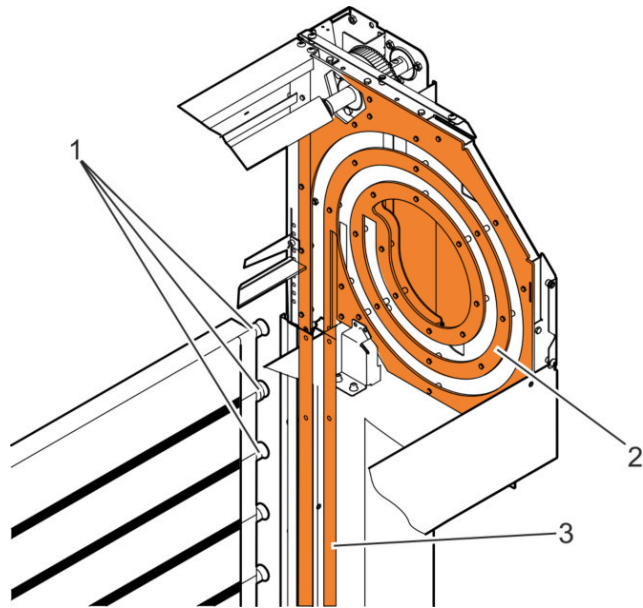

Fig. 12: Door leaf guide

The door leaf comprises panels which are connected by a hinge chain. Rollers (Fig. 12/1) are attached to the hinge chain. When the door is opened and closed, the rollers are directed through the vertical (Fig. 12/3) and spiral-shaped (Fig. 12/2) door leaf guide. The rolling of the rollers in the door leaf guide only generates very low noise. The roller friction also makes for minimum wear on the rollers as no soiling is generated from abrasion. There is no wear on the door leaf itself. This gives the door a long service life.

The vertical door leaf guides (Fig. 12/3) are made of bevelled sheet metal covers and are situated within the side frames. Each side frame is made up of one main bevelled sheet metal profile and one bevelled sheet metal cover profile.

Door leaf

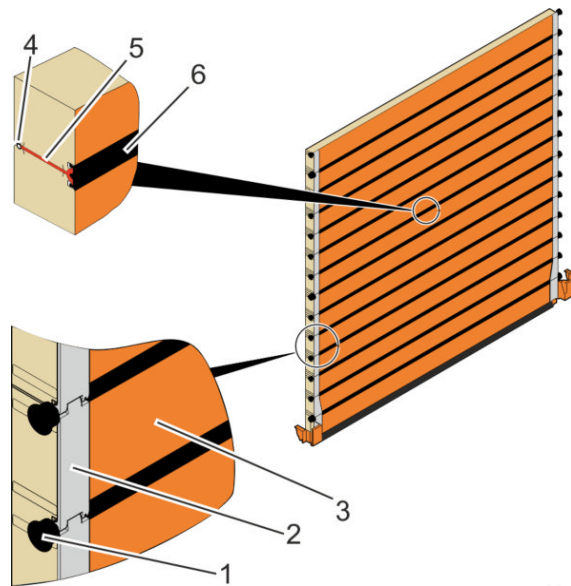

Fig. 13: Door leaf

The door leaf is assembled from panels (Fig. 13/3) which are held at the correct spacing by hinge chains (Fig. 13/2) attached at the sides. This spacing prevents contact between the panels. They are thus free from wear. The forces for opening and closing the door are transmitted via hinges.

Ball-bearing mounted rollers (Fig. 13/1) keep the door leaf firmly in the guides in the horizontal direction. The panels are connected to each other by rubber hinges (Fig. 13/6) and O-profile seals (Fig. 13/4). An air cushion (Fig. 13/5) is created between. It provides similarly effective insulation as that of the panels.

This homogeneous door leaf construction ensures the very good running performance, the high running speed and the excellent U-value.

The thickness of the door leaf is 40 mm.

Structure of the panels

The various panels are structured with the following layers:

High-speed spiral door construction

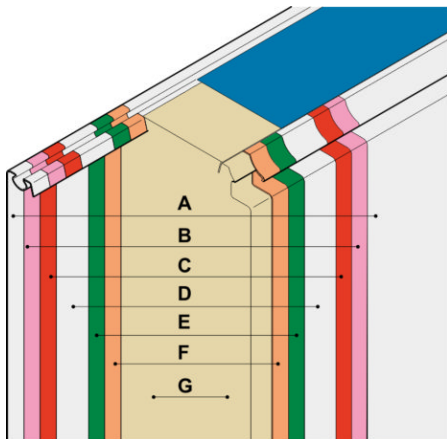

- A Pant top coat
- B Primer
- C Zinc coat 150 g/m²
- D Sheet metal
- E Zinc coat 150 g/m²
- F Adhesive
- G PU hard foam, 42 kg/m³, CFC and HCFC free

Fig. 14: Structure of the panels

EFA-THERM® panel

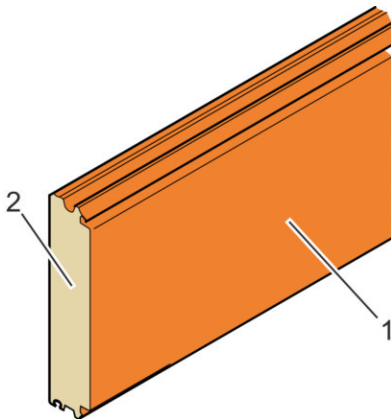

The thermally insulated EFA-THERM® panel comprises galvanised steel plates (Fig. 15/1) with CFC-free PU foam insulation (Fig. 15/2).

Dimensions	40 x 222 mm
Material	Steel plate 0.4 mm
Finish	2 coats of paint
Colour	White aluminium, similar to RAL 9006 (other colours available on request as an option)

Fig. 15: EFA-THERM® panel

EFA-CLEAR® viewing panel, single-wall/double-wall (optional)

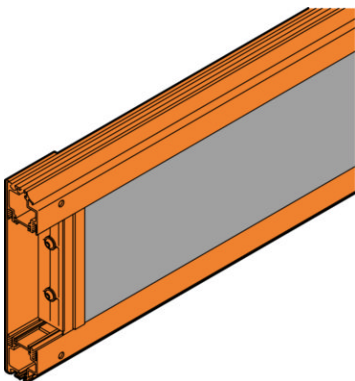

The double-walled thermally insulated viewing panels each comprise two plastic panes which are pressed at intervals into aluminium profiles between the panes.

Dimensions of the panel	40 x 222 mm
	Height of the viewing area: Approximately 135 mm
Finish	Anodised E6/EV1
Glazing	SAN panes
	Hard polycarbonate panes (scratch resistant)
Optional	Powder coating for aluminium profiles, colours as per RAL

Fig. 16: Viewing panel (double-wall)

High-speed spiral door construction

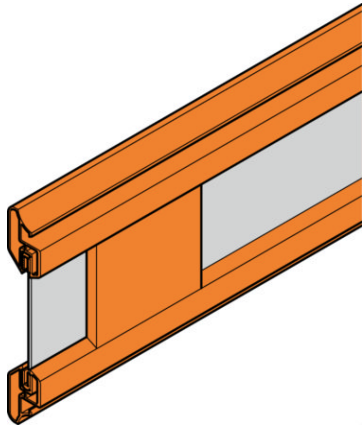

Fig. 17: Viewing panel (single-wall)

The viewing panels comprise transparent plastic panes pressed into the aluminium profiles.

Dimensions of the panel	40 x 222 mm Height of the viewing area: approximately 155 mm
Finish	Anodised E6/EV1
Glazing	SAN panes Hard polycarbonate panes (scratch resistant)
Optional	Powder coating for aluminium profiles, colours as per RAL

The number of viewing panels is limited.

Ventilation panel (optional)

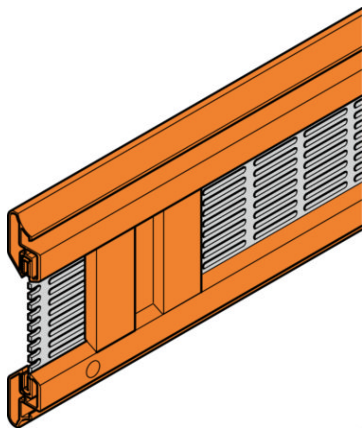

Fig. 18: Ventilation panel

The ventilation panels comprise aluminium metal sheet with elongated holes (50x6 mm) which are pressed into the aluminium frames.

Dimensions of the panel	40 x 222 mm
Finish	Anodised E6/EV1
Vent cross section in m ²	$NS = ((W - 0,105) * 0.066) * \text{number of panels}$ W = door width in metres
Optional	Powder coating for aluminium profiles and ventilation sheets, colours as per RAL

Seal

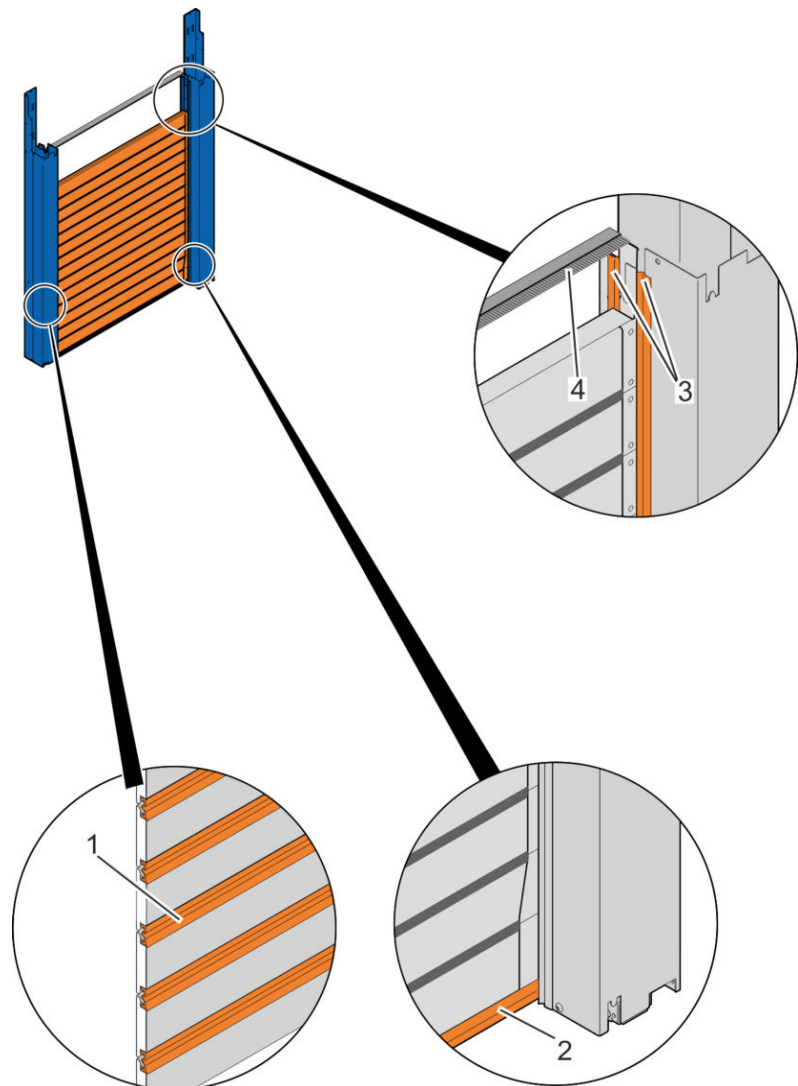

Fig. 19: Seal

The low-wear plastic door leaf seals (Fig. 19/3) provide the vertical sealing effect. The rubber profiles perform this function in the horizontal direction (Fig. 19/2). The panels are sealed off by rubber hinges one below the other (Fig. 19/1).

A horizontal brush (Fig. 19/4) provides the seal between the lintel, door leaf and side frames.

Drive

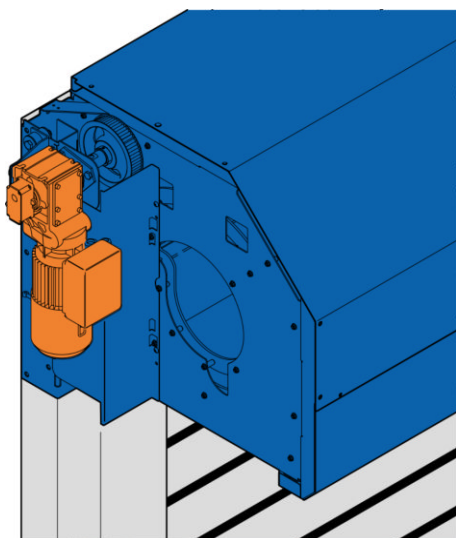

Fig. 20: Drive

Drive type	Direct mount drive (Spur gear asynchronous AC motor)
Power classes	0.55 kW / 100 Hz
Protection type	IP 54
Position detection	Incremental encoder

EFA-FU22-G control unit

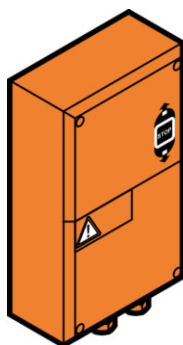

Fig. 21: Control unit

Control unit	FU22-G with frequency converter
Size	180 × 320 × 93 mm
Housing	Polycarbonate housing
Protection type	IP54
Viewing window for display screen	through housing
Operating control	OPEN-STOP-CLOSE (control cabinet front)
Supply voltage	230 VAC +/- 10 %
Frequency	50–60 Hz
Supply cable	Fuse protection of 16 A to be provided by the user (K characteristic)
With residual-current circuit breaker (RCCD) as necessary	300 mA as per DIN VDE 0100-530 (AC/DC sensitive)
Standard installation position	On the side of the side frame on the motor side at eye level

High-speed spiral door construction

mcp2 control unit

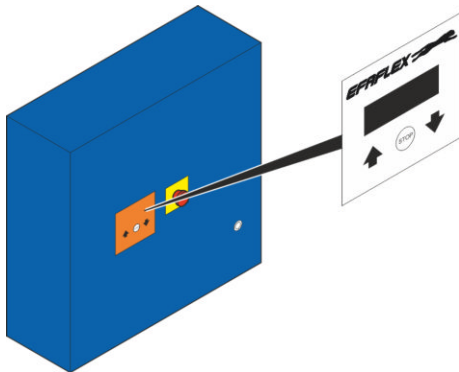

Fig. 22: Control unit

Control unit	mcp2 with frequency converter
Size	380x380x210 mm
Housing	Steel (V2A on request) Colour: RAL 7035
Protection type	IP65
Viewing window for display screen	
Operating control	OPEN-STOP-CLOSE (control cabinet front) Emergency stop master switch
Supply voltage	230 VAC +/- 10 %
Frequency	50–60 Hz
Supply cable	Fuse protection of 16 A to be provided by the user (K characteristic)
With residual-current circuit breaker (RCCD) as necessary	300 mA as per DIN VDE 0100-530 (AC/DC sensitive)
Standard installation position	On the side of the side frame, at a max. distance of 3 m from the door

4 Door safety

The main closing edge is secured by a combination of a safety strip and a light barrier (C device plus D device). This achieves the minimum protection level as per EN 12453.

In addition the owner and the manufacturer have to consult with each other in order to provide a safeguard for the approach area. This will be based on the owner's risk assessment.

Safety edge and light barrier

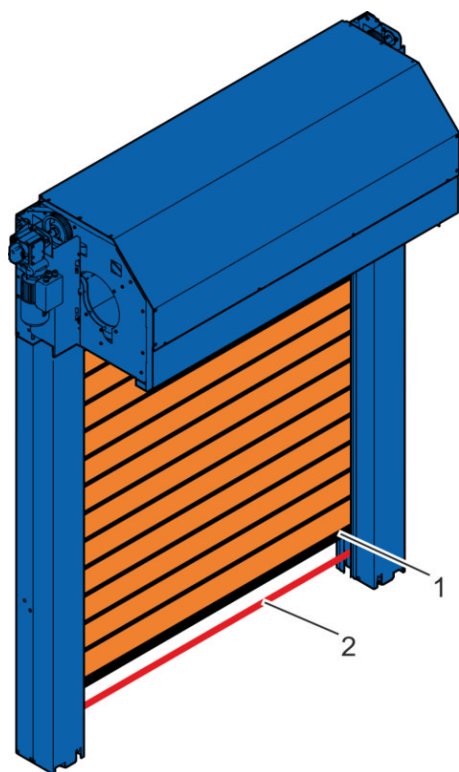

1	Closing edge safeguard	Safety edge
2	Light barrier (optional)	Unidirectional light barriers (IP 67) max. 2 x

If the safety edge comes into contact with an obstruction during the closing procedure, the system stops, opens completely and closes automatically again once the "keep-open" time has elapsed.

The light barriers which are installed in the side frames at the sides are positioned directly at the door closing level. The height of the light barriers is variable.

Fig. 23: Safety edge and light barrier

5 Equipment

Standard equipment

- Basic door construction, galvanised (275 g/m²)
- Round spiral door leaf guide
- EFA-Therm® panel, 222 mm x 40 mm
- FUZ2-G control unit
- Emergency operation using rip cord
- Safety contract edge with light barrier

Optional equipment (special equipment subject to surcharge) ¹

- Basic door construction, galvanised (275 g/m²), with powder-coated finish as per RAL
- Viewing panel with styrene-acrylonitrile glazing (SAN)
- Viewing panel with polycarbonate glazing
- Ventilation panel
- Door leaf panels with painted finish with RAL colour
- Command devices: Push-buttons, pull switches, key switches etc.
- Command devices/safety: Radar detector, IR (infrared presence sensor)
- Spiral console cover and side frames casing, top
- mcp2 control unit
- Locking mechanism on the console
- Up to 2 safety light barriers
- "Door closed" limit switch

¹ dependent on configuration

6 Packaging units

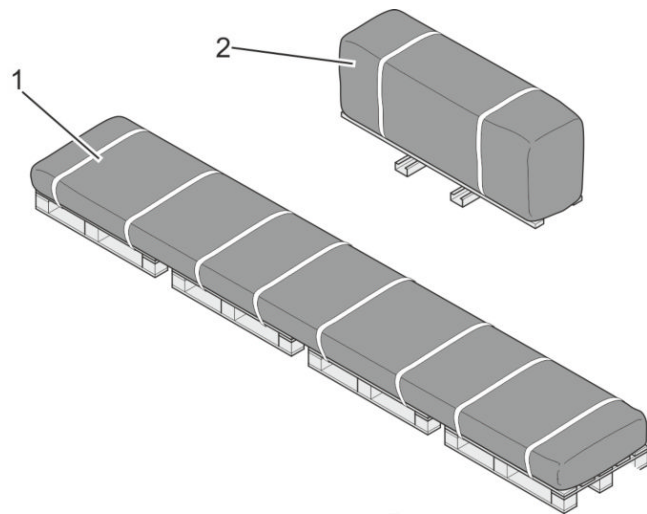

Fig. 24: Scope of delivery (standard transport units)

- 1 Transport unit 1 (example): Side frame sections with covers, control unit, accessories
- 2 Transport unit 2 (example): Spiral console with door leaf, drive

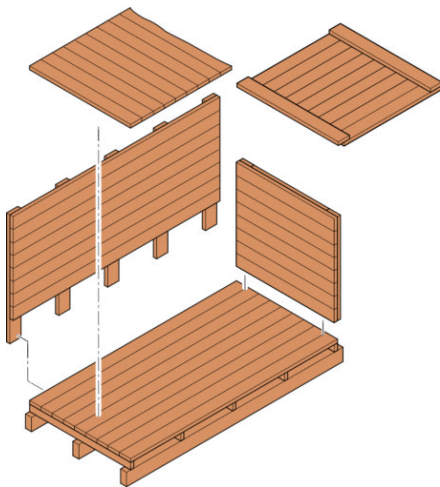

Fig. 25: Wooden crate

The number of transport units depends on the selected configuration.

The transport units can also be delivered in a wooden crate. The number of wooden crates depend on the dimensions of the standard transport units.

The wood for the wooden crates complies with the IPPC standard. The wooden crates are lined with film to protect them from moisture and are thus suitable for sea freight.

Packaging units

Packages which are fastened to pallets can be transported by fork lift under the following conditions:

- The fork lift must have the appropriate capacity for the weight of the packages.
- The package must be securely fastened to the pallet.
- The fork lift driver must be authorised to drive industrial trucks with a driver's seat or driver's station in accordance with the local regulations.

The transport units are not stackable.

EFAFLEX 
safe high-speed doors

EFAFLEX Tor- und Sicherheitssysteme GmbH
& Co. KG

Fliederstraße 14
84079 Bruckberg

GERMANY

Telephone: +49 8765 82-0

Fax: +49 8765 82-200

email: info@efaflex.com

Internet: www.efaflex.com