



Technical product description
High-speed spiral door
Premium ECO Basic



For internal use only

This technical product description
applies to the following door system types:

EFA-SST®-L Premium

EFA-SST®-S Premium

EFA-SST®-ÜS Premium

EFA-SST®-L ECO

EFA-SST®-S ECO

EFA-SST®-L Basic

EFA-SST®-XL Premium

EFA-SST®-XXL Premium

EFAFLEX Tor- und Sicherheitssysteme GmbH & Co. KG

Fliederstraße 14

84079 Bruckberg

GERMANY

Telephone: +49 8765 82-0

Fax: +49 8765 82-200

Email: info@efaflex.com

Internet: www.efaflex.com

Translation of the original

Version 10-EN

03.04.2023

© EFAFLEX Tor- und Sicherheitssysteme GmbH & Co. KG

Door system designations

Official designation of the door system	Spiral type	Designation of the door system in this product description
EFA-SST®-L Premium	Round spiral	260 R
	Oval spiral	260 O
EFA-SST®-S Premium	Round spiral	261 R
	Oval spiral	261 O
EFA-SST®-ÜS Premium	Round spiral	262 R
EFA-SST®-L ECO	Round spiral	263 R
	Oval spiral	263 O
	Low lintel	263 N
EFA-SST®-S ECO	Round spiral	264 R
	Oval spiral	264 O
	Low lintel	264 N
EFA-SST®-L Basic	Round spiral	265 R
	Oval spiral	265 O
	Low lintel	265 N
EFA-SST®-XL Premium	Round spiral	268 R
EFA-SST®-XXL Premium	Round spiral	305 R

Table of contents

1	Short description.....	5
2	Technical properties.....	6
3	Construction of the high-speed spiral door.....	17
4	Door safety.....	45
5	Equipment.....	47
6	Packaging units.....	49

1 Short description

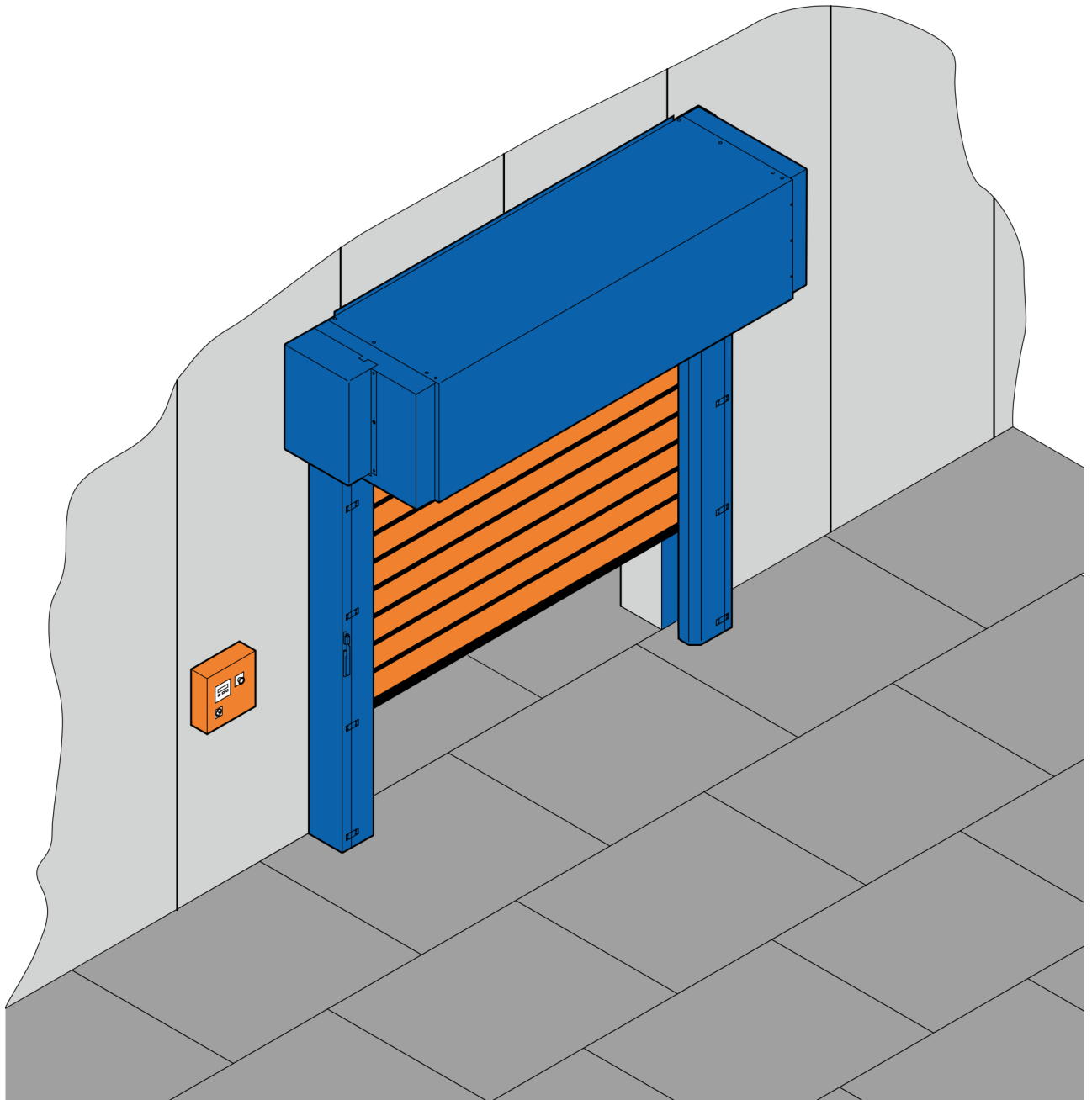

Fig. 1: High-speed spiral door

S series high-speed spiral doors are door systems designed for industrial and commercial purposes. The basic construction is based on tried and tested spiral door technology. The high-insulation door leaf is equipped with 40, 60, 80 and 100 mm thick EFA-THERM® and optional EFA-CLEAR® laths or EFA-VENT® ventilation laths.

2 Technical properties

Use

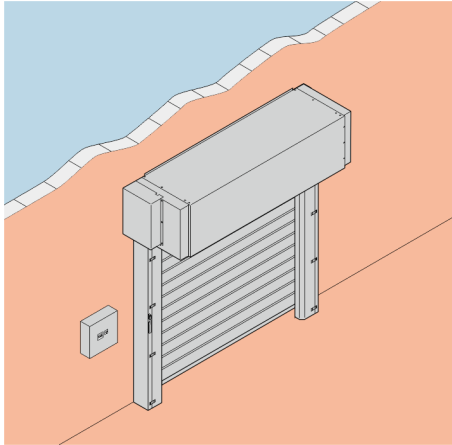

Fig. 2: Use

Use

- Industrial door
- Hall door
- Outdoor installation under a canopy provided by the owner possible



Outdoor (-15 °C to +50 °C)



Indoor (+5 °C to +50 °C)



The control cabinet must be installed in an ambient temperature of > +5 °C.

Dimensions “L”

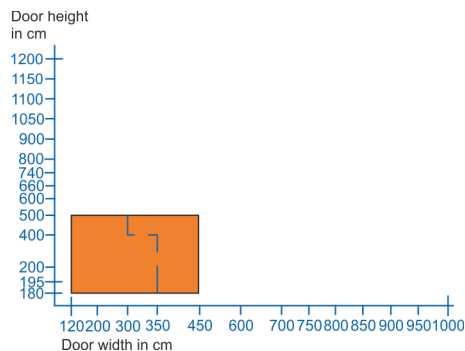

Fig. 3: Diagram of possible door system heights and door system widths

With regard to door system types 260, 263 and 265, there are two different structural designs of the side frame on the drive side, “L1” and “L2”. In this regard, structural design L2 is a side frame of large dimensions with space for springs in addition to those located in the opposite side frame.

L2 is absolutely essential for door system dimensions in the area to the right of the scaled line (Fig. 3). L1 is intended for door system dimensions in the area to the left of the scaled line (Fig. 3).

Door system heights and widths (inner clear height)

Door system type	Widths	Heights
L1: 260 O, 260 R	1200 – 3500 mm	1950 – 4000 mm
	1200 – 3000 mm	4000 – 5000 mm
L2: 260 O, 260 R	3500 – 4500 mm	1950 – 4000 mm
	3000 – 4500 mm	4000 – 5000 mm
L1: 263 R, 263 O	1200 – 3500 mm	1800 – 4000 mm
	1200 – 3000 mm	4000 – 5000 mm
L2: 263 R, 263 O	3500 – 4500 mm	1800 – 4000 mm
	3000 – 4500 mm	4000 – 5000 mm
263 N, 265 N	1200 – 4500 mm	1800 – 5000 mm
L1: 265 R, 265 O	1200 – 3500 mm	1800 – 5000 mm
L2: 265 R, 265 O	3500 – 4500 mm	1800 – 5000 mm

Dimensions “S”

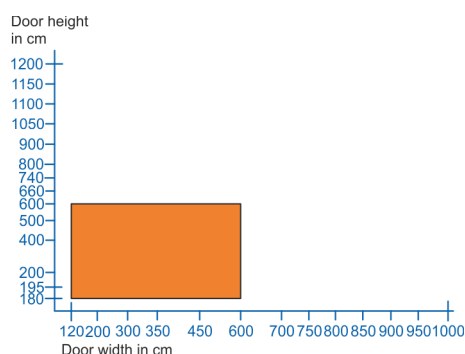

Fig. 4: Diagram of possible door system heights and door system widths

Door system heights and widths (inner clear height)

Door system type	Widths	Heights
261 R, 261 O	1200 – 6000 mm	1950 – 6000 mm
264 R, 264 O, 264 N	1200 – 6000 mm	1800 – 6000 mm

Technical properties

Dimensions "ÜS"

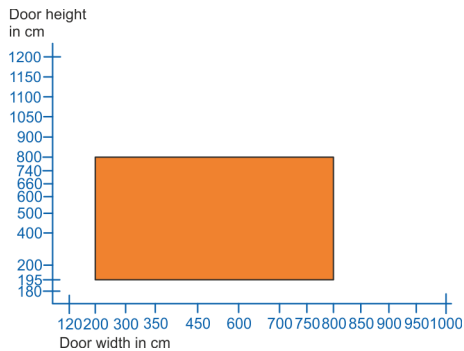

Fig. 5: Diagram of possible door system heights and door system widths

Door system heights and widths (inner clear height)

Door system type	Widths	Heights
262 R	2000 – 8000 mm	1950 – 8000 mm

"XL Premium" dimensions

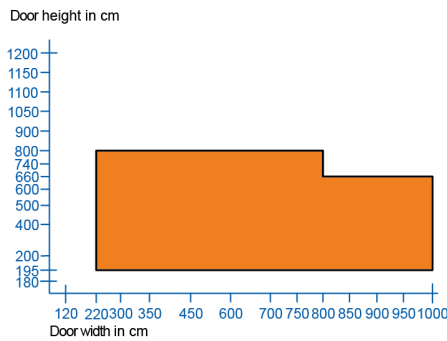

Fig. 6: Diagram of possible door system heights and widths

Door system heights and widths (inner clear height)

Door system type	Widths	Heights
268 R	2200 – 8000 mm	1950 – 8000 mm
	8001 mm – 10000 mm	1950 – 6600 mm

Dimensions "XXL Premium"

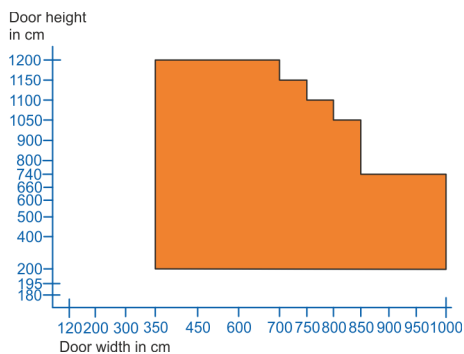

Fig. 7: Diagram of possible door system heights and door system widths

Door system heights and widths (inner clear height)

Door system type	Widths	Heights
305 R	3500 – 10000 mm	2000 – 12000 mm

Speeds

Door system type		Average speed (max. speed)		
		Opening speed	Closing speed with door light grid	Closing speed with safety edge and light barrier
Premium	260 R	2.0 m/s (2.5 m/s)	1 m/s	-
	260 O	1.5 m/s (2.0 m/s)	1 m/s	-
	261 R	1.2 m/s (1.5 m/s)	1 m/s	0.6 m/s
	261 O			
	262 R	1.0 m/s (1.2 m/s)	0.8 m/s	-
	268 R	0.8 m/s (1.0 m/s)	0.4 m/s	-
	305 R	0.5 m/s (0.5 m/s)	0.3 m/s	-
ECO	263 R	1.0 m/s (1.0 m/s)	0.6 m/s	0.6 m/s
	263 O			
	263 N			
	264 R	0.9 m/s (0.9 m/s)	0.6 m/s	0.6 m/s
	264 O			
	264 N			
Basic	265 R	0.5 m/s (0.5 m/s)	-	0.5 m/s
	265 O			
	265 N			

Speed dependent on the height of the door system

Performance properties as per DIN EN 13241

Door system type	Indication	Door system width/size/ other information	Value
260 R	Resistance to wind load as per DIN EN 12424	1200 mm ≤ B ≤ 3000 mm	Class 4
260 O		3000 mm < B ≤ 3500 mm	Class 3
263 R		3500 mm < B ≤ 4500 mm	Class 2
263 O	Resistance to water penetration as per DIN EN 12425	-	Class 3
265 R			
265 O	Air permeability as per DIN EN 12426	-	Class 3
	Airborne sound insulation as per DIN EN ISO 717-1	Only for EFA-THERM® lath	Rw = 24 dB
	Thermal insulation as per DIN EN 12428	Only for EFA-THERM® lath for 4500 × 5000 mm	U = 1.52 W/m²K

Technical properties

Door system type	Specification	Door system width/size/ other specifications	Value
263 N 265 N	Resistance to wind load in compliance with DIN EN 12424	1200 mm ≤ B ≤ 3000 mm	Class 4
		3000 mm ≤ B ≤ 3500 mm	Class 3
		3500 mm ≤ B ≤ 4500 mm	Class 2
	Resistance to water ingress in compliance with DIN EN 12425	-	npd
	Air permeability in compliance with DIN EN 12426	-	npd
	Airborne sound insulation in compliance with EN ISO 717-1	Depending on door leaf design and door leaf guide	Rw = 24 dB
Thermal insulation in compliance with DIN EN 12428	Depending on door leaf design and door leaf guide at 4500 × 5000 mm	U = 1.52 W/m ² K	

npd = no performance determined

Door system type	Indication	Door system width/size/ other information	Value
261 R 261 O 264 R 264 O	Resistance to wind load as per DIN EN 12424	1200 mm ≤ B ≤ 4000 mm	Class 4
		4000 mm < B ≤ 5500 mm	Class 3
		5500 mm < B ≤ 6000 mm	Class 2
	Resistance to water penetration as per DIN EN 12425	-	Class 3
	Air permeability as per DIN EN 12426	-	Class 3
	Airborne sound insulation as per DIN EN ISO 717-1	Only for EFA-THERM® lath	Rw = 25 dB
Thermal insulation as per DIN EN 12428	Only for EFA-THERM® lath for 6000 × 6000 mm	U = 0.91 W/m ² K	

Technical properties

Door system type	Indication	Door system width/size/ other information	Value
262 R	Resistance to wind load as per DIN EN 12424	$2000 \text{ mm} \leq B \leq 4500 \text{ mm}$	Class 4
		$4500 \text{ mm} < B \leq 6500 \text{ mm}$	Class 3
		$6500 \text{ mm} < B \leq 8000 \text{ mm}$	Class 2
	Resistance to water penetration as per DIN EN 12425	-	Class 3
	Air permeability as per DIN EN 12426	-	Class 3
	Airborne sound insulation as per DIN EN ISO 717-1	Only for EFA-THERM® lath	Rw = 26 dB
Thermal insulation as per DIN EN 12428	Only for EFA-THERM® lath for $8000 \times 8000 \text{ mm}$	U = 0.66 W/m ² K	

Door system type	Indication	Door system width/size/ other information	Value
264 N	Resistance to wind load as per DIN EN 12424	$1200 \text{ mm} \leq B \leq 4000 \text{ mm}$	Class 4
		$4000 \text{ mm} < B \leq 5500 \text{ mm}$	Class 3
		$5500 \text{ mm} < B \leq 6000 \text{ mm}$	Class 2
	Resistance to water penetration as per DIN EN 12425	-	npd
	Air permeability as per DIN EN 12426	-	npd
	Airborne sound insulation as per DIN EN ISO 717-1	dependent on door leaf design and door leaf guide	Rw = 25 dB
Thermal insulation as per DIN EN 12428	dependent on door leaf design and door leaf guide for $6000 \times 6000 \text{ mm}$	U = 0.91 W/m ² K	

npd = no performance determined

Technical properties

Door system type	Specification	Door system width/size/ other specifications	Value
268 R	Resistance to wind load in compliance with DIN EN 12424	B = 8000 mm	Class 2
		$1200 \text{ mm} \leq B \leq 4500 \text{ mm}$	Class 4
		$4500 \text{ mm} \leq B \leq 6500 \text{ mm}$	Class 3
		$6500 \text{ mm} \leq B \leq 8000 \text{ mm}$	Class 2
		B > 8000 mm	Class 0 (80 km/h)
	Resistance to water ingress in compliance with DIN EN 12425	-	Class 3
	Air permeability in compliance with DIN EN 12426	-	Class 3
	Airborne sound insulation in compliance with DIN EN ISO 717-1	-	Rw = 26 dB
Thermal insulation in compliance with DIN EN 12428	Only for EFA-THERM® lath at 10000 × 6600 mm	U = 0.66 W/m ² K	

Door system type	Indication	Door system width/size/ other information	Value				
			Steel plate 0.4 mm		Steel plate 0.6 mm		
305 R	Resistance to wind load as per DIN EN 12424	3500 mm ≤ B ≤ 10000 mm	-		Class 2	Fig. 8	↳ 'Designs of the EFA-THERM® lath' on page 29
		3500 mm ≤ B ≤ 9000 mm	-		Class 3	Fig. 9	
		3500 mm ≤ B ≤ 7500 mm	-		Class 4	Fig. 10	
		3500 mm ≤ B ≤ 8500 mm	Class 2	Fig. 8	↳ 'Designs of the EFA-THERM® lath' on page 29	-	
		3500 mm ≤ B ≤ 7000 mm	Class 3	Fig. 9		-	
		3500 mm ≤ B ≤ 5500 mm	Class 4	Fig. 10		-	
	Resistance to water penetration as per DIN EN 12425	-	Class 1		Class 1		
	Air permeability as per DIN EN 12426	-	Class 3		Class 3		
	Airborne sound insulation as per DIN EN ISO 717-1	-	Rw = 26 dB		Rw = 26 dB		
	Thermal insulation as per DIN EN 12428	7000 × 12000 mm*	U = 0.54 W/m²K		-		
10000 × 7400 mm*		-		U = 0.55 W/m²K			

* Only for EFA-Therm® lath

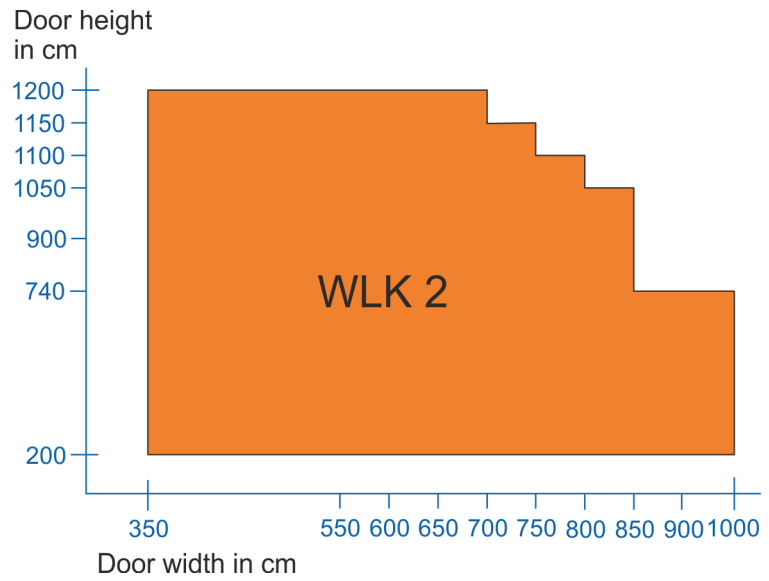

Fig. 8: Diagram, wind load class (WLC) 2 for door system type 305

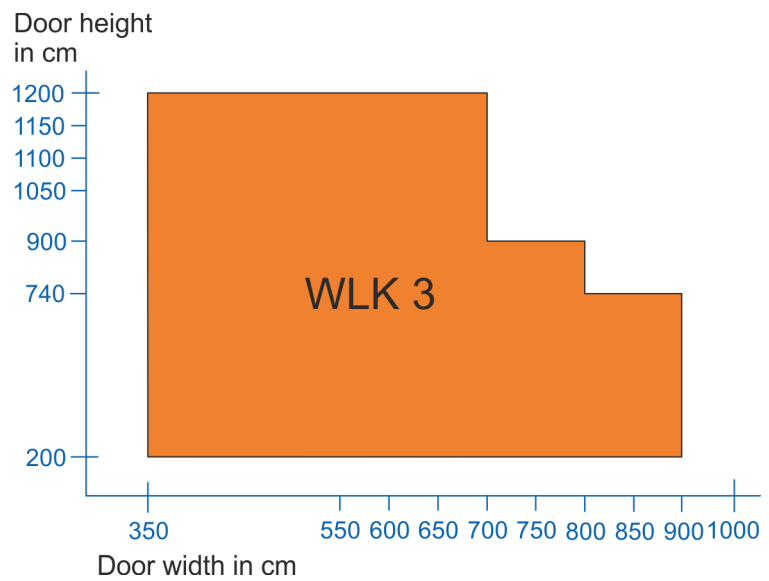

Fig. 9: Diagram, wind load class (WLC) 3 for door system type 305

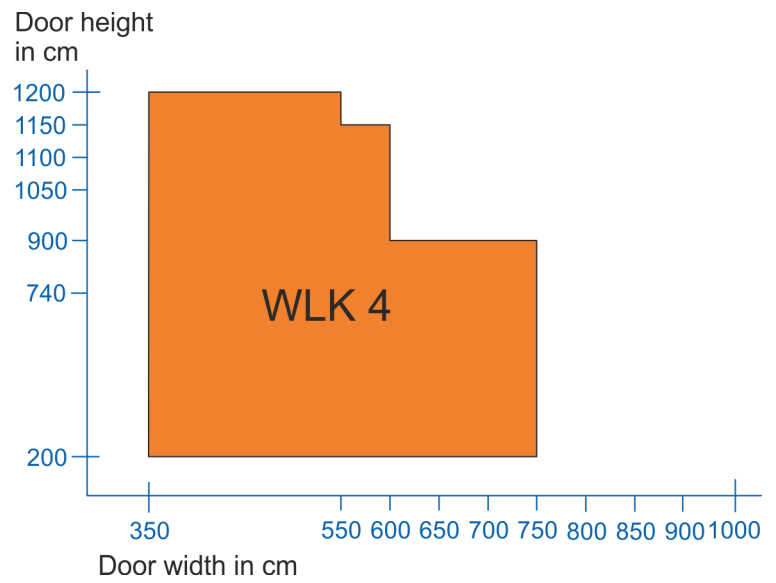

Fig. 10: Diagram, wind load class (WLC) 4 for door system type 305

Fire performance as per DIN 4102

Indication	Value
Material class	B2 normally inflammable

Technical properties

Applicable regulations, safety standards and directives

The following regulations, standards and directives were taken into account in planning, engineering and production:

Regulations

EUV 305/2011	REGULATION (EU) NO> 305/2011 OF THE EUROPEAN PARLIAMENT AND THE COUNCIL OF 9 March 2011 laying down harmonised conditions for the marketing of construction products and repealing Council Directive 89/106/EEC
--------------	---

Directives

2006/42/EC	DIRECTIVE 2006/42/EC OF THE EUROPEAN PARLIAMENT AND COUNCIL of 17 May 2006 on machinery, and amending Directive 95/16/EC
2014/30/EU	DIRECTIVE 2014/30/EU OF THE EUROPEAN PARLIAMENT AND COUNCIL of 26 February 2014 on harmonisation of the laws of the member states relating to electromagnetic compatibility
2014/53/EU	DIRECTIVE 2014/53/EU OF THE EUROPEAN PARLIAMENT AND OF THE COUNCIL of 16 April 2014 on the harmonisation of the laws of the Member States relating to the making available on the market of radio equipment and repealing Directive 1999/5/EC

Standards

DIN EN 13241	Doors – Product standard, performance characteristics
DIN EN ISO 13849-1	Safety of machinery – Safety-related parts of control systems – Part 1 General principles for design
DIN EN ISO 13849-2	Safety of machinery – Safety-related parts of control systems – Part 2 Validation
DIN EN ISO 12100	Safety of machinery – General principles for design – Risk assessment and risk reduction

Performance

Door system type	Load cycles per year	Life cycle
260 R; 260 O 261 R; 261 O	250,000	10 years
262 R 263 R; 263 O; 263 N 264 R; 264 O; 264 N	200,000	10 years
265 R; 265 O; 265 N	100,000	10 years
268 R	150,000	10 years
305 R	100,000	10 years

3 Construction of the high-speed spiral door

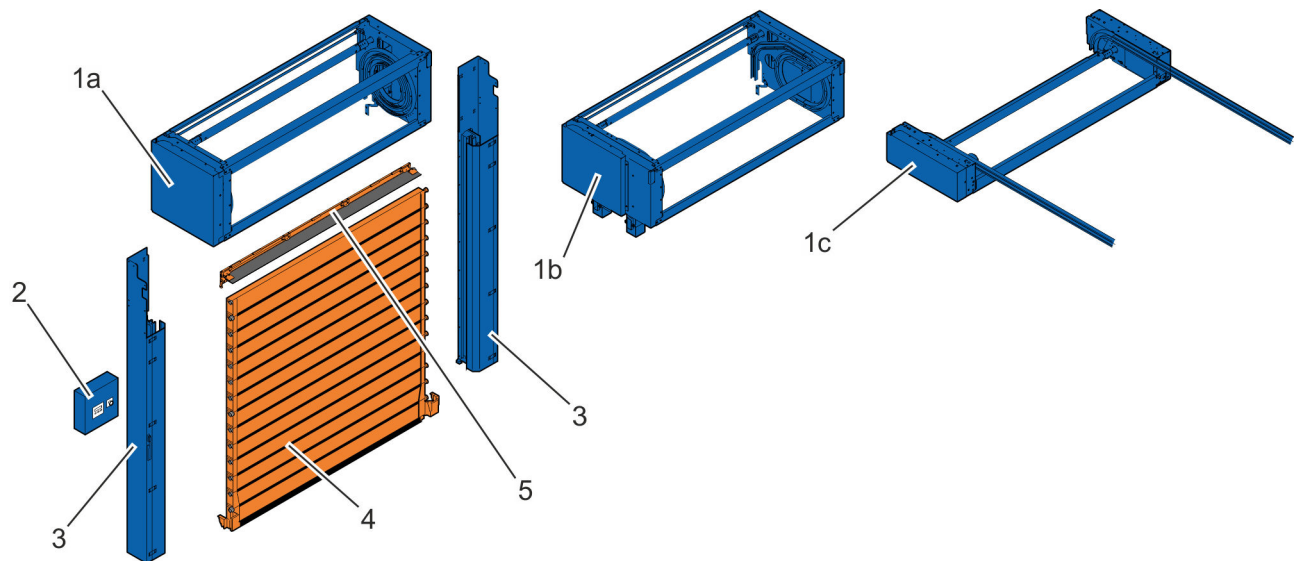

Fig. 11: Assemblies

1	Spiral case round (item 1a), oval (item 1b) or low (item 1c) with main support, spiral guide, motor, drive shaft, bearing, reinforcement profiles, cover (optional)	<ul style="list-style-type: none"> ↳ “Overview of drives”, starting on page 38 ↳ “Spiral case versions” starting on page 18
2	Control unit	↳ “Overview of the controls”, starting on page 40
3	Side frames with vertical door leaf guide, tooth belt for door leaf, weight counterbalance and door light grid	<ul style="list-style-type: none"> ↳ ‘Door leaf guide, side frame and optional pivoting side frame cover’ on page 25 ↳ ‘Transmission of force’ on page 21 ↳ ‘Counterbalance’ on page 22 ↳ “Door light grid” starting on page 45
4	Door leaf	↳ ‘Door leaf’ on page 27
	Laths	↳ “Overview of laths”, starting on page 28
	Safety edge	↳ “Safety edge and light barrier” starting on page 45
5	Horizontally folding seal	↳ “Seal” starting on page 37

Construction of the high-speed spiral door

Spiral console

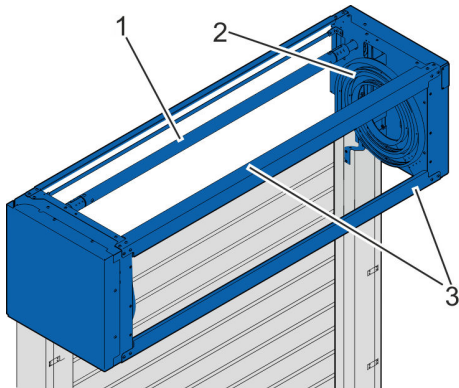

Fig. 12: Round spiral console

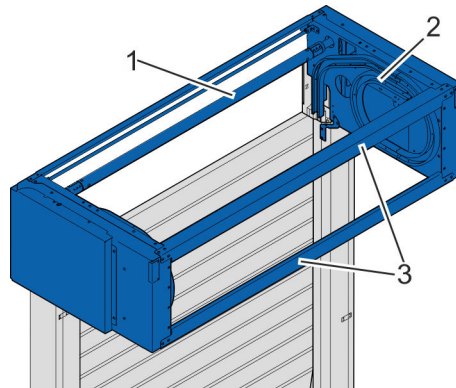

Fig. 13: Oval spiral console

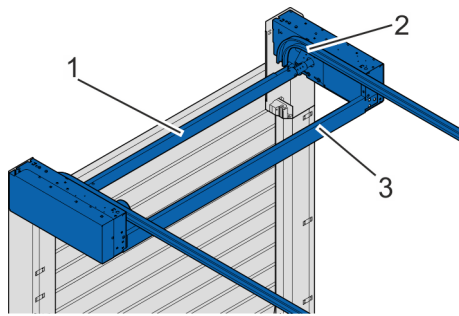

Fig. 14: Low spiral console

The spiral console is available in versions "round", "oval" and "low".

The spiral console comprises:

- Synchronous shaft with bearing (item 1)
- bevelled, main supports with spiral guide (item /2) on both sides
- Sheet metal reinforcement profiles (item 3)

Spiral case cover (optional)

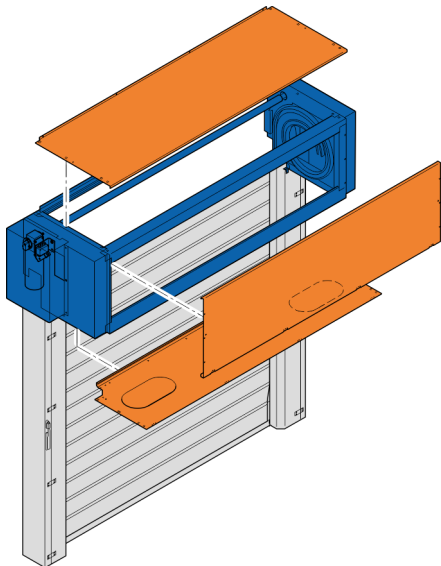

Fig. 15: Spiral case cover with sheet metal profiles

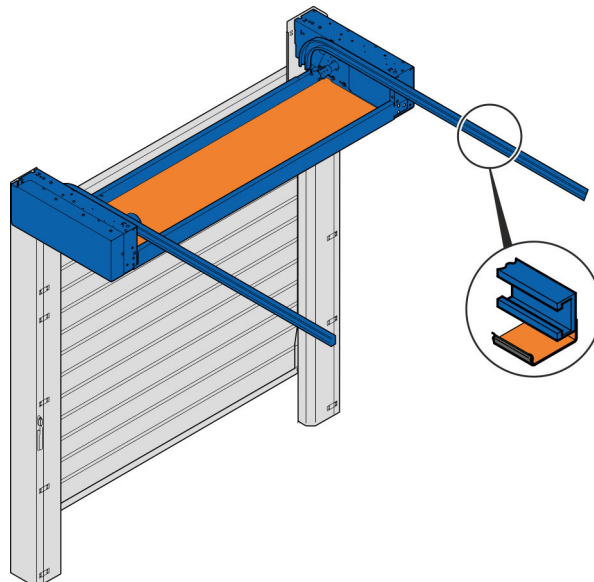

Fig. 16: Low lintel spiral case cover

Construction of the high-speed spiral door

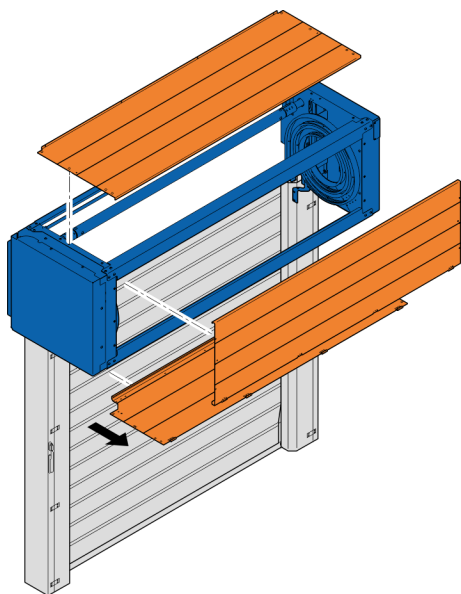

Fig. 17: Spiral case cover with lath profiles



Depending on the door system, the sheet metal profiles are equipped with inspection openings, which can be opened for maintenance purposes if necessary.

The cover for each of the round spiral and oval spiral has two inspection openings.

On door systems with a low lintel design, there are no inspection openings in the cover.

If the door system is covered with lath profiles, the lath profiles can easily be pulled out of the guide and removed by hand.

The spiral case cover comprises either sheet metal profiles (Fig. 15) or lath profiles (Fig. 17).

The spiral case can optionally be covered at the bottom, front and top. The covers may reduce the clear height.

Covers on the front and bottom are only possible in combination. The top cover is only possible if the front and bottom are also covered. On door systems with an oval spiral, the cover options available can be seen in the following overview [page 19](#). On door systems with a low lintel design, the bottom cover also covers the front cover up to the maximum possible coverable area of the spiral case. A further cover is not possible on low lintel door systems.



The spiral case cover to prevent access is mandatory for door systems with a height of less than 2500 mm or 2300 mm with low lintel.

Door system type	Sheet metal profile			Lath profile			Hinged side frame cover
	bottom + front	top	Restriction of clear height	bottom + front	top	Restriction of clear height	
260 R	available	available	40 mm	available	available	70 mm	available
260 O	Up to H = 3000 mm	-	40 mm	available	available	70 mm	available
261 R	available	available	45 mm	available	available	70 mm	available
261 O	Up to H = 3450 mm	-	45 mm	available	available	70 mm	available
262 R	available	available	55 mm	available	available	90 mm	•
263 R	available	available	40 mm	available	available	70 mm	available
263 O	Up to H = 3000 mm	-	40 mm	available	available	70 mm	available

Construction of the high-speed spiral door

Door system type	Sheet metal profile			Lath profile			Hinged side frame cover
	bottom + front	top	Restriction of clear height	bottom + front	top	Restriction of clear height	
263 N	available	-	-	-	-	-	available
264 R	available	available	45 mm	available	available	70 mm	available
264 O	Up to H = 3450 mm	-	45 mm	available	available	70 mm	available
264 N	available	-	-	-	-	-	available
265 R	available	available	40 mm	available	available	70 mm	available
265 O	Up to H = 3000 mm	-	40 mm	available	available	70 mm	available
265 N	available	-	-	-	-	-	available
268 R	available	available	60 mm	-	-	-	•
305 R	available	available	60 mm	-	-	-	•

• Standard

- not available

Transmission of force

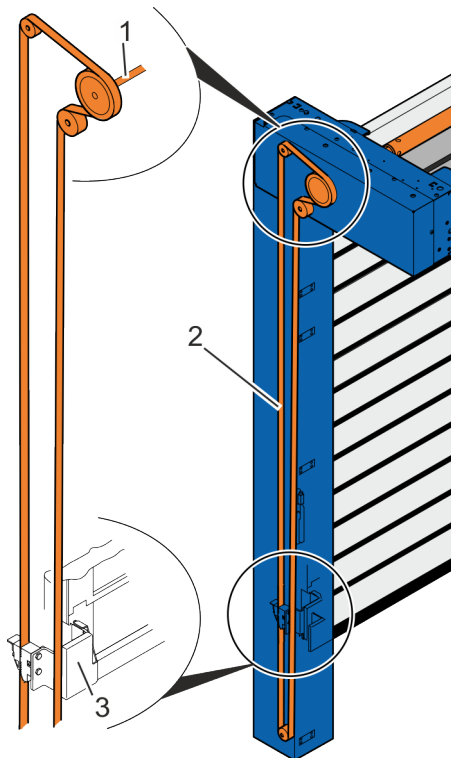

Fig. 18: Low lintel transmission of force

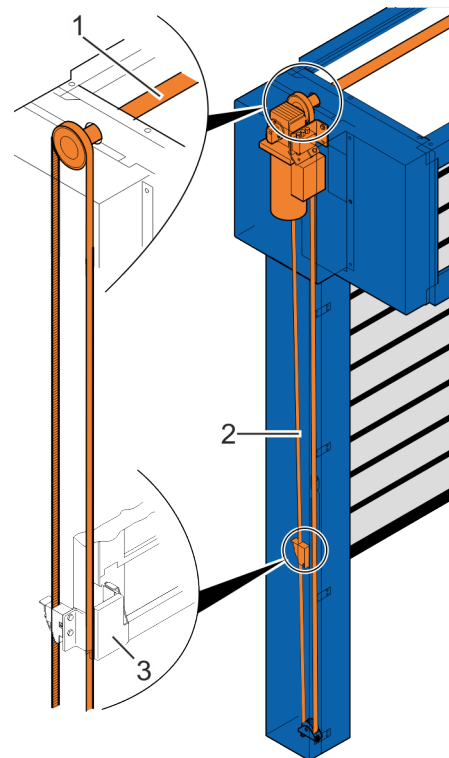

Fig. 19: Round and oval spiral transmission of force

The transmission of force from the drive to the door leaf is performed by the synchronous shaft (Fig. 18/1 and Fig. 19/1), the continuous toothed belt (Fig. 18/2 and Fig. 19/2) and the door leaf mounts (Fig. 18/3 and Fig. 19/3). Unlike a chain, the toothed belt runs very quietly.

The door leaf mounts are situated on the right and left-hand sides of the door leaf and are screwed to the hinge chains and the lowest lath of the door leaf (bottom lath). The hinge chains on both sides of the door system connect the bottom lath to the other laths. When the door leaf moves, the force is only applied to the bottom lath. All the other laths are fastened to the hinge chain and are moved at the same time without the effect of force.

Construction of the high-speed spiral door

Counterbalance

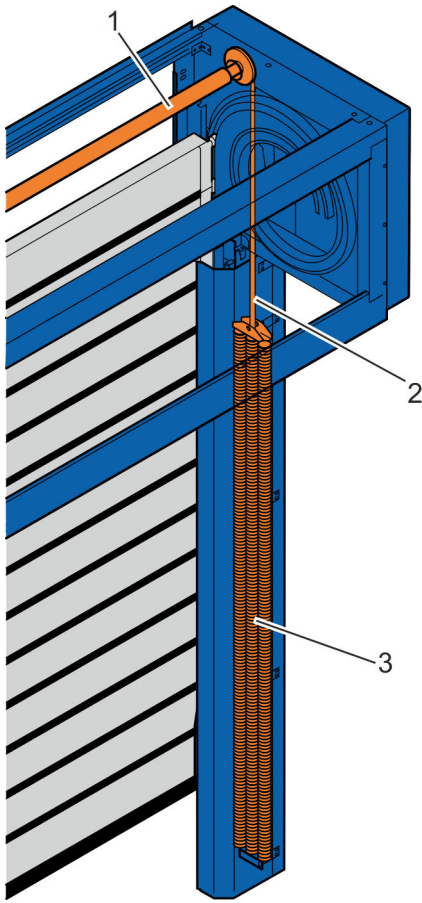

Fig. 20: Counterbalance

The door leaf counterbalance is a back pull mechanism: Tension springs (Fig. 20/3) are installed in the side frames. The tension springs are connected to the synchronous shaft (Fig. 20/1) by heavy-duty belts (Fig. 20/2). The tension springs are tensioned when the door system is closed and relaxed when the door system is open.

This way the door system can also be opened by hand (without electrical power) in case of emergencies. In normal mode the motor is assisted by the force of the tension springs.

The spring tension is calculated for each individual door.

Manual release lever



Fig. 21: Manual release lever on the side frame (left) and on a separate console (right)

The manual release lever is situated on the side frame or optionally on a separate console. When the lever is pulled gently, the motor brake is released and the door leaf is lifted by the spring counterbalance. The door system can be opened completely by pushing the door leaf upwards manually. The control unit is in EMERGENCY STOP status during this operation. The manual release lever is not designed for regular opening of the door system and does not have a catch position.

The manual release lever is also available in a lockable design (optional).

Door locking mechanism (optional)

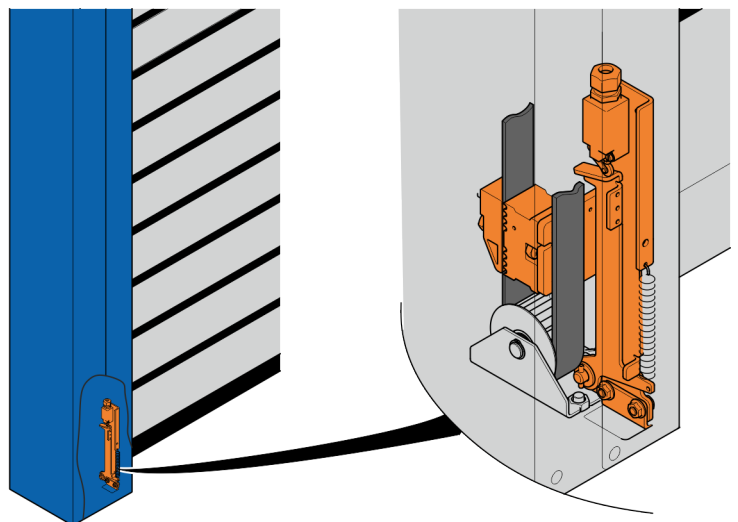
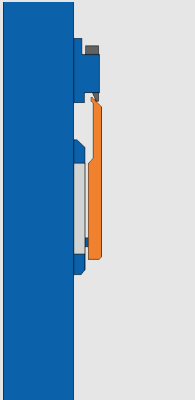
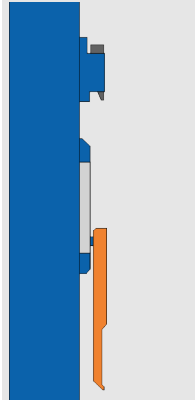
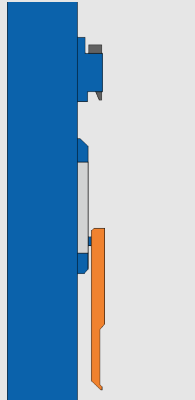
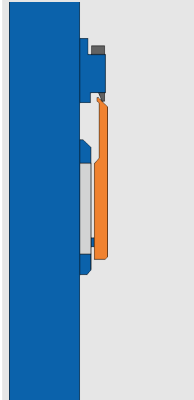
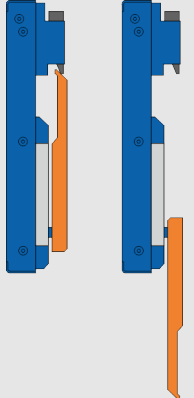

Fig. 22: Door locking mechanism

The mechanical locking mechanism is installed in the vertical side frame on the motor side. The locking mechanism handle keeps the door leaf closed so that it is safe from break-ins. The door locking mechanism is operated using a lever which is fitted to the side frame or on an optional separate console.

Construction of the high-speed spiral door

The following versions are possible:

Standard version: Lever fitted to side frame		Optionally: Lever fitted to the side frame with reversed lever position		Optionally: Lever fitted to a separate console
Door leaf not locked	Door leaf locked	Door leaf not locked	Door leaf locked	
				
Lever position: Lever up	Lever position: Lever down	Lever position: Lever down	Lever position: Lever up	The lever position depends on laying of Bowden cable
Optional locking version			Optional locking version	Lever position up, optional locking version

Door leaf guide, side frame and optional pivoting side frame cover

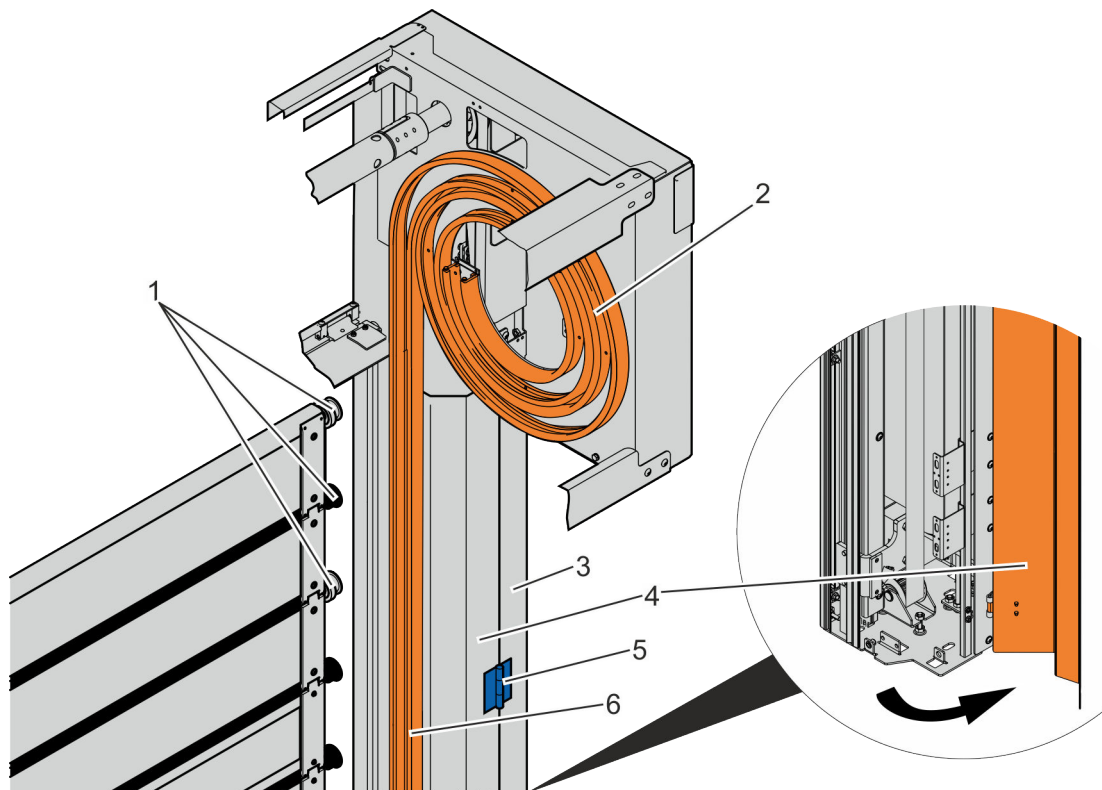

Fig. 23: Door leaf guide

The door leaf comprises laths which are connected by a hinge chain. Rollers (Fig. 23/1) are attached to the hinge chain. When the door system is opened and closed, the rollers are directed through the vertical (Fig. 23/6) and spiral-shaped (Fig. 23/2) door leaf guide. Very little noise is generated by the rolling of the rollers in the door leaf guide. The roller friction also ensures minimum wear on the rollers as no soiling is generated from abrasion. There is no wear on the door leaf itself. This gives the door system a long service life.

The vertical door leaf guides (Fig. 23/6) are made of sheet metal and aluminium profiles and are situated within the side frames (Fig. 23/3). Each side frame is made up of one main bevelled sheet metal profile and one bevelled sheet metal cover profile (Fig. 23/4). The sheet metal cover profiles are fastened with screws and can also be supplied in a pivoting design with hinges (Fig. 23/5).

For more information about this door-specific design option, see [table starting on page 19](#).

Resistance class 2 (RC2) as defined in DIN V ENV 1627:1999-04 and (RC2) as defined in DIN/TS 18194:2020

Due to the design listed below, the door systems 260 R, 260 O, 261 R, 261 O, 263 R, 263 O, 264 R, 264 O, 265 R and 265 O achieve resistance class 2 after each complete closing in the "Door closed" position and subsequent operation of the door locking mechanism ([‘Door locking mechanism \(optional\)’ on page 23](#)).

Construction of the high-speed spiral door

Resistance class 2 is only achieved if the door leaf is in the “Door closed” position and the locking mechanism is operated at the same time – i.e. the door leaf is locked.

Resistance class 2 means that an opportunist with simple tools such as screwdrivers, pliers and wedges cannot break (open or penetrate) the door system within three minutes.

This applies to the following equipment:

- EFA-THERM® lath with 0.4 mm steel plate (↪ ‘EFA-THERM® lath’ on page 28)
- Emergency operation device on the side frame, lockable
- Locking mechanism on the side frame
- No single-walled EFA-CLEAR® transparent laths
- No EFA-VENT® ventilation laths
- One double-walled EFA-CLEAR® transparent lath with SAN filling – One EFA-THERM® lath – One double-walled EFA-CLEAR® transparent lath with SAN filling
 - Two double-walled EFA-CLEAR® transparent laths with SAN filling must not be arranged directly above one another. There must be at least one EFA-THERM® lath in between.
- Max. four double-walled EFA-CLEAR® transparent laths with PC-H filling – One EFA-THERM® lath – max. four double-walled EFA-CLEAR® transparent laths with PC-H filling – etc.
 - No more than four double-walled EFA-CLEAR® transparent laths with PC-H filling must be arranged directly above one another. There must be at least one EFA-THERM® lath in between.
- The use of a side frame extension must be examined on a case-by-case basis.
- The use of screw-through assembly must be examined on a case-by-case basis.

The door system type is listed in what is known as the “KPK list” (KPK: Kommission Polizeiliche Kriminalprävention; Commission for Crime Prevention), which can be accessed online via the Bavarian State Criminal Police Office. This KPK list records tested and certified burglar-resistant products and is updated twice a year as scheduled.



Fig. 24: Seal manufacturer directories

Door leaf

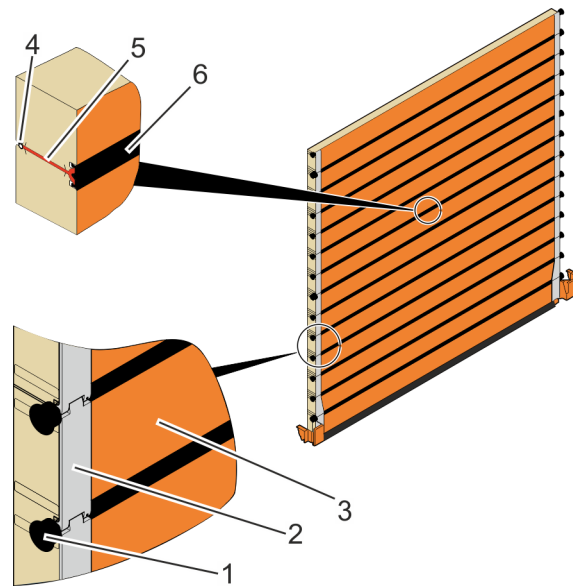

Fig. 25: Door leaf

The door leaf is assembled from laths (Fig. 25/3) which are held at the correct spacing by hinge chains (Fig. 25/2) attached at the sides. This spacing prevents contact between the laths. They are thus free from wear. The forces for opening and closing the door system are transmitted via hinges.

Ball-bearing mounted rollers (Fig. 25/1) keep the door leaf firmly in the guides in the horizontal direction. The laths are connected to each other by rubber hinges (Fig. 25/6) and O-profile seals (Fig. 25/4). An air cushion (Fig. 25/5) is created between. It provides similarly effective insulation as that of the laths.

This homogeneous door leaf construction ensures the very good running performance, the high running speed and the excellent U-value.

The thickness of the door leaf varies depending on the door system type.

Door system type	Thickness of the door leaf
260 R; 260 O	40 mm
263 R; 263 O; 263 N	
265 R; 265 O; 265 N	
261 R; 261 O	60 mm
264 R; 264 O; 264 N	
262 R	80 mm
268 R	
305 R	100 mm

Construction of the high-speed spiral door

EFA-THERM® lath

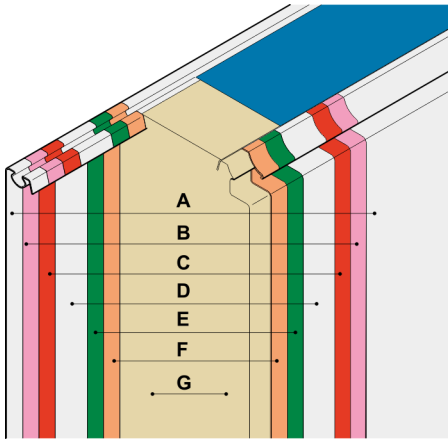

Fig. 26: Structure of the EFA-THERM® lath

The EFA-THERM® laths are structured with the following layers:

- A Top coat
- B Primer
- C Zinc coat 150 g/m²
- D Sheet (made of steel or aluminium coil)
- E Zinc coat 150 g/m²
- F Adhesive
- G PU hard foam, 42 kg/m³, CFC and HCFC free

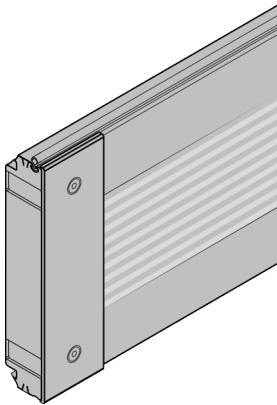

Fig. 27: EFA-THERM® lath

Dimensions	40/60/80 × 222 mm
Material	Steel plate 0.4 mm For door system width ≤ 3,500 mm and 40 mm Lath: Aluminium plate 0.6 mm
Finish	2 coats of paint
Colour	White aluminium, similar to RAL 9006 or RAL 9007
Optional	Wet lath coating Colours in compliance with SAP

Only for door system 305 R

Dimensions	100 × 222 mm
Material	Steel plate 0.4/0.6 mm ^x
Finish	2 coats of paint
Colour	White aluminium, similar to RAL 9006

x depending on the application

Construction of the high-speed spiral door

Designs of the EFA-THERM® lath

		Door system type		260 R+O (L1) 263 R+O (L1) 265 R+O (L1)	260 R+O (L2) 263 R+O (L2) 265 R+O (L2)	261 R+O 264 R+O	262 R
		Side frame dimensions in mm		175/230 × 230	240 × 240	280/305 × 340	350 × 380
		Surface/colour					
Sheet thickness	Material	Coil colour	RAL paint				
0.4 mm	Steel	9006	-	*	available	available	available
0.6 mm	Aluminium	9006	-	available	*	-	-
0.4 mm	Steel	9007	-	*	available	available	available
0.4 mm	Steel	-	as per SAP	*	available	available	available
0.6 mm	Aluminium	-	as per SAP	available	*	-	-
0.6 mm	Steel	9006	-	-	-	-	-

		Door system type		263 N 265 N	264 N	268 R	305 R (Fig. 28, Fig. 29)
		Side frame dimensions in mm		250 × 340	290/360 × 360	350 × 380	502 × 550
		Surface/colour					
Sheet thickness	Material	Coil colour	RAL paint				
0.4 mm	Steel	9006	-	available	available	available	x
0.6 mm	Aluminium	9006	-	available	-	-	-
0.4 mm	Steel	9007	-	available	available	available	-
0.4 mm	Steel	-	as per SAP	available	available	available	-
0.6 mm	Aluminium	-	as per SAP	available	-	-	-
0.6 mm	Steel	9006	-	-	-	-	x

* available on special request

- not available

x depending on the application

Construction of the high-speed spiral door

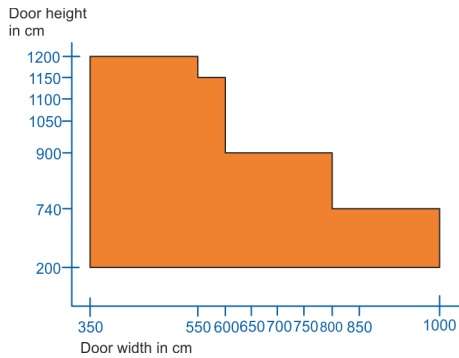

Fig. 28: Door size, sheet thickness 0.6 mm

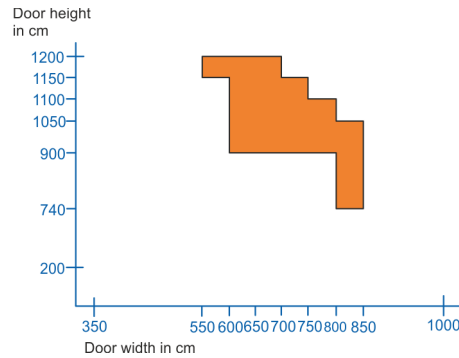

Fig. 29: Door size, sheet thickness 0.4 mm

EFA-CLEAR® transparent lath, double-walled (optional)

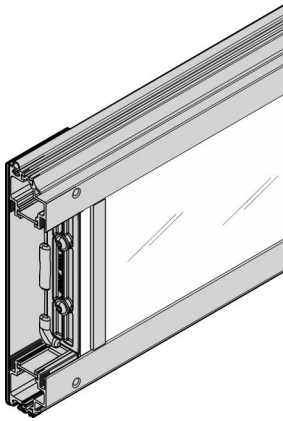

Fig. 30: Transparent lath (double-walled)

The EFA-CLEAR® double-walled, thermally insulated transparent laths are each comprised of two plastic panes which are pressed at intervals into aluminium profiles between the panes.

Dimensions	40/60 × 222 mm Height of viewing area: approx. 135 mm
Finish	E6/EV1 (natural anodised)
Glazing	SAN panes Hard polycarbonate panes (scratch resistant) SAN panes with frosted glass finish and 75% translucency (on request)
Optional	Aluminium profile coating Colours in compliance with SAP

The number of transparent laths is limited.

Construction of the high-speed spiral door

Only for door system 262 R, 268 R, 305 R

The EFA-CLEAR® double-walled, thermally insulated transparent laths are each comprised of two plastic panes which are pressed at intervals into GRP profiles between the panes.



For door systems 262 R, 268 R: Above door system width (B) \geq 5,170 mm, the laths come with a middle bar.



For door system 305 R: Above door system width (B) \geq 5,230 mm, the laths come with a middle bar.

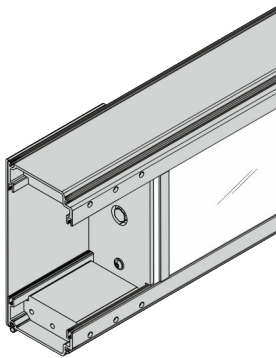

Fig. 31: Transparent lath (double-walled) 262 R, 268 R, 305 R

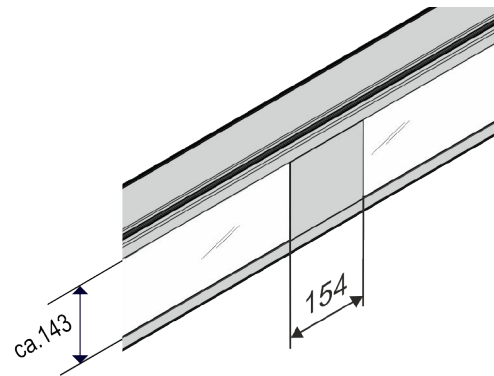

Fig. 32: Width, middle bar

Dimensions	80/100 × 222 mm Viewing area height: approx. 143 mm
Finish	1 coats of paint GRP profiles including lath protective sheets, screws and middle bar)
Colour	White aluminium, similar to RAL 9006
Glazing	PMMA
Optional	GRP profile coating Colours in compliance with SAP

The number of transparent laths is limited.

Construction of the high-speed spiral door

EFA-CLEAR® transparent lath, single-walled (optional)

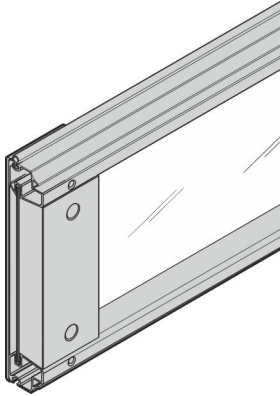

Fig. 33: Transparent lath (single-walled)

The EFA-CLEAR® transparent lath is made up of transparent plastic panes pressed into aluminium profiles.

Dimensions	40/60 × 222 mm Height of viewing area: approx. 155 mm
Finish	E6/EV1 (natural anodised)
Glazing	SAN panes Hard polycarbonate panes (scratch resistant) SAN panes with frosted glass finish and 75% translucency (on request)
Optional	Aluminium profile coating Colours in compliance with SAP

The number of transparent laths is limited.

EFA-VENT® ventilation lath (optional)

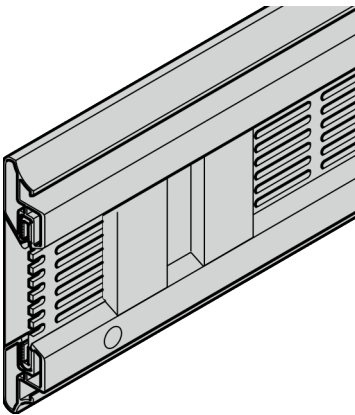

Fig. 34: Ventilation lath

The EFA-VENT® ventilation lath comprises aluminium metal sheets with elongated holes (50 × 6 mm) which are pressed into aluminium profiles.

Dimensions	40/60 × 222 mm
Finish	Anodised E6/EV1
Vent cross-section in m ²	$LA = ((B - 0.105) \times 0.066) \times \text{number of laths}$ B = door system width in metres
Optional	Varnish for aluminium profiles and ventilation sheets Colours in compliance with SAP

The number of ventilation laths is limited.

Door leaf versions

EFA-VENT® ventilation laths and single-walled EFA-CLEAR® transparent laths cannot be used for the door system types 262 R, 268 R and 305 R.

LA1

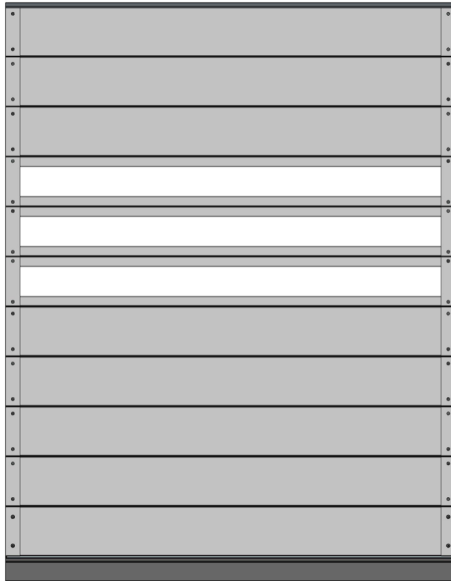

View from the outside

- EFA-THERM® lath, steel/aluminium sheet, surface similar to RAL 9006
- EFA-THERM® lath protective sheet (aluminium), surface E6/EV1 (natural anodised) and screws galvanised/stainless steel
- EFA-CLEAR® lath, single or double glazing or ventilation lath (aluminium), surface E6/EV1 (natural anodised) and screws galvanised/stainless steel
- EFA-CLEAR® lath type 262 R, 268 R and 305 R with lath protective sheet and screws in wet varnish similar to RAL 9006

Fig. 35: Door leaf design LA1

LA2 (not for 305 R)

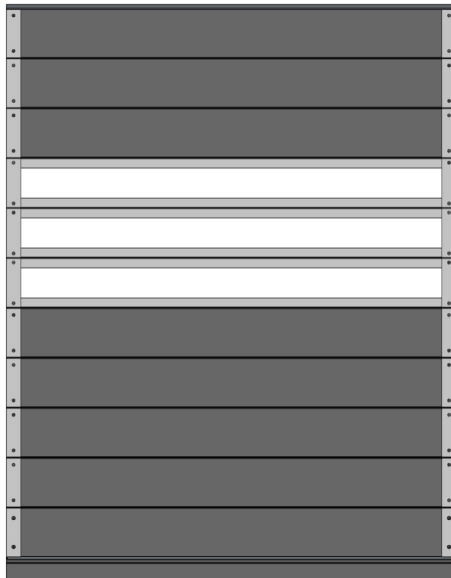

View from the outside

- EFA-THERM® lath, steel sheet, surface similar to RAL 9007
- EFA-THERM® lath protective sheet (aluminium), surface E6/EV1 (natural anodised) and screws galvanised/stainless steel
- EFA-CLEAR® lath, single or double glazing or ventilation lath (aluminium), surface E6/EV1 (natural anodised) and screws galvanised/stainless steel
- ELA-CLEAR® lath type 262 R and 268 R with lath protective plate and screws in wet varnish similar to RAL 9006

Fig. 36: Door leaf design LA2

Construction of the high-speed spiral door

LA3 (not for 305 R)

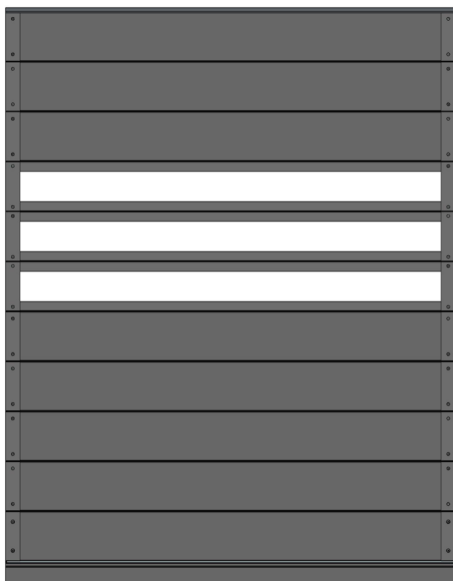

View from the outside

- EFA-THERM® lath, steel sheet, surface similar to RAL 9007
- EFA-THERM® lath protective sheet (aluminium) and screws with wet varnish similar to RAL 9007
- EFA-CLEAR® lath, single or double glazing or ventilation lath (aluminium) with wet varnish similar to RAL 9007

Fig. 37: Door leaf design LA3

LA4 (not for 305 R)



View from the outside

- EFA-THERM® lath, steel sheet, surface similar to RAL 9007
- EFA-THERM® lath protective sheet (aluminium) and screws with wet varnish similar to RAL 9007
- EFA-CLEAR® lath, single or double glazing or ventilation lath (aluminium), surface E6/EV1 (natural anodised) and screws galvanised/stainless steel
- EFA-CLEAR® lath type 262 R with 268 R lath protective plate and screws in wet varnish similar to RAL 9006

Fig. 38: Door leaf design LA4

LA1 (interior)

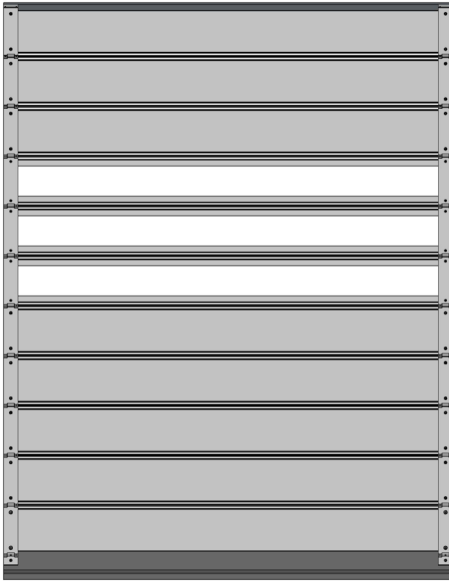

View from the inside

- EFA-THERM® lath, steel/aluminium sheet, surface similar to RAL 9006
- Hinge chain (aluminium), surface E6/EV1 (natural anodised) and screws galvanised/stainless steel
- EFA-CLEAR® lath, single or double glazing or ventilation lath (aluminium), surface E6/EV1 (natural anodised) and screws galvanised/stainless steel

Fig. 39: Door leaf design LA1, interior

LA2 and LA4 (interior) (not for 305 R)

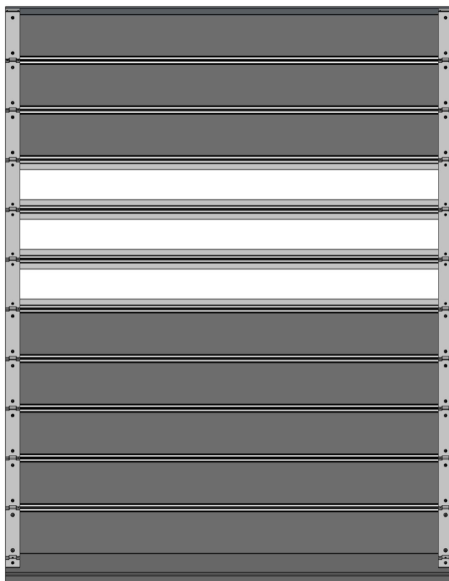

View from the inside

- EFA-THERM® lath, steel/aluminium sheet, surface similar to RAL 9007
- Hinge chain (aluminium), surface E6/EV1 (natural anodised) and screws galvanised/stainless steel
- EFA-CLEAR® lath, single or double glazing or ventilation lath (aluminium), surface E6/EV1 (natural anodised) and screws galvanised/stainless steel

Fig. 40: Door leaf design LA2 and LA4, interior

Construction of the high-speed spiral door

LA3 (interior) (not for 305 R)

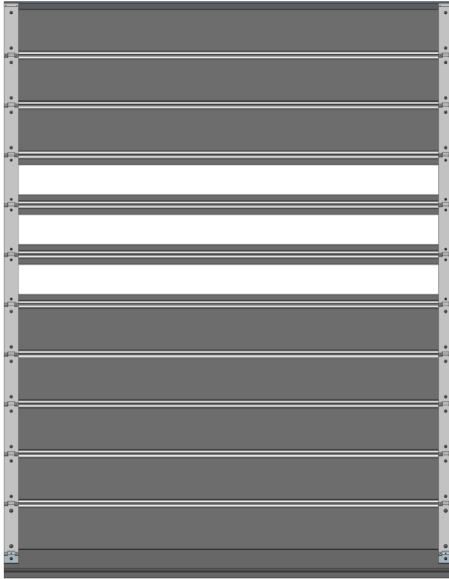

View from the inside

- EFA-THERM® lath, steel/aluminium sheet, surface similar to RAL 9007
- Hinge chain (aluminium), surface E6/EV1 (natural anodised) and screws galvanised/stainless steel
- EFA-CLEAR® lath, single or double glazing or ventilation lath (aluminium) with wet varnish similar to RAL 9007

Fig. 41: Door leaf design LA3, interior

Seal

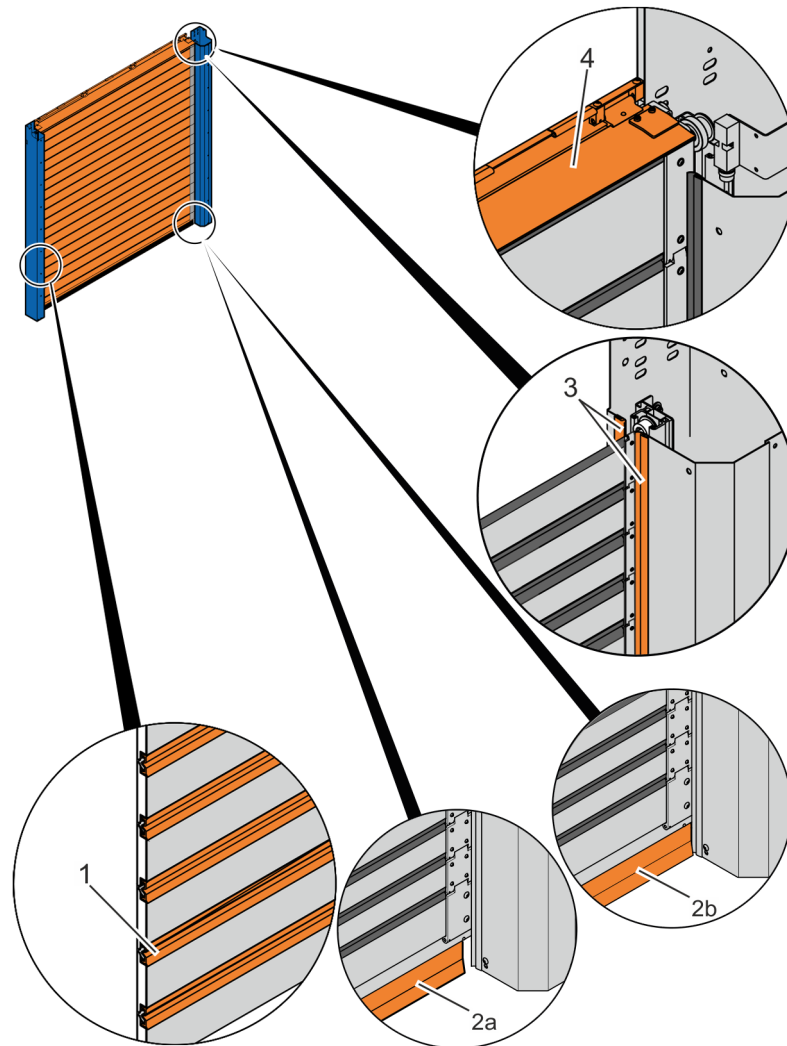

Fig. 42: Seal

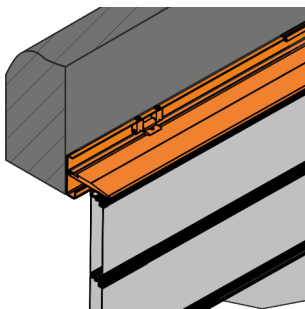

Fig. 43: Sealing profile closed

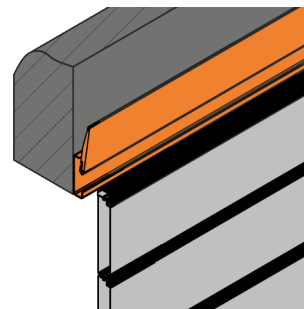

Fig. 44: Sealing profile open

Construction of the high-speed spiral door

The low-wear plastic door leaf seals (Fig. 42/3) provide the vertical sealing effect. For door system types 263 N, 264 N and 265 N, the length of the horizontal rubber profile (Fig. 42/2a) is B -15 mm for structural reasons. On all other door system types with this product description, the rubber profile protrudes as far as the side frame on the left and right (Fig. 42/2b). The laths are sealed off by rubber hinges, one below the other (Fig. 42/1).

A horizontal, folding sealing profile (Fig. 42/4) provides the seal between the lintel, door leaf and side frames. The sealing profile folds down automatically when the door system is closed and is pressed mechanically onto the door leaf (Fig. 43).

On door systems with a round or oval spiral, the sealing profile is made of aluminium and seals off on the rubber profile of the top lath. The height of the sealing profile is determined by the door system height, i.e. the door system height and lath spacing.

On door systems with a low lintel, the sealing profile is made of fabric reinforced PVC and seals at the top lath.

Overview of the drives

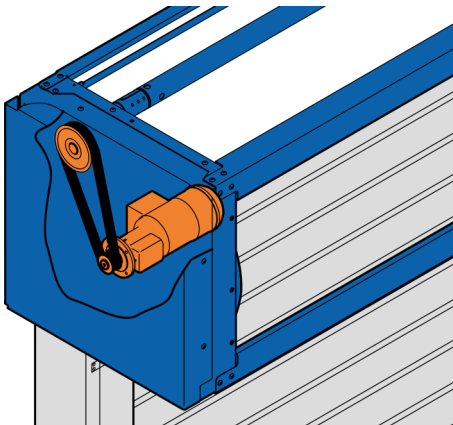

Fig. 45: Drive, door types "260 R", "260 O", "261 R", "261 O", "263 R", "263 O", "263 N", "264 R", "264 O", "264 N", "265 R", "265 O", "265 N"

260 R; 260 O
261 R; 261 O
263 R; 263 O; 263 N
264 R; 264 O; 264 N
265 R; 265 O; 265 N

Drive type	Integrated into the spiral to save space; transmission of force via toothed belt (Spur gear, asynchronous AC motor)
Power classes	0.25 kW – 1.5 kW
Protection type	IP 54
Position detection	Door types "260 R", "260 O", "261 R", "261 O": Absolute encoder. Thus no reference run is required. Door types "263 R", "263 O", "263 N", "264 R", "264 O", "264 N", "265 R", "265 O", "265 N": Incremental encoder

Construction of the high-speed spiral door

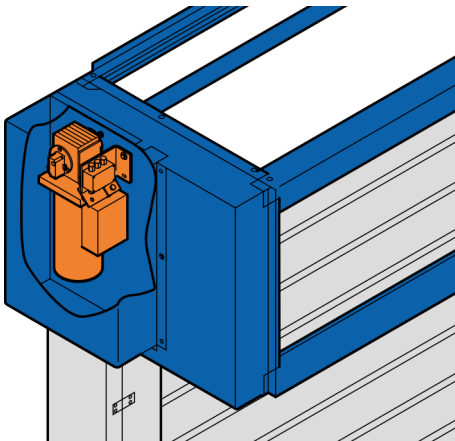

Fig. 46: Drive, door type "262 R"

262 R

Drive type	Direct mount drive (Spur gear asynchronous AC motor)
Power classes	2.2 kW
Protection type	IP 54
Position detection	Absolute encoder. Thus no reference run is required.

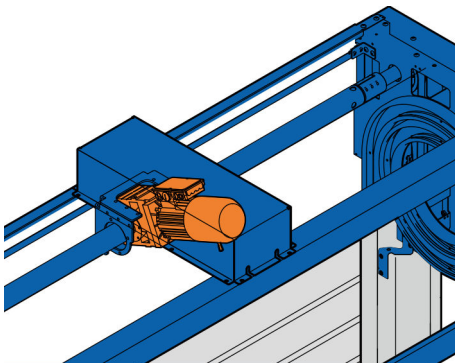

Fig. 47: Drive, door type "268 R" and "305 R"

268 R

Drive type	Direct mount drive (Spur gear asynchronous AC motor)
Power classes	2.2 kW
Protection type	IP 54
Position detection	Absolute encoder. Thus no reference run is required.

305 R

Drive type	Direct mount drive (Spur gear asynchronous AC motor)
Power classes	3.0 kW
Protection type	IP 54
Position detection	Absolute encoder. Thus no reference run is required.

Construction of the high-speed spiral door

Controls

Door system type	EFA-TRONIC®	EFA-TRONIC® Professional	EFA-TRONIC® light	Standard installation position
260 R; 260 O	●	○	-	On the side, next to the side frame
261 R; 261 O	●	○	-	
262 R	-	●	-	
263 R; 263 O; 263 N	●	○	-	
264 R; 264 O; 264 N	●	○	-	
265 R; 265 O; 265 N	○	○	●	On the side, next to the side frame, max. 3 m away from the door system
268 R	-	●	-	
305 R	-	●	-	

- Standard
- optional
- not available

EFA-TRONIC control unit®

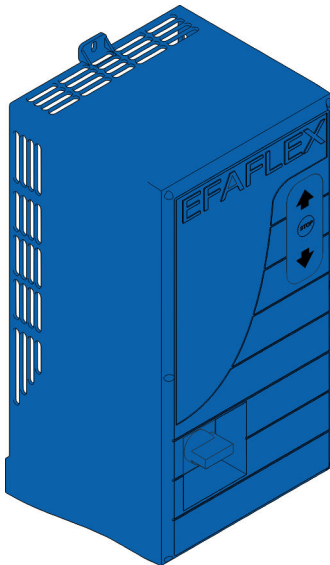

Fig. 48: EFA-TRONIC control unit®

Control unit	EFA-TRONIC® with frequency converter
Size (W × H × D)	210 × 400 (565)* × 200 mm (* incl. cable cover)
Housing	Polycarbonate housing
Protection type	IP65
Viewing window for display	Display of status messages and fault messages
Operating controls	Operating panel for operation and configuration of the door system Master switch
Supply voltage	L/N/PE 230 V ± 10 % or 3~L/N/PE 400 V ± 10 %
Frequency	50 – 60 Hz
Supply cable	Fuse protection 16 A to be provided by the user (K characteristic)
With residual current device (RCD) as necessary	300 mA in compliance with DIN VDE 0100-530 (sensitive to universal current)

Construction of the high-speed spiral door

EFA-TRONIC® Professional

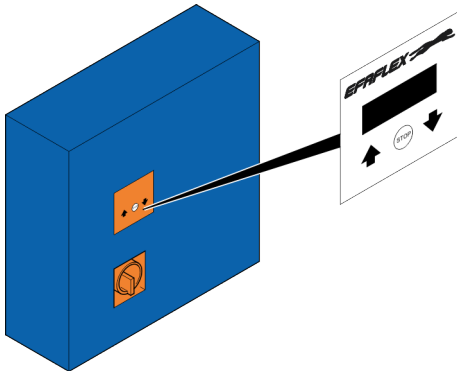

Fig. 49: EFA-TRONIC® Professional

Control unit	EFA-TRONIC® Professional with frequency converter
Size (W × H × D)	380 × 380 × 210 mm
Housing	Steel, colour RAL 7035 Optionally: ■ Painted RAL, colours in compliance with SAP ■ V2A
Protection type	IP54
Viewing window for display	Display of status messages and fault messages
Operating controls	Operating panel for operation and configuration of the door system Master switch
Supply voltage	L/N/PE 230 V ± 10 % or 3~L/N/PE 400 V ± 10 %
Frequency	50 – 60 Hz
Supply cable	Fuse protection of 16 A to be provided on-site (K characteristic)
With residual current device (RCD) as necessary	300 mA in compliance with DIN VDE 0100-530 (sensitive to universal current)

Construction of the high-speed spiral door

EFA-HDI operating unit

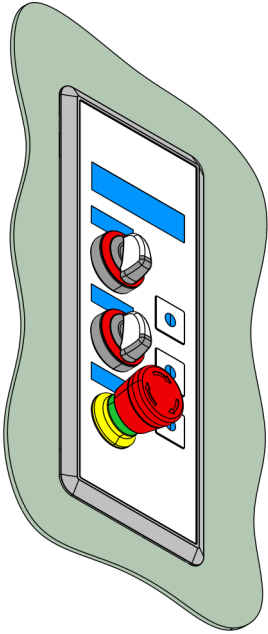

Fig. 50: EFA-HDI operating unit

An option to mount an additional operating unit on the wall is available as an enhancement of the EFA-TRONIC®. It is equipped with a display screen and offers full access to all parameters and all basic functions.

EFA-TRONIC® light control unit

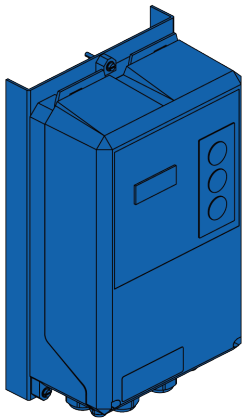

Fig. 51: EFA-TRONIC® light control unit

Control unit	EFA-TRONIC® light with frequency converter
Size (W × H × D)	182 × 328 × 121 mm
Housing	Polycarbonate housing
Protection type	IP54
Viewing window for display	Display of status messages and fault messages
Operating control	Operating panel for operation and configuration of the door system
Supply voltage	L/N/PE 230 V ± 10 %
Frequency	50–60 Hz
Supply cable	Fuse protection of 16 A to be provided by the user (K characteristic)
With residual current device (RCD) as necessary	300 mA in compliance with DIN VDE 0100-530 (sensitive to universal current)
Power supply	Standard: CEE plug 16A 1P blue (“L+N+PE+6h” in compliance with IEC 60309)

Integrated control unit

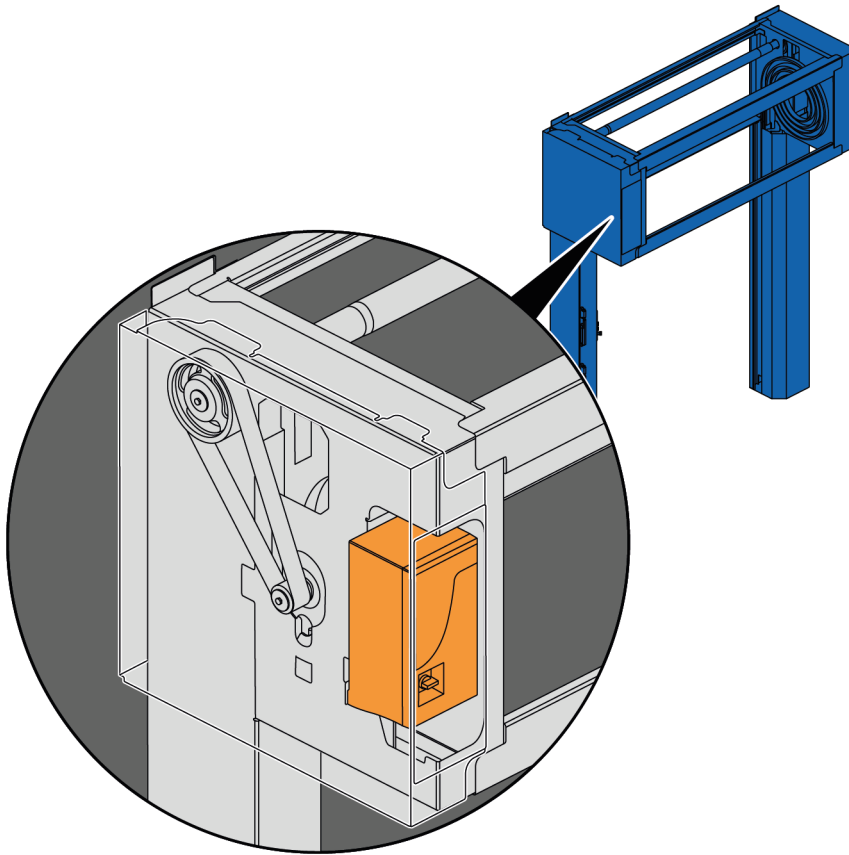

Fig. 52: Integrated control unit

The EFA-TRONIC[®] control unit can be optionally integrated in the console on the motor side for door types 261 R and 264 R (Fig. 52). For this option, the side frame covers always have a hinged design and the HDI is factory-installed in the side frame cover on the motor side (Fig. 53). A blue CEE three-pole socket (IEC 60309-2) must be prepared on site next to the motor side frame, since the power supply for the control unit is pluggable. The socket should be max. 500 mm away from the side frame at a height of approx. 1,000 mm. Only one HDI can be used per door system.

Construction of the high-speed spiral door

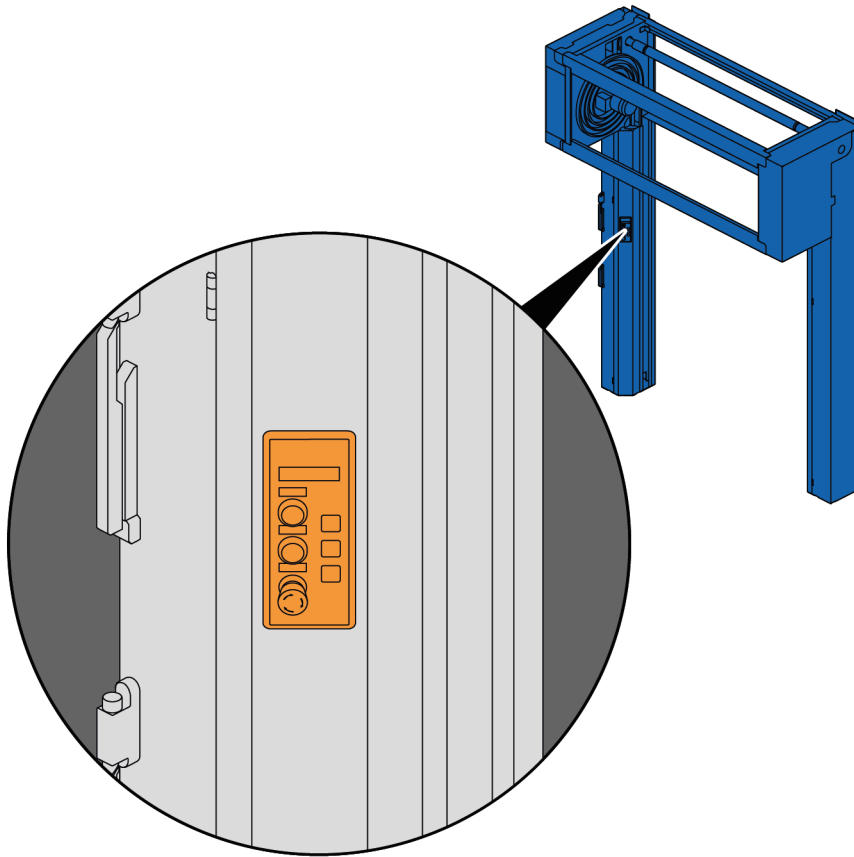

Fig. 53: HDI

4 Door safety

Available door safety

Door system type	Safety edge and light barrier	Door light grid
260 R; 260 O	○	●
261 R; 261 O	○	●
262 R	-	●
263 R; 263 O; 263 N	●	○
264 R; 264 O; 264 N	●	○
265 R; 265 O; 265 N	●	-
268 R	-	●
305 R	-	●

- Standard
- Optional
- Not available



Simultaneous installation of a door light grid and light barrier(s) is not possible.

The main closing edge is secured by a combination of a safety edge and light barrier(s) (C device plus D device). This achieves the minimum protection level in line with DIN EN 12453.



In addition, the owner and the manufacturer have to consult with one another on providing protection for the approach area. This will be based on the owner's risk assessment.

Door safety

Safety edge and light barrier

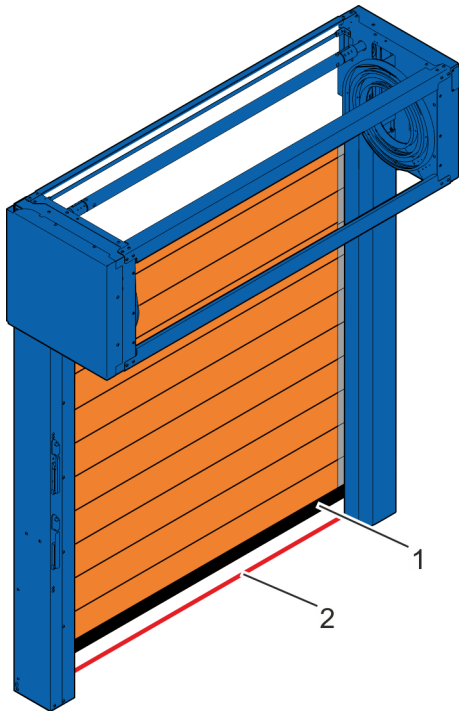

1	Safeguard for the closing edge	Safety edge
2	Light barrier (optional)	Unidirectional light barriers (IP67) max. 2

If the safety edge comes into contact with a person during the closing procedure, the door leaf stops, the door system opens completely and closes automatically again once the "keep-open" time has elapsed.

The light barriers, which are installed in the side frames at the sides, are offset from the door closing level. The height of the light barriers is variable.

Fig. 54: Safety edge and light barrier

Door light grid

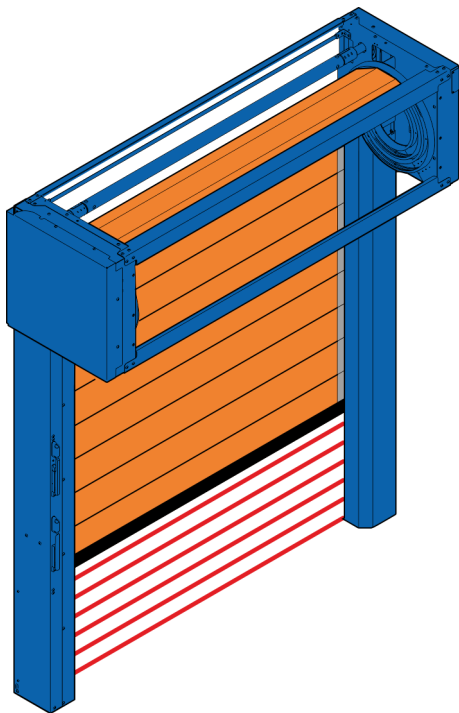

Fig. 55: Door light grid

The door light grid, which is installed in the side of the side frame, monitors the closing level, up to a height of 2.5 metres. The door light grid prevents the door system from closing when a person is detected in the danger area.

On door systems, an optional safety edge can be installed in addition to the door light grid. Simultaneous installation of a door light grid and light barrier is not possible.

5 Equipment

Possible equipment¹

- Galvanised basic door construction, 275 g/m²
- Round spiral, oval spiral or low lintel door leaf guide
- Pivoting side frame cover (262 R, 268 R and 305 R)
- EFA-THERM[®] lath, 40 × 222 mm, 60 × 222 mm, 80 × 222 mm or 100 × 222 mm
- EFA-TRONIC[®] control unit (264 R, 264 O, 264 N), EFA-TRONIC[®] Professional (268 R) or FUZZ-G (265 R, 265 O, 265 N)
- Emergency operation device on side frame, not lockable
- Door light grid or safety edge with light barrier
- Basic door construction, galvanised (275 g/m²), with powder-coated finish in the colours as per SAP
 - Polyester-based decorative powder coating
 - Coat thickness approx. 50 µm +/- 10 µm
 - Sheen level in compliance with DIN EN ISO 2813 (incidence angle 60°) 75 % ± 10 %
 - Smooth surface (no structure)
- Basic door construction, stainless steel V2A 1.4301, corrosion resistant, polished grain 220 (not for door systems of type 305)
- Double-walled EFA-CLEAR[®] transparent lath, 40 × 222 mm, 60 × 222 mm, styrene-acrylonitrile (SAN) or polycarbonate glazing
- Single-walled EFA-CLEAR[®] transparent lath, 40 × 222 mm, 60 × 222 mm, styrene-acrylonitrile (SAN) or polycarbonate glazing
- Double-walled EFA-CLEAR[®] transparent lath 262 R, 268 R and 305 R 80/100 × 222 mm, polymethyl methacrylate (PMMA) or polycarbonate glazing
- EFA-VENT[®] ventilation lath, 40 × 222 mm, 60 × 222 mm
- Laths
 - Polyurethane-based decorative coating
 - Coat thickness approx. 50 µm +/- 10 µm
 - Sheen level in compliance with DIN EN ISO 2813 (incidence angle 60°), 30 % ± 10 %
 - Smooth surface (no structure)
- EFA-TRONIC[®] or EFA-TRONIC[®] Professional control unit
- Door light grid
- Up to 2 light barriers
- Command devices: push-buttons, pull switches, key switches, etc.
- Command devices/safety: Radar detector, EFA-SCAN[®], IR (infrared presence sensor)
- Spiral case covers
- Locking mechanism
- Locking mechanism which can be shut off
- Hinged side frame cover
- Frame extension on both sides

Equipment

- “Door closed” limit switch, Schmersal roller lever switch type, Euchner CES safety limit switch, Pepperl + Fuchs NJ 15
- “Intermediate stop” limit switch, type Pepperl + Fuchs NJ 15
- “Type open” limit switch, Schmersal roller lever switch type
- EFA-HDI operating unit

¹ Depending on configuration

Special constructions

Special constructions/special orders are design types which are not covered, either mechanically or electrically, by standard versions in the sales price lists or by a design from the technology variants table. They have to be requested specifically. Surcharges and extended delivery times are calculated for special designs in accordance with the actual expenditure.

6 Packaging units

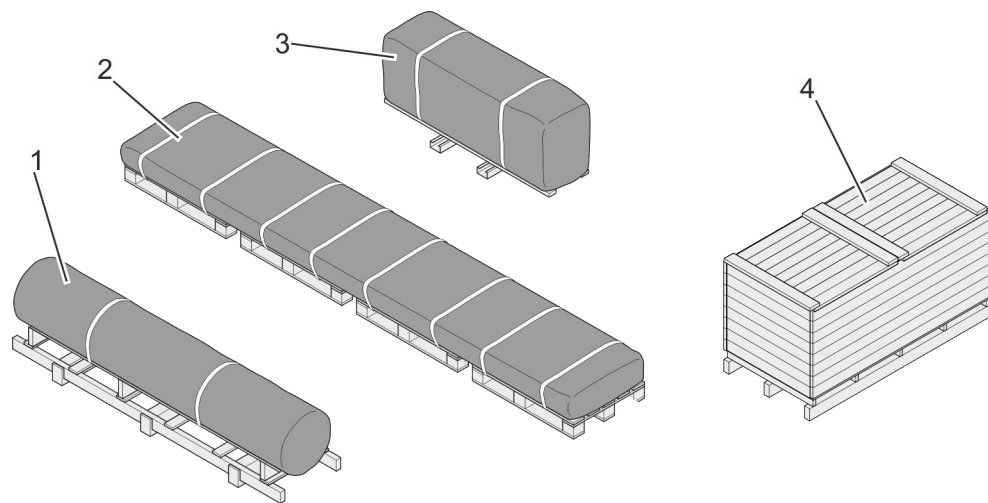

Fig. 56: Scope of delivery (left, standard transport unit), wooden crate (right, optionally for sea and fit-for-purpose* transport)



**Fit-for-purpose packaging is packaging which ensures that the packaged goods reach the recipient without damage, taking into account the shipping loads, shipping route, shipping duration and transportation load profile.*

Transport unit (example)

Transport unit 1: Door leaf package ("low lintel" version only)

Transport unit 2: Side frame sections with covers, control, accessories

Transport unit 3: Spiral case with door leaf, drive

Transport unit 4: Wooden crate (optional)

Number of transport units

The number of standard transport units depends on the selected number of door systems.

The door systems can also be delivered in a wooden crate. The number of wooden crates depends on the configuration of the door system types and the number of door systems.

The wood for the wooden crates optionally complies with the IPPC standard. For sea freight, the wooden crates are lined with film to protect them from moisture.

Packaging units

Packages which are fastened to pallets can be transported by fork lift under the following conditions:

- The fork lift must have the appropriate capacity for the weight of the packages.
- The package must be securely fastened to the pallet.
- The fork lift driver must be authorised to drive industrial trucks with a driver's seat or driver's station in accordance with the local regulations.



EFAFLEX Tor- und Sicherheitssysteme

GmbH & Co. KG

Fliederstraße 14

84079 Bruckberg

GERMANY

Telephone: +49 8765 82-0

Fax: +49 8765 82-200

Email: info@efaflex.com

Internet: www.efaflex.com