

961

962

Technical product description
High-speed spiral door classic
High-speed turbo door



For internal use only

This technical product description
applies to the following door system types:

EFA-SST@-L Classic

EFA-SST@-S Classic

EFA-SST@-ÜS Classic

EFA-STT@-L

EFA-STT@-S

EFA-STT@-ÜS

EFAFLEX Tor- und Sicherheitssysteme GmbH & Co. KG

Fliederstraße 14

84079 Bruckberg

GERMANY

Telephone: +49 8765 82-0

Fax: +49 8765 82-200

Email: info@efaflex.com

Internet: www.efaflex.com

Translation of the original

Version 00-EN

26.07.2017

© EFAFLEX Tor- und Sicherheitssysteme GmbH & Co. KG

Door system designations

Official designation of the door system	Spiral type	Designation of the door system in this product description
EFA-SST®-L Classic	Round spiral	237 R
	Oval spiral	237 O
	Low lintel	243 N
EFA-SST®-S Classic	Round spiral	238 R
	Oval spiral	238 O
	Low lintel	236 N
EFA-SST®-ÜS Classic	Round spiral	235 R
	Oval spiral	235 O
EFA-STT®-L	Round spiral	231 R
	Low lintel	272 N
EFA-STT®-S	Round spiral	232 R
EFA-STT®-ÜS	Round spiral	247 R

Table of contents

1	Short description.....	5
2	Technical properties.....	6
3	Construction of the high-speed spiral door.....	16
4	Door safety.....	34
5	Equipment.....	37
6	Packaging units.....	38

1 Short description

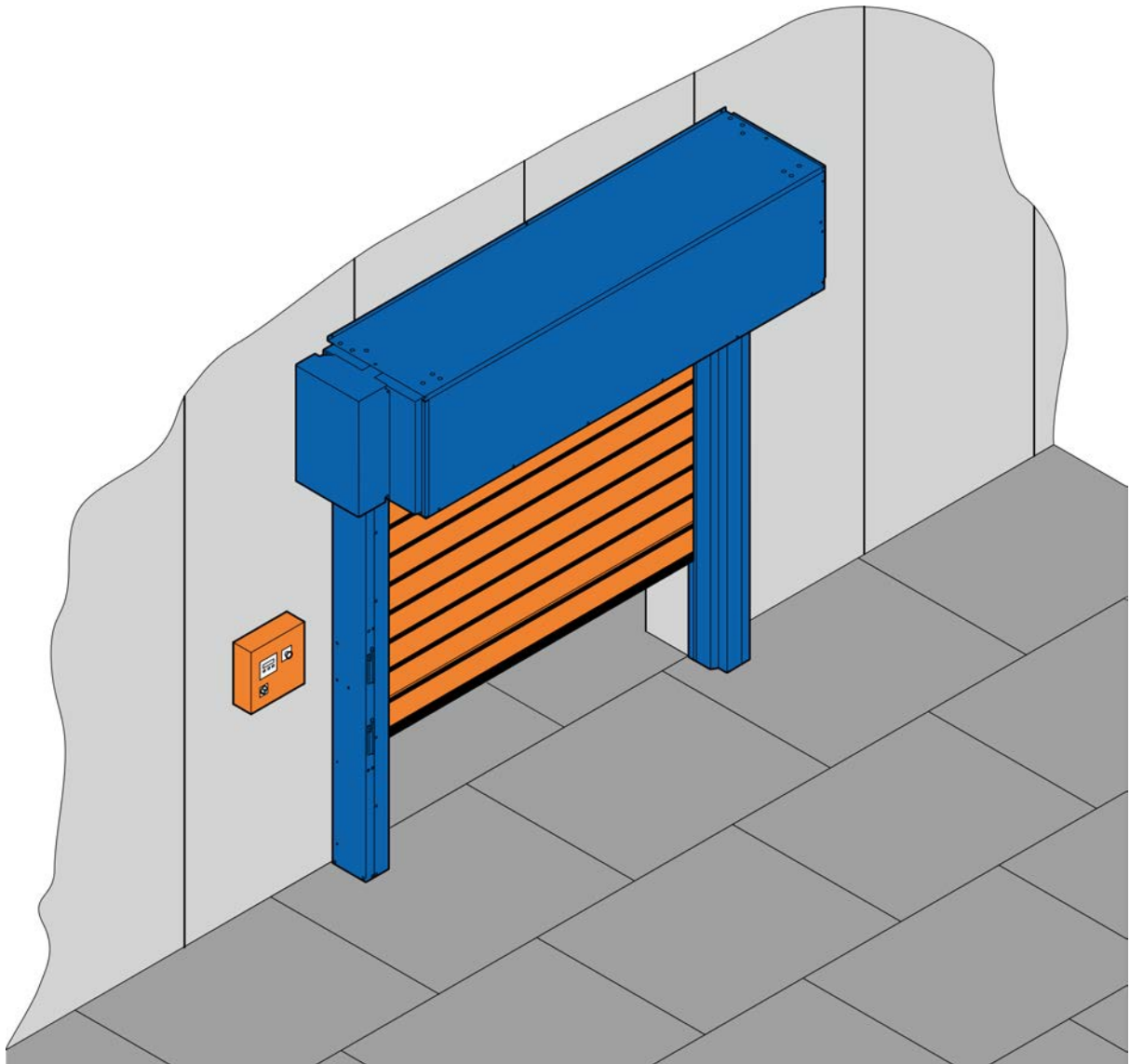

Fig. 1: High-speed spiral door

S series high-speed spiral doors and high-speed turbo doors are door systems designed for industrial and commercial purposes. The basic construction is based on tried and tested spiral door technology.

The door leaf for the EFA-SST® Classic is equipped with 20, 30 and 40 mm thick, double-walled, aluminium extrusion-press laths with a spacing of 151 mm.

The door leaf for the EFA-STT® is equipped with 30, 40 and 60 mm thick, aluminium extrusion-press profiles and a pressure-grouted, single-wall filling with a spacing of 225 mm.

2 Technical properties

Use

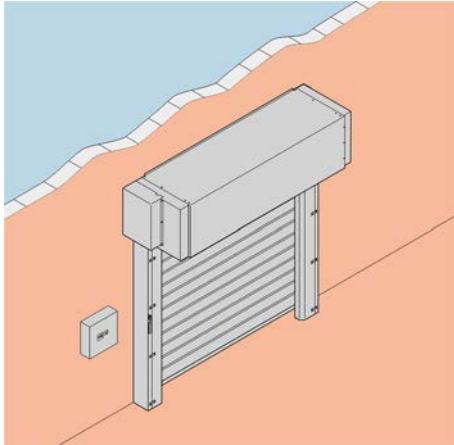

Fig. 2: Use

Use

- Industrial door
- Hall door
- Outdoor installation under a canopy provided by the owner (installation of the control unit: > +5 °C)

	Outdoor (-15 °C to +50 °C)
	Indoor (+5 °C to +50 °C)

Dimensions 231 R

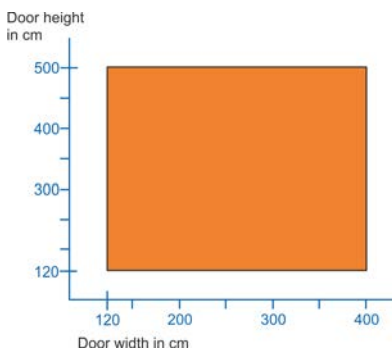

Fig. 3: Diagram of possible door system heights and door system widths

i It is not possible to use a door light grid if the height of the door system is lower than 1850 mm.

Door system heights and widths (inner clear height)

Door system type	Widths	Heights
231 R	1200 – 4000 mm	1200 – 5000 mm

Dimensions 232 R

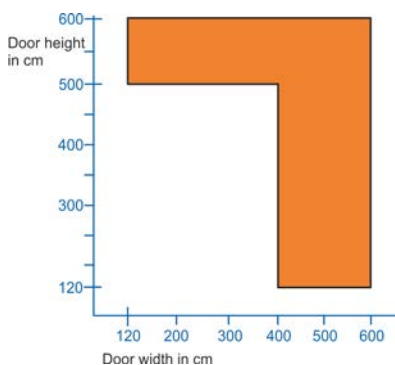

Fig. 4: Diagram of possible door system heights and door system widths

i It is not possible to use a door light grid if the height of the door system is lower than 1850 mm.

Door system heights and widths (inner clear height)

Door system type	Widths	Heights
232 R	1200 – 4000 mm	5000 – 6000 mm
	4001 – 6000 mm	1200 – 6000 mm

Dimensions 235 R

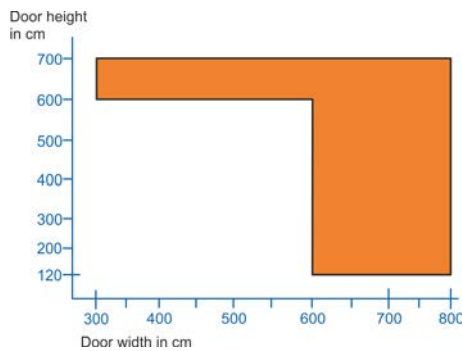

Fig. 5: Diagram of possible door system heights and door system widths



It is not possible to use a door light grid if the height of the door system is lower than 1850 mm.

Door system heights and widths (inner clear height)

Door system type	Widths	Heights
235 R	3000 – 6000 mm	6000 – 7000 mm
	6001 – 8000 mm	1200 – 7000 mm

Dimensions 235 O

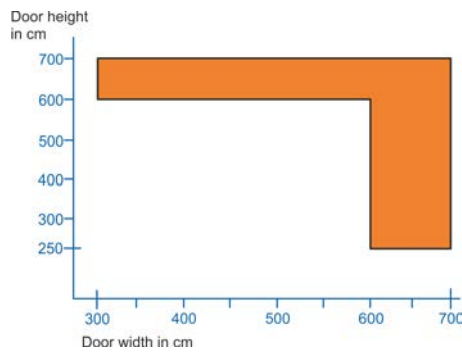

Fig. 6: Diagram of possible door system heights and door system widths

Door system heights and widths (inner clear height)

Door system type	Widths	Heights
235 O	3000 – 6000 mm	6000 – 7000 mm
	6001 – 7000 mm	2500 – 7000 mm

Dimensions 236 N

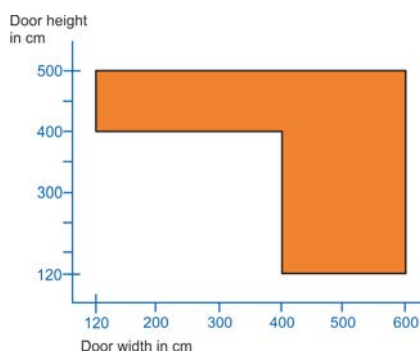

Fig. 7: Diagram of possible door system heights and door system widths



It is not possible to use a door light grid if the height of the door system is lower than 1850 mm.

Door system heights and widths (inner clear height)

Door system type	Widths	Heights
236 N	1200 – 4000 mm	4000 – 5000 mm
	4001 – 6000 mm	1200 – 5000 mm

Technical properties

Dimensions 237



Fig. 8: Diagram of possible door system heights and door system widths

There are two different structural designs of the side frames for door systems of type 237.

In door area “A”, the side frame depth of both side frames is 235 mm – 2 springs can be used on the left and on the right in this area.

In door area “B”, the side frame depth of both side frames is 285 mm – up to 3 springs can be used on the left and on the right in this area.



It is not possible to use a door light grid if the height of the door system is lower than 1850 mm.

Door system heights and widths (inner clear height)

Door system type	Widths	Heights
237 R; 237 O	1200 – 4000 mm	1200 – 5000 mm

Dimensions 238

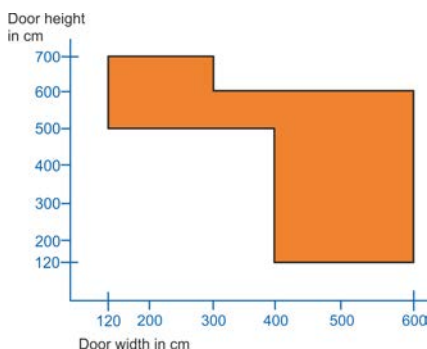

Fig. 9: Diagram of possible door system heights and door system widths



It is not possible to use a door light grid if the height of the door system is lower than 1850 mm.

Door system heights and widths (inner clear height)

Door system type	Widths	Heights
238 R; 238 O	1200 – 3000 mm	5000 – 7000 mm
	3001 – 4000 mm	5000 – 6000 mm
	4001 – 6000 mm	1200 – 6000 mm

Dimensions 243 N

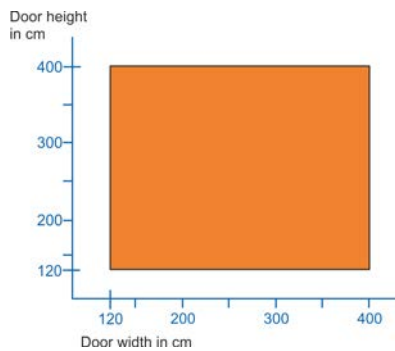

Fig. 10: Diagram of possible door system heights and door system widths



It is not possible to use a door light grid if the height of the door system is lower than 1850 mm.

Door system heights and widths (inner clear height)

Door system type	Widths	Heights
243 N	1200 – 4000 mm	1200 – 4000 mm

Dimensions 247 R

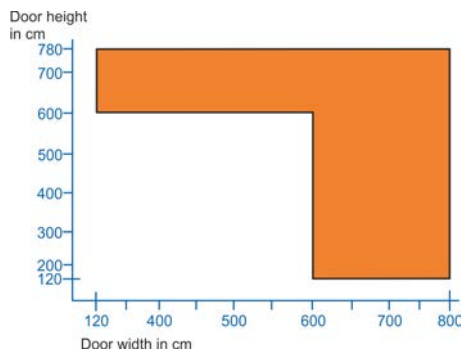

Fig. 11: Diagram of possible door system heights and door system widths



It is not possible to use a door light grid if the height of the door system is lower than 1850 mm.

Door system heights and widths (inner clear height)

Door system type	Widths	Heights
247 R	1200 – 6000 mm	6000 – 7800 mm
	6001 – 8000 mm	1200 – 7800 mm

Dimensions 272 N

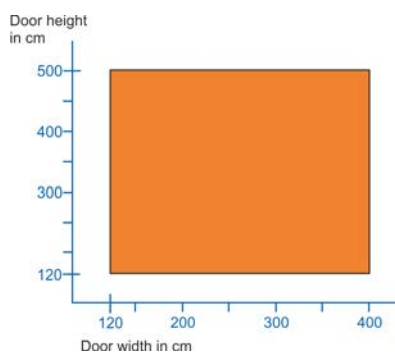

Fig. 12: Diagram of possible door system heights and door system widths



It is not possible to use a door light grid if the height of the door system is lower than 1850 mm.

Door system heights and widths (inner clear height)

Door system type	Widths	Heights
272 N	1200 – 4000 mm	1200 – 5000 mm

Technical properties

Speeds

Door system type	Average speed (max. speed)		
	Opening speed	Closing speed with door light grid	Closing speed with contact edge and light barrier
237 R, O	1.5 m/s (2.0 m/s)	1.0 m/s	0.75 m/s
243 N	1.0 m/s (1.5 m/s)	1.0 m/s	0.75 m/s
238 R, O	1.2 m/s (2.0 m/s)	1.0 m/s	0.6 m/s
236 N	1.2 m/s (1.5 m/s)	1.0 m/s	0.6 m/s
235 R, O	1.0 m/s (1.5 m/s)	1.0 m/s	0.6 m/s
231 R	2.5 m/s (3.0 m/s)	1.0 m/s	0.75 m/s
272 N	1.5 m/s (1.8 m/s)	1.0 m/s	0.75 m/s
232 R	2.2 m/s (2.8 m/s)	0.6 m/s	0.6 m/s
247 R	(1.8 m/s) (2.0 m/s)	0.6 m/s	0.6 m/s

Speeds dependent on the height of the door system

Performance properties as per DIN EN 13241-1

Door system type	Indication	Door system width/size, other information	Value	
			237	243
237 R 237 O 243 N	Resistance to wind load as per DIN EN 12424	$1200 \text{ mm} \leq B \leq 3100 \text{ mm}$	Class 4	Class 4
		$3100 \text{ mm} < B \leq 3500 \text{ mm}$	Class 3	Class 3
		$3500 \text{ mm} < B \leq 4000 \text{ mm}$	Class 2	Class 2
	Resistance to water penetration as per DIN EN 12425	-	Class 0	npd
	Air permeability as per DIN EN 12426	-	Class 2	npd
	Airborne sound insulation as per EN ISO 717-1	for standard aluminium lath	Rw = 23 dB	Rw = 23 dB
	Thermal insulation as per DIN EN 12428	for standard aluminium lath for $4000 \times 5000 \text{ mm}$	U = 5.80 W/m ² K	U = 5.80 W/m ² K

npd = no performance determined

Door system type	Indication	Door system width/size, other information	Value	
			238	236
238 R 238 O 236 N	Resistance to wind load as per DIN EN 12424	$1200 \text{ mm} \leq B \leq 6000 \text{ mm}$	Class 4	Class 4
		Resistance to water penetration as per DIN EN 12425	-	Class 0
	Air permeability as per DIN EN 12426	-	Class 2	npd
	Airborne sound insulation as per EN ISO 717-1	for standard aluminium lath	Rw = 25 dB	Rw = 25 dB
	Thermal insulation as per DIN EN 12428	for $6000 \times 6000 \text{ mm}$	U = 5.60 W/m ² K	U = 5.60 W/m ² K

npd = no performance determined

Technical properties

Door system type	Indication	Door system width/size, other information	Value
235 R 235 O	Resistance to wind load as per DIN EN 12424	$1200 \text{ mm} \leq B \leq 6000 \text{ mm}$	Class 4
		$6000 \text{ mm} < B \leq 7000 \text{ mm}$	Class 3
		$7000 \text{ mm} < B \leq 8000 \text{ mm}$	Class 2
	Resistance to water penetration as per DIN EN 12425	-	Class 0
	Air permeability as per DIN EN 12426	-	Class 2
	Airborne sound insulation as per EN ISO 717-1	for standard aluminium lath	Rw = 25 dB
Thermal insulation as per DIN EN 12428	for standard aluminium lath for $8000 \times 7000 \text{ mm}$	U = 5.60 W/m ² K	

Door system type	Indication	Door system width/size, other information	Value	
			231	272
231 R 272 N	Resistance to wind load as per DIN EN 12424	$1200 \text{ mm} \leq B \leq 3500 \text{ mm}$	Class 4	Class 4
		$3500 \text{ mm} < B \leq 4000 \text{ mm}$	Class 3	Class 3
	Resistance to water penetration as per DIN EN 12425	-	Class 0	npd
	Air permeability as per DIN EN 12426	-	Class 2	npd
	Airborne sound insulation as per EN ISO 717-1	-	Rw = 20 dB	Rw = 20 dB
Thermal insulation as per DIN EN 12428	for $4000 \times 5000 \text{ mm}$	U = 6.50 W/m ² K	U = 6.50 W/m ² K	

npd = no performance determined

Technical properties

Door system type	Indication	Door system width/size, other information	Value
232 R	Resistance to wind load as per DIN EN 12424	1200 mm ≤ B ≤ 4600 mm	Class 4
		4600 mm < B ≤ 5200 mm	Class 3
		5200 mm < B ≤ 6000 mm	Class 2
	Resistance to water penetration as per DIN EN 12425	-	Class 0
	Air permeability as per DIN EN 12426	-	Class 2
	Airborne sound insulation as per EN ISO 717-1	-	Rw = 20 dB
Thermal insulation as per DIN EN 12428	for 6000 × 6000 mm	U = 6.37 W/m²K	

Door system type	Indication	Door system width/size, other information	Value
247 R	Resistance to wind load as per DIN EN 12424	1200 mm ≤ B ≤ 6000 mm	Class 4
		6000 mm < B ≤ 7000 mm	Class 3
		7000 mm < B ≤ 8000 mm	Class 2
	Resistance to water penetration as per DIN EN 12425	-	Class 0
	Air permeability as per DIN EN 12426	-	Class 2
	Airborne sound insulation as per EN ISO 717-1	-	Rw = 20 dB
Thermal insulation as per DIN EN 12428	for 8000 × 7800 mm	U = 6.28 W/m²K	

Fire performance as per DIN 4102

Indication	Value
Material class	B2 normally inflammable

Technical properties

Applied ordinance, safety standards and directives

The following ordinance, standards and directives were applied for planning, engineering and production:

Ordinance

EUV 305/2011	Ordinance (EU) No. 305/2011 of the European Parliament and the Council of 9th March 2011 on the definition of harmonised conditions for the marketing of construction products and the withdrawal of Directive 89/106/EEC of the Council
--------------	--

Directives

2006/42/EC	DIRECTIVE 2006/42/EC OF THE EUROPEAN PARLIAMENT AND COUNCIL from 17th May 2006 on machines and for amendment of Directive 95/16/EC (new release)
2014/30/EU	DIRECTIVE 2014/30/EU OF THE EUROPEAN PARLIAMENT AND COUNCIL from 26th February 2014 for harmonization of the legal requirements of member states for electromagnet compatibility (new release)

Standards

DIN EN 13241	Doors – Product standard, Performance properties
DIN EN ISO 13849-1	Safety of machinery – Safety-related parts of control systems – Part 1: General design principles
DIN EN ISO 13849-2	Safety of machinery – Safety-related parts of control systems – Part 2: Validation
DIN EN ISO 12100	Safety of machinery – General design principles – Risk assessment and risk reduction

Performance

Door system type (SST)	Load cycles per year	Life cycle
237 R; 237 O	250,000	10 years
238 R; 238 O		
235 R; 235 O		

Door system type (SST)	Load cycles per year	Life cycle
243 N	150,000	10 years
236N		

Door system type (STT)	Load cycles per year	Life cycle
231 R	200,000	10 years
232 R		
247 R		

Door system type (STT)	Load cycles per year	Life cycle
272 N	120,000	10 years

3 Construction of the high-speed spiral door

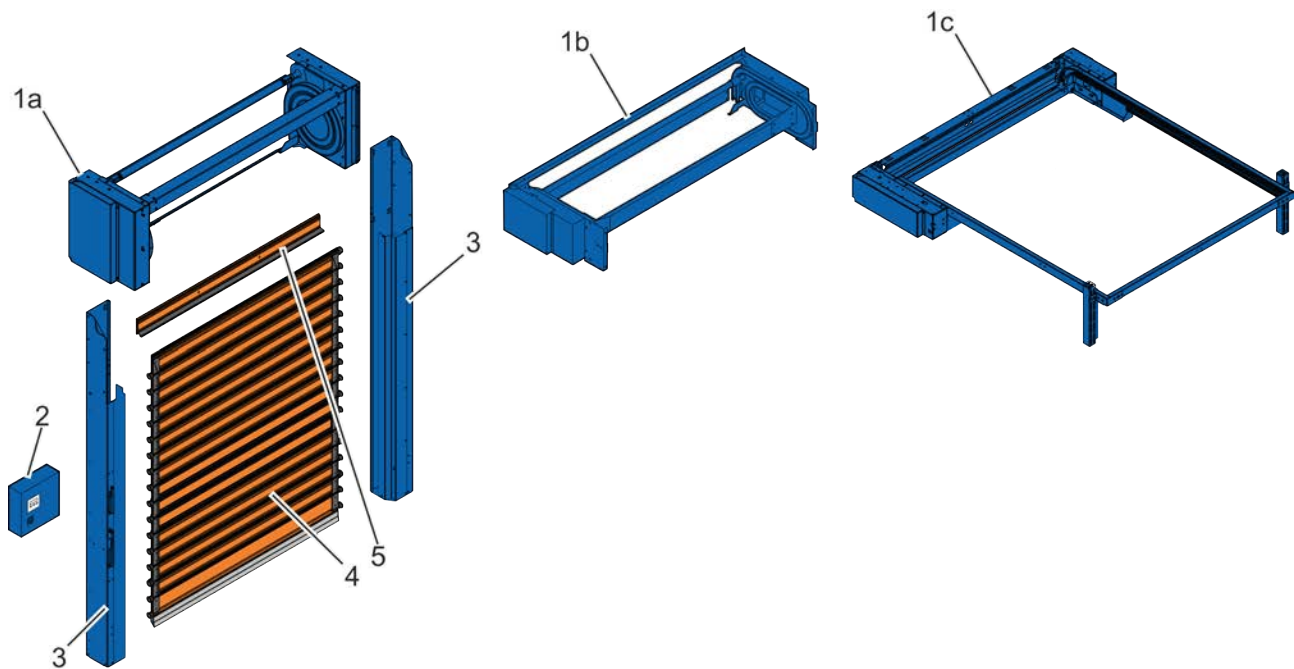

Fig. 13: Assemblies

1	Round spiral case (item 1a), oval (item 1b) or low (item 1c) with main support, spiral guide, engine, drive shaft, bearing, reinforcement profiles, cover (optional)	<ul style="list-style-type: none"> ↳ "Spiral case versions" on page 17 ↳ "Overview of drives", starting on page 30
2	Control	↳ "Overview of the controls", starting on page 31
3	Side frames with vertical door leaf guide, tooth belt for door leaf, weight counterbalance and door light grid	<ul style="list-style-type: none"> ↳ "Door leaf guide and side frame" on page 24 ↳ "Transmission of force" on page 20 ↳ "Counterbalance" on page 21 ↳ "Door light grid" on page 36
4	Door leaf	↳ "Door leaf" on page 25
	Laths	↳ "Overview of the laths", starting on page 25
	Safety edge	↳ "Safety edge and safety light barrier" on page 35
5	Horizontal seal	↳ "Seal" on page 29

Spiral case

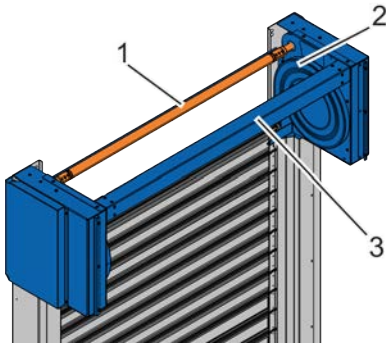

Fig. 14: Round spiral case

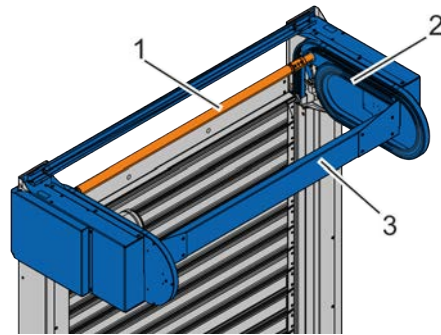

Fig. 15: Oval spiral case

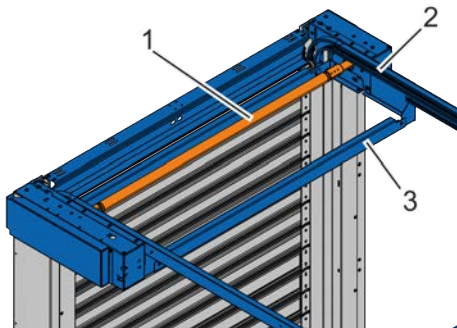

Fig. 16: Low spiral case

The spiral case is available in "round", "oval" and "low" versions.

The spiral case comprises:

- Synchronous shaft with bearing (item 1)
- bevelled, main supports with spiral guide (item 2) on both sides
- Sheet metal reinforcement profiles (item 3)

Construction of the high-speed spiral door

Spiral case cover (optional)

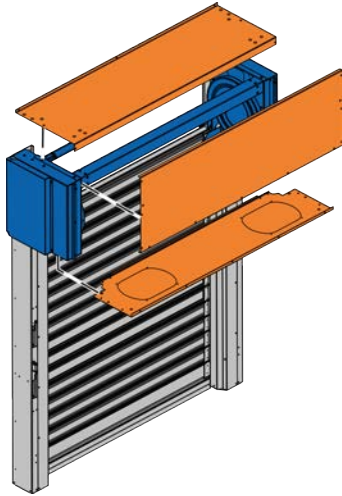

Fig. 17: Round spiral case cover

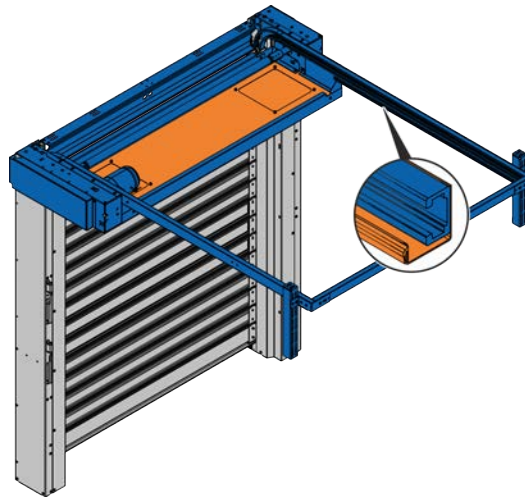

Fig. 18: Low lintel spiral case cover

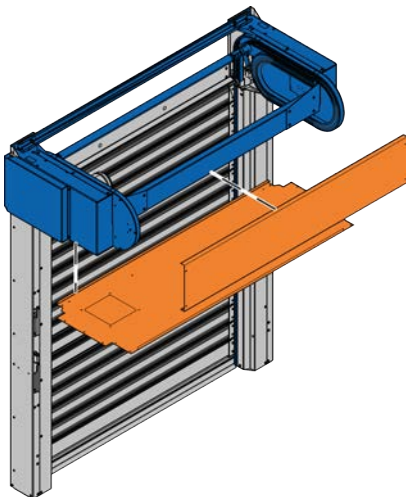

Fig. 19: Oval spiral case cover



The cover for the low lintel and the round spiral has two inspection openings.

The cover for the oval spiral has one inspection opening.

Door systems of type 235 and 247 do not have any inspection openings.

The spiral case can optionally be covered at the bottom, front and top. The covers can reduce the clear height.

Covers on the front and bottom are only possible in combination. The top cover is only possible if the front and bottom are also panelled. On door systems with an oval spiral, the cover on the top is not possible.

The sheet metal profiles are equipped with inspection openings, which can be opened, for maintenance purposes. The lath profiles can be easily pulled out of the guide and removed by hand.



The spiral case cover as finger protection is regulation for door systems with a height of less than 2500 mm or 2300 mm with low lintel.

Door system type	Sheet metal profile			Hinged side frame cover
	bottom + front	top	Restriction of clear height	
237 R	available	available	35 mm*	available
237 O	up to H = 3000 mm	-	35 mm	available

Construction of the high-speed spiral door

Door system type	Sheet metal profile			Hinged side frame cover
	bottom + front	top	Restriction of clear height	
243 N	available	-	none	available
238 R	available	available	35 mm	available
238 O	up to $B \leq 4500$ mm or up to $B = 4500$ mm and $H \leq 4000$ mm	-	55 mm	available
236 N	available	-	none	available
235 R	available	available	40 mm	•
235 O	-	-	-	•
231 R	available	available	35 mm*	available
272 N	available	-	none	available
232 R	available	available	35	available
247 R	available	available	50 mm	•

• Standard

- not available

* Restriction does not apply to $H \leq 3000$ mm (237) and $H \leq 2900$ mm (231)

Construction of the high-speed spiral door

Transmission of force

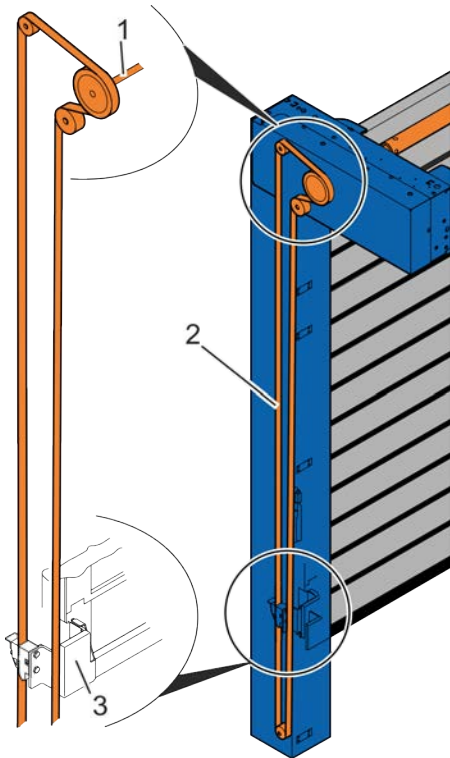

Fig. 20: Low lintel transmission of force

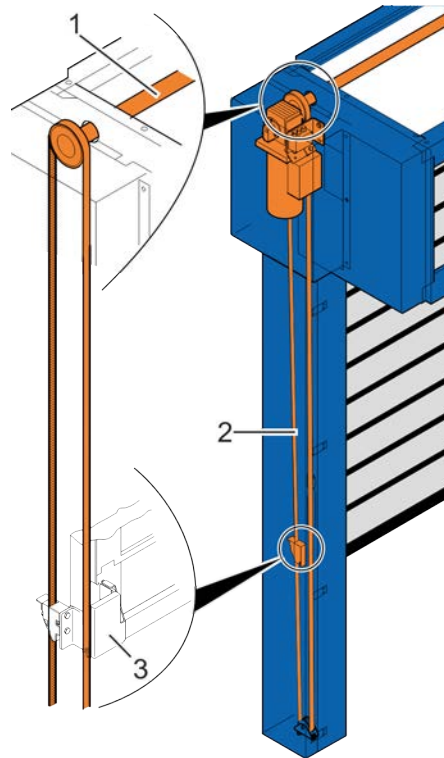

Fig. 21: Round and oval spiral transmission of force

The transmission of force from the drive to the door leaf is performed by the synchronous shaft (Fig. 21 and Fig. 20/1), the circumferential toothed belt (Fig. 21 and Fig. 20/2) and the door leaf mounts (Fig. 21 and Fig. 20/3). Unlike a chain, the toothed belt runs very quietly.

The door leaf mounts are situated on the right and left-hand sides of the door leaf and are screwed to the hinge chains and the lowest lath of the door leaf (bottom lath). The hinge chains on both sides of the door system connect the bottom lath to the other laths. When the door leaf moves, the force is only applied to the bottom lath. All the other laths are fastened to the hinge chain and are moved at the same time without the effect of force.

Counterbalance

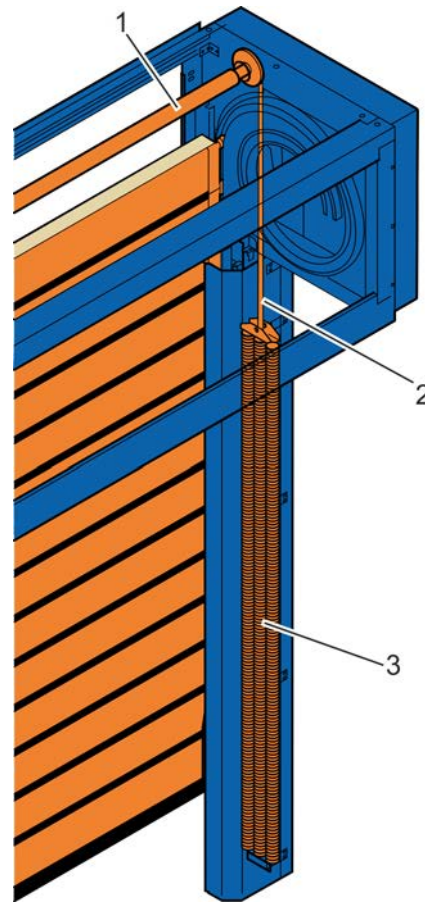

Fig. 22: Counterbalance

The door leaf counterbalance is a back pull mechanism: Tension springs (Fig. 22/3) are installed in the side frames. The tension springs are connected to the synchronous shaft (Fig. 22/1) by heavy-duty belts (Fig. 22/2). The tension springs are tensioned when the door system is closed and relaxed when the door system is open.

This way the door system can also be opened by hand (without electrical power) in case of emergencies. In normal mode the motor is assisted by the force of the tension springs.

The spring tension is calculated for each individual order.

Construction of the high-speed spiral door

Emergency lever



Fig. 23: Emergency lever on the side frame (left side) and on the console (right side)

The emergency lever is situated on the side frame or optionally on a separate console. When the lever is pulled, the drive brake is enabled and the door system is partially opened automatically by the tension springs of the counterbalance system. The door can be opened completely by pushing the door leaf upwards manually. The control unit is in EMERGENCY STOP status during this operation.

An optional emergency lever is also available in a lockable design.

Door locking mechanism (optional)

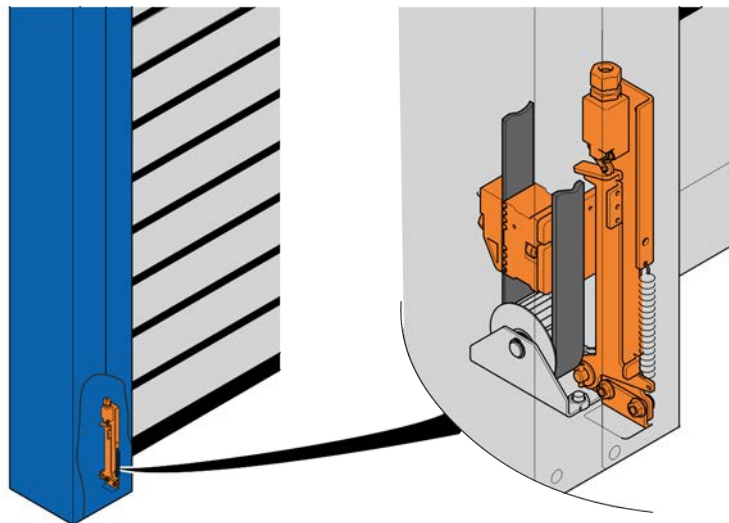
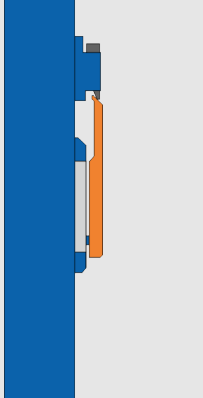
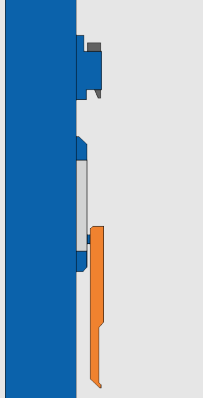
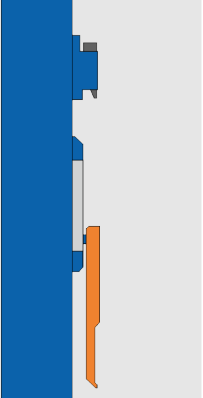
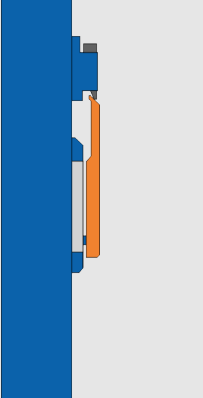
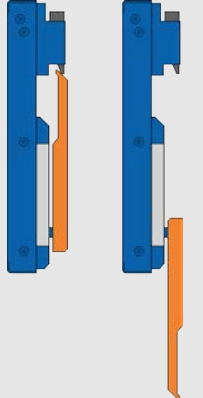

Fig. 24: Door locking mechanism

The mechanical locking mechanism is installed in the vertical side frame on the motor side. The locking mechanism handle keeps the door leaf closed so that it is safe from break-ins. The door locking mechanism is operated using a lever which is fitted to the side frame or on an optional separate console.

Construction of the high-speed spiral door

The following versions are possible:

Standard version: Lever fitted to side frame		Optionally: Lever fitted to the side frame with reversed lever position		Optionally: Lever fitter to a separate console
Door leaf not locked	Door leaf locked	Door leaf not locked	Door leaf locked	
				
Lever position: Lever up	Lever position: Lever down	Lever position: Lever down	Lever position: Lever up	The lever position depends on laying of Bowden cable
Optional locking version			Optional locking version	Lever position up, optional locking version

Construction of the high-speed spiral door

Door leaf guide, side frame and optional pivoting side frame cover

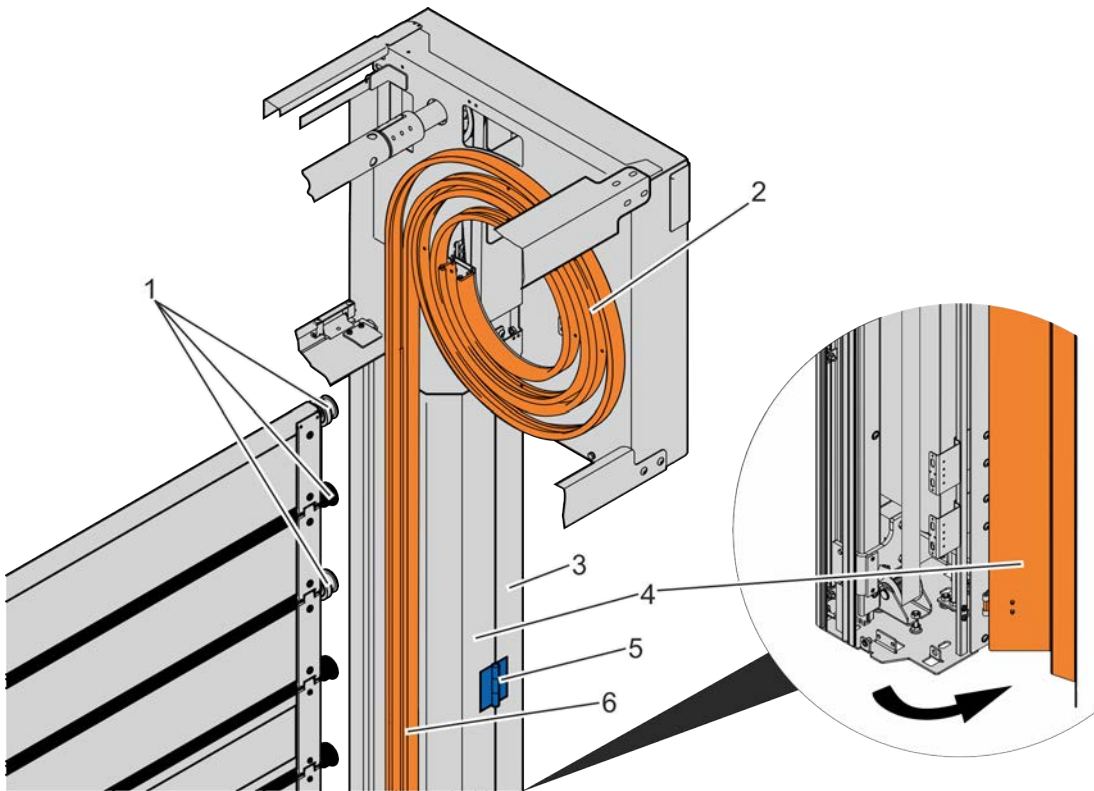

Fig. 25: Door leaf guide

The door leaf comprises laths which are connected by a hinge chain. Rollers (Fig. 25/1) are attached to the hinge chain. When the door system is opened and closed, the rollers are directed through the vertical (Fig. 25/6) and spiral-shaped (Fig. 25/2) door leaf guide. The rolling of the rollers in the door leaf guide only generates very low noise. The roller friction also makes for minimum wear on the rollers as no soiling is generated from abrasion. There is no wear on the door leaf itself. This gives the door system a long service life.

The vertical door leaf guides (Fig. 25/6) are made of sheet metal and aluminium profiles and are situated within the side frames (Fig. 25/3). Each side frame is made up of one main bevelled sheet metal profile and one bevelled sheet metal cover profile (Fig. 25/4). The sheet metal cover profiles are fastened with screws. Optionally they can also be supplied in a pivoting design with hinges (Fig. 25/5).

Construction of the high-speed spiral door

Door leaf

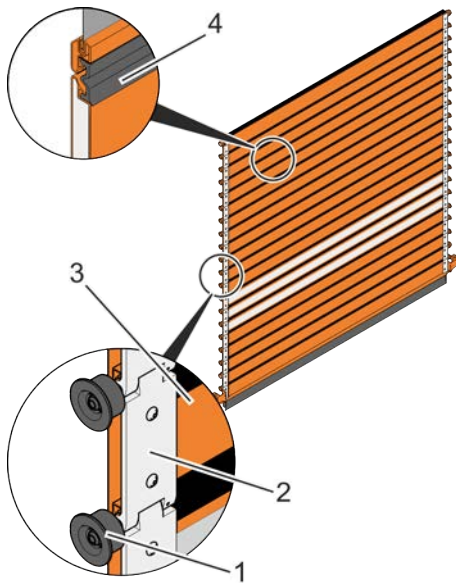

Fig. 26: Door leaf with 20 mm thick EFA-ALUX aluminium laths and a spacing of 151 mm (AST)

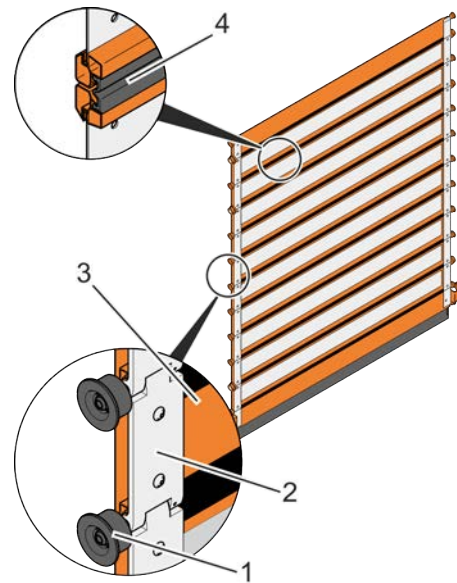

Fig. 27: Door leaf with 30 mm thick EFA-CLEAR sight laths and a spacing of 225 mm (LKZ)

The door leaf is assembled from laths (Fig. 26 and Fig. 27/3) which are held at the correct spacing by hinge chains (Fig. 26 and Fig. 27/2) attached at the sides. This spacing prevents contact between the laths. They are thus free from wear. The forces for opening and closing the door system are transmitted via hinges.

Ball-bearing mounted rollers (Fig. 26 and Fig. 27/1) keep the door leaf firmly in the guides in the horizontal direction. The laths are connected to each other by rubber hinges (Fig. 26 and Fig. 27/4).

The door leaf is equipped with 20 mm thick EFA-ALUX aluminium laths with a spacing of 151 mm (AST) or with a 30 mm thick door leaf with 30 mm thick EFA-CLEAR sight laths with a spacing of 225 mm (LKZ).

The 20 mm thick EFA-ALUX aluminium laths (AST) can optionally be equipped with EFA-CLEAR sight laths (SAN or polycarbonate filling) and EFA-VENT ventilation laths. The 30 mm thick EFA-CLEAR sight laths (LKZ) can also optionally be equipped with EFA-VENT ventilation laths as well as with a polycarbonate or a non-transparent SAN filling.

The tried and tested EFAFLEX door leaf design guarantees very good low noise operation.

Laths and door leaf thicknesses

Door system type	EFA-ALUX aluminium lath	EFA-CLEAR sight lath single-wall	EFA-VENT ventilation lath	Door leaf thickness
237 R	x	x	x	20 mm
237 O	x	x	x	

Construction of the high-speed spiral door

Door system type	EFA-ALUX aluminium lath	EFA-CLEAR sight lath single-wall	EFA-VENT ventilation lath	Door leaf thickness
243 N	x	x	x	30 mm
238 R	x	x	x	
238 O	x	x	x	
236 N	x	x	x	
235 R	x	x*	x*	40 mm
235 O	x	x*	x*	
231 R	-	x	x	30 mm
272 N	-	x	x	
232 R	-	x	x	40 mm
247 R	-	x	x	60 mm

* Sight glass screwed on

Calculation formula
viewing strip width (235)
EFA-CLEAR sight lath

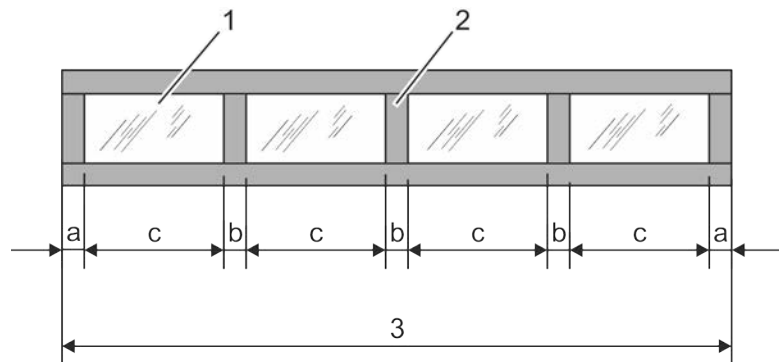

Fig. 28: Sketch of the calculation formula

- 1 Viewing strips, height approx. 82 mm
- 2 Middle bar
- 3 Light width
- a 90 mm
- b 100 mm
- c Dependent on the door width

$(B-575)/5$ for $B \leq 5000$ mm (5 viewing areas)

$(B-675)/6$ for $B > 5000$ mm (6 viewing areas)

Construction of the high-speed spiral door

EFA-ALUX aluminium lath

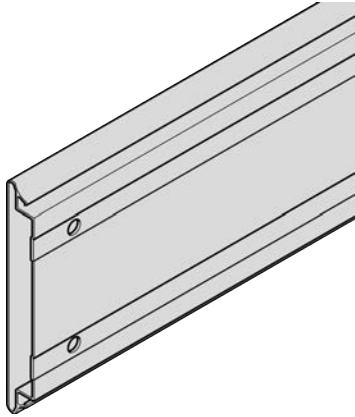

Fig. 29: EFA-ALUX aluminium lath

The EFA-ALUX aluminium lath comprises a double-walled anodised aluminium profile.

Dimensions of the lath	20/30/40 × 151 mm (AST)
Finish	E6/EV1 (natural anodised)
Optional	Powder coating for aluminium profiles Colours as per SAP

EFA-CLEAR sight lath, one-walled (option)

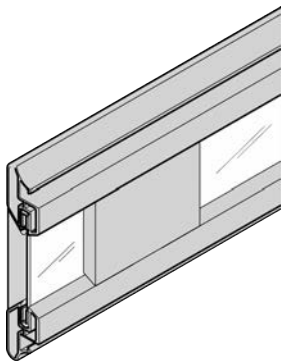

Fig. 30: EFA-CLEAR sight lath, (one-walled)

The EFA-CLEAR sight lath comprises transparent plastic panes pressed into the aluminium profiles.

Dimensions	20/30/40 × 151 mm (AST)
	30/40/60 × 225 (LKZ)
	Height of the viewing area:
	<ul style="list-style-type: none"> ■ approx. 82 mm (AST) ■ approx. 155 mm (LKZ) ■ approx. 136 mm (LKZ - 60 × 225)
Finish	E6/EV1 (natural anodised)
Glazing	SAN panes (transparent)
	SAN panes, (non-transparent, coloured aluminium gray)
	Hard polycarbonate panes (scratch resistant)
Optional	Varnish for the aluminium profiles Colours as per SAP

The number of sight laths is limited for AST.

Construction of the high-speed spiral door

EFA-VENT ventilation lath (optional)

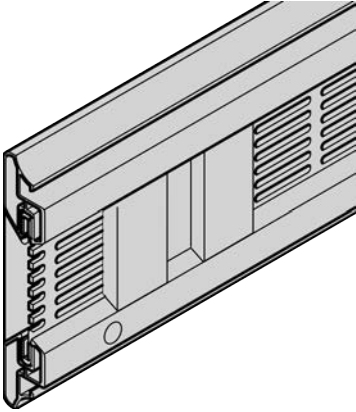

Fig. 31: EFA-VENT ventilation lath

The EFA-VENT ventilation lath comprises aluminium metal sheet with elongated holes (50 × 6 mm) which are pressed into the aluminium profiles.

Dimensions of the lath	20 × 151 mm (AST)
	30 × 225 mm (LKZ)
Finish	E6/EV1 (natural anodised)
Vent cross section	LA = ((B-0.180) × 0.041) × lath number (AST)
	LA = ((B-0.105) × 0.066) × lath number (LKZ) B = door system width in metres
Vent cross section (235)	B ≤ 5000 mm: LA = ((B-0.575) × 0.035) × laths
	B > 5000 mm: LA = ((B-0.675) × 0.035) × laths
Optional	Powder coating for aluminium profiles and ventilation sheets Colours as per SAP

The number of ventilation laths is limited for AST.

Seal

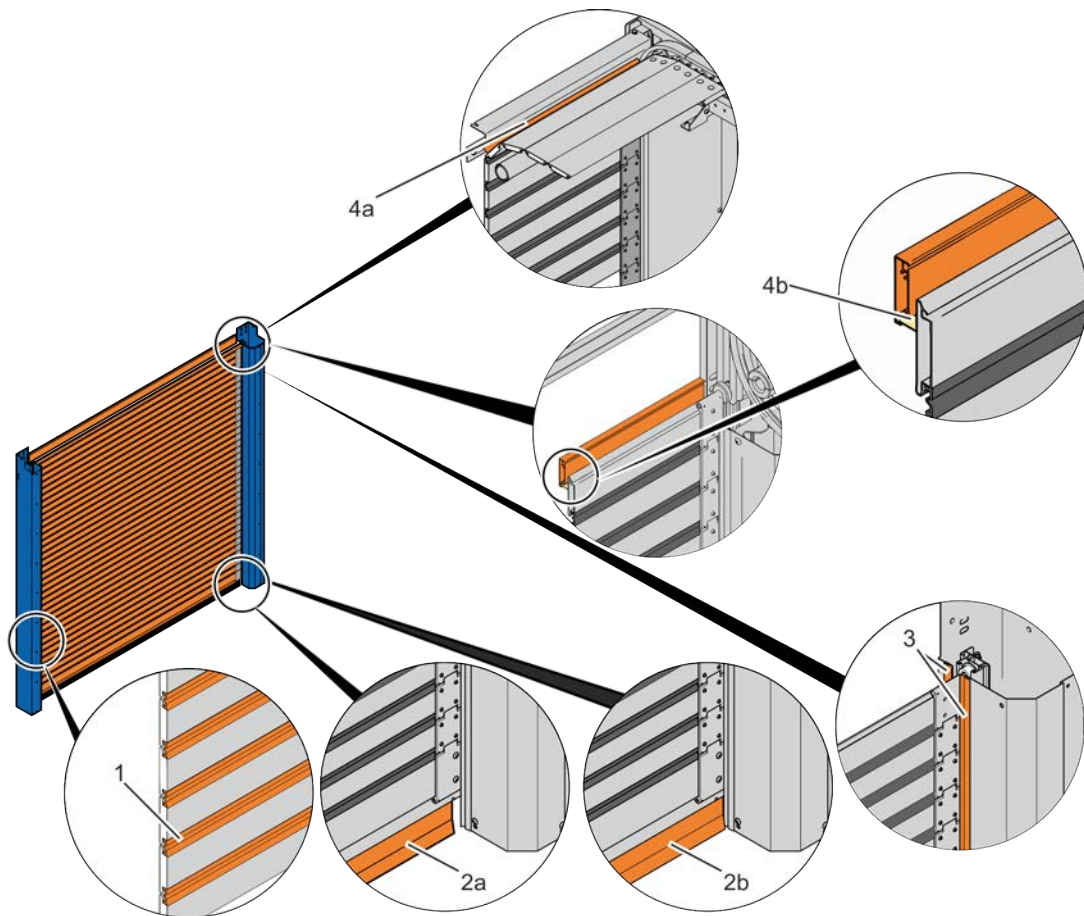

Fig. 32: Seal

The low-wear plastic door leaf seals (Fig. 32/3) provide the vertical sealing effect. The rubber profiles perform this function in the horizontal direction. With regard to door systems of types 237 R, 237 O, 243 N, 236 N and 272 N, the length of the rubber profile (Fig. 32/2) is B - 15 mm for structural reasons. For all other door system types of this product description, the rubber profile protrudes as far as the side frame on the left and on the right. The laths are sealed off by rubber hinges one below the other (Fig. 32/1).

A sealing profile, mounted between the consoles or on the lintel, seals off the top of the door system. The top of the door system is also sealed by additional profiles with a rubber lip, which are fastened to the uppermost 1 – 3 laths depending on the size and type of door system. If the door system is closed, the rubber lip seals off the sealing profile (Fig. 32/4a; 4b).

On door systems with a round or oval spiral, the sealing profile is made of aluminium and seals off on the rubber profile of the top lath. The height of the sealing profile is determined by the door leaf height, i.e. the door system height and lath spacing.

Construction of the high-speed spiral door

Drive

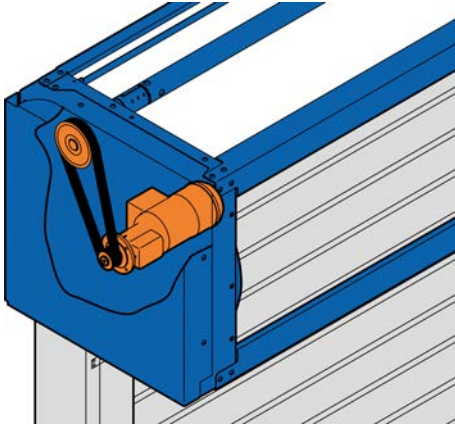

Fig. 33: Drive, door system types 237 R; 237 O; 243 N; 238 R; 238 O; 236 N; 231 R; 272 N; 232 R

237 R; 237 O; 243 N
238 R; 238 O; 236 N
231 R; 272 N
232 R

Drive type	Integrated into the spiral to save space; transmission of force via toothed belt (Spur gear, asynchronous AC motor)
Power classes	0.75 kW – 1.5 kW/50 Hz, 100 Hz
Protection type	IP54
Position detection	Absolute encoder. Thus no reference run is required.

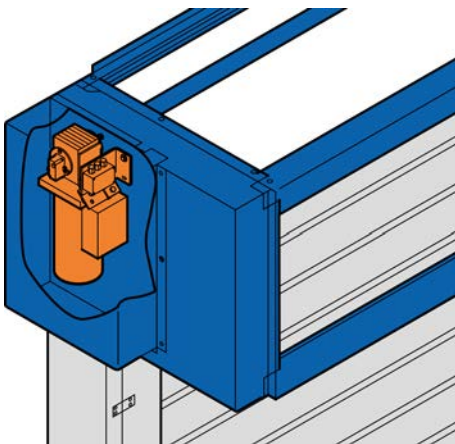

Fig. 34: Drive, door system types 235 R; 235 O; 247 R

235 R; 235 O
247 R

Drive type	Direct mount drive (Spur gear, asynchronous AC motor)
Power classes	2.2 kW/100 Hz
Protection type	IP54
Position detection	Absolute encoder, optional incremental encoder. Thus no reference run is required.

Construction of the high-speed spiral door

Controls

Door system type	EFA-TRONIC®	EFA-TRONIC® Professional
237 R	○	●
237 O	○	●
243 N	○	●
238 R	○	●
238 O	○	●
236 N	○	●
235 R	○	●
235 O	○	●
231 R	○	●
272 N	○	●
232 R	○	●
247 R	○	●

● Standard

○ Option

- not available for delivery

Construction of the high-speed spiral door

EFA-TRONIC® control

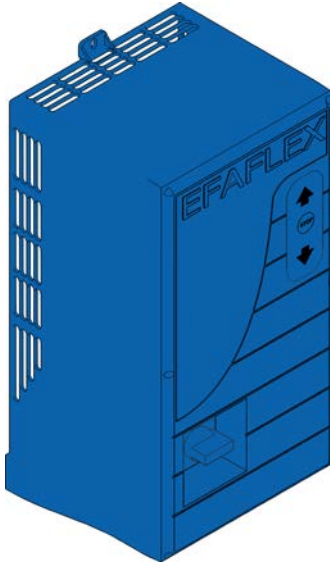

Fig. 35: EFA-TRONIC® control

Control	EFA-TRONIC® with frequency converter
Size (W × H × D)	210 × 400 (565)* × 200 mm (* incl. cable cover)
Housing	Polycarbonate housing
Protection type	IP65
Sight glass for display screen	Display of status messages and fault messages
Operating controls	Operating panel for operation and parametrisation of the door system Master switch
Supply voltage	L/N/PE 230 V ± 10 % or 3~L/N/PE 400 V ± 10 %
Frequency	50 – 60 Hz
Supply cable	Fuse protection of 16 A to be provided by the user (K characteristic)
With residual-current circuit breaker (RCCD) as necessary	300 mA as per DIN VDE 0100-530 (sensitive to universal current)

Construction of the high-speed spiral door

EFA-TRONIC® Professional

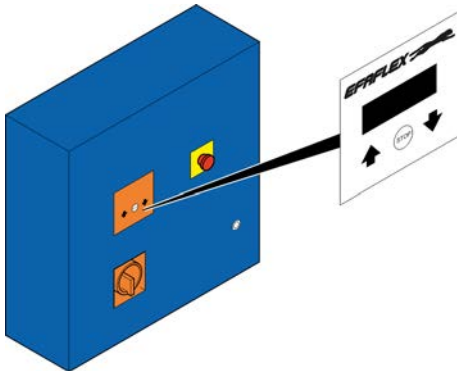

Fig. 36: EFA-TRONIC® Professional

Control	EFA-TRONIC® Professional with frequency converter
Size (W × H × D)	380 × 380 × 210 mm
Housing	Steel (V2A on request) Colour: RAL 7035
Protection type	IP65
Sight glass for display screen	Display of status messages and fault messages
Operating controls	Operating panel for operation and parametrisation of the door system Master switch
Supply voltage	L/N/PE 230 V ± 10 % or 3~L/N/PE 400 V ± 10 %
Frequency	50 – 60 Hz
Supply cable	Fuse protection of 16 A to be provided by the user (K characteristic)
With residual-current circuit breaker (RCCD) as necessary	300 mA as per DIN VDE 0100-530 (sensitive to universal current)

4 Door safety

Available door safety

Door system type	Safety edge and light barrier	Door light grid
237 R	●	○
237 O	●	○
243 N	●	○
236 N	●	○
231 R	●	○
272 N	●	○
247 R	○	●

Door system type	Door system width	Safety edge and light barrier	Door light grid
235	≤ 5000 mm	●	○
232	≤ 5000 mm	●	○
238	≤ 5000 mm	●	○
247 R	≤ 5000 mm	●	○

Door system type	Door system width	Safety edge and light barrier	Door light grid
235 R/O	> 5000 mm	○	●
232	> 5000 mm	○	●
238	> 5000 mm	○	●
247 R	> 5000 mm	○	●

- Standard
- Option
- not available for delivery



Simultaneous installation of a door light grid and light barrier is not possible.

The main closing edge is secured by a combination of a contact edge and a light barrier (C device plus D device). This achieves the minimum protection level as per EN 12453.

In addition, the owner and the manufacturer have to consult with each other in order to provide a safeguard for the approach area. This will be based on the owner's risk assessment.

Safety edge and safety light barrier

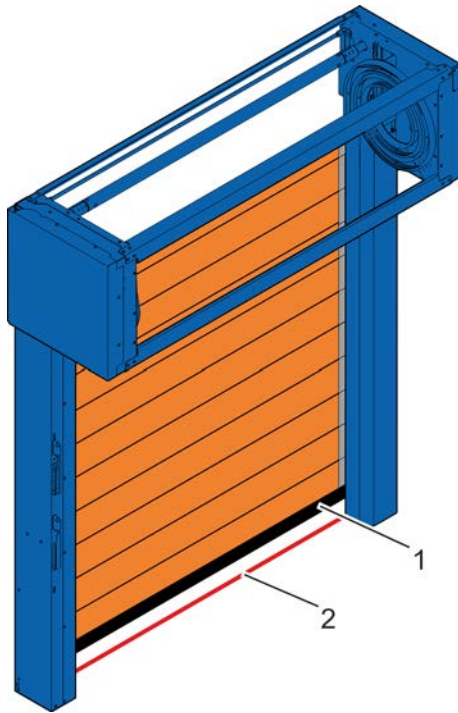

1	Safety for the closing edge	Safety edge
2	Safety light barrier (optional)	Unidirectional light barriers (IP67) max. 2 x

If the door system's safety edge comes into contact with an obstruction during the closing procedure, the door leaf stops, the door system opens completely and closes automatically again once the "keep-open" time has elapsed.

The safety light barriers which are installed in the side frames at the sides are offset from the door closing level. The height of the safety light barriers is variable.

Fig. 37: Safety edge and safety light barrier

Door light grid

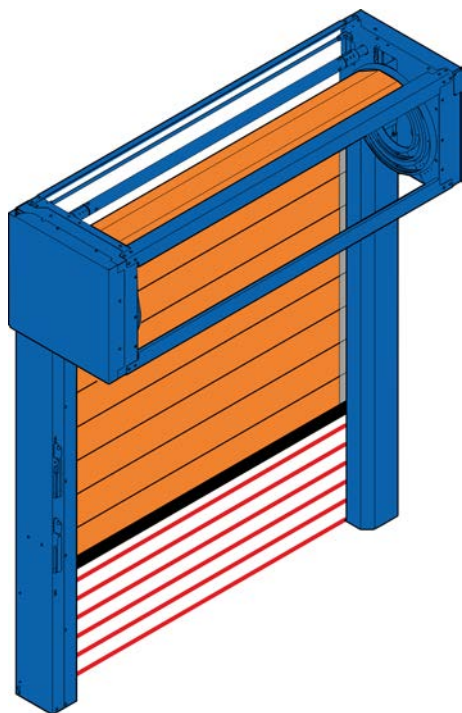

The door light grid which is installed in the side of the side frame monitors the closing level exactly, up to a height of 2.5 metres. The door light grid prevents the door system from closing when an obstruction is detected.

Fig. 38: Door light grid

5 Equipment

Standard equipment ¹

- Basic door construction, galvanised, 275 g/m²
- Pivoting side frame cover (235 R and 247 R)
- EFA-ALUX aluminium laths with a spacing of 151 mm (AST) or EFA-CLEAR sight laths with a spacing of 225 mm (LKZ)
- EFA-TRONIC® Professional in steel control cabinet
- Emergency operation device on side frame, not lockable
- Door light grid or safety edge with safety light barrier

¹ dependent on door system type and size

Optional equipment (special equipment subject to surcharge) ¹

- Basic door construction, galvanised (275 g/m²), with powder-coated finish in the colours as per SAP
- Basic door construction, stainless steel V2A 1.4301, corrosion resistant, polished grain 220
- EFA-CLEAR sight lath
- EFA-VENT ventilation lath
- Door leaf laths with painted finish as per RAL
- EFA-TRONIC®, EFA-TRONIC® Professional control
- Door light grid
- up to 2 safety light barriers
- Command devices: Push-buttons, pull switches, key switches etc.
- Command devices/safety: Radar detector, EFA-SCAN®, IR (infrared presence sensor)
- Spiral case covers
- Locking mechanism
- Locking mechanism which can be shut off
- Hinged side frame cover
- Frame extension on both sides
- "Door closed" limit switch, Schmersal roller lever switch type, Euchner CES safety limit switch, Pepperl and Fuchs NJ 15
- "Intermediate stop" limit switch, type Pepperl and Fuchs NJ 15
- "Door open" limit switch, Schmersal roller lever switch type

¹ dependent on configuration

Special constructions

Special constructions/special orders are design types which are not covered, either mechanically or electrically, by standard versions in the sales price lists or by a design from the technology variants table. They have to be requested specifically. Surcharges and extended delivery times are calculated for special designs in accordance with the actual expenditure.

6 Packaging units

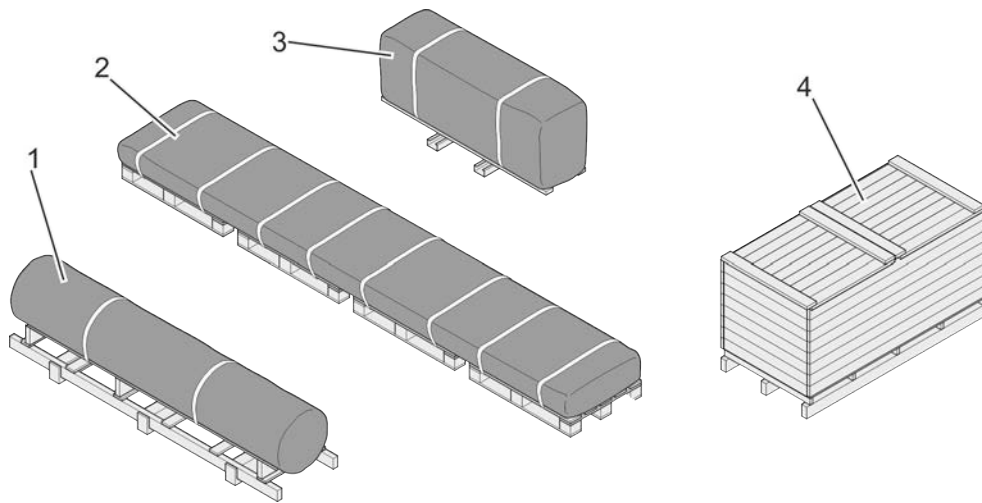

Fig. 39: Scope of delivery (left, standard transport unit), wooden crate (right, optionally for sea and fit-for-purpose* transport)



**Fit-for-purpose packaging is packaging which ensures that the packaged goods reach the recipient without damage, taking into account the shipping loads, shipping route, shipping duration and transportation load profile.*

Transport unit (example)

Transport unit 1: Door leaf package ("low lintel" version only)

Transport unit 2: Side frame sections with covers, control, accessories

Transport unit 3: Spiral case with door leaf, drive

Transport unit 4: Wooden crate (optional)

Number of transport units

The number of standard transport units depends on the selected number of door systems.

The door systems can also be delivered in a wooden crate. The number of wooden crates depends on the configuration of the door system types and the number of door systems.

The wood for the wooden crates optionally complies with the IPPC standard. For sea freight, the wooden crates are lined with film to protect them from moisture.

Packages which are fastened to pallets can be transported by fork lift under the following conditions:

- The fork lift must have the appropriate capacity for the weight of the packages.
- The package must be securely fastened to the pallet.
- The fork lift driver must be authorised to drive industrial trucks with a driver's seat or driver's station in accordance with the local regulations.



EFAFLEX Tor- und Sicherheitssysteme

GmbH & Co. KG

Fliederstraße 14

84079 Bruckberg

Germany

Telephone: +49 8765 82-0

Fax: +49 8765 82-200

Email: info@efaflex.com

Internet: www.efaflex.com